

# **Examination of Accident at Tokyo Electric Power Co., Inc.'s Fukushima Daiichi Nuclear Power Station and Proposal of Countermeasures (Draft)**

**This report has become final through to chapter 2. But subsequent chapters are still being checked to improve the quality of the translation.**

**It will become the final version after completing correction, such as unifying a term.**

**October 2011**

**Japan Nuclear Technology Institute**

**Examination Committee on Accident at Fukushima Daiichi Nuclear Power Station**

# Revision History

Date of Revision	Content of Revision	Note
<i>Month Day, 2011</i>	Newly created	

## Introduction

We, the Examination Committee on Accident at Fukushima Daiichi Nuclear Power Station, recognize that the accident at Tokyo Electric Power Co., Inc.'s Fukushima Daiichi Nuclear Power Station (hereafter called Fukushima Daiichi) caused by the Great East Japan Earthquake has shaken the foundation of the Japanese nuclear industry, and damaged the credibility of Japanese nuclear engineers. It has therefore made people deeply skeptical of the morale of the engineers who could not prevent the accident.

It is widely known that the direct cause of the accident was the tsunami which was far larger than had been anticipated when the power station was designed. The assumptions made at the time of designing the plant had been based on scientific data that were then the latest. However, it is true that the plant had insufficiently prepared for the worst case in which a tsunami far larger than anticipated might occur. As a result, the cores of Unit 1 to Unit 3 melted one after the other and radioactive materials were emitted into the environment to a degree as high as level 7 of the International Nuclear Event Scale (INES). We are very sorry that the accident caused a great deal of anxiety to the people living around the power stations that had understood and supported the operation of the power stations but were now forced to evacuate and live in unspeakable hardship.

The situation at Fukushima Daiichi has been stabilized for now thanks to the intensive work of the Self-Defense Forces, police, firefighters and local governments; desperate struggle of the power station staff and the employees of cooperative companies; the cooperation of each electric power company in neighboring monitoring; and various support and equipment provided by plant makers in Japan and overseas. Nevertheless, we still have to expect that it will be quite a long time until we can restore the surrounding environment.

Meanwhile, there is growing concern about the safety of nuclear power stations which were not directly affected by the Great East Japan Earthquake too, and stations located in populated areas. Therefore, the power stations that were stopped for periodical inspection or to investigate the causes of trouble or implement countermeasures still have not restarted even though the prescribed inspection or construction has finished. This is in part because the general public does not sufficiently understand the explanation of the situation given by the nation or electric companies. Therefore, the supply and demand balance of electricity in the summer was tight in many areas throughout the country, though this was narrowly overcome thanks to the efforts made by companies and individuals to save electricity, and the substitute use of thermal power stations.

A stable energy supply is the basic premise of our national economy and, in Japan where energy resources are scarce, the necessity of a stable power supply provided by nuclear power stations will not change at all in the future.

We think that the most overriding priority for the nuclear power industry is to calmly analyze the cause of the accident by returning to its origin, taking as many lessons as possible from the analysis. It must then use those lessons to improve the safety of Japanese nuclear power stations and, by doing so, make the efforts of the industry known to society.

In the case of Japanese nuclear power stations, emergency measures have been implemented twice at the initiative of supervising governmental bodies. However, some people living near nuclear power stations say that the correlation between the measures taken as the emergency measures and the cause of the accident or the passage of

events seen at Fukushima Daiichi is not clear. And they are not convinced that such measures can prevent an accident that would threaten the lives of neighboring people like that of the Fukushima Daiichi Nuclear Power Station did.

Under the circumstances mentioned above, detailed data on the plant behavior or analysis results were publicized by Tokyo Electric Power Co., Inc. during this period, which was almost half a year after the accident. In addition, the Japan Nuclear Technology Institute (JANTI) has established the "Accident Examination Committee" within the institute, convening many experts from inside and outside the nuclear power industry in addition to the experts of the JANTI as if collecting all of the power of the industry. It aims to clarify the view of the industry, analyze the sequence of events noticed at the accident site and the cause of the accident, extract lessons to be learned and, based on the lessons obtained put together measures which are likely to enhance the safety of nuclear power stations as the committee's proposal.

We, the Accident Examination Committee, asked the professionals of the "Nuclear Power Safety Professional Committee, Technology Analysis Subcommittee" within the Atomic Energy Society of Japan, which is the only academy to totally deal with nuclear power issues, to review our proposal. It will check if there were elements we overlooked or unreasonable points which were inconsistent with the measures to be taken.

The examination conducted this time is limited to the events which happened at the power station site during approximately the 5 initial days including the occurrence of the earthquake, the coming of the tsunami and the following core melting and hydrogen explosion. The purpose is to find a way to prevent core melting and the following emission of radioactive materials to the environment. We are of the opinion that if each company seriously takes up the measures described in this report, much stronger nuclear power stations can be built with multiple safety measures which can resist tsunami which are much bigger than the design grade, like the one that hit the Fukushima Daiichi Nuclear Power Station. However, we know that there are some points that have still not been clarified among the events that happened at Fukushima Daiichi Nuclear Power Station. Hence, we believe we need to review this report and add new findings whenever new information comes to light from now on. Furthermore, concerning the behavior of radioactive materials around power stations and the reaction of people concerned too, we need to analyze the lessons to be learned and study proposals for improvement.

The biggest lesson learned from this accident is that we must always review the safety measures imagining what will happen when there are events that exceed the conditions considered in designing or operating plants, and what measures are to be taken to ease the impact of such events. And we believe that the first step in restoring the credibility of nuclear power stations or of engineers working for nuclear power, i.e., the credibility lost in this accident, is to seriously continue to implement such measures and make the situation known not only to professionals but also to the general public.

We would greatly appreciate any opinions or comments you may have on this report.

October 2011

Examination Committee on Accident at Fukushima Daiichi Nuclear Power Station  
Chief Examiner, Takashi Dodo

## Members of the Examination Committee

### Deliberation Members of the Examination Committee on Accident at Fukushima Daiichi Nuclear Power Station

(Title omitted, position at the time of deliberation)

Chief examiner	Japan Nuclear Technology Institute, Executive Director	Takashi Dodo
	Hokkaido Electric Power Co., Inc., Nuclear Power Division Nuclear Fuel Control Office, Nuclear Power Technology Group Leader	Tomohiro Kodaira
	Tohoku Electric Power Co., Inc., Thermal Nuclear Power Headquarters Nuclear Power Division (Nuclear Power Technology), Section Manager	Tsunehiro Tada
	Chubu Electric Power Co., Inc., Nuclear PowerHeadquarters, Nuclear Powder Division Safety Technology Group Manager	Kouhiro Takeyama
	Hokuriku Electric Power Co., Inc., Nuclear Power Headquarters, Nuclear Powder Division Vice Manager (in charge of Technology and Quality Assurance)	Toshihiko Takahashi
	Kansai Electric Power Co., Inc., Nuclear Power Business Headquarters Nuclear Power Technology Division Manager	Hirohiko Yoshida
	Chugoku Electric Power Co., Inc., Electric Power Supply Business Headquarters (in charge of Nuclear Power Construction Electric Design) Manager	Yuichi Ida
	Shikoku Electric Power Co., Inc., Nuclear Power Headquarters Nuclear Power Division, Operation Group Leader	Masahiko Sato
	Kyushu Electric Power Co., Inc. Nuclear Power Generation Headquarters, Safety Technology Group Manager	Kazuaki Umada
	Japan Atomic Power Co., Inc., Power Generation Management Office Technology, Safety Group Manager	Satoru Fukuyama
	Japan Nuclear Fuel Limited, Safety Technology Office Safety Technology Division, Safety Technology Group	Tadashi Makihara
	Electric Power Development Co., Ltd. Nuclear Power Business Headquarters, Nuclear Power Construction Division, Assistant Manager	Sadayuki Kuramoto
	Toshiba Corporation Nuclear Power Fukushima Restoration Technology Division Manager	Mamoru Hatazawa
	Hitachi-GE Nuclear Energy, Ltd. Engineering Manager	Kumiaki Moriya
	Mitsubishi Heavy Industries Co., Ltd. Nuclear Power Business Headquarters, Safety Enhancement Measures Promotion Office, Office Manager	Yoshihiko Kato

# Report Study Members of the Examination Committee on Accident at Fukushima Daiichi Nuclear Power Station

(Title omitted, position at the time of deliberation)

Hokkaido Electric Power Co., Inc.	
Nuclear Power Division, Nuclear Power Facility Group	Katsumi Dazai
Nuclear Power Division, Nuclear Fuel Control Office, Nuclear Power Technology Group	Shinichiro Yasui
Tohoku Electric Power Co., Inc.	
Thermal Nuclear Power Headquarters, Nuclear Power Division (in charge of Safety Enhancement) Section Manager	Kouji Tadakuma
Thermal Nuclear Power Headquarters, Nuclear Power Division (Nuclear Power Technology) Vice Manager	Daisuke Sato
Thermal Nuclear Power Headquarters, Nuclear Power Division (Nuclear Power Technology)	Jun Takaishi
Chubu Electric Power Co., Ltd.	
Nuclear Power Headquarters, Nuclear Power Division, Operation Group, Section Manager	Tetsuya Watanabe
Nuclear Power Headquarters, Nuclear Power Division, Safety Technology Group, Section Manager	Kazuyuki Matsumoto
Nuclear Power Headquarters, Nuclear Power Division, Safety Technology Group	Akihiro Urano
Hokuriku Electric Power Co., Inc.	
Nuclear Power Headquarters, Nuclear Power Division, Nuclear Fuel Technology Team	Seishi Arakawa
Nuclear Power Headquarters, Nuclear Power Division, Nuclear Power Facility Management Team	Junichi Nishii
Nuclear Power Headquarters, Nuclear Power Division, Nuclear Power Generation Operation Team	Akira Ohbata
Kansai Electric Power Co., Inc.	
Nuclear Power Business Headquarters, Plant Maintenance Technology Group Manager	Toshihiko Tanaka
Nuclear Power Business Headquarters Manager	Kensuke Yoshihara
Chugoku Electric Power Co., Inc.	
Electric Power Supply Business Headquarters (in charge of Nuclear Power Construction Electricity Design) Sub Manager	Takatsugu Takatori
Electric Power Supply Business Headquarters (in charge of Nuclear Power Construction Safety) Sub Manager	Takeo Makino
Shikoku Electric Power Co., Inc.	
Nuclear Power Headquarters, Nuclear Power Division, Operation Group Sub Leader	Daisuke Mizobuchi
Kyushu Electric Power Co., Inc.	
Nuclear Power Generation Headquarters, Power Generation Management Group	Tsuyoshi Muto
Japan Atomic Power Co., Inc.	
Power Generation Management Office, Plant Management Group, Sub Manager	Masashi Nachi
Power Generation Management Office, Technology, Safety Group Chief	Masaru Yamanaka
Japan Nuclear Fuel Limited	
Safety Technology Office, Safety Technology Division, Safety Technology Group	Tadashi Makihara
Electric Power Development Co., Ltd.	
Nuclear Power Business Headquarters, Nuclear Power Construction Division, Facility Technology Group	Kouzou Miyao

Toshiba Corporation Power Systems Company, Nuclear Power System Design Division	Hirohide Oikawa
Hitachi-GE Nuclear Energy, Ltd. Nuclear Power Planning Division, Nuclear Reactor Planning Group, Chief Engineer	Kohei Hisamochi
Mitsubishi Heavy Industries Co., Ltd. Nuclear Reactor Safety Technology Division Manager	Shigemitsu Umesawa
Nuclear Reactor Safety Technology Division, Safety Technology Control Group Manager	Hisanaga Takahashi
Nuclear Reactor Safety Technology Division, Safety Technology Control Group	Mitsuhiro Kano
Japan Nuclear Technology Institute Director, Operating Experience Analysis Division Manager	Masuhiko Nakano
Observer Tokyo Electric Power Co., Inc., Nuclear Power Operation Management Division Manager	Takeshi Takahashi
Federation of Electric Power Companies of Japan, Nuclear Power Division Sub Manager	Tai Furuta

# **Report Review Team of the Examination Committee on Accident at Fukushima Daiichi Nuclear Power Station**

## **(Japan Nuclear Technology Institute)**

### **Board Members**

Director, General Affairs Division Manager	Akio Fukuda
Director, Safety Culture Division Manager	Etsuji Obu
Director, Codes and Standards Division Manager	Hiroyuki Ito
Consultant	Tamihei Nakamura Hiroaki Kawashima
Planning Office	Nobuyuki Kitamura Toshiki Nagasawa
General Affairs Division	Nobuyuki Onishi
Operating Experience Analysis Division	Ichiro Murakami Tomoyuki Yamazaki Kazuki Takada

## Abbreviations

ADS	Automatic Depressurization System
AM	Accident Management
AOvalve	Air Operated Valve
APD	Alarm Pocket Dosimeter
ASW	Auxiliary Sea Water System
BAF	Bottom of Active Fuel
BWR	Boiling Water Reactor
CCS	Containment Cooling System
CRD	Control Rod Drive
CS	Core Spray system
CST	Condensate Storage Tank
CWP	Circulating Water Pump
D/D FP	Diesel Driven Fire Pump
DG	Diesel Generator
D/W	Drywell
DWC	Drywell Cooling System
ECCS	Emergency Core Cooling System
EECW	Emergency Equipment Cooling Water system
FCS	Flammability Control System
FP	Fire Protection system
FPC	Fuel Pool Cooling and Filtering system
HPCI	High Pressure Coolant Injection System
HPCS	High Pressure Core Spray System
HPCW	HPCS Closed Cooling Sea Water System
IA	Instrument Air-System
IC	Isolation Condenser
ITV	Industrial Television
M/C	Metal-Clad Switch Gear
MCC	Motor Control Center
MCR	Main Control Room
MOvalve	Motor Operated Valve
MP	Monitoring Post
MSIV	Main Steam Isolation Valve
MUWC	Makeup Water System (Condensated)
MUWP	Makeup Water system (Purified)
O.P.	Onahama Pile
P/C	Power Center
PCIS	Primary Containment Isolation System
PCV	Primary Containment Vessel
PSA	Probabilistic Safety Analysis
PWR	Pressurized Water Reactor
R/B	Reactor Building
RCIC	Reactor Core Isolation Cooling System
RCW	Reactor Building Closed Cooling Water System
RHR	Residual Heat Removal System
RHRC	RHR Cooling Water System

RHRS	RHR Sea Water System
RPV	Reactor Pressure Vessel
RSW	Reactor Building Closed Cooling Sea Water System
S/C	Suppression Chamber
S/P	Suppression Pool
SA	Severe Accident
SBO	Station Black Out
SFP	Spent Fuel Pit (Cooling System)
SGTS	Stand-By Gas Treatment System
SHC	Shutdown Cooling System
SLC	Stand-by Liquid Control
SRV	Safety Relief Valve
T/B	Turbine Building
TAF	Top of Active Fuel
TSW	Turbine Building Closed Cooling Water System
UHS	Ultimate Heat Sink

## Glossary

Accident Management	(Measures against severe accidents) AM
Measures which are taken by effectively utilizing the safety allowance and the expected functions of the safety design in the existing design, other functions than the duly expected functions and devices which have been newly set up for such accidents in order to prevent a beyond design-basis accident which could lead to major core damage from expanding to a severe accident or to mitigate its impact in the event that the accident has developed to a severe accident.	
Air operated valve	AO valve
Valves which operate with compressed air	
Alarm Pocket Dosimeter	APD
A personal radiation monitor with an alarm using a semiconducting detector. It can record the name and time of the operation the carrier is engaged in.	
Alternative containment vessel spray	
It refers to the spray function for the containment vessel, effectively utilizing the existing condensate water makeup system and the water source and pumps of the fire service's water system.	
Alternative control rod insertion	
To shut down the reactor by automatically inserting the control rods after detecting an abnormality (high pressure, low water level in the reactor) by the instrumentation and control system, which is installed aside from the existing emergency shutdown system.	
Alternative reactivity control	
To conduct the recirculation pump trip and insert control rods by water level and pressure of the reactor with the use of an RPS signal.	
Alternative water injection	
It sprays water and removes heat when the emergency core cooling system does not function for some reason. In accordance with the original function, there is water injection to the high-pressure reactor and cooling of the containment vessel. A control rod drive hydraulic control system and reactor coolant clean-up system are used to conduct alternative water injection to the high pressure reactor, and the condensate make-up water system, the fire protection system, dry well cooler and the containment & vessel cooling water system are used to cool the containment vessel.	
Automatic depressurization system	ADS
One of the emergency core cooling systems, it refers to the back-end unit of the high pressure core spray system or the high pressure coolant injection. Its purpose is to lower the reactor pressure and facilitate the water injection of the low pressure injection system by opening the main steam relief safety valve installed in the main steam line.	
Auxiliary seawater system	ASW
A system for feeding seawater to the heat exchangers for the facilities which feed cyclically cooling fresh water to the process heat exchangers, bearing coolers and air-conditioners in the plant.	
B equipment	
Equipment which has to be worn when entering zones that could be contaminated with radioactive substances.	
Back wash valve pit	
A place where valves are installed for reversing the flow of the seawater in the tube to clean the condenser tubes.	

Boiling water reactor	BWR
It mainly uses enriched uranium as nuclear fuel and water as a moderator and coolant. Steam is sent directly to the steam turbine without going to the heat exchangers. The steam which contains radioactive substances is sent to the steam turbine.	
Bottom of active fuel	BAF
Bottom of the fuel assembly.	
Charcoal filter	
A filter filled with granular activated charcoal to remove the radioactive iodine. While iodine is removed by activated charcoal by the effect of physical absorption, it is often the case that some chemical material is added to the activated charcoal in order to absorb iodine compounds that are difficult to absorb such as methyl iodide.	
Circulating water pump	CWP
Steam that has been used in the main turbine is cooled down and condensed in the main condenser. Seawater is used to cool down the steam and is fed to the seawater system (circulating water system) by this pump.	
Cold shutdown	
It refers to the condition where the temperature of the core water is less than 100°C and the reactor mode switch is placed in "Start-up," "Shutdown" or "Refueling."	
Condensate and feed water system	
A system for pressurizing and heating condensate steam condensed by the condenser and feeding it to the reactor.	
Condensate storage tank	CST
A tank for storing the water of the condensate water system. It is used for feeding condensate, storing surplus condensate and make-up water and others. In BWR, it is used as water source for the emergency core cooling system.	
Condenser	
Seawater cooler for condensing the steam which has acted in the steam turbine. It reduces the final pressure of the turbine drive steam by the obtained high vacuum and expands the heat drop resulting in the improvement of the turbine efficiency.	
Constant rated electric power operation	
An operating mode to maintain a steady level of electric power output.	
Constant rated thermal power operation	
An operating mode to maintain a steady level of thermal power, in which the electric power output fluctuates depending on the environmental conditions such as the seawater temperature.	
Containment Cooling system	CCS
A device to cool down the energy of the coolant leakage and the decay heat of the fuel by spraying water in the containment vessel in order to prevent the pressure and temperature of the inside the containment vessel from exceeding the maximum operating temperature at the time of a loss of coolant accident. At the same time, it helps eliminate iodine in the containment vessel and reduce iodine leakage from the containment vessel.	
Control rod drive	CRD
A device for taking control rods into and out of the reactor core. Hydraulically-powered drives are generally adopted for BWRs. (For advanced BWRs, electrically powered drives are also used concurrently.)	

Control room air handling and ventilation system	
A system for maintaining a clean atmosphere in the control room by automatically isolating the room from the external air and by recirculating the air in the room, when a leakage of radioactive material takes place.	
Core	
It refers to the area where nuclear fuel is located and the chain reaction of nuclear fission takes place in the reactor. It consists of nuclear fuel and a moderator, among which coolant is traveling.	
Core spray system	CS
A system which is part of the emergency core cooling system of a BWR. It sprays water to the upper part of the fuel to cool it down at the time of a loss of coolant accident.	
Decay heat	
Heat generated when the atomic nucleus of a radioactive substance spontaneously transforms to another atomic nucleus.	
Demineralized water tank	
Tank for storing the demineralized water which is obtained by demineralizing the water from rivers or dams with the use of a demineralizer. It is used for the system that needs water of which quality is controlled.	
Diesel driven fire pump	D/D FP
Diesel driven pumps installed in the fire protection system. They are automatically to start, when the pressure in the fire protection system becomes low or electric-motor-driven fire pump cannot operate.	
Diesel generator	DG
A generator which feeds power to facilities necessary to safely shut down the power plant at the time of loss of normal power of the plant. It is driven by a diesel engine.	
Disconnect switch	
A device to disconnect the circuit for the safe checking work. Its capability to disconnect is originally low and basically it cannot switch the load current. It is equipped with an interlock so that equipment operation is not possible unless the breaker is open.	
Dry well	D/W
Space other than the suppression chamber in the containment vessel.	
Dry well cooler	DWC
Facility which cools the dry well while the reactor is operating and also cools during the periodical inspection to avoid a severe temperature rise in the containment vessel.	
Duct	
It serves as path for air or as a flow channel for water and gas.	
Dust extractor	
A device for extracting dust contained in the obtained seawater.	
Earthquake-proof class	
Classes according to the importance of the facility, determined in the importance classification concerning the aseismic design.	
Electric magnetic valve	
A valve which is opened and closed by the electromagnetic power.	

Emergency core cooling system	ECCS
Engineered safety features intended to effectively cool down the reactor core even when a loss of coolant accident takes place in the reactor. It has a volume sufficient to cool down the reactor core, regardless of the size of the pipe rupture on the primary cooling system for the reactor. It is comprised of a high pressure core spray system, high pressure core injection system, low pressure core spray system, low pressure core injection system and automatic depressurization system. (In the case of advanced BWR, the reactor core isolation cooling system is included in the ECCS.)	
Emergency equipment cooling water system	EECW
A facility to feed the cooling fresh water to emergency diesel generators and the coolers of emergency ventilation equipment so that every piece of emergency equipment can maintain its required function at the time of a loss of coolant accidents. (It also feeds the cooling water to residual heat removal pump motor.)	
Engineered safety features	
It refers to the facilities designed to have functions to contain or prevent the release of considerable radioactive material caused by a fuel failure or such like in the reactor, which are brought about by some damages or failure to the reactor facilities.	
Enhanced pressure resistant vent	
A containment vessel vent line of high pressure resistance, which was prepared as measures against severe accidents. There are two vent lines for D/W and S/C, each of which has big and small valves of AO valve. After the confluence of two lines, the MO valve and the rupture disk are placed and the converged line further connected to the vent stack. The word "containment vessel vent" in this report refers to the vent from this enhanced pressure resistant vent line.	
Fail-safe	
To ensure safety even when a failure occurs. It means that devices are designed to keep safety without endangering the original function even when part of the device fails or a failure takes place in the function of the safety protection device.	
Filtered water	
Water from rivers or dams is used after processing as the water for the plant. It is used in the systems which do not need high quality water.	
Fire protection system	FP
Fire protection system in a power plant. Besides the normal fire hydrants, carbon dioxide extinguishing systems for oil fires and others are available.	
Fire-resistant clothes	
Clothes which are difficult to burn.	
Flashing	
To wash radioactive substances away from piping with clean water to reduce the dose.	
Fuel Pool Cooling and Filtering system	FPC
Fuel assemblies taken out of the reactor need to be cooled down in the fuel pool, because the fission products they contain emit heat and radiation. It is a purification system for removing the impurities and maintaining the water quality, while cooling down the water of the pool.	
Fuel cladding tube	
A thin-walled circular pipe used as cladding material for the fuel rod. A zirconium alloy or a stainless steel pipe is adopted. Fuel cladding tubes are placed between fuel and coolant and play an important role in maintaining the integrity of the fuel. It is one of the five layer barriers and dissolved when reaching a temperature of 1800 degrees.	

Fuel day tank	
Light fuel oil, which is fuel for emergency diesel generators, is transferred from the light oil tank outside to the fuel day tank located in the building where the emergency diesel generators are found. A necessary stockpile for each tank according to the operation time is decided in safety regulations.	
Full-face mask	
One of the purification respiratory protection tools. It covers all of the face.	
HPCS Closed Cooling Sea Water System	HPCW
A system which feeds seawater to the heat exchanger of the facilities which cyclically feed freshwater to the cooler for the motors of the high pressure core spray system, bearings and oil cooler.	
Heat sink	
A cooling source for securing the heat removal function (heat release).	
High pressure coolant injection system	HPCI
One of the emergency core cooling systems, which, with the use of steam-turbine-driven high pressure pump, injects cooling water into the reactor core in the time of the accident where the break of the piping is relatively small and the reactor pressure does not rapidly fall. The flow (i.e., capacity) of the pump is approximately 10 times larger than that of the reactor core isolation cooling system, but smaller than that of the reactor shutdown cooling system and the residual heat removal cooling system ( approximately 1800 m <sup>3</sup> /h, for Units 2 to 5 of the Fukushima Daiichi Nuclear Power Station). It is installed in Units 1 to 5 of the Fukushima Daiichi Nuclear Power Station.	
High pressure core cooling function	
High pressure core cooling function including the high pressure core spray system, the high pressure core injection system and others.	
High pressure core spray system	HPCS
One of the emergency core cooling systems, which has an independent power source (diesel generator) in the time of the accident in which the reactor pressure does not rapidly fall and sprays with the use of an electric-motor-driven high pressure pump to the reactor core for cooling.	
In-core instrumentation piping	
Instrumentation and equipment for measuring in the reactor the process volume needed for monitoring the control, safety and conditions of the reactor. It is a general name for an in-core neutron flux monitoring system, coolant flow monitoring system, control rod position monitoring system and others.	
Independence	
To design a system for operation and system for safety separately so that a failure on one system does not affect the other.	
Industrial television	ITV
TV camera installed for reducing the exposure of the plant worker, monitoring the operation and leakage of radioactive fluid, monitoring the alarm of the local control panel, monitoring the situation of the water intake structure in the winter time and others. Cameras installed for site monitoring in the industry are generally called ITV.	
Inflammability limit	
Breaking point of the gas concentration of hydrogen and oxygen generated by metal-water reactions or radiolysis of water in the time of the loss of coolant accident, above which combustion occurs.	
Instrument air system	IA

A system which feeds the clean and dry compressed air for the air operated valves, air-regulated devices and measuring instruments.	
Iodine preparation	
<p>Since the thyroid has a function to absorb and accumulate iodine, radioactive iodine is instantly combined with the thyroid hormone in the thyroid, which keep emitting the radiation inside the body, once the radioactive iodine in the atmosphere is absorbed in the human body. As a result, disorder of the thyroid gland caused by the radiation leads to development of goitrous tumor or hypothyroidism as late radiation injury.</p> <p>In order to prevent this disorder, people need to take iodine without radiation before being exposed in order to saturate thyroid with iodine without radiation so that the thyroid with radiation is not be taken into the thyroid, even if exposed internally. Thus a preventive effect can be expected.</p>	
Isolation condenser	IC
A heat removing device for the reactor at the time of the isolation of the core in the boiling water reactor. It cools down the reactor steam with the water of the secondary system and returns the condensate to the reactor by natural circulation. (Only installed for the Fukushima Daiichi Nuclear Power Station and Unit 1 in the Tsuruga Power Station.)	
Leak	
Leakage	
Loss of coolant accident	
One of the credible accidents of the reactor. In this accident coolant in the reactor pressure vessel is lost because of the damage of piping or other reasons. Cooling of the reactor is not possible because the coolant is lost from the reactor pressure vessel.	
Low pressure core cooling system	
Low pressure emergency core cooling systems. They include a low pressure core injection system, low pressure flooder system, low pressure core spray system and others.	
Lower plenum	
Space found in the lower part of a reactor core. During normal operation, water which flows down between the inside wall of the reactor pressure vessel and the core shroud or along the primary loop recirculation system to this space, where it turns back into the core to cool down. In the lower plenum, monitoring guide tubes and control rod guide tubes are found.	
Main control room	MCR
A room where a main control board, on which monitoring and operating devices necessary for the operation of the main system of the plant are collected, is placed and plant workers carry out the monitoring, control and operation in a centralized manner.	
Main steam isolation valve	MSIV
Valves installed in the main steam line, which close up when it is needed to isolate the reactor from the turbine facility.	
Makeup Water System (Condensated)	MUWC
A system for feeding the various types water (The water source is the condensate storage tank. The water is the purified water which has been used in the reactor. Though it contains some amount of radioactive substance, its dose is low.) necessary for operation of the plant by using pumps (condensate water transfer pump). It is not for emergency, but it is injected to the reactor in the implementation of the accident management. The flow volume of the pumps is smaller than those of the reactor core isolation cooling system (approximately 70 m <sup>3</sup> /h).	
Makeup Water System (Purified)	MUWP
A system feeding to the equipment, piping, valves and others installed in buildings, auxiliary facilities and others the make-up water with necessary volume and pressure, which is needed for the smooth operation and maintenance of a power plant.	

Maximum response acceleration	
Maximum value of acceleration of the vibration (response) of the structure when the seismic motion acts on that structure.	
Melted fuel	
Fuel assembly melted by high temperature, which became a lump.	
Metal-clad switch gear	M/C
A power panel used for high-voltage circuit in the plant, in which the electromagnetic breakers, vacuum breakers, protective relay and auxiliary instruments are compactly housed. It consists of regular, common and emergency switches.	
Metal-water reaction	
When zirconium used for the fuel cladding is heated, it gradually reacts with the surrounding coolant, which is water and becomes oxidized. This reaction produces hydrogen gas.	
Monitoring post	MP
They are placed in several places in the plant and monitor the rate of atmospheric gamma dose. The vehicle which can monitor is called monitoring car.	
Motor control center	MCC
A power panel used for low-volume low-voltage circuits in the plant, in which line breakers, magnetic contactors and protective relay are compactly housed. It consists of regular, common and emergency switches.	
Motor operated valve	MO valve
A valve whose driving parts for opening and closing are operated by a motor.	
Multiplicity	
To prepare more than two systems or pieces of equipment of the same function and the same quality.	
Nonessential	
A system used normally	
Nuclide	
A term used to refer to types of atom or nucleus.	
Nuclide analysis	
To identify radionuclide from sample	
Off-site Center	
Facilities predesignated by the competent minister provided in Paragraph 1, Article 12 of the Special Law of Emergency Preparedness for Nuclear Disaster in order that the related personnel from the national, prefectural and municipal governments and other organizations meet together and that the local nuclear emergency response headquarters of the national government and the disaster countermeasures headquarters of the prefectural governments share the information in the time of nuclear disasters with a view to conducting concerted emergency measures and promoting the coordinated and smooth implementation of nuclear disaster countermeasures. Its legally official name is the Emergency Response Operation Facilities.	
On-site power	
AC power distributed to equipment and others in a power plant.	
Onahama Pile	O.P.
Datum level 0.727 m lower than the Tokyo Pile.	
Paging	

A facility of in-house communication consisting of handset stations and speakers placed in many places in the plant. It is easy to use and enables clear broadcasting and telephone calls in a very noisy environment.	
Pellet	
A highly compacted small cylindrical substance containing the fissionable material. It is one of the five layer barriers. It is generally made by compacting the oxidation product with high pressure, sintering it and making it into ceramic form. A fuel rod is made by putting them into the fuel rod cladding.	
Pier	
A part of the port facilities in the plant. It is the place for unloading the cargo carried by ships.	
Pool gate	
Gates for separating the spent fuel pool, the reactor well and the steam-water separator pool. During the periodical inspection, the in-core structures such as steam-water separator are transferred to the steam-water separator pool and the loaded fuel is transferred to the spent fuel pool after removing the lid of the reactor pressure vessel. Since those pieces of equipment or devices have a very high dose, they are transferred from one pool to another under the water, securing a biological shield wall.	
Power center	P/C
A facility for controlling electromotor loads, motor control center loads and others of intermediate capacity less than 600 V source voltage at one place in a centralized manner. It is comprised by arranging in one board units into which air circuit breakers and protection equipment.	
Pressurized Water Reactor	PWR
Type of nuclear reactor in which water, which is used as moderator and coolant, is highly pressurized to suppress boiling of water. Primary cooling system that is to retrieve the thermal energy generated in the core and secondary cooling system that is to generate steam is completely separated by the heat exchanger (steam generator).	
Primary Containment Vessel Cooling Seawater System	
A system supplying seawater to the components of the containment cooling system	
Primary Containment Vessel Vent	PCV Vent
A device to decrease the pressure inside the PCV by partially releasing the gas containing radioactive materials (mostly nitrogen) from the PCV in order to prevent the pressure from increasing abnormally and to protect the PCV.	
Primary Containment Vessel	PCV
A vessel housing reactor-related components and piping including reactor pressure vessel. This vessel needs to have a capability to resist a transient pressure and temperature which occur in the time of pipe rupture accident of reactor-related piping (what is called a Loss of Coolant Accident) and to maintain the post-accident integrity and has the leak-tightness for minimizing the leakage of the radioactive material from the vessel as low as possible. This is one of the five-layer barriers.	
Primary containment isolation system	PCIS
This system operates so that the pressure vessel is isolated in the time of the fuel damage accidents, that the isolation valves between the reactor pressure vessel and the damaged part close to prevent radioactive materials and coolant from leaking in the time of a break accident on the primary system outside of the containment vessel and that the release path of radioactive materials is shut to contain them in the containment vessel in the time of a break accident on the primary system inside the containment vessel.	
Probabilistic Safety Analysis	PSA
To assess the safety in consideration of the probability of various possible events	

Process computer	
<p>A computer for performing the process control, monitoring and controlling the process volume and arithmetic processing. The connection with the plant process volume is performed through the process input-output units and generally highly reliable computers are used, because high operational availability and effectiveness are required. In the nuclear plant they are installed for monitoring the process volume, calculating the core performance and the plant performance and often applied as systems having the plant operation supporting function. They are installed with the diagnosis function.</p>	
RHR cooling water system	RHRC
<p>A system which feeds cooling freshwater to the heat exchangers and the pumps of the residual heat removal system, mechanical seal coolers of the pumps of the low pressure core spray system and others.</p>	
Rapid depressurization	
<p>An operation to decrease the reactor pressure by opening the main steam safety release valve manually in order to supply water from low-pressure emergency core cooling system into the reactor.</p>	
Reactor building	R/B
<p>A building housing a reactor and its related facilities. This is one of the five-layer barriers.</p>	
Reactor building closed cooling seawater system	RSW
<p>Cooling water of the reactor building closed cooling water system cools through a heat exchanger. This system is feeding seawater for cooling down the cooling water of the reactor building closed cooling water system.</p>	
Reactor building closed cooling water system	RCW
<p>One of the component cooling systems. Cooling system for reactor-related non-safety components or cooling system for reactor-related non-safety and safety components.</p>	
Reactor coolant pressure boundaries	
<p>It refers to the zone where during the normal operation, the reactor coolant is included and the same pressure condition as the reactor. It forms a pressure barrier for the primary cooling system, breakage of which leads to the loss of coolant accident. It usually includes the reactor pressure vessel, primary piping and others, but it does not refer to the part that is isolated in the time of the loss of coolant accident.</p>	
Reactor core isolation cooling system	RCIC
<p>During the normal operation, when the main condenser somehow cannot be used due to the close of the main steam isolation valve or other reasons, the turbine-driven pump should be operated by steam of the reactor to feed the cooling water to the reactor in order to remove decay heat of the fuel and reduce pressure. When the water feeding system is out of order, the system is used as auxiliary water feed pump to maintain water level of the reactor. Since the source of power is steam generated by the reactor, this system cannot be operated without a certain level of the reactor pressure. The source of water is either the condensate storage tank or the suppression pool. Since steam is discharged to the suppression pool after the start of the turbine, the temperature in the suppression chamber and the suppression pool rises during the operation of this system. Therefore the operation of this system needs to be coordinated with the residual heat removal system to prevent the temperature from rising.</p>	
Reactor mode switch	
<p>A switch for selecting the interlock according to the situation of the reactor. Modes include "Operation," "Start-up," "Shutdown" and "Refueling."</p>	

Reactor pressure vessel	RPV
A vessel in which a reactor core, in-furnace structure, primary coolant and others are housed and steam are generated by nuclear reaction of the fuel.	
(Reactor) Subcritical	
To stop the chain reaction of nuclear fission by totally inserting control rods, which is a shutdown function at the time of the reactor scram. It is possible to shut down the reactor safely by the subcritical operation.	
Receiving circuit breaker	
Device for isolating the troubled circuit when an accident occurs on the transmission network.	
Reference surface	
Water is held to take a reference pressure for measuring the water level inside the reactor pressure vessel.	
Residual heat removal seawater system	RHRS
Cooling water of the residual heat removal system cools through a heat exchanger. This system feeds seawater for cooling down the cooling water of the residual heat removal system.	
Residual heat removal system	RHR
<p>A system for removing and cooling the decay heat and the sensible heat generated by the core after the shutdown of the reactor. It is operated in the below-mentioned operation modes according to the composition of valves: Shutdown cooling system, Low pressure coolant injection system, Containment vessel spray system, Suppression pool cooling system and Spent fuel storage pool cooling system.</p> <p>It's often the case that the alternative water injection as a countermeasure against severe accidents injects water into the reactor or the containment vessel with use of the piping of the residual heat removal system.</p>	
Rupture disk	
Quaquaversal metal board which is intended for preventing the air-tight devices such as the pressure vessel, rotating devices, piping and ducts from breaking because of excessive or negative pressure. It is a safety device, which is to break at a designed pressure, to release the abnormal pressure in the facilities by rupturing.	
Safety relief valve	SRV
A valve which discharges steam to the suppression pool automatically or in a manual manner from the control room for protection of the reactor pressure vessel when the reactor pressure rises abnormally (discharged heat is cooled down and condensed in the suppression pool), and additionally has function of ADS (Automatic Depressurization System) of ECCS (Emergency Core Cooling System).	
Scram	
It refers to a prompt shutdown of the reactor by automatically inserting negative reactivity to the reactor, when the signals of the detectors installed in the reactor exceed the limit of the range of operational conditions. Normally it is caused automatically by the safety devices of the reactor. Setting items of the predetermined conditions for scram, which is called scram conditions, include abnormal increase of output of the reactor, seismic acceleration and turbine trip. It is a generic term for emergency shutdowns.	
Sea Water Heat Exchanger Building	
Building housing pumps supplying seawater to heat exchangers of various types of fresh water cooling system, heat exchangers and others.	

Self-air set	
One of the respiratory protection tools, which feeds air from a portable cylinder. It is used for preventing the holder, who is in the atmosphere of high concentration of radioactive materials, from inhaling radioactive materials in the air.	
Cesium iodide	
An inorganic compound whose composition formula is CsI. It is the metal halogen compound which consists of cesium, which is an alkali metal, and iodine, which is a metal halogen. For scientific purpose, it is used as an X-ray fluoroc-magnifying pipe and as single crystal for detecting gamma rays. It is also used in the simple radiation measuring device "Hakarukun." Radioactive iodine generated in the reactor is emitted from the core to the containment vessel as CsI and most of it is absorbed in water.	
Severe accident	
An event, in which sufficient cooling of the reactor core and control of the reactivity cannot be realized by the measures assumed by the assessment of the safety design, considerably exceeding the design basis event and resulting in significant damages of the reactor core. The significance of a severe event depends on the degree of damages or the degree of loss of integrity of the containment facility.	
Shared auxiliary operational facilities	
Shared spent fuel pool in the Fukushima Daiichi Nuclear Power Station and buildings housing the emergency diesel generators for units 2 and 4 of the Fukushima Daiichi Nuclear Power Station.	
Shroud	
A cylindrical structure housing fuel assemblies and control rods constituting the core part.	
Shutdown cooling system Shutdown cooling mode	SHC
Facility for removing decay heat by cooling the coolant (reactor water) with the use of pumps and the heat exchanger after the shutdown of the reactor. It has capability to implement the cold shutdown. The pump flow is large and the heat exchanger is highly capable. (All units other than Unit 1 in the Fukushima Daiichi Nuclear Power Station have the cooling system "Shutdown cooling mode" in RHR system.)	
Significant building with base isolation	
A building constructed to set up the disaster countermeasure headquarters when natural disasters such as earthquakes take place. It is made with the reinforced concrete structure and base isolation and consists of meeting rooms, communication facilities, power supply system, air-conditioners and others. It is designed so that the first break after the earthquake can be performed without any problems even when the earthquake of 7th seismic intensity.	
Simulator training	
Training on how to shut down safely a reactor by simulating transients and severe accidents with the use of computers.	
Skimmer level	
Water level of skimmer surge tank. Supernatant fluid of the spent fuel pool flows over the skimmer weir and is guided to the skimmer surge tank. It is needed to maintain the suction pressure of the pumps of the spent fuel pool cooling and purification system, and water quality of the pool by removing the floating objects from the pool surface.	
Special Law for Nuclear Emergency	
An abbreviated name for Special Law of Emergency Preparedness for Nuclear Disaster.	
Spectrum	
It generally refers to an array of components laid out in quantitative order of some characteristics after breaking down an object of complex compound into components.	

Spent fuel pit	SFP
A pool for storing fuel taken out from the reactor. Besides spent fuel, fuel taken out for the periodical examination, neutron source, damaged fuel and others are stored there. Water plays a role of biological shield and removes decay heat. Quality of water is maintained by the spent fuel storage pool and filtering system.	
Stack	
Facilities intended to discharge and diffuse the radioactive gaseous waste into the air. The discharge of radioactive gaseous waste is regulated by the stipulation of the law down to the predetermined volume, and it is discharged from stacks into the atmosphere.	
Stand-by gas treatment system	SGTS
A facility, which is one of the engineered safety features, to automatically shut down regular ventilation systems and reduce the external emission of the radioactive iodine and radioactive material in particulate form while keeping the negative pressure inside the buildings, when a radioactive leakage accident takes place.	
Stand-by liquid control	SLC
A back-end system of the control rod drive system, which shuts down the reactor by feeding sodium tetraborate solution which can absorb a lot of neutron when it is impossible to insert control rods for some reason.	
Standard earthquake ground motion (Ss)	
An earthquake ground motion employed in the seismic design of a nuclear power plant. It is the earthquake ground motion which is properly assumed to have a probability to, though extremely rarely, occur during the period of the operation and a significant impact on the facilities from the viewpoint of seismology and earthquake engineering considering geological condition and structure and earthquake activity in the vicinity of the site. Both hypocenter-specified and hypocenter-not-specified standard earthquake ground motions on the free bed-rock surface in the site are to be prepared in horizontal and vertical directions respectively. Safety functions of the aseismatically important facilities need to be maintained in the face of seismic force of these standard earthquake ground motions Ss.	
Station black out	SBO
A loss of AC power, which is a necessary source of power for the power plant, for some reasons. Source of AC power includes external power supplies and emergency diesel generators.	
Suppression Chamber, Suppression Pool	S/C, S/P
The systems, adopted only in Boiling Water Reactors (BWR), constantly hold water of approximately 4,000 m <sup>3</sup> (in case of units 2 to 4 of The Fukushima Daini Nuclear Power Station). In case that cooling water in the reactor pressure vessel is reduced by some accident and the steam pressure is increased, these systems decrease the pressure inside the pressure vessels by guiding the steam through the vent pipes to the pressure chamber to cool it down. They are also utilized as a source of water for the emergency core cooling system.	
Survey	
To explore the presence of radioactive material and measure its dose.	
Switching Station	
Staging station set up for transmitting electric power generated by electric power stations to the power supply system and for bringing it from power system into the plant. Switching of the power supply system is made by switches.	
Temperature falling rate	
Fall rate of temperature per hour.	

Thermocouple	
A sensor for detecting the temperature difference. When two different types of metal are connected, voltages according to the different temperature are generated at the two connecting points due to the different thermopower of each type of metal and an electric current flows in a certain direction. This is a temperature sensor using a phenomenon (Seebeck effect) in which thermoelectromotive force arises because of the temperature difference between the two connecting points of different types of metal.	
Top of active fuel	TAF
Zero point of the fuel level instrument. It refers to the top of the pellet of the fuel assembly.	
Torus room	
A room which houses the doughnut-shaped tunnel (suppression chamber) containing water source for the emergency core cooling system. Since the shape of this tunnel is called torus, the room housing is called torus room. In the torus room piping other than the suppression chamber are also installed. The torus room is placed at the lower part of the containment vessel, surrounding it.	
Total black out	
A loss of both AC and DC power	
Transient Phenomenon record Server	
A server which ceaselessly records data of main parameters of the plant operation, automatically stores the data before and after the event when their values exceed or fall below the manually or previously set ranges, and supports the event analysis afterwards.	
Trench	
A tunnel intended to lay cables between buildings.	
Turbine Building Closed Cooling Water System	TSW
A system for feeding seawater to the heat exchanger of the turbine auxiliary cooling water system, which cools down turbine auxiliaries bearing, oil coolers, air conditioners and others with circulating fresh water.	
Turbine building	T/B
A building for housing main turbines, generators, main condensers, reactor feed water pumps, turbine auxiliaries and others.	
Ultimate heat sink	UHS
A final disposal place which removes and releases the heat collected from the fuel (decay heat) and operating machines. Usually the heat is removed through heat exchangers and disposed in the sea.	
Vent line nap	
Composition of system for vent.	
Ventilation system of Primary Containment Vessel	
= drywell cooler	
Void	
Air bubbles generated when boiling.	
Water radiolysis	
Water is decomposed by irradiating ionizing radiation into hydrogen and oxygen.	
Zirconium-water reaction	
Same as metal-water reaction. When zirconium used for the fuel cladding is heated, it gradually reacts with the surrounding coolant, which is water, and becomes oxidized. Oxidized zirconium cladding becomes brittle and generates hydrogen.	

## Table of Contents

Introduction .....	1
Members of the Examination Committee.....	3
Deliberation Members of the Examination Committee on Accident at Fukushima Daiichi Nuclear Power Station.....	3
Report Study Members of the Examination Committee on Accident at Fukushima Daiichi Nuclear Power Station.....	4
Report Review Team of the Examination Committee on Accident at Fukushima Daiichi Nuclear Power Station.....	6
Abbreviations .....	7
Glossary .....	9
Chapter 1 Purpose.....	1-1
Chapter 2 Fukushima Daiichi Nuclear Power Station Accident Development....	2-1
2.1 Complete overview of Fukushima Daiichi Nuclear Power Station and accident.....	2-1
2.1.1 Overview of Fukushima Daiichi Nuclear Power Station.....	2-1
2.1.2 Overview of Great East Japan Earthquake and Tsunami.....	2-3
2.1.3 Overview of accident due to Great East Japan Earthquake.....	2-6
2.1.4 Impact of earthquake.....	2-11
2.1.5 Impact of tsunami.....	2-14
2.2 Course of accident at Unit 1 .....	2-18
2.2.1 Conditions from earthquake to arrival of tsunami.....	2-18
2.2.2 Situation of nuclear reactor building from tsunami to hydrogen explosion	2-19
2.2.3 Condition of nuclear reactor building after hydrogen explosion .....	2-24
2.2.4 Main events after accident .....	2-25
2.2.5 Status of spent fuel pool .....	2-25
2.3 Course of accident at Unit 2 .....	2-37
2.3.1 From occurrence of earthquake to arrival of tsunami.....	2-37
2.3.2 From arrival of tsunami to malfunctioning of pressure suppression chamber.....	2-37
2.3.3 Major events thereafter .....	2-42
2.3.4 Condition of spent fuel pool.....	2-43
2.4 Course of accident at Unit 3 .....	2-54
2.4.1 From occurrence of earthquake to arrival of tsunami.....	2-54
2.4.2 From arrival of tsunami to hydrogen explosion of the reactor building	2-54
2.4.3 After hydrogen gas explosion in the R/B.....	2-58
2.4.4 Major events thereafter .....	2-58
2.4.5 Condition of spent fuel pool.....	2-59
2.5 Course of accident at Unit 4 .....	2-69
2.6 Course of accident at Unit 5 .....	2-74
2.7 Course of accident at Unit 6 .....	2-78
2.8 Status of Dose rate Around Fukushima Daiichi Nuclear Power Station	2-80
2.9 Evaluation of Core Conditions of Unit 1 to Unit 3 at the Time	2-81
2.9.1 Evaluation of Core Conditions of Unit 1 at the Time of	2-81

Accidentaccident.....	2-81
2.9.2 Evaluation of Core core Condition condition of Unit 2 at the Time of Accidentaccident.....	2-82
2.9.3 Evaluation of Core core Conditions conditions of Unit 3 at the Time of Accidentaccident.....	2-83
Chapter 3 Analysis of Causes for Accident Events and Extraction of Problems..	3-1
3.1 Flow of Progress of Accident Events.....	3-1
3.2 Extraction of subject from accident event progress.....	3-4
3.2.1 Cause analysis from accident event progress (event tree).....	3-4
3.3 Arrangement of problems confirmed from a functional viewpoint .....	3-15
3.3.1 Causal analysis of the accident in unit 1 to 3 and management of issues	3-15
3.3.1.1 Problems by function.....	3-22
3.3.1.2 Problems related to common factors/failures .....	3-28
3.4 Causal analysis of the accident in unit 4 and management of issues .....	3-31
3.5 Management of the events in units 5 and 6.....	3-34
3.6 Comparison of progress of accidents of Fukushima Daiichi Nuclear Power Station with that of other stations.....	3-38
3.7 Causal analysis .....	3-42
Chapter 4 Lessons Learned and Measures To Take .....	4-1
4.1 Countermeasures against natural hazards .....	4-1
4.2 Securing of power supply .....	4-1
4.3 Measures against loss of heat sink systems .....	4-2
4.4 Measures against hydrogen leakage .....	4-2
4.5 Preparation for emergencies (training/drills) .....	4-3
4.6 Countermeasures against earthquakes/tsunamis (example measures) .....	4-4
4.6.1 Assumption of earthquake/tsunami strength.....	4-4
4.6.2 Protection of the site from tsunami.....	4-4
4.6.3 Protection of buildings.....	4-5
4.7 Preparation for power supply (example measures) .....	4-6
4.7.1 SBO and loss of DC power sources.....	4-6
4.8 Examples of measures addressing the heat sink loss .....	4-8
4.8.1 Water Injection to the reactors.....	4-8
4.8.2 Loss of seawater cooling .....	4-10
4.8.3 Containment vent .....	4-11
4.9 Hydrogen measures .....	4-12
4.10 Emergency preparedness (Especially training).....	4-13
4.10.1 Training.....	4-13
4.10.2 Air conditioning and shield at Central control room.....	4-14
4.10.3 Measurement during accidents.....	4-14
4.10.4 Emergency Operation Facility .....	4-16
4.10.5 Radiation control/working control.....	4-17
4.10.6 Organization/command or order .....	4-19
4.10.7 Communication.....	4-19
4.10.8 Environmental monitoring.....	4-20
4.10.9 Preparing disaster countermeasures (heavy equipment/rescue), emergency cooperative framework .....	4-21
4.11 Security of integrity of the spent fuel .....	4-23
4.12 Summary of the countermeasures .....	4-23

Chapter 5	Timeline of the Accident to the Present.....	5-1
Chapter 6	Conclusion.....	6-1
Appendix-1	A Comparison of the Development of the Accident at the Fukushima Daiichi Nuclear Power Station and at Other Stations (Detailed Version).....	App1-1
Appendix-2	Agenda for Future Review.....	App2-1
Appendix-3	Comparison with Government Report / NRC Task Team Report	App3-1
Appendix -4	MARK-I Containment.....	App4-1
Reference -1	Plant Overview .....	Ref-1

## Chapter 1 Purpose

The accident at the Fukushima Daiichi Nuclear Power Station that happened due to the major earthquake that took place on March 11, 2011, made us realize once again, how severe the consequences can be in the case of an accident at a nuclear power plant. It also destroyed the public's trust in nuclear technology, which had been built up till now by that industry. It is very important that we seriously consider why the nuclear power industry could not prevent such an accident and ensure that nuclear power plants are even safer so that serious accidents can be prevented.

Hence, we conducted an investigation by setting up the Fukushima Daiichi Nuclear Power Station Accident Investigation Committee in the Japan Nuclear Technology Institute. Our aim was to summarize the necessary countermeasures by gathering the lessons learned from the Fukushima Daiichi Nuclear Power Station accident and focusing all the efforts of the Japan nuclear power industry.

The investigation committee is formed of the Japan Nuclear Technology Institute, Tokyo Electric Power Corporation and manufacturers, and has proposed various necessary countermeasures by drawing lessons from this disaster and keeping a focus on the analysis of reasons. It has done so based on the information related to plant design and information accumulated from its experience operating power plants.

Presently, work to recover from the accident is going on in Fukushima Daiichi Nuclear Power Station, but at the same time, it is also necessary to execute countermeasures so as to ensure even more safety in the nuclear power plants functioning within the country. Likewise, the adequate countermeasures should be taken for the halted power plants.

The scope of the investigation covers from the occurrence of the earthquake to the tsunami and up to the release of radioactive material. It was based on all the information related to the Fukushima Daiichi Nuclear Power Station accident published by Tokyo Electric Power Corporation. The main purpose of the investigation was to analyze the reasons for the accident and investigate countermeasures with a view to ensuring policies to prevent accidents due to the tsunami, preventing such accident from escalating, and reducing their effects.

Based on the facts related to the development of the accident the analysis of the main cause for widespread of the accident was analyzed according to the event tree and topics were picked up. Moreover, the reason why the safety system could not work was organized in matrix format from the [stop], [cool] function screens ensuring safety and topics were picked up in such a way that no topic is missed.

Based on all these topics, lessons were extracted and a variety of concrete examples of countermeasures summarized.

Further, we are continuing to make investigations whenever we find new topics and continue to design countermeasures by giving importance to issues that should be tackled by the industrial world. We also decided that in the case of issues which need to be analyzed with the government or self-governing bodies, such as Bousai, we will continue investigations regarding how to deal with them as an enterprise.

Hereafter, we will keep proposing additional countermeasures so as to improve safety after conducting investigations and revising this report; if we identify new facts and find important topics.

# Chapter 2 Fukushima Daiichi Nuclear Power Station Accident Development

## 2.1 Complete overview of Fukushima Daiichi Nuclear Power Station and accident

### 2.1.1 Overview of Fukushima Daiichi Nuclear Power Station

Fukushima Daiichi is located in the north-east of Japan (latitude 37° North, longitude 141° East), It is located in Okuma and Futaba City of Fukushima Prefecture, which is approximately 225 km to the north of Tokyo and is facing the Pacific Ocean. (Population of Okuma city: approximately 11,500, Futaba City: approximately 6,900.)



The site area of the power plant is approximately 3,500,000 m<sup>2</sup>, in a semicircular shape stretching 1.5 km east-west and 3 km north-south. It is 35 m above sea level and is leveled at a height of approximately 10 to 13 m facing a flat beach and consists of 6 boiling water reactors (hereafter called BWR).

The arrangement of power plant premises is as shown below, units 1 to 4 are located in Okuma City and Unit 5 and Unit 6 are in Futaba City. The main office is located on elevated ground.

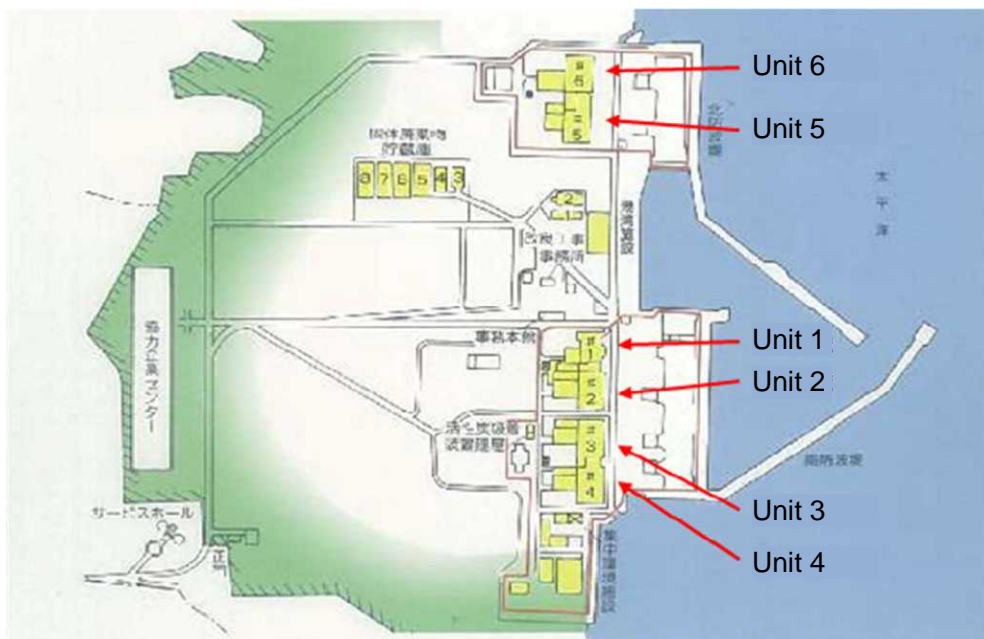

Each unit of the power plant units started operating in 1970 and the total power output is 4,696 MW. The salient features of each unit are described below.

Unit	Electric power (MW)	Operation start day	Reactor model	Container model	Reactor supplier
1	460	March 26, 1971	BWR-3	Mark I	GE
2	784	July 18, 1974	BWR-4	Mark I	GE, Toshiba
3	784	March 27, 1976	BWR-4	Mark I	Toshiba
4	784	October 12, 1978	BWR-4	Mark I	Hitachi
5	784	April 18, 1978	BWR-4	Mark I	Toshiba
6	1100	October 24, 1979	BWR-5	Mark II	GE, Toshiba

## 2.1.2 Overview of Great East Japan Earthquake and Tsunami

The earthquake took place at around 2:46 p.m. on March 11, 2011 with the epicenter located approximately 130 km to the east-south-east of Sanriku, Oshika Peninsula (latitude 38.1°N, longitude 142.9 °N)

- Scale: Moment Magnitude Mw 9.0
- Depth of epicenter: 24 km
- Aftershocks: 6 with a magnitude of more than M7.0, 93 with a magnitude of more than M6.0 (announcement on September 8 by meteorological agency).
- Maximum slippage: Approximately 30 m
- Rupture: Length approximately 450 km, width approximately 150 km
- Time of continuous destruction: Approximately 170 seconds

Earthquake of the coast of Sanriku at around 2.46 pm on March 11, 2011  
**Earthquake Distribution Diagram**

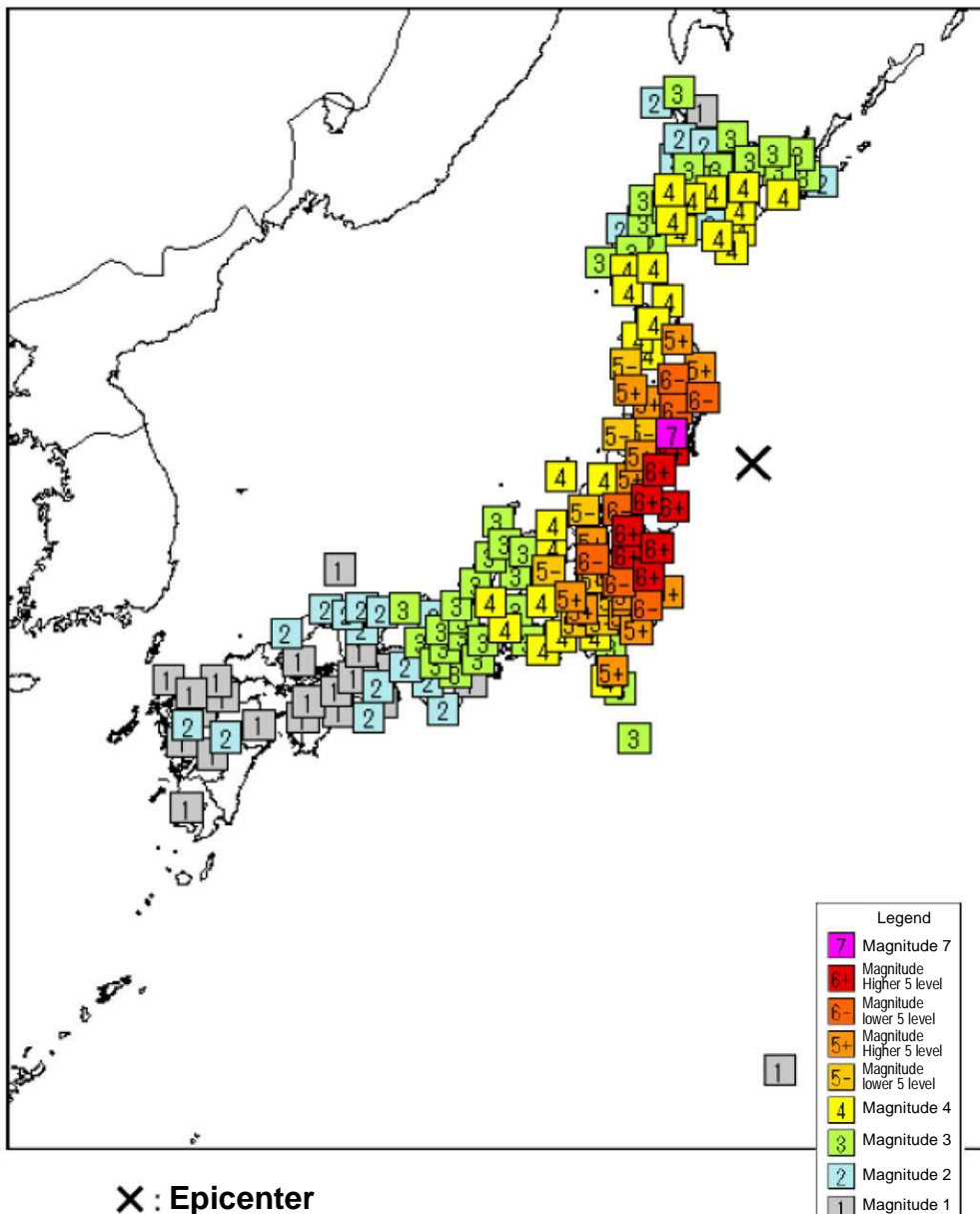

**X : Epicenter**

Source: Meteorological Agency

(About Sanriku earthquake which occurred at 14:46 on March 11, 2011)

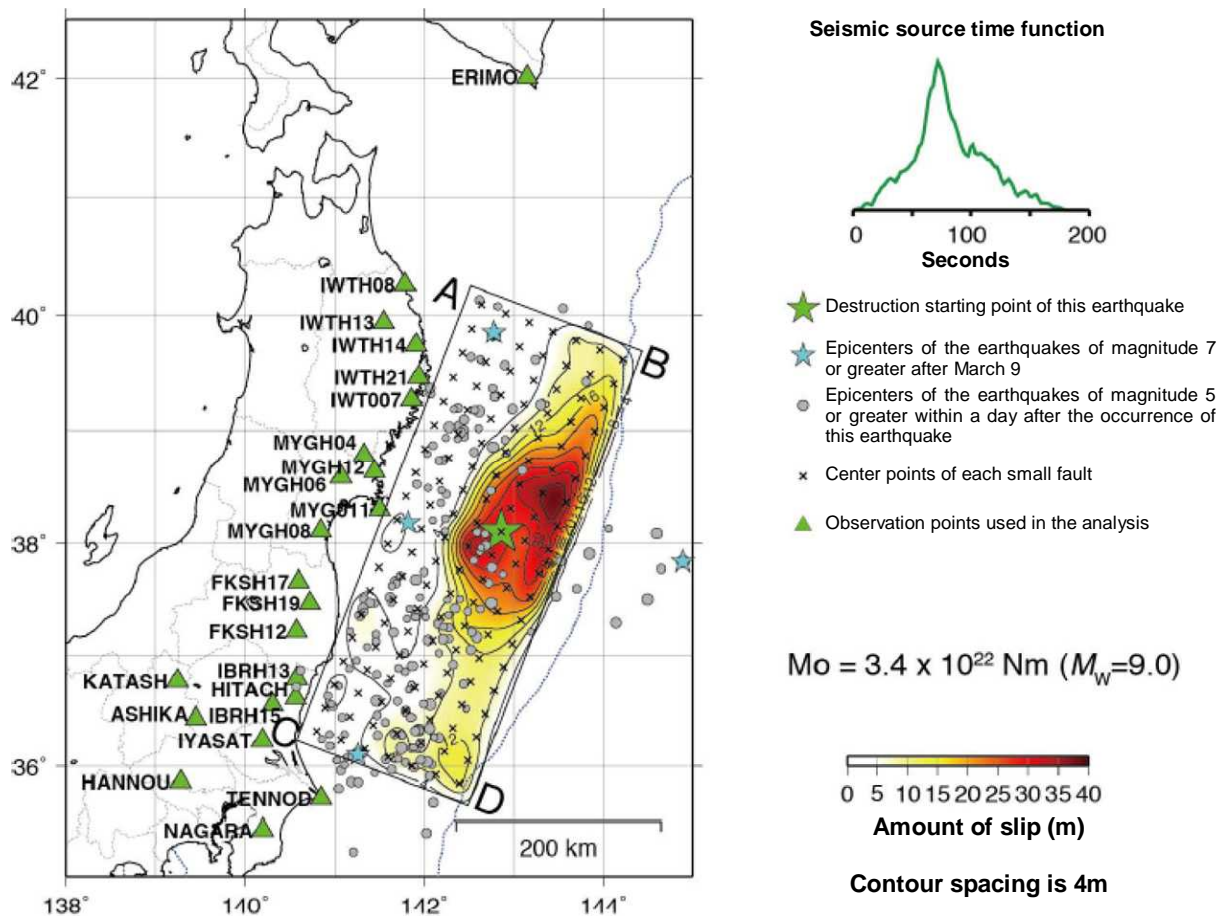

Source: Meteorological Agency (March 2011, earthquake, volcano monthly report)

It is presumed that the tsunami occurred when the sea floor rose roughly above the epicenter by approximately 3 m. The maximum height was about 35 m to the north of Miyako City. Also, the height of flood to the north of Miyako City has exceeded 25 m. The flood area has become 58 km<sup>2</sup> in Iwate Prefecture, 327 km<sup>2</sup> in Miyagi Prefecture, 112 km<sup>2</sup> in Fukushima Prefecture and 23 km<sup>2</sup> in Ibaraki Prefecture.

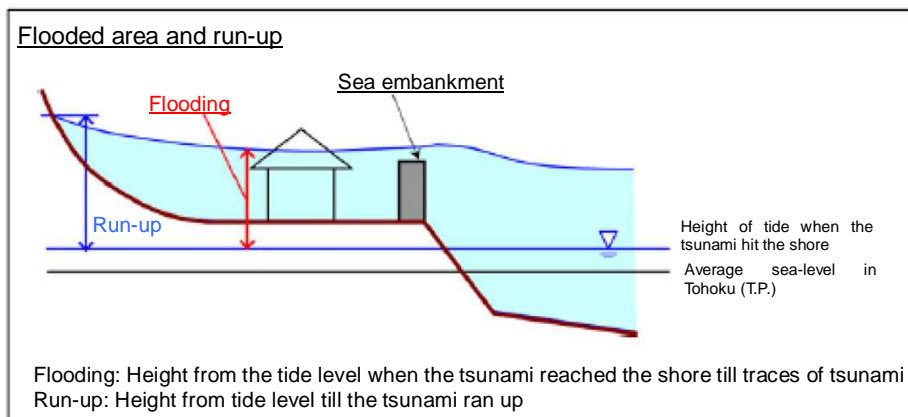
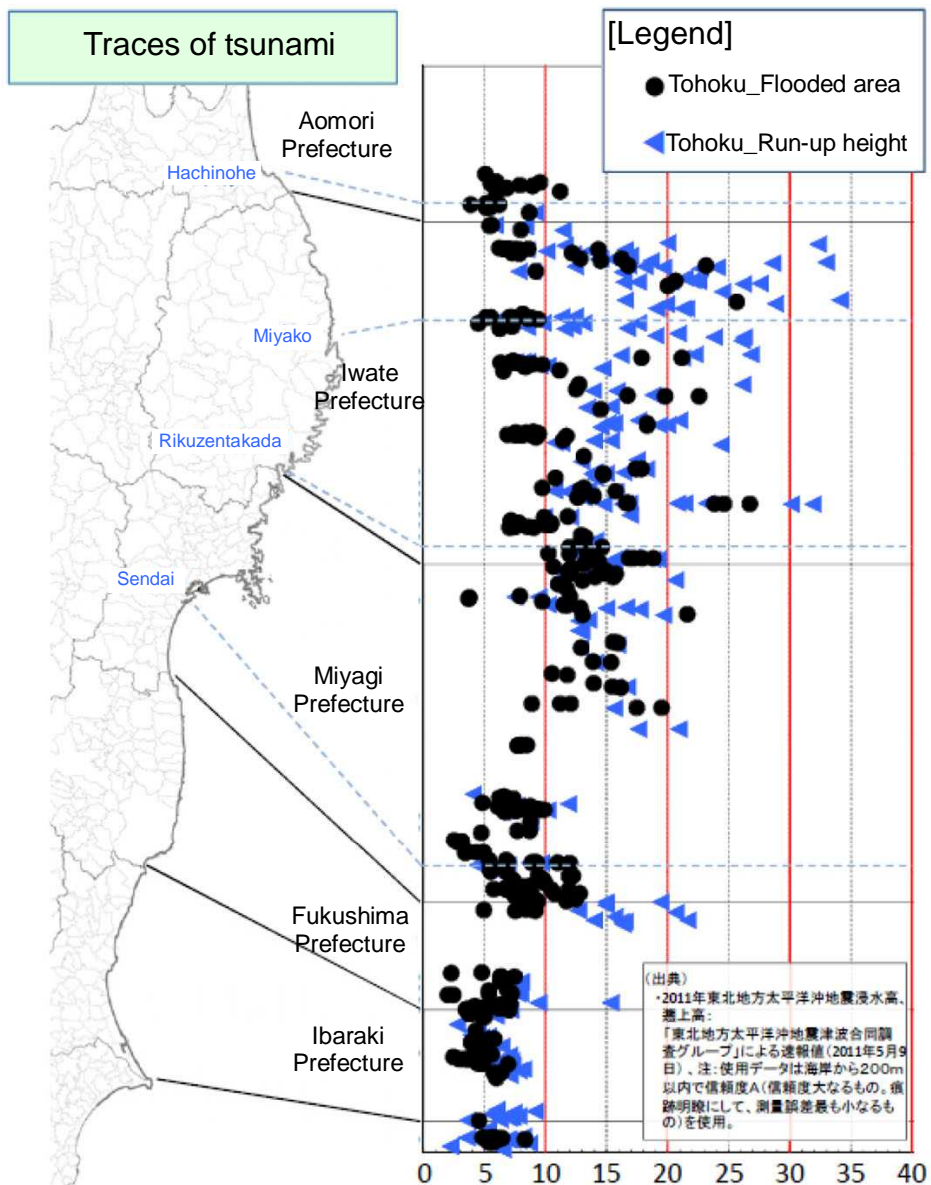

Source: Excerpts from First Special Investigation Committee Meeting related to earthquake and tsunami study of Great East Japan Earthquake

As of September 26, the damage due to the earthquake and tsunami is as serious as 15,811 deaths, with 4,305 people missing, and complete destruction of 117,542 buildings and partial destruction of 177,192 buildings.

### 2.1.3 Overview of accident due to Great East Japan Earthquake

When the Great East Japan Earthquake occurred on March 11, Units 1, 2 and 3 of the Fukushima Daiichi Nuclear Power Station were in operation, whereas units 4, 5 and 6 were not in operation; the spent fuel pool in Unit 4 was in a used up condition (hereafter termed as SFP) as its shroud was being replaced.

When the earthquake of magnitude 9 occurred at 14:46 on March 11, Units 1, 2 and 3, which were in operation, automatically stopped due to a [Peak Earthquake Acceleration] signal. The outside electric power supply was completely lost as the outside electric power supply facilities, circuit breakers, cables, steel power lines and such like got damaged or were destroyed due to this earthquake. Hence, all the units except Unit 4, which was undergoing a periodic inspection, automatically started to use a diesel engine generator (hereafter called “emergency use diesel generator”) and the cooling functionality of the nuclear reactor as well as SFP was maintained.

After that, all the emergency diesel generators, except the emergency DG 1 of the air cooling system of Unit 6, stopped operating as the emergency diesel generators, seawater pump and power supply equipment were all submerged in water due to a large tsunami. AC power supply to Units 1 to 5 was completely lost.

This large tsunami swept away heavy machines, tanks and such like in the flood water within the power plant, and a great deal of rubble was scattered on the roads; moreover, it became completely dark inside the premises, almost all the means of communication had stopped. In this situation, two workers who were conducting post-earthquake investigations in the turbine building (hereafter called “T/B”) of Unit 4, were lost and later confirmed to be dead.

In Fukushima Daiichi Nuclear Power Station, at 15:42 on March 11, the Station concluded that the situation corresponded to a particular phenomenon (complete loss of AC power supply) as per Article 10 of the Special Law of Emergency Preparedness for Nuclear Disaster (hereafter called “Special Law for Nuclear Emergency”) and the Station announce it to the national and local government bodies. Also, the power supply to measurement displays was also lost and hence it was not possible to determine the water level of the nuclear reactor or the flood conditions. Hence, the Station concluded that the situation corresponded to a particular phenomenon in which emergency core cooling equipment cannot inject water and announced this to the national and local government bodies at 16:45.

The summary of how the accident spread for all units is mentioned below.

After automatic shutdown of Unit 1, on March 11 at 14:47, the main steam isolation valve (MSIV) (hereafter called “MSIV”) stopped due to a loss of external power supply, the pressure of reactor pressure vessel (hereafter called “RPV”) rose, the emergency condenser (hereafter called “IC”) automatically started at 14:52. As per the operation manual, workers performed a control operation by repeating the manual operations (isolation valve open-close) of IC, so that the rate of decrease in RPV temperature did not increase above 55°C/h.

After this, all the AC power was lost and simultaneously the DC power was also lost due to a large tsunami that came at 15:37 on March 11. Hence, it was not possible to pump out the water in the nuclear reactor or confirm the status of the parameters. Hence, workers started preparing to use alternative water pumping methods. When the water level was restored at 21:19 on March 11, due to the

temporary recovery of the electricity supply, it was confirmed that the water level was above the available fuel level (hereafter called "TAF"). The radiation level of T/B rose around 11:00 on March 11. At 0:06 on March 12, workers were instructed to prepare for PCV venting by the nuclear power plant manager, as there was a possibility that the PCV pressure had exceeded the maximum allowed pressure. At around 5:46 on March 12, alternative pumping of water started. At 7:11 on March 12, the prime minister visited the power plant to make observations and returned to Tokyo at 8:04. The evacuation of residents of Okuma City (Kumachi-ku) was confirmed at 9:03 on March 12. At around 9:15, 25% of the monitor valve (hereafter called "MO valve"), which is one of the two valves in series in the PCV vent line, opened manually; after that we went towards the premises to open the other air operation valve (hereafter called "AO valve"), but it was not possible to do so due to high level of radiation. When the valves were opened from the main control room (hereafter called "MCR"), it could not produce a sufficient result and hence, a temporary air compressor was set up and the AO valve was opened. Thus, the PCV pressure reduced at around 14:30. After this, at around 15:36 on March 12, there was a hydrogen explosion (hereafter called "hydrogen explosion") in the upper part of the nuclear reactor building; the roof and outer walls were damaged. The injection of seawater into the nuclear reactor started at around 19:04 on March 12.

In the case of Unit 2, after it automatically shut down at 14:47 on March 11, MSIV stopped and the RPV pressure rose due to a loss of external power supply, but the pressure was controlled due to main steam safety relief valve (hereafter called "SRV"). The nuclear reactor water level control was done by the reactor core isolation cooling system (hereafter called "RCIC") and after repeated operations of manual start by the workers and auto -stop according to [nuclear reactor water level], once again RCIC was started manually at 15:39 on March 11. Immediately after this, at 15:41, the AC power was lost completely and at the same time, the DC power was also lost; hence, it was not possible to confirm the status of the water injection into the nuclear reactor or that of the parameters.. When the nuclear reactor water level was restored due to the temporary recovery of a power supply at 21:50, it was confirmed that the nuclear reactor water level had been maintained. The workers confirmed that the RCIC was functional when they checked the field instrument at around 2:00 on March 12.

The power supply recovery operation of the alternate water injection system was continued, but it was interrupted as the power supply cables were damaged due to the hydrogen explosion that occurred in Unit 1 at 15:36 on March 12. Moreover, the workers continued to prepare to inject seawater and they had laid a hose or fire engine, but it was damaged due to the hydrogen explosion in Unit 3 which occurred at 11:01 on March 14 and hence became unusable. Moreover, preparation work for a PCV vent, which was also in progress at the same time, was significantly affected by the explosion.

On March 14, at around 13:25, the Station concluded that the situation in the nuclear reactor was as per Article 15 of the Act on Special Law of Emergency Preparedness for Nuclear Disaster, due to a possibility that the RCIC had stopped due to the reduced water level. When radiation caused by the explosion in Unit 3 was spreading, the injection of seawater and preparation work for a PCV vent were started again. On March 14, at around 18:00, the pressure in the nuclear reactor began to be reduced due to SRV and at around 19:54 on March 14, the seawater injection started with a fire engine. The dry well (hereafter

called "D/W") pressure exceeded the maximum operating pressure at 22:50 on March 14. At around 6:00 on March 15, there was a sound of an impact and almost at the same time, the pressure inside the pressure control room (hereafter called "S/C") fell below 0 MPa [abs]. The pressure of D/W also fell below 155 KPa [abs] at 11:25 on March 15.

After automatic shutdown of Unit 3 at 14:48 on March 11, MSIV stopped due to the loss of external power supply, the RPV pressure rose but the pressure was controlled by the SRV. At 15:05 on March 11, the RCIC was started manually to control the nuclear reactor water level and the RCIC was stopped after that, corresponding to an indication [reactor high water level] which was due to a rise in the nuclear reactor water level at 15:25.

After that, the AC power supply was lost completely at 15:38 on March 11, due to a large tsunami. However, the RCIC and high pressure injection system (hereafter called "HPCI") operation was possible as the flood was avoided due to the DC power supply. The operation was continued by restarting the RCIC at 16:03 on March 11, but it automatically stopped at 11:36 on March 12. This resulted in a lower water level, HPCI started automatically at 12:35, corresponding to [reactor low water level] indication and recovered the previous water level. However, at 2:42 on March 13, the HPCI also stopped and RCIC also could not be restarted. Due to this, the Station concluded at 5:10 at March 13 that the situation corresponded to Article 15 of the Act on Special Law of Emergency Preparedness for Nuclear Disaster. At 9:08 on March 13, the SRV was manually started using an automobile battery, the nuclear reactor pressure was lowered and injection of fresh water containing acid started at around 9:25. After this, as the fresh water supply was exhausted, the workers switched to seawater at 13:12 on March 13.

On one side, the work to prepare the PCV vent line was also in progress at the same time, and both the valves (MO valve and AO valve) of the PCV vent line were opened at 8:41 on March 13. At 9:24 on March 13, the workers noticed that the pressure of the D/W had fallen. After this, the AO valve of the vent line closed due to a reduction in the pressure of the compressed gas cylinder, hence this valve was opened by replacing the cylinder and setting up a temporary compressor. At around 11:01 on March 14, an explosion that was assumed to be a hydrogen explosion occurred at the upper part of the nuclear reactor building and the roof and walls were damaged.

The injection of seawater was temporarily interrupted as the fire engine and hose which were being used for the injection of seawater was damaged by this impact. After this, the hose was drawn out from the pier and the injection of seawater was started again by the fire engine at around 16:30 on March 14.

Unit 4 was undergoing a periodic inspection and all fuel assemblies had been removed from the reactor to the spent fuel pool due to the shroud replacing work. Therefore, fuel with relatively high decay heat for one full core was stored in the SFP. A total of 1,535 pieces of spent fuel assemblies were stored there, which amounted to 97% of its storage capacity of 1,590 pieces. Due to the loss of the external power supply and subsequent loss of AC power supply, the electric motor operated pump and seawater system pump became nonfunctional and the cooling function of the SFP and make-up water function was lost. At 4:08 on March 14, the SFP water temperature rose to 84°C. At around 6:00 on March 15, an explosion that was assumed to be a hydrogen explosion occurred in the reactor building, and it was confirmed that the upper part of the building

collapsed. Furthermore, at 9:38 on March 15, a fire was identified in the northwest part of the third floor of the reactor building.

On March 16, when an SFP inspection was done by the Self-Defense Forces helicopter, they stated that the fuel was not exposed by observing the water surface. Water was injected in the SFP by the Self-Defense Forces on March 20 and by a U.S. armed forces high-pressure water truck on March 21. Moreover, the injection of water was carried out by a concrete pump motor after March 22.

The cause of the hydrogen explosion which occurred in Unit 4 was not clearly identified initially. Later, it was assumed that it must have been because the fuel in the SFP was exposed because of the low water level in the SFP due to evaporation and hence, the water from the nuclear reactor side flowed into the SFP through the pool gateway. Moreover, it could be considered after analyzing of nuclides from the water that there was no damage to the fuel rods and hence, it was thought that the main cause of the hydrogen explosion was not the fuel within the SFP, but one possible reason was the hydrogen gas, which was released by the PCV vent line of Unit 3 and flowed through the exhaust duct.

Unit 5 was undergoing a periodic inspection, and RPV pressure leakage tests were being conducted with fuel loaded in the reactor. There was enough water in the RPV and all the control rods were inserted.

Due to the loss of external power supply and large tsunami after that, the AC power supply was also completely lost, but the flood water was prevented from entering the building because of the DC power supply and the plant could be used. The nuclear reactor pressure rose due to decay heat, but because the SRV (safety valve function) was opened and closed from around 1:40 on March 12, the pressure dropped below the maximum operating pressure. At 6:06 on March 12, the upper vent valve of the RPV was manually opened from the control room and the pressure was lowered below the atmospheric pressure level, in order to carry out an alternative injection of water in the nuclear reactor. At 20:54 on March 13, a temporary cable was laid from Unit 6 to the condense water makeup system (hereafter called "MUWC") and the MUWC pump was started manually. Due to the effect of decay heat, the pressure within the nuclear reactor rose once again. To combat this, the control was recovered for the SRV system, which had been made nonfunctional in order to perform the Leak and Hydrostatic test, and after 5:00 on March 14, the pressure of RPV was lowered intermittently. After 4:30 on March 14, the alternative water injection to the nuclear reactor was started by MUWC and after that the water level of the nuclear reactor was checked by performing water injection intermittently. Moreover, the supply of water to the SFP was started at 9:27. At 1:55 on March 19, a temporary RHR seawater pump was started and after that, the RHR pump was manually started at around 5:00 on March 19, and SFP cooling was started. At 12:25 on March 20, the cooling of nuclear reactor was started by changing the operation mode of the RHR system and it was stopped at 14:30 on March 20.

Unit 6 was undergoing a periodic inspection and the nuclear reactor and was in cold shutdown condition (all control rods (CR) were in an inserted state) with the fuel being loaded.

Due to the loss of external power supply and subsequent large tsunami, two emergency DGs (seawater type) halted and the remaining one emergency DG (air cooled type) could supply electricity via an emergency generating line because the flood water did not enter and the power supply was also available.

At 13:20 on March 13, alternative injection of water to the nuclear reactor was started by manually starting the MUWC pump at 13:01. After that, the injection of water to the nuclear reactor was continued intermittently. Then, water to the SFP was continuously supplied from 14:13 on March 14.

In response to the rise in pressure of the nuclear reactor due to the effect of decay heat, SRV was manually opened from the control room and the reactor pressure was lowered continuously . At 19:07 on March 18, the Station confirmed that the emergency DG seawater pump (6A), which had been flooded by the tsunami, was in good condition and hence the same seawater pump was started and at the emergency DG (6A) which had stopped at 4:22, was started. At 21:26 on March 19, the temporary RHR seawater pump was started and at 22:14 on March 19, the RHR pump was started and the SFP cooling was started. At 18:48 on March 20, the operation mode of RHR system was switched and cooling of nuclear reactor was started and it was stopped at 19:27 on March 20.

#### 2.1.4 Impact of earthquake

On March 11, 2011, an earthquake occurred at 14:46, with the epicenter located off the coast of Miyagi Prefecture

The epicenter depth was 24 km and the moment magnitude was 9.0, the rupture length was 450 km and the rupture width was approximately 150 km (all values estimated). It is believed that it occurred due to the destruction of plate edges because of an accumulation of strain at the plate boundaries. The rupture length increased as multiple epicenters were joined together.

As shown in Figure 2.1-1, the peak acceleration values obtained at the lowest basement of the nuclear reactor buildings at the time of this earthquake exceeded the values specified in one section of the table corresponding to basic earthquake ground motion Ss.

The acceleration time history waveform and response spectrum observed for the basic nuclear reactor Unit 2, is displayed as an example in Figure 2.1-1. In general, the response spectrum exceeds the basic earthquake ground motion similar to what is shown by a specific period in this record.

Due to this earthquake, power supply was taken from the emergency DG, seawater system or IC, RCIC and such like were functioning and the engineered safety functions of the emergency core cooling system (hereafter called "ECCS") (including seawater system) were in good condition till the tsunami arrived. Also, it was confirmed that the normal make-up water system (MUWC) and diesel driven fire protection pump (hereafter called "D/D-FP") of Unit 1 and 3 were operational even after the earthquake.

Based on indications from the country, Tokyo Electric Power Corporation conducted earthquake response analysis which was based on observations related to nuclear reactor buildings, instruments important to earthquake safety and piping system, for Unit 2 and 4 on June 17 and that for Unit 1 and 3 on July 28. It was concluded that all the instruments important to earthquake safety had maintained their safety functionalities before and after the earthquake.

Before the earthquake, the external power supply for Unit 1 and 2 was from Okuma line 1 and line 2 (275 kV) and Okuma line 3 and 4 (275 kV) for Unit 3 and 4 (however, the start-stop equipment of Okuma line 3 was under construction); for Unit 5 and 6, the Yonomori line 1 and 2 (66 kV) was connected to the new Fukushima transformer substation. Other than this, the TEPCO nuclear power line (66 kV) from the north-east Tomioka transformer substation was connected as a spare line to Unit 1.

Due to this earthquake, the circuit breakers in the switchyard of Unit 1 and 2 were damaged; the cables of the TEPCO nuclear line from the north-east power supply also got damaged. One power line connecting to the switchyard of Unit 5 and 6 was also destroyed. As a result, all the external power supply to units 1 to Unit 6 was lost.

Moreover, from a comparison between the peculiar period of steel tower (0.3 to 1 sec) and the earthquake motion acceleration response spectrum (peak response acceleration 2,000 gal) and from the status of destruction, it is assessed that the steel tower was not destroyed due to the earthquake motion but collapsed because the level of the soil fell.

Table 2.1-1 Maximum acceleration from basement of reactor buildings

Observation point (basement of reactor buildings)		Observed data			Maximum response acceleration against basic earthquake ground motion Ss (Gal)		
		Maximum response acceleration (Gal)			North-South Direction	East-West Direction	Vertical Direction
		North-South Direction	East-West Direction	Vertical Direction			
Fukushima Daiichi	Unit 1	460	447	258	487	489	412
	Unit 2	348	550	302	441	438	420
	Unit 3	322	507	231	449	441	429
	Unit 4	281	319	200	447	445	422
	Unit 5	311	548	256	452	452	427
	Unit 6	298	444	244	445	448	415

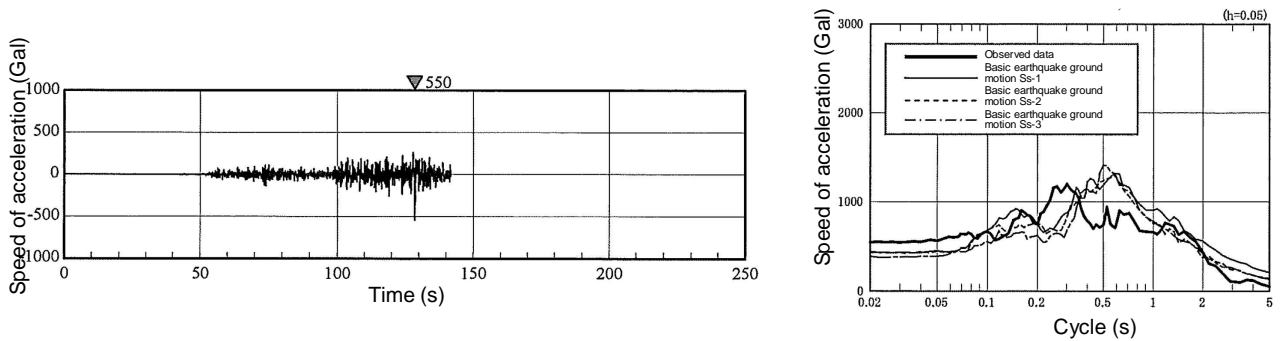

(Note: The recording equipment was interrupted due to the earthquake)

Figure 2.1-1 Ripple figure of instant acceleration history of reactor building and response spectrum (east-west direction)

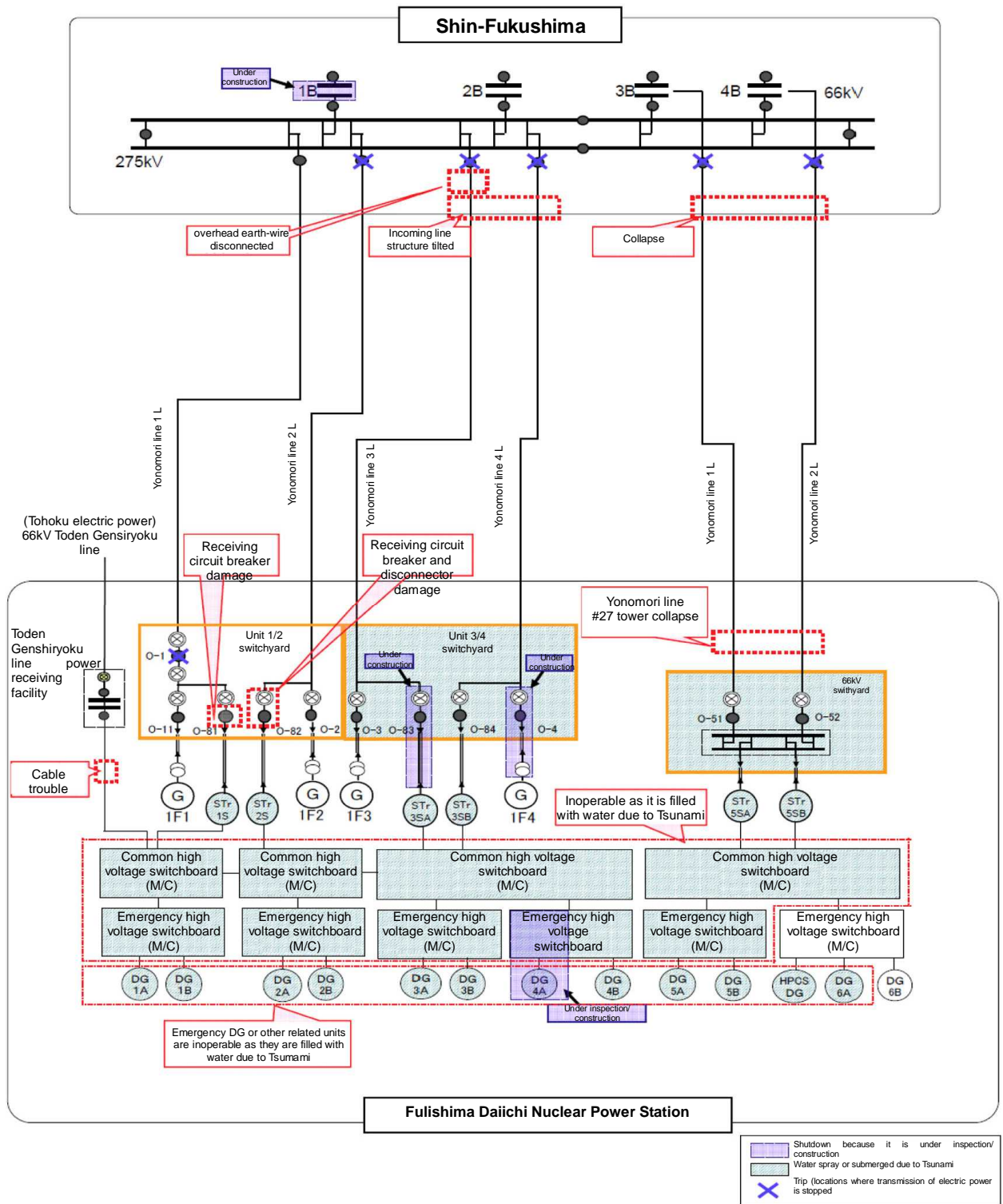

Figure 2.1-2 Outline figure of external power supply control system (after earthquake, before tsunami)

### 2.1.5 Impact of tsunami

Due to the earthquake, at 15:27, the first tsunami came from the ocean which is on the front side of the reactor site and the second tsunami appeared at 15:35. Among these, the second was higher than the reactor height and almost the whole area of the main building of the site was flooded with water.

Based on the tsunami measurement methods of the Society of Construction Engineers, the design as revised in 2002 was for a height of tsunami of about O.P. +5.7 m (Fukushima Daiichi Unit 6). In contrast to this, the height of the tsunami which actually came was, O.P. approximately +11.5 to approximately +15.5 (depth of flood water approximately 1.5 to approximately 5.5.m) from the main building setup area (Fukushima Daiichi 1 to 4 unit side, site height O.P. +10 m) and O.P. approximately +13 to approximately +14.5 m (depth of flood water approximately below 1.5 m) from the main building setup area (Fukushima Daiichi 5 to 6 unit side, site height O.P. +13 m) (without including changes to the ground due to the earthquake).

The height of the tsunami was much larger than the tsunami height measurements that had been made so far, because of the activity of multiple territories which until now used to be thought of as single territory activity and hence a major earthquake of magnitude 9.0 occurred. The length of the dislocation was 400 km and width was 200 km, which was something that had never been seen before, and the slippage of the dislocation was extremely large at more than 20 m, which was something that had never been considered.

It is thought that the surrounding area of the main building, which is on a site of O.P. +10 m and O.P. +13 m, was almost flooded by the tsunami. However, no significant damage was confirmed to the construction of the outer wall or pillars of the main building. However, mainly considering the east side (sea side) of the T/B of Unit 1 to 4, parts of the door or shutter and such like installed at the entrance, were damaged by the tsunami. Parts of the entrance above the ground of the main building (entrance and exit of the main building and the entrance for moving the instruments (hatch), exhaust outlet (louver) or entrance connecting to the trench or ducts laid underground on the site (the penetration entrance for cables or plumbing) came in the path of the flood water inside the building and the flood water flowed through the passages or the stairs and flooded a large underground area.

A large number of emergency DGs and switchboards, which were installed in the basement (height 0 m to 5.8 m) of the reactor building or T/B, were damaged by the tsunami, all the units except Unit 6 lost the emergency electric supply. Out of the three emergency DGs in Unit 6, the DG installed in the reactor building did not stop and could receive an emergency electric power supply. The main DC busbar of units 1, 2, and 4 was under the flood water and that of 3, 5, 6 was not under the flood water. The extent of flooding of the emergency electric supply, emergency diesel power generation device and DC busbar and the impact is described in Table 2.1-2.

All the auxiliary cooling seawater pumps were also flooded by the tsunami. However, except the pumps which had been taken out for inspection, all the pumps were present at the installation location even after tsunami and the pump body was not washed away. Destruction of the crane used for equipment installation, damage to pumps or ancillary equipment when they collided with

flotsam and the mixing of seawater in electric motor bearing lubricating oil was identified.

It seems that the important safety instruments must also have been damaged due to the seawater flood within the reactor building, but because of constraints due to high radiation, investigation was not done. It was confirmed that during this the MUWC pumps of Units 1 to 4 were flooded and even after temporarily recovering the electricity, their functions could not be restored.

Table 2.1-2 Impact on in -power source system in the plant due to flood water of tsunami

	Unit 1-3														
	Unit no. 1					Unit no. 2					Unit no. 3				
	Component	Installation site	Installation floor	Availability for use	Condition	Component	Installation site	Installation floor	Availability for use	Condition	Component	Installation site	Installation floor	Availability for use	Condition
Starting transformer	STr(1S)	Transformer yard	Above ground	Unclear	Immersed in the water	STr(2S)	Transformer yard	Above ground	Unclear	Immersed in the water. Damage to the attachment such as insulator	STr(3SA)	Transformer yard	Above ground	Unclear	Cannot be checked (Note 1)
Cable	OF Cable (Switchyard - STr(1S))	—	Underground	Unclear	Partial appearance is good	OF Cable (Switchyard - STr(2S))	—	Underground	Unclear	Cannot be checked (Note 2)	OF Cable (Switchyard - STr(3SA))	—	Underground	—	Under repair
D/G	DG 1A	T/B	B1FL	×	Submerged	DG 2A	T/B	B1FL	×	Submerged	DG 3A	T/B	B1FL	×	Submerged
	DG 1B	T/B	B1FL	×	Submerged	DG 2B	Shared pool	1FL	×	M/C Submerged Cannot be used	DG 3B	T/B	B1FL	×	Submerged
Emergency high voltage switchboard (M/C)	M/C 1C	T/B	1FL	×	Immersed in the water	M/C 2C	T/B	B1FL	×	Submerged	M/C 3C	T/B	B1FL	×	Submerged
	M/C 1D	T/B	1FL	×	Immersed in the water	M/C 2D	T/B	B1FL	×	Submerged	M/C 3D	T/B	B1FL	×	Submerged
	—	—	—	—	—	M/C 2E	Shared pool	B1FL	×	Submerged	—	—	—	—	—
Regular high voltage switchboard (M/C)	M/C 1A	T/B	1FL	×	Immersed in the water	M/C 2A	T/B	B1FL	×	Submerged	M/C 3A	T/B	B1FL	×	Submerged
	M/C 1B	T/B	1FL	×	Immersed in the water	M/C 2B	T/B	B1FL	×	Submerged	M/C 3B	T/B	B1FL	×	Submerged
	M/C 1S	T/B	1FL	×	Immersed in the water	M/C 2SA M/C 2SA Building	1FL	×	Submerged	M/C 3SA	C/B	B1FL	×	Submerged	
Emergency Power center (P/C)	P/C 1C	C/B	B1FL	×	Submerged	P/C 2C	T/B	1FL	○	Base portion is immersed in the water	P/C 3C	T/B	B1FL	×	Submerged
	P/C 1D	C/B	B1FL	×	Submerged	P/C 2D	T/B	1FL	○	Base portion is immersed	P/C 3D	T/B	B1FL	×	Submerged
	—	—	—	—	—	P/C 2E	Shared pool	B1FL	×	Submerged	—	—	—	—	—
Regular Power center (P/C)	P/C 1A	T/B	1FL	×	Immersed in the water	P/C 2A	T/B	1FL	○	Base portion is immersed in the water	P/C 3A	T/B	B1FL	×	Submerged
	—	—	—	—	—	P/C 2A.1	T/B	B1FL	×	Submerged	—	—	—	—	—
	P/C 1B	T/B	1FL	×	Immersed in the water	P/C 2B	T/B	1FL	○	Base portion is immersed in the water	P/C 3B	T/B	B1FL	×	Submerged
	—	—	—	—	—	—	—	—	—	—	P/C 3SA	C/B	B1FL	×	Submerged
	—	—	—	—	—	—	—	—	—	—	—	—	—	—	—
—	—	—	—	—	P/C 2SB	T/B	B1FL	×	Submerged	P/C 3SB	C/B	B1FL	×	Submerged	
Direct current 125V	125V DC BUS-1A	C/B	B1FL	×	Submerged	125V DC DIST CTR2A	C/B	B1FL	×	Submerged	125V DC Main bus panel 3A	T/B	MB1FL	○	—
	125V DC BUS-1B	C/B	B1FL	×	Submerged	125V DC DIST CTR3A	C/B	B1FL	×	Submerged	125V DC Main bus panel 3B	T/B	MB1FL	○	—

	Unit 4-6														
	Unit no. 4					Unit no. 5					Unit no. 6				
	Component	Installation site	Installation floor	Availability for use	Condition	Component	Installation site	Installation floor	Availability for use	Condition	Component	Installation site	Installation floor	Availability for use	Condition
Starting transformer	STr(3SB)	Transformer yard	Above the ground	Unclear	Cannot be checked (Note 1)	STr(5SA)	Transformer yard	Above the ground	○	—	STr(5SB)	Transformer yard	Above the ground	○	—
Cable	OF Cable (Switchyard - STr(3SB))	—	Underground	Unclear	Cannot be checked (Note 2)	OF Cable (Switchyard - STr(5SA))	—	Underground	○	—	OF Cable (Switchyard - STr(5SB))	—	Underground	○	—
D/G	DG 4A	T/B	B1FL	×	Submerged (Under repair)	DG 5A	T/B	B1FL	×	Associated equipment (Exciter) is submerged	DG 6A	C/S	B1FL	×	Associated equipment (Sea water pump) is submerged
	DG 4B	共用プール	1FL	×	M/C Submerged Cannot be used	DG 5B	T/B	B1FL	×	Associated equipment (Exciter) is submerged	DG 6B	DG建屋	1FL	○	—
	—	—	—	—	—	—	—	—	—	—	HPCS DG	C/S	B1FL	×	Associated equipment (Sea water pump) is immersed
Emergency high voltage switchboard(M/C)	M/C 4C	T/B	B1FL	×	Submerged (Under inspection)	M/C 5C	T/B	B1FL	×	Submerged	M/C 6C	C/S	B2FL	○	—
	M/C 4D	T/B	B1FL	×	Submerged	M/C 5D	T/B	B1FL	×	Submerged	M/C 6D	C/S	B1FL	○	—
	M/C 4E	Shared pool	B1FL	×	Submerged	—	—	—	—	—	HPCS DG M/C	C/S	1FL	○	—
Regular high voltage switchboard (M/C)	M/C 4A	T/B	B1FL	×	Submerged	M/C 5A	C/B	B1FL	×	Submerged	M/C 6A-1	T/B	B1FL	×	Submerged
	M/C 4B	T/B	B1FL	×	Submerged	M/C 5B	C/B	B1FL	×	Submerged	M/C 6A-2	T/B	B1FL	×	Submerged
	—	—	—	—	—	M/C 5SA-1	C/B	B1FL	×	Submerged	M/C 6B-1	T/B	B1FL	×	Submerged
	—	—	—	—	—	M/C 5SA-2	C/B	B1FL	×	Submerged	M/C 6B-2	T/B	B1FL	×	Submerged
	—	—	—	—	—	M/C 5SB-1	C/B	B1FL	×	Submerged	—	—	—	—	—
—	—	—	—	—	M/C 5SB-2	C/B	B1FL	×	Submerged	—	—	—	—	—	
Emergency Power center (P/C)	P/C 4C	T/B	1FL	—	Under repair	P/C 5C	T/B	B1FL	×	Immersed in the water	P/C 6C	C/S	B2FL	○	—
	P/C 4D	T/B	1FL	○	—	P/C 5D	T/B	B1FL	×	Immersed in the water	P/C 6D	C/S	B1FL	○	—
	P/C 4E	Shared pool	B1FL	×	Submerged	—	—	—	—	—	P/C 6E	DG Building	B1FL	○	—
Regular Power center (P/C)	P/C 4A	T/B	1FL	—	Under repair	P/C 5A	C/B	B1FL	×	Immersed in the water	P/C 6A-1	T/B	B1FL	×	Immersed in the water
	—	—	—	—	—	P/C 5A-1	T/B	2FL	○	—	P/C 6A-2	T/B	B1FL	×	Immersed in the water
	P/C 4B	T/B	1FL	○	—	P/C 5B	C/B	B1FL	×	Immersed in the water	P/C 6B-1	T/B	B1FL	×	Immersed in the water
	—	—	—	—	—	P/C 5B-1	T/B	2FL	○	—	P/C 6B-2	T/B	B1FL	×	Immersed in the water
	—	—	—	—	—	P/C 5SA	C/B	B1FL	×	Immersed in the water	—	—	—	—	—
—	—	—	—	—	P/C 5SA-1	T/B	B1FL	×	Immersed in the water	—	—	—	—	—	
—	—	—	—	—	P/C 5SB	C/B	B1FL	×	Immersed in the water	—	—	—	—	—	
Direct current 125V	125V DC Main bus panel 4A	C/B	B1FL	×	Submerged	125V DC Main bus panel 5A	T/B	MB1FL	○	—	125V DC PLANT DISTR CTR2A	T/B	MB1FL	○	—
	125V DC Main bus panel 4B	C/B	B1FL	×	Submerged	125V DC Main bus panel 5B	T/B	MB1FL	○	—	125V DC PLANT DISTR CTR3A	T/B	MB1FL	○	—

Availability for use of the equipment on the spot  
 Judgment of employees of Tokyo Electric Power Company after checking the condition of the equipment on the spot  
 Condition with the traces of immersion  
 Water is accumulated  
 Component that cannot be used  
 M/C at the last dispatching source cannot be used, so electricity cannot be received

T/B : Turbine building  
 C/B : Control building  
 : Reactor combination building

Note 1 : Since the radiation dose is high  
 Note 2 : As submerging of installation site is assumed

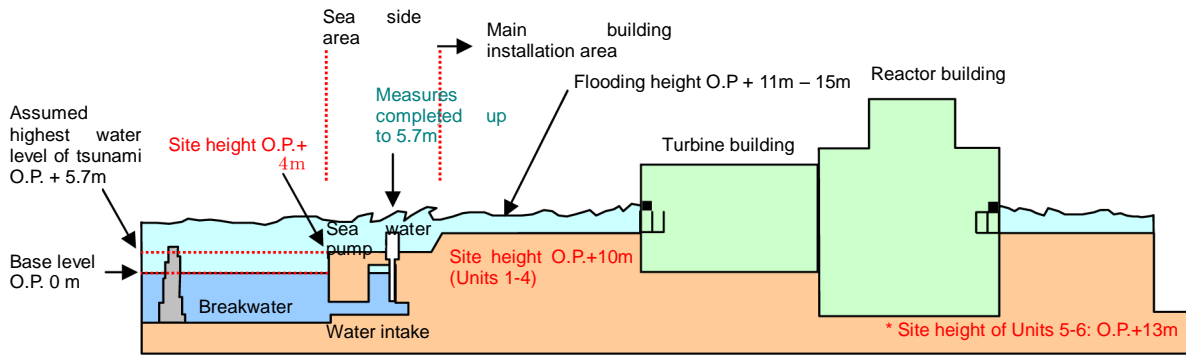

Figure 2.1-3 Situation of tsunami

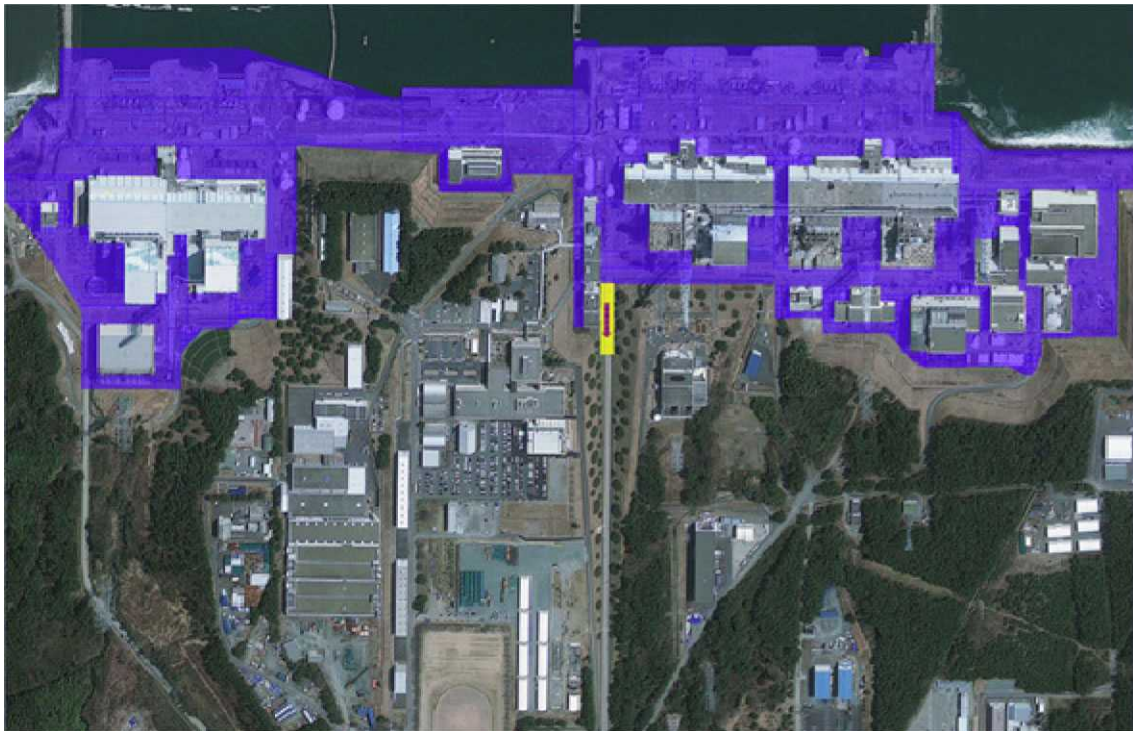

Figure 2.1-4 Extent of flooding within the power plant

## 2.2 Course of accident at Unit 1

### 2.2.1 Conditions from earthquake to arrival of tsunami

While Unit 1 was operating at a fixed rated electric output (460 MWe), it automatically stopped in response to the signal [Peak Earthquake Acceleration] which was due to the Great East Japan Earthquake which occurred at 14:46 on March 11, 2011 and all the control rods (CR) were inserted.

Due to the impact of the earthquake, the circuit breaker of Okuma line 1L, 2L was damaged and hence the outside power supply was completely lost and electricity from the emergency busbar was also lost. Hence, immediately two emergency DGs (1A, 1B) started automatically and electricity to the emergency busbar was recovered.

At 14:47 on March 11, due to the loss of electricity to the emergency busbar, the electricity was lost for the reactor protection system and hence, MSIV was shutdown automatically by a fail -safe system. The nuclear reactor pressure rose due to the MSIC shutdown and at 14:52 on March 11, the 2 ICs started automatically in response to the signal [Reactor Pressure High (7.13 MPa [gage])]. The reduction of pressure and cooling of nuclear reactor was started and the nuclear reactor pressure suddenly started declining.

The nuclear reactor water level became very low for a moment, due to a smashing of a void immediately after the automatic shutdown of nuclear reactor; however, the feed water to the nuclear reactor continued till the nuclear reactor feed water pump was tripped after the loss of external electricity. The water level did not reach a low level when the HPCI started automatically and was restored and changed to an almost normal water level.

The workers concluded that the decrease in nuclear reactor pressure that occurred when the IC started was fast and the rate of decrease in temperature of the nuclear reactor cooling material was not observed to be 55°C/h, as decided by the operation manual. Hence, at 15:03, March 11, for regulating of nuclear reactor pressure, 2 IC devices were manually stopped (IC piping isolation reverse valve MO-3A,3B [close] operation). Thereafter, startup and shutdown of IC series 1 (A) started (IC piping isolation reverse valve MO-3A [start], [close] operation) was repeated and nuclear reactor pressure was regulated to approximately 6 to 7 MPa [gage].

On one side, MSIV stopped automatically; hence, in order to execute cooling of S/C, the workers manually started the containment cooling system (hereafter called "CCS") and thus started cooling the S/C from 15:07 to 15:10 on March 11.

As mentioned above, the normal loss of external power supply meant that support after scram operation of reactor was carried out during the time from the occurrence of the earthquake to the arrival of the tsunami.

## **2.2.2 Situation of nuclear reactor building from tsunami to hydrogen explosion**

On March 11, approximately 51 minutes after the earthquake, at 15:37, due to the tsunami, power connection to the seawater cooling pump flooded. As a result of it being submerged, the two emergency DGs stopped and resulted in a complete power loss. As a result, the Station decided that the situation corresponded to Special Law for Nuclear Emergency Article 10 (Complete loss of AC power supply).

Accompanying this Complete Loss of AC Power supply, while the MCR illumination, signal light had gone out gradually, a warning sound also ceased. The illumination of Unit 1 was emergency lights only. Unit 2 was in complete darkness.

The equipment operating on DC power supply were IC and HPCI. But after examining the situation, the workers were unsure whether the IC had an open or closed valve and the HPCI also had its indicator lit up and did not start and was turned off on the control panel.

As the power supply of the instrument had been lost, the reactor water level had been uncertain since 15:30 on March 11. At 16:36 on March 11, as the flood water situation in the reactor was unknown, the Station decided that the situation corresponded to Article 15 of the Act on Special Law of Emergency Preparedness for Nuclear Disaster (Non-emergency core cooling system priming). After that, at 16:45 on March 11, the situation recovered from the Special Law for Nuclear Emergency Article 15 as the reactor water was restored, but at 17:07 on March 11 the Station decided that the situation corresponded to Article 15 of the Act on Special Law of Emergency Preparedness for Nuclear Disaster as the reactor water level was unknown.

At 17:12 on March 11, to securely inject water to the reactor, the power plant manager (Power Station Emergency Division) instructed the workers to investigate the extinguish fire system (hereafter called "FP"), MUWC, CCS and alternate injection at a fire engine as one of the accident management measures.

Then, simultaneously with the alternate injection, an open process investigation started at the containment (called "PCV") vent because there was no power.

The support status of PCV vent and alternate injection is separately described below.

### Support status of alternative injection

At Headquarters of Power plant emergency response (hereafter called "headquarters for the power plant"), it was decided to use D/D-FP, instead of FP line using core spray system (hereafter called "CS") as an alternative to alternate injection. At 17:30 on March 11 D/D-FP was started.

Due to the loss of power on valve operation of the alternate injection line, the tasks to be performed during the operation could not be performed. Because of this, the nuclear reactor building (hereafter called "R/B") was in total darkness, and the CS and other valves were opened manually. As there was a possibility

that the reactor had been flooded after depressuring (below 0.69 MPag), time was required to perform difficult tasks.

The power plant restoration team from the headquarters investigated the degree to which the power panel (high voltage power supply board and power center) had been submerged and damaged, and applied insulation resistance material. The power panel of Unit 1 was found to be out of service, one part (P/C-2C, P/C-2D) of the power center of the adjoining Unit 2 was confirmed to be available. Hence, workers investigated the possibility of restoring power by using the Unit 2 power center so as to make it possible to use the high pressure injection system (hereinafter called SLC).

At 17:00 on March 11, electricity distribution Tokyo head office instructed all its branches to secure high and low voltage power cars and confirm the routing to Fukushima Daiichi and requested Tohoku Electric Power to dispatch a high voltage power supply vehicle. Although power supply cars of all bases headed toward Fukushima, due to the damaged roads and congestion they were not advancing as expected. Apart from that, air transport of power supply vehicles from the self-defense force, and the US armed forces was investigated but the idea was abandoned as the vehicles were too heavy.

As the temporary DC power supply system to the IC was restored, the supply line isolation valve of IC (A system) MO-2A and return piping isolation valve MO-3A was indicated as being in closed by the indicator lamp. Hence at 18:18 on March 11, the MO-2A valve and MO-3A valve of IC (A system) were opened and it was confirmed that steam was coming out from the IC system vent pipe (condenser steam emission pipe). After that, at 18:25 the piping isolation valve MO-3A was closed.

Meanwhile, the condition of 4 isolation valves (MO-1A, MO-1B, MO-4A, MO-4B) between IC (B System) and PCV was uncertain as the electric power to the display lamp had been lost.

In the central operating room, due to the loss of electrical power, the indicated value of the monitoring instruments was unclear, and so the worker entered the reactor building (R/B), which was in total darkness, to examine the pressure gauge. As a result, at 20:07 on March 11, on the atomic pressure gauge the pressure was found to be 6.9 MPa [gage].

To restore the lighting and monitoring instruments in the central operating room, the headquarters of the power plant restoration team accumulated the necessary batteries and cables. On At 20:49 on March 11, temporary lighting was used in the central operating room using a small generator. Also by connecting a temporary battery to the monitoring instrument, it was identified that the nuclear reactor water level (fuel range) was +200 mm from TAF on the meter. (Note)

It was confirmed that steam was in the IC vent pipe once again at 21:30 on March 11 after opening the return line Isolation valve MO-3A. After that, as the radiation dose was raised in the R/B, at 21:51 on March 11 entering in the R/B was banned. At 22:00 on March 11, an alarm pocket dosimeter (hereafter called "APD") in the R/B showed 0.8 mSv after a short time and that radiation dose at the site had increased was reported to the headquarters of the power plant.

Again at 23:00 on March 11 radiation doses on the north side double door of T/B1 floor (R/B entrance) were 1.2 mSv/h, and 0.5 mSv/h on the south side double door.

At 01:48 on March 12, it was found that D/D-FP, which was in operational status for nuclear reactor injection, had stopped, so battery exchange, refuel and such like were carried out for restoration, but it was not possible to start D/D-FP. Because of that, the workers investigated using a fire engine and tying up a water hose for injection. Along with spraying the water from a hydrant, using the filtered water tank as a source was not found to be possible, hence the Station decided to search for a water source in the earth and use fire extinguisher tanks.

Out of 3 fire tanks at the power plant, one had been damaged by the tsunami, one was deployed at units 5 and 6 and was difficult to remove due to road damage and rubble from the tsunami. The management planned to deploy the remaining one at Fukushima Daiichi but due to the rubble from the tsunami, a quite bit of time was spent for moving the unit.

On one side, the nuclear reactor at around 2:45 on March 12 was found to have a reactor pressure that had declined to 0.8 MPa [gage]. At around 3:45 on March 12, when the double door of R/B was opened for radiation measurement, a white haze was seen and hence the doors were rapidly closed and the workers abandoned the idea of measuring the radiation.

At around 4:30 on March 12, an aftershock occurred and a tsunami warning was issued. As a result, the headquarters of the power plant ordered to stop fieldwork.

The fire engine pump house connection to Fukushima Daiichi FP line water output gate was completed. As a result, from 5:46 on March 12 fresh water injection from a fire tank to the nuclear reactor was started.

At around 5:52 on March 12, the injection volume from the fire engine became 1,000 liters, and after that, at around 9:15 on March 12, the fresh water injection was 6,000 liters, and on the same day by 9:40 it was 21,000 liters.

Moreover, further arranged fire engines arrived and it became possible to transfer fresh water from the fire tank at Unit 3 to that at Unit 1. However, only one hose could be connected to the fire tank, so the fresh water supply to the reactor needed to be discontinued.

Thus, by March 12 at 14:53, a total of 80,000 liters of fresh water had been injected.

Due to the limitations of the fire tank fresh water, concurrent with the fresh water infusion, seawater infusion was arranged. On March 12 at 14:54 the power director ordered the infusion of seawater in the reactor. From the situation at the site, the water source of seawater had been deemed to have flowed back to the unit 3 backlash valve. To ensure lightweight, a 3 fire engines was connected in series to Unit 3 and an injection line for the reactor was configured.

Alternately using a fire pump engine and concurrent infusion, the SLC power restoration also advanced. High voltage power supply cars and the Unit 2 power

center, which was not impacted by the tsunami, were used and a cable was connected to the low voltage power supply board of Unit 1. Thus, at around 15:30 on March 12 the SLC power supply was restored and SLC injection preparation was completed

Note: In the Instrument display, water level at the core is shown as ensured level but considering damage to the core and such like there was a possibility that the display of the instrument was inaccurate.

#### Support status at PCV Vent

On March 11 in the evening, the workers progressed to study the operating procedure of the PCV vent line valve in a situation where there was no power. They found that in a small valve of the S/C vent valve (AO valve), there was a small handle for manual operation so the workers confirmed that manual opening operation is possible and they continued preparing to conduct PCV vent.

On top of the lack of power supply to instruments due to the tsunami, the D/W pressure also was uncertain. On March 11 at 23:50, when operating a small generator that had been set up for temporary lighting in the central operating room used to supply power to the D/W pressure gauge, after comparing the indicated value the workers found it to be 600 kPa [abs], the maximum allowed pressure for D/W was 528 kPa [abs] (427 kPa [gage]). Thus, they found it to be excessive during temporary lighting operation using a small generator. Hence, at 0:06 on March 12, the plant manager ordered workers to prepare for the PCV ventilation, and they went on to confirm the concrete operation method and procedure for PCV ventilation line valves.

At 0:30 on March 11, complete evacuation of the residents in a 3 km radius occurred. (1:45 Reconfirmation & Implementation.)

At 0:49 on March 12, as there was a chance that the D/W pressure would go beyond 600kPa [abs], the Station decided that the situation corresponded to Article 15 of the Act on Special Law of Emergency Preparedness for Nuclear Disaster (abnormal increase in the containment vessel pressure).

At 1:30 on March 12, the Plant applied to TEPCO regarding PCV vent implementation at Unit 1 and 2, and also obtained the consent of the Prime Minister, Minister of Economy and Nuclear Safety and NISA. (Note: Later, after understanding that the reactor core isolation cooling system of Unit 2 was working, the PCV vent of Unit 1 was implemented as a priority.)

At 2:24 on March 12, the working hours and exposure dose of PCV vent field operations was evaluated. In the case of an atmospheric dose of 300 mSv/h, the emergency dose limit (100 mSv/h), possible working hours are 17 minutes. In the case of self-air set equipment, the time is 20 minutes. So the Station evaluated that workers must receive iodine doses.

At 2:30 on March 12, the D/W pressure increased to 840 kPa [abs]

At 3:06 on March 12, a press release was issued about the PCV vent implementation.

At 3:45 on March 12, the Station reported to the TEPCO headquarters about the exposure and results of dose assessment around the power plant during PCV vent.

At 4:45 on March 12, the APD which was set to 100 mSv and front masks arrived at the central operating room from the headquarters of the power plant.

At 4:50 on March 12, pollution was seen on the workers returning from the seismic isolation building. Thus, while entering the site from the seismic isolation building equipment [front mask, charcoal filter, B equipment, C equipment or Cover All] were set.

At 4:55 on March 12, the radiation dose in the power plant increased. (Near the main entrance, it went from 0.069 $\mu$ Sv/h at 4:00 to 0.59  $\mu$ Sv/h at 4:23.)

At around 5:00 on March 12, workers were instructed to use (front mask and charcoal filter and B equipment) even in the central operating room. As the radiation dose toward the Unit 1 side rose in the central operating room, workers were evacuated to the low radiation dose side of Unit 2 by the shift supervisor.

As the radiation dose in the power plant was rising and the D/W pressure was falling, the Station concluded that the power plant had leaked radioactive material at 5:14 on March 12.

At 5:44 on March 12, the Prime Minister announced that residents staying within a 10 km of radius of Fukushima Daiichi must evacuate.

At 6:50 on March 12, the Ministry of Economy sent instructions for a PCV vent based on regulations for nuclear power plants.

In this context, at 7:11 on March 12, the Prime Minister visited Fukushima Daiichi for inspection and left for Tokyo at 8:40.

At 8:03 on March 12, the power plant manager ordered PCV vent to be performed at 09:00 and prepared a three -member team system with a shift supervisor and 2 deputy of duty class workers.

At 8:27 on March 12, the Station understood that the evacuation of some residents of Okuma City had not been completed. Hence on March 12 at 8:37, they told Fukushima that the PCV vent was going to be started at 9:00, and adjusted the PCV vent implementation so that it would be conducted after Okuma City residents had evacuated.

At 9:03 on March 12, it was confirmed that the residents of Okuma City (Kumachi-ku) had evacuated. An official announcement of PCV vent implementation was made to Fukushima at 9:05.

At 9:04 on March 12, out of 2 valves in the PCV vent line series, initially to open the MO valve, Team 1 (2 members) went to the site. At 9:15 the MO valve was opened about 25% manually as per the procedure.

Subsequently, at 9:24 on March 12, Team 2 (2 members) headed to the torus chamber of the site to manually open the remaining AO valve (small valve) at the vent line by S/C. But because of a high radiation dose and there was a possibility that a dose limit exceeded 100 mSv, they abandoned the operation and returned to the central operating room. Team 3 (2 members) also abandoned the operation due to the high radiation dose.

As it was not possible to open the AO valve at vent line from the site by S/C, the power plant headquarters began to look into the feasibility of connecting a temporary air compressor to the stopped air in the instrument (hereafter called "IA"). And expecting residual pressure in the IA system, the AO valve (small valve) in the vent line was opened from the central operating room.

On March 12 at 10:17, in the central operating room, the first opening operation was done by S/C on the AO valve (small valve) on the vent line. In connection with this, on March 12 at 10:23 (2<sup>nd</sup> time) and 10:24 (3<sup>rd</sup> time) the same AO valve opening operation was done. Note: Confirmation could not be obtained whether the AO valve was opened or not for the 3<sup>rd</sup> time.

On March 12 at 10:40, the radiation dose of the main gate and monitoring post (hereafter called "MP"), was measured and the radiation doses were found to have gone up temporarily. On March 12 at 11:15 the radiation dose decreased, so it was assumed that there was a possibility that the PCV vent valve had not been open sufficiently.

For that reason, to open the AO valve (large valve), on March 12 from 12:30 onwards the workers continued to prepare a temporary air compressor, and outside the R/B big equipment hatch, a temporary air compressor was installed and connected to IA piping connected.

On March 12 from around 14:00 onwards, the IA piping was pressurized, and D/W pressure decreased from 0.75 MPa to 0.58 MPa (at 14:50).

Hence, at 14:30 on March 12, the Station concluded that there had been a release of radioactive material from the PCV ventilation.

### **2.2.3 Condition of nuclear reactor building after hydrogen explosion**

At 15:30 on March 12, the SLC temporary power had been restored and the SLC injection preparation had been completed, immediately after that, a hydrogen explosion occurred at the nuclear reactor building at 15:36. After this explosion, evacuation from the site was implemented, the injured, 3 TEPCO employees and 2 collaborator company employees, were rescued and transported. Seawater injection and SLC injection related preparation work was interrupted till the condition of the site and safety were confirmed.

The dose was measured (1,015  $\mu$ Sv/h) at the MP of the power plant site boundary, which exceeded 500  $\mu$ Sv/h. So, on March 12 at 16:27 the Station decided the situation corresponded to Article 15 of the Act on Special Law of Emergency Preparedness for Nuclear Disaster (abnormal increase in radiation dose within the power plant site boundary).

At 18:05 on March 12 the Minister of Economy ordered the workers to fill the RPV with seawater in accordance with the regulations on nuclear power plants. This was instructed by the main branch to the power plant.

At around 18:30 on March 12, after a site examination, in a condition where a great deal of rubble covered the area, a cable, which was constructed as a temporary power supply for the SLC, and a hose to inject seawater were damaged and found impossible to use. High pressure power supply vehicles were stopped. Fire engine windows were cracked but not functionally damaged.

Close to Unit 1, high radiation dose rubble was scattered. Hence, under radiation control employee's monitoring, pieces of rubble were cleaned up, hoses for relaying were gathered from outdoor fire dehydrant, and once again seawater injection was prepared.

At around 19:04 on March 12, the workers started to inject seawater into the nuclear reactor using the Unit 3 backlash valve pit as the source, and using an FP line. Moreover, on March 12 at 20:45 the workers began injecting seawater mixed with borate into the nuclear reactor.

#### **2.2.4 Main events after accident**

Regarding to restoration of power supply, on March 15, TEPCO completed testing and inspecting access to electricity from the nuclear power lines. On March 20, the power center was powered and an external power supply was ensured. Then from March 23, the necessary load cables were constructed, started to connect from the power center.

Regarding to alternative injection, on March 25, water injection was stopped and fresh water injection using a deionized water tank as the source was resumed. From March 29, water was injected by using a temporary pump. Furthermore, from April 3, electric power for this pump was changed to the original power supply.

#### **2.2.5 Status of spent fuel pool**

On March 11, 292 spent fuel rods and 100 new fuel rods were stored at Unit 1 SFP.

At 14:46, external power supply was lost in the north-eastern pacific coast of Japan, and a fuel pool cooling purification valve system (hereafter called "FPC") also stopped. Moreover, SFP cooling was possible by using the reactor shutdown cooling system (hereafter called "SHC").

Afterwards, due to the tsunami impact, all AC power supply was lost and SFP cooling functionality and make up water system functionality were lost.

The decay heat of the Unit 1 SFP fuel was evaluated as being approximately 0.18 MWt (on March 11), which was the lowest of all units in Fukushima Daiichi. From March 31 onwards, using a concrete pump vehicle, fresh water injection was started.

Table 2.2-1 Timeline of important events (Unit 1)

March 11, 2011 (Friday)

- 14:46 Great East Japan Earthquake struck. Automatic reactor scram. Official announcement of level 3 emergency conditions.
- 14:47 Automatic shutdown of main turbine, automatic startup of emergency DG.
- 14:52 Automatic start of IC.
- 15:02 Reactor subcritical confirmation.
- Around 15:03 In order to control the nuclear reactor pressure by IC, manual shutdown. Then, the nuclear reactor pressure control was started by IC.
- 15:06 Set up emergency disaster countermeasure headquarters in head office (to understand the damage caused by the earthquake, power failure recovery etc.)
- 15:27 Arrival of first tsunami.
- 15:35 Arrival of second tsunami.
- 15:37 Complete AC power loss.
- 15:42 The Station concluded that a specific situation (complete loss of AC power supply), which corresponds to the Act on Special Law of Emergency Preparedness for Nuclear Disaster had occurred and reported to the government authorities.
- 15:42 Official announcement of first emergency organization. Setup of emergency countermeasures headquarters. (Becomes a joint headquarters with emergency disaster countermeasure headquarters.)
- 16:36 Without confirming the water level in the nuclear reactor, the status of injection of water was unclear, and management concluded that the situation corresponded to specific conditions based on Paragraph 1 of Article 15 of the Act on Special Law of Emergency Preparedness for Nuclear Disaster (Emergency core cooling system (ECCS) water injection not possible) and reported to the government authorities at 16:45.
- 16:36 Official announcement of emergency level 2 conditions
- 16:45 As the workers could confirm the nuclear reactor water level, the Station concluded that a specific situation (Emergency core cooling system (ECCS) water injection not possible), based on the provisions of Paragraph 1 of Article 15 of the Act on Special Law of Emergency Preparedness for Nuclear Disaster had come to an end and reported

to the government authorities at 16:55.

- 17:07 Again, the workers could not confirm the nuclear reactor water level and hence, the Station concluded that the situation corresponded to specific conditions based on Paragraph 1 of Article 15 of the Act on Special Law of Emergency Preparedness for Nuclear Disaster (Emergency core cooling system (ECCS) water injection not possible) and reported to the government authorities at 17:12.
- 17:12 The power plant manager ordered workers to start investigating a method of injecting water into the nuclear reactor using fire engines and an FP line, which was established as a countermeasure for severe accidents.
- 17:30 Start D/D-FP (standby condition)
- 18:18 Reverse piping isolation valve (MO-3A) and supply piping isolation valve (MO-2A) of IC opened, Confirmation that steam was generated.
- 18:25 Reverse piping isolation valve (MO-3A) of IC closed.
- 20:49 Temporary illumination inside MCR.
- 20:50 Evacuation instruction for the citizens of Fukushima Prefecture within a radius of 2 km from Fukushima Daiichi.
- 21:19 Water level of nuclear reactor became clear, TAF +200 mm (see note).
- 21:23 Prime Minister instructed people within a radius of 3 km from Fukushima Daiichi reactor to evacuate, and those within a radius of 3 km to 10 km from the reactor to stay indoors.
- 21:30 Start operation to open the reverse piping isolation valve (MO-3A) of IC, Confirmation of steam generation.
- 21:51 As the radiation level in the nuclear reactor building rose, persons were prohibited from going inside the reactor building.
- 22:00 Confirmation that the water level of the nuclear reactor was TAF +550 mm, communicated to the government authorities and such like at 22:20.
- 23:00 Results of a survey showed that the radiation level inside T/B (T/B 1<sup>st</sup> floor north side before the double door 1.2mSv/h, T/B 1<sup>st</sup> floor south side before the double door 0.5 mSv/h) had increased and this was reported to the government authorities at 23:40.
- March 12, 2011 (Saturday)
- 0:06 Due to a possibility that the D/W pressure had exceeded 600 KPa, the plant manager ordered the main power plant to continue preparations, considering the possibility that containment venting would be

executed.

- 0:30 Confirmation that the national evacuees had taken shelter (confirmation that the citizens within a 3 km radius of Futaba City and Okuma City had taken shelter, checked again at 1:45).
- 0:49 Since there was a possibility that the D/W pressure exceeded 600 kPa abs, the Station concluded that a specific situation (abnormal rise in storage container pressure) corresponding to the provisions of Paragraph 1 of Article 15 of the Act on Special Law of Emergency Preparedness for Nuclear Disaster had arisen and reported to the government authorities at 0:55.
- Around 1:30 Obtained consent from and reported to the Prime Minister, Minister of Economy, Trade and Industry and the Nuclear and Industrial Safety Agency (NISA) about implementing venting of containment of Unit 1 and Unit 2.
- 1:48 Confirmed the shutdown of D/D-FP due to improper conditions. Started investigating whether there was proper connection from the fire engine to the water outlet of the FP line.
- 2:47 At 2:30, management told the government authorities that D/W pressure reached 840 kPa abs.
- 3:06 Conducted a press interview related to the enforcement of storage container vent.
- 4:01 Told the government authorities the results of radiation exposure evaluation assuming the storage container would be vented.
- 4:55 Confirmed increase in the radiation level (main entrance vicinity went from 0.069  $\mu\text{Sv/h}$  (at 4:00) to 0.59  $\mu\text{Sv/h}$  (at 4:23)) inside the power plant and reported to the government authorities.
- 5:14 Due to increase in the radiation level inside the power plant and reduction in D/W pressure, management judged that a leakage of radioactive material to the outside had taken place and reported to the government authorities.
- 5:44 The Prime Minister instructed the people living within a 10 km radius from Fukushima Daiichi to evacuate.
- 5:46 Started fresh water injection in nuclear reactor from the FB line using a fire engine.
- 5:52 Completed injecting 1,000 liters of fresh water using a fire engine from the FP line.
- 6:30 Completed injecting 2,000 liters (total) of fresh water using a fire engine from the FP line.

- 6:33 Confirmed the evacuation status of the region, and found that the authorities are considering transferring the evacuees of Okuma City to the capital.
- 6:50 Enforcement order based on the laws and ordinances issued by the Minister of Economy, Trade and Industry for venting (manual venting).
- 7:11 Prime Minister arrived at Fukushima Daiichi.
- 7:55 Completed injecting 3,000 liters (total) of fresh water using a fire engine from the FP line.
- 8:03 The plant manager instructed to carry out the vent operation till 9:00.
- 8:04 Prime Minister departed from Fukushima Daiichi.
- 8:15 Completed injecting 4,000 liters (total) of fresh water using a fire engine from the FP line.
- 8:27 Confirmed that part of Okuma City had not been evacuated.
- 8:30 Completed injecting 5,000 liters (total) of fresh water using a fire engine from the FP line.
- 8:37 Informed Fukushima Prefecture that workers were preparing to conduct venting operation at around 9:00. Management decided that the venting should be started after residents had evacuated.
- 9:03 Confirmed that evacuation of Okuma district was complete.
- 9:04 The person on duty went to the actual site to carry out the venting operation.
- 9:05 Issued a press announcement on the venting.
- 9:15 Completed injecting 6,000 liters (total) of fresh water using a fire engine from the FP line.
- Around 9:15 Manually opened the storage container (hereafter called "PCV") vent valve (MO valve).
- Around 9:30 Tested operation on the site of S/C vent valve (AO valve) small valve but abandoned testing due to high radiation levels.
- 9:40 Completed injecting 21,000 liters (total) of fresh water using a fire engine from the FP line.
- 9:53 Told the government authorities the results of radiation exposure evaluation assuming that the storage container would be vented.

- 10:17 Opened the S/C vent valve (AO valve) small valve of MCR (expected remaining pressure of pressurized instrumentation air system).
- 10:40 Confirmed that the radiation level of the main gate and MP had increased, so management judged there was a high possibility that radioactive material had been released during the venting.
- 11:15 Due to a reduction in the radiation level, management confirmed the possibility that venting had insufficient effects.
- 11:39 Told the government authorities that one employee of Tokyo Electric Power Corporation, who had gone inside the nuclear reactor for the vent operation, had been exposed to a radiation level of more than 100 mSv (106.30 mSv).
- 14:30 To activate the S/C vent valve (AO valve) and large valve, a temporary air compressor was setup at around 14:00. Management confirmed that the D/W pressure was reduced and made a judgment that the radioactive material was released due to venting, and reported to the government authorities and such like at 15:18.
- 14:53 Completed injecting 80 tons (total) of fresh water using a fire engine from the FP line.
- 14:54 The plant manager instructed the main power plant to start injecting seawater.
- 15:18 The restoring work of SLC was in progress, immediately after the completion of preparations, the SLC pump was to be started and injection of water into nuclear reactor was to be scheduled. Also, management reported information to the government authorities that as soon as they completed preparations, they plan to inject seawater into the nuclear reactor from the FP.
- 15:36 Power was restored using a power source vehicle, and arrangements for injecting water into the nuclear reactor using an SLC were completed.
- 15:36 Explosion occurred in the reactor building. The hose, which had been set up to inject seawater, and the electric supply system for SLC were damaged, and became unusable.
- 16:27 MP measured the radiation level as exceeding 500 $\mu$ Sv/h (1,015 $\mu$ Sv/h). Hence the Station concluded that a specific condition (abnormal increase in radiation dose within the site boundary) had occurred based on Paragraph 1 of Article 15 of the Act on Special Law of Emergency Preparedness for Nuclear Disaster and reported to the government authorities.

- Around 17:20 Departed to survey the situation of the fire engines and reactor building
- 18:05 Headquarters and power plant told there was an order from the Minister of Economy, Trade and Industry based on laws and ordinances.
- 18:25 The Prime Minister instructed the people living within a 20 km radius of the Fukushima Daiichi to evacuate.
- Around 18:30 The results of analyzing the condition of the fire engine, reactor building and such like showed that the hose that had been set up for seawater injection and power supply device of SLC had been damaged and hence were unusable.
- 19:04 Started injecting seawater using a fire engine from the FP line.
- 20:45 Started injecting seawater mixed with boric acid into the nuclear reactor.

Note: The meter indication showed that the water level of the reactor core was being maintained, but thinking about the period of reactor damage and such like, it was possible that the meter was not showing a proper indicated value.

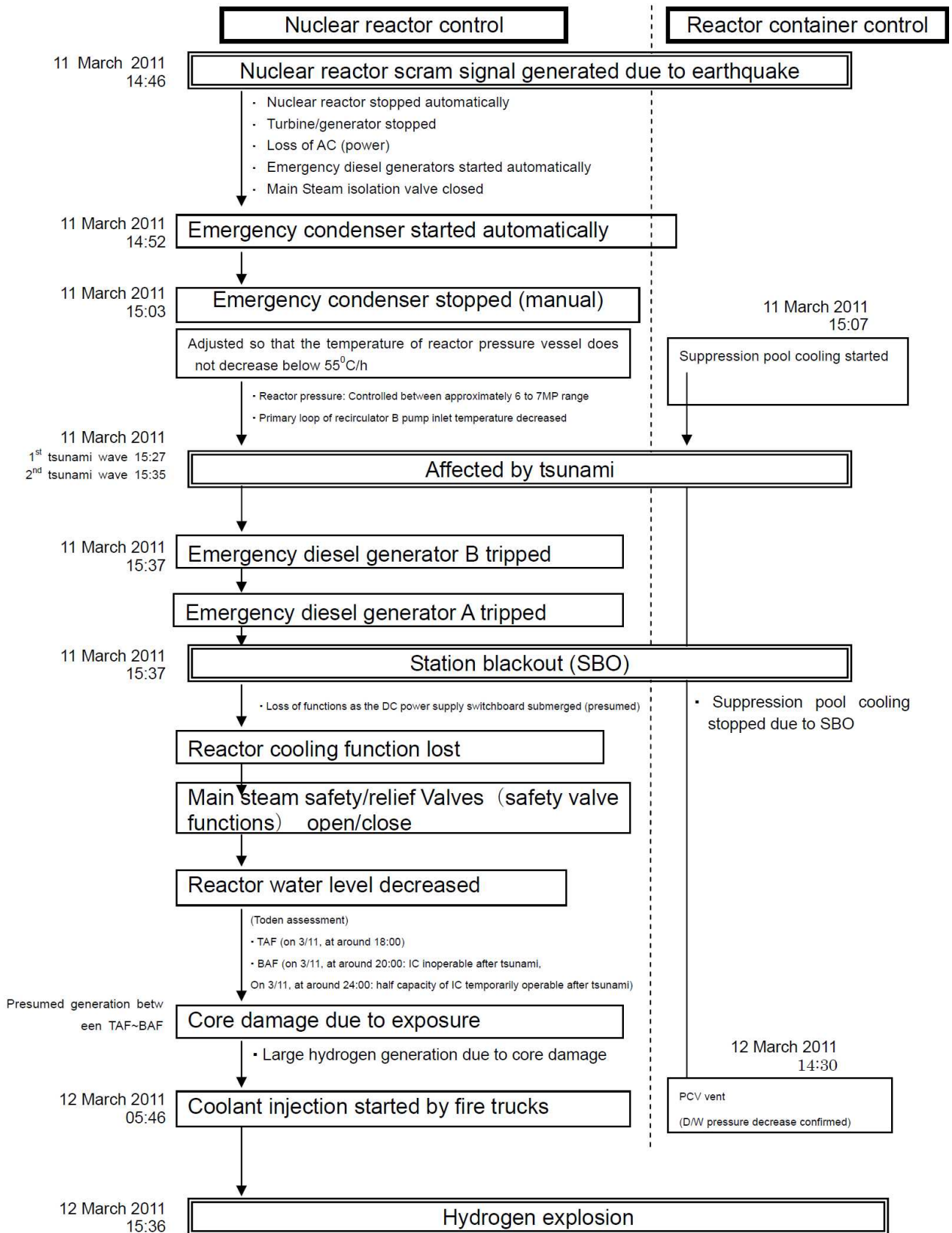

**Figure 2.2-1 Course of accident after earthquake at Unit 1 of the Fukushima Daiichi Nuclear Power Station**

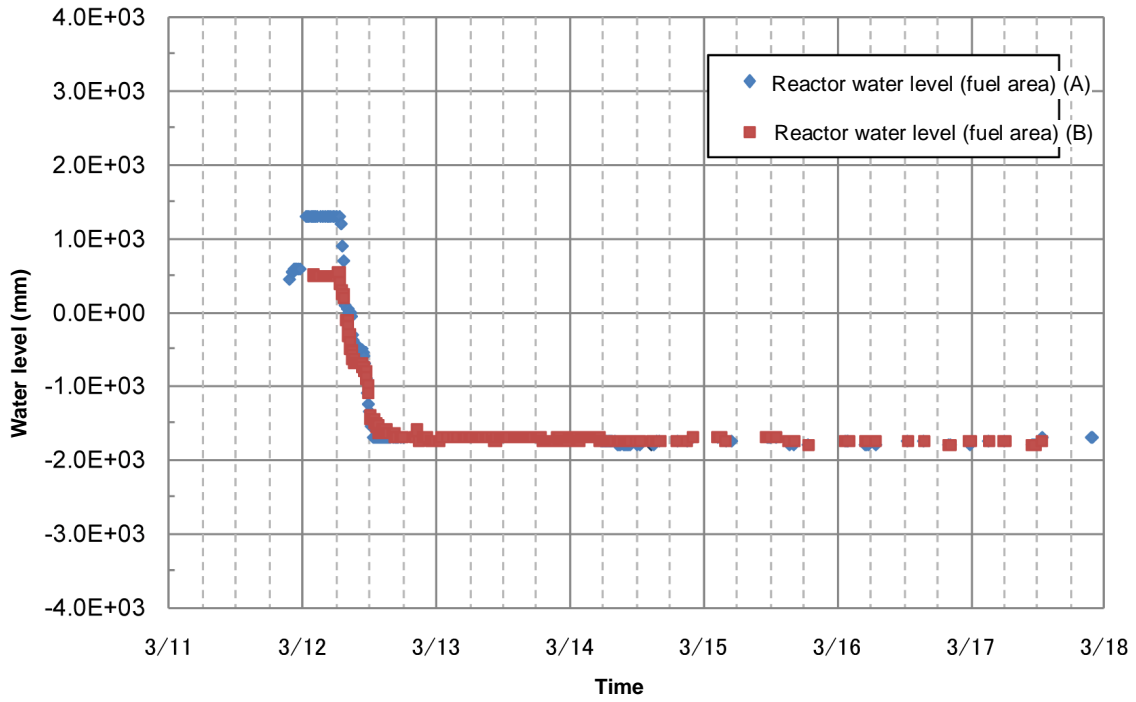

**Figure 2.2-2a Change in reactor water level (Unit 1)**

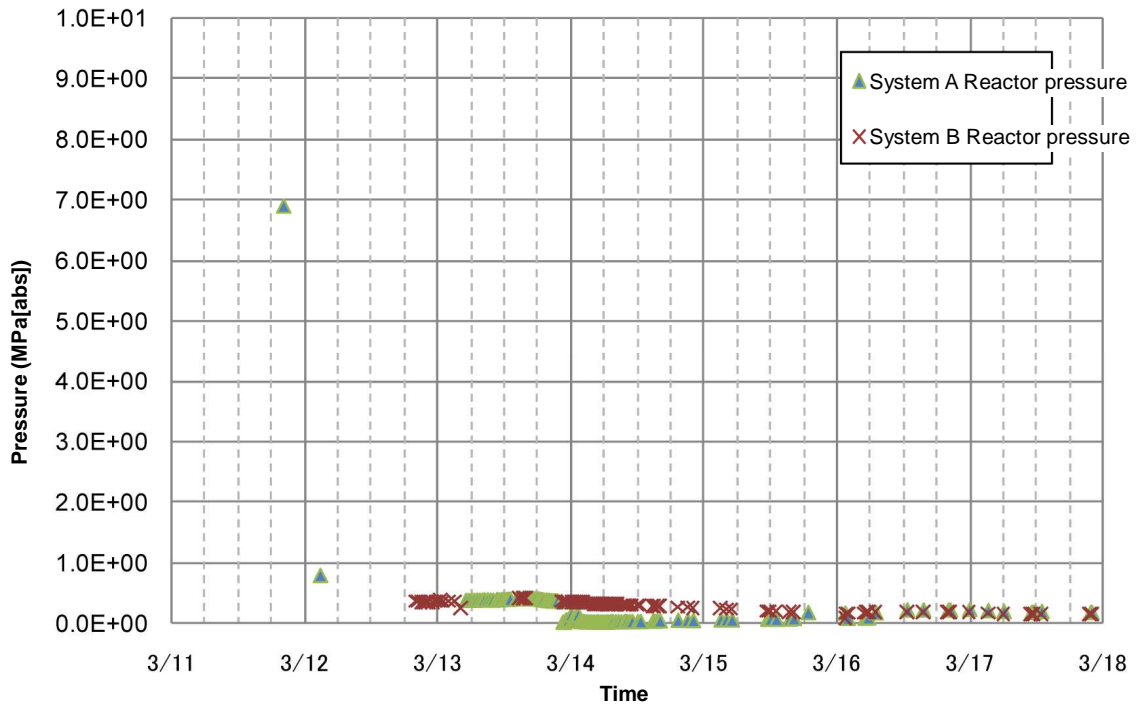

**Figure 2.2-2c Changes in reactor pressure (Unit 1)**

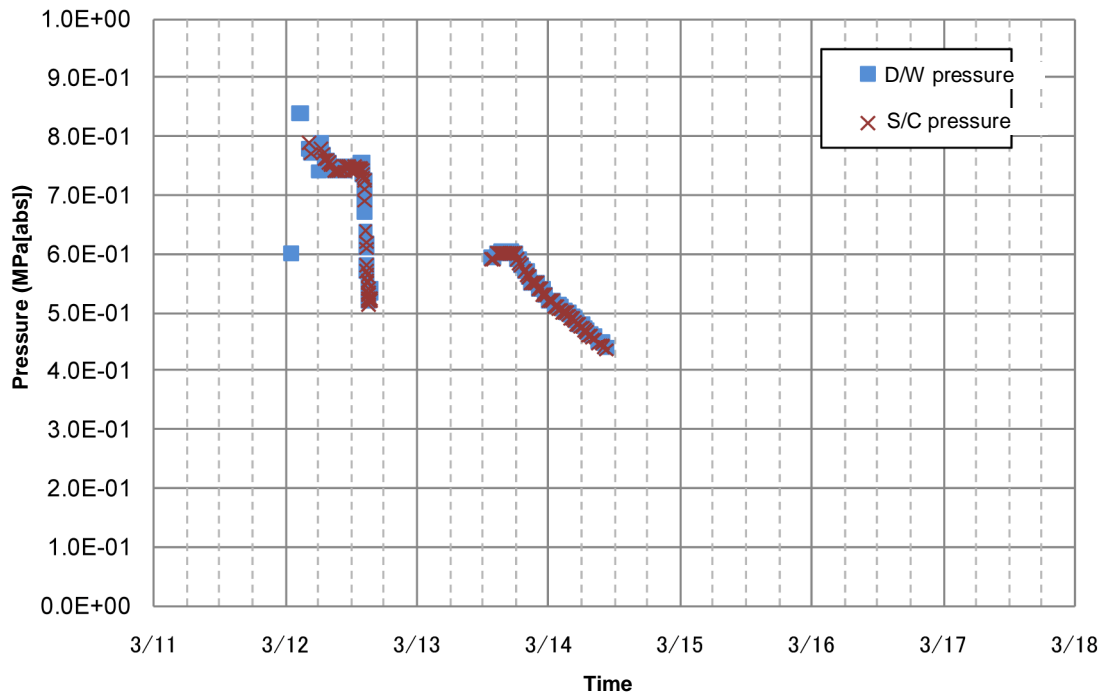

**Figure 2.2-2c Changes in containment vessel pressure (Unit 1)**

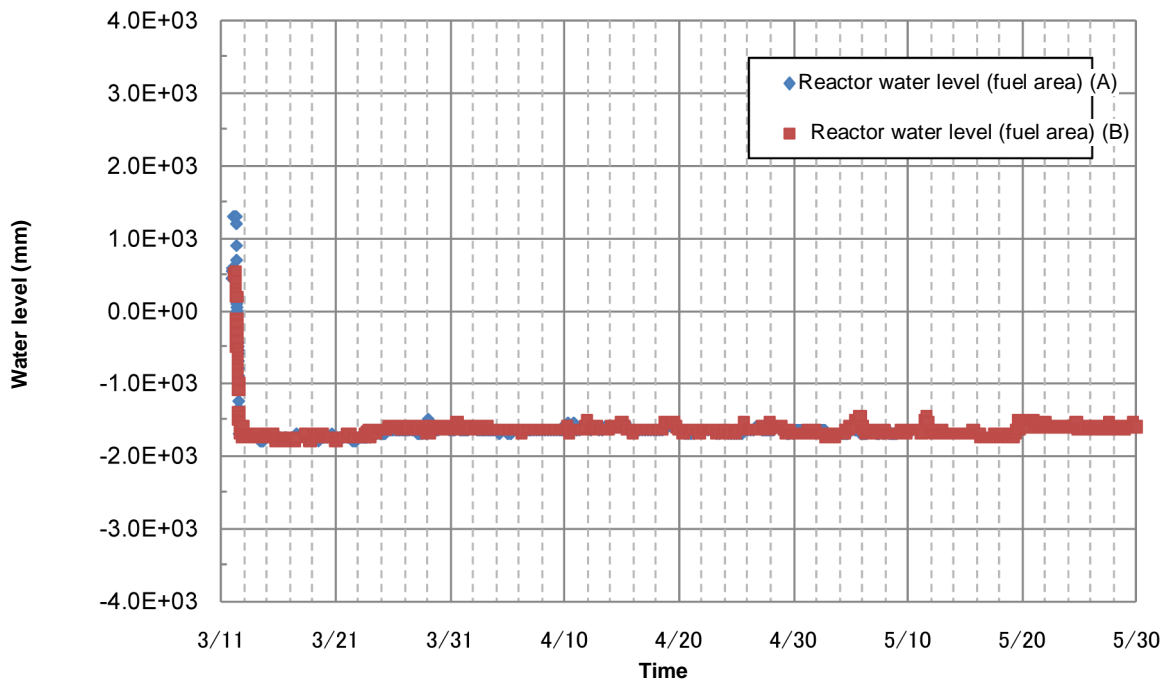

**Figure 2.2-3a Changes in reactor water level (Unit 1, long term)**

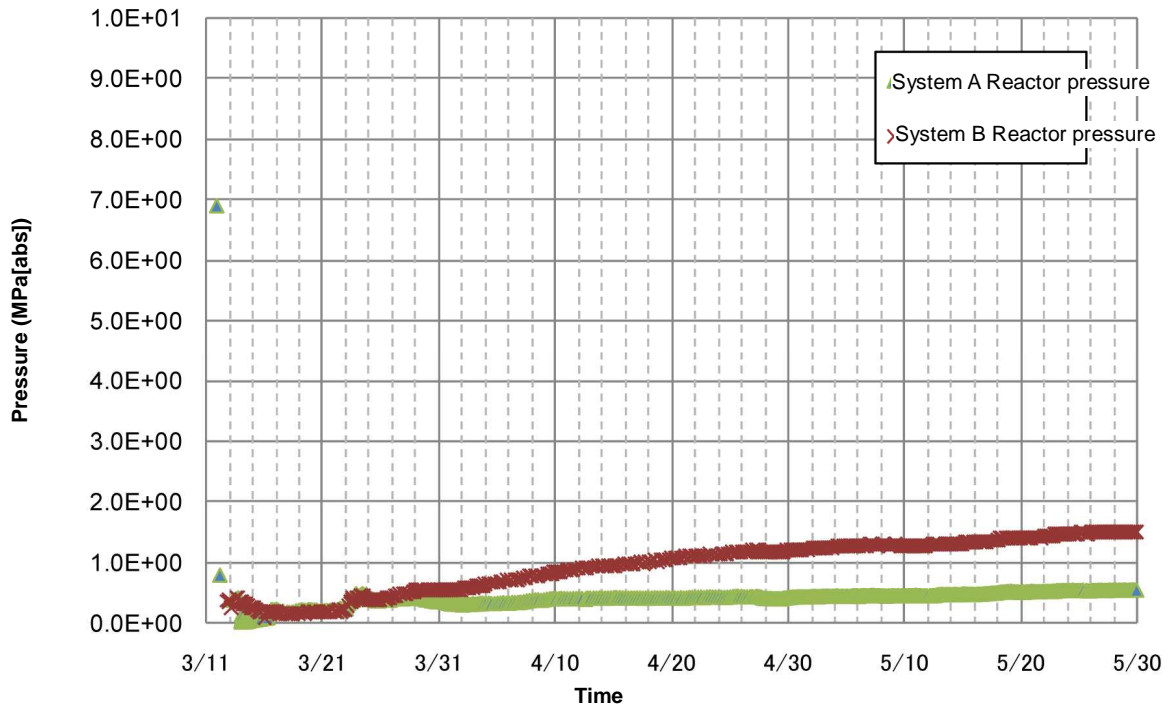

**Figure 2.2-3b Changes in reactor pressure (Unit 1, long term)**

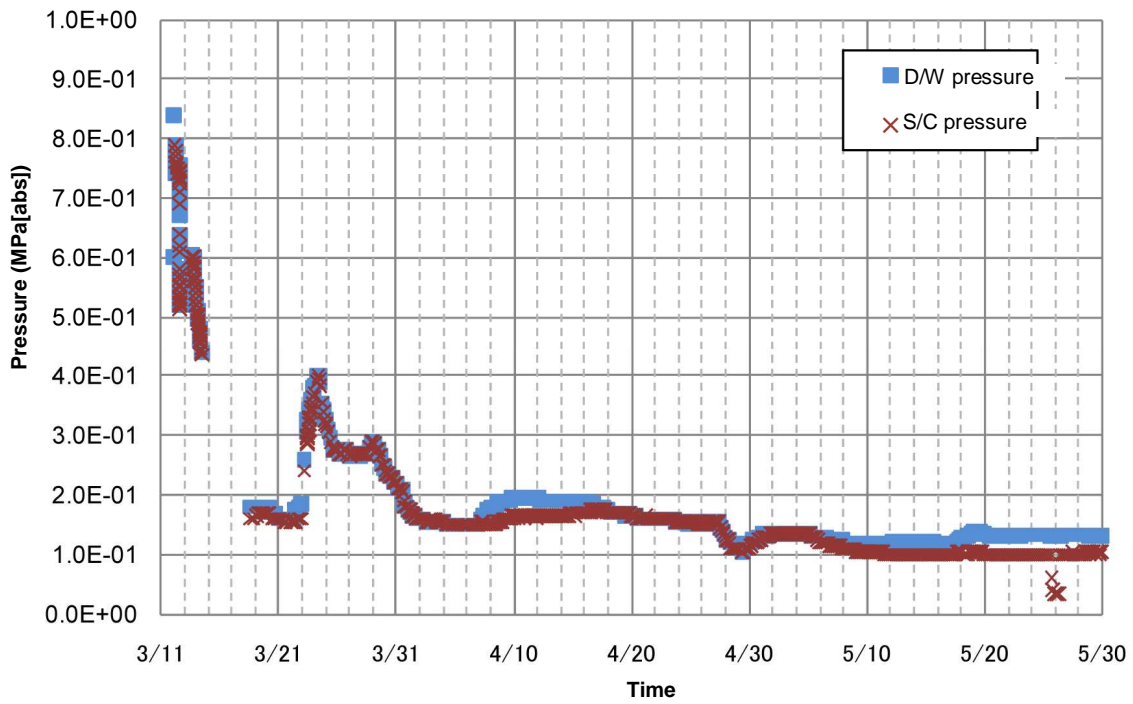

**Figure 2.2-3c Changes in containment vessel pressure (Unit 1, long term)**

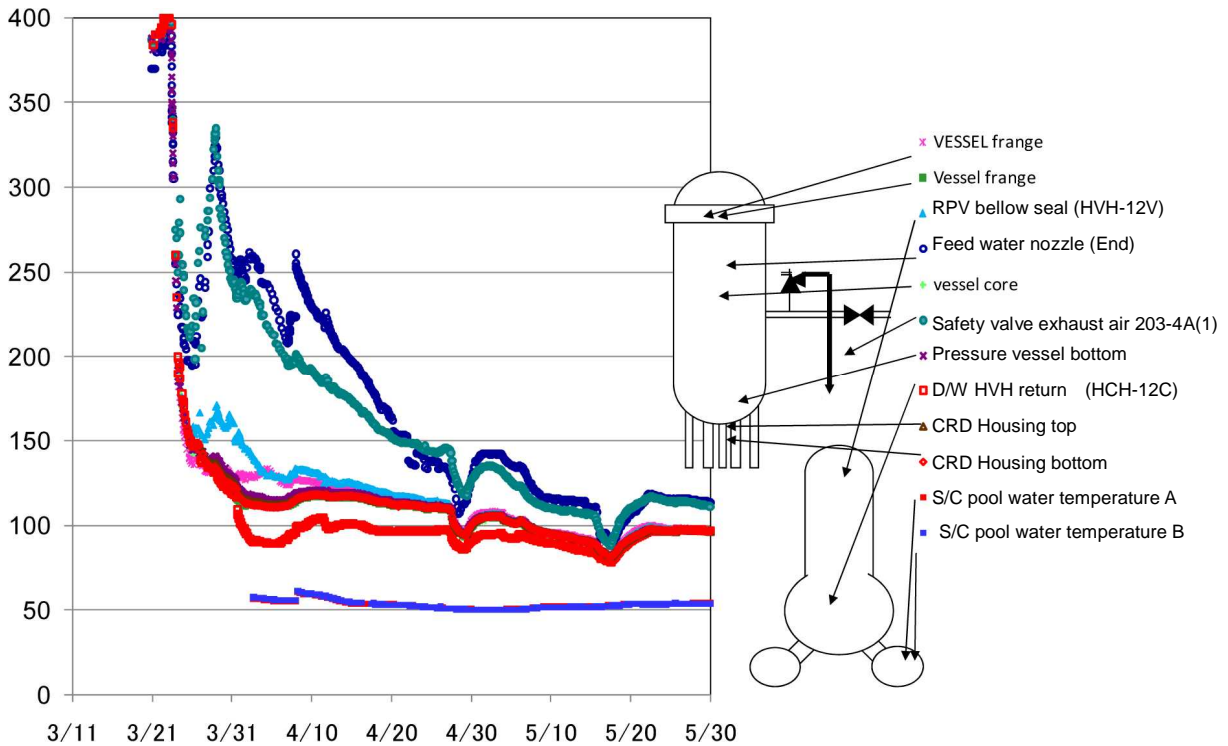

**Fig. 2.2-4c Changes in temperature (Unit 1, long term)**

## **2.3 Course of accident at Unit 2**

### **2.3.1 From occurrence of earthquake to arrival of tsunami**

Unit 2 was in constant thermal output operation at 2,381 WMt. Due to the earthquake, it automatically stalled at 14:47 on March 11 after receiving a 'large seismic acceleration' signal and all control rods were fully inserted into the reactor.

The earthquake damaged various units for the power plant, including power receiving circuit breakers for the Okuma No. 1 and 2 lines, causing a total loss of external power supply and loss of power supply for emergency bus conductors. Then, two DGs (2A and 2B) for emergency use started operating immediately and automatically to restore power supply to the emergency bus conductors.

Loss of power supply to the emergency bus conductors occurred at around 14:47 on March 11 and caused a loss of power supply for the nuclear reactor protection system, which resulted in an automatic closure of MSIV. This made the pressure in the nuclear reactor surge, but the main steam relief valve (hereafter called "SRV") controlled the pressure.

The water level in the nuclear reactor lowered immediately for a time after the nuclear reactor stopped automatically, due to a void collapse. However, after that, the level was successfully controlled by RCIC without reaching the level at which HPCI automatically starts (L-2: TAF+2,950 mm). For the RCIC, after the repetition of manual start by workers and then automatic start by receiving the 'nuclear reactor water level high' signal several times, it was manually started again at 15:39 on March 11, immediately before the massive tsunami hit the power plant.

Automatic opening and closing of the SRV and starting of the RCIC caused the temperature of the S/C pool water to rise. So, a residual heat removal system (hereafter called "RHR") was run from 15:00 to 15:07 on March 11 to cool down the S/C in the torus water cooling mode.

As mentioned above, from the time the earthquake occurred to the arrival of the tsunami, the measures taken were those normally done when external power supply is lost and there is a scram of a nuclear reactor.

### **2.3.2 From arrival of tsunami to malfunctioning of pressure suppression chamber**

The first tsunami arrived about 41 minutes after the earthquake hit the area, i.e., 15:27 on March 11, followed by the second tsunami at 15:35. The two tsunamis flooded and soaked seawater pumps for cooling and power panels. At 15:41 on the same day, both emergency DGs (2A and 2B) stopped and a Station Black Out occurred. D/C power supply was also lost. The management determined at 15:42 on March 11 that the situation corresponded to an event applicable to Article 10 of the Act on Special Law of Emergency Preparedness for Nuclear Disaster, i.e., a Station Black Out. Due to the station blackout, the RHR and the CS were unable to function.

Workers investigated the status of RCICs that could be run using D/C power source, but were unable to detect the status because the indicator lights in the central operating room and other lights had all gone out. Moreover, power supply to the measuring instruments was lost at 15:50 on the same day and the workers could not measure the water level in the nuclear reactors and D/W pressure. The

management thus determined at 16:36 on the same day that an event applicable to Article 15 of the Act on Special Law of Emergency Preparedness for Nuclear Disaster, i.e., cooling water unable to be supplied to emergency core cooling system, had occurred.

In order to secure a measure to supply cooling water to the nuclear reactor, the plant manager issued an instruction to examine the possibility of using an alternative way of supplying cooling water including FP, MUWC and RHR, which are installed as one of the measures against severe accidents and fire engines.

In conjunction with examining an alternative cooling water supply, the procedure for opening and closing the PCV valves without power supply for ventilation of PCVs was examined.

The following explain how an alternative cooling water supply was used and how PCV ventilation was made.

#### Alternative Cooling Water Supply

After examinations, the disaster countermeasures office in the Fukushima Daiichi Nuclear Power Station determined to construct an alternative cooling water supply line by way of RHR and construct a system so that cooling water could be supplied after reducing the pressure in the nuclear reactor (to 0.69 MPa [gauge]) via manually operating valves installed at such places as RHR system in R/B and T/B in the total darkness.

In order to restore the lights in the central operating room and monitoring instruments, the restoration team of the Station's disaster countermeasures office collected batteries and cables required for it, and at 20:49 on the same day, temporary lighting equipment was installed in the central operation room, using a portable power generator.

The Station still did not know the water level in the nuclear reactor or how cooling water was supplied to the reactor using RCIC. The management announced there was a possibility that the water level would reach the TAF level to all relevant people at 21:02 on the same day. At the same time, relevant organizations were notified that the estimated time of reaching TAF was 21:40.

After restoring power supply to instruments and other devices using the temporary power supply system, workers discovered that the level of water in the nuclear reactor was maintained at TAF+3,400 mm, at 21:50 on the same day.

Workers investigated how the RCIC was operated on site at around 2:00 on March 12. Though they were unable to obtain the data, they found that output pressure from the RCIC pump was higher than the pressure in the nuclear reactor. Thus, they determined that the RCIC was in operation, which was informed to the central operating room.

After the report was made, the Station's disaster countermeasures office determined that the RCIC was in operation and determined to continue monitoring parameters for Unit 2, at 2:55 on March 12.

Then, the water level in the condensate storage tank (hereafter called "CST") fell from 4:20 to 5:00 on the same day, so workers went on site to manually operate the valve to switch the water source to RCIC from the CST to the S/C.

The restoration team of the Station's disaster countermeasures office investigated how a power panel of Unit 2 was inundated and how its exterior was damaged, and measured its insulation resistance. It was revealed that part of the Power Center (P/C-2C and P/C-2D) was still usable. The control rod drive system (hereafter called "CRD") pumps that can inject high-pressure water to the reactor and SLC pumps may be used to supply water to the reactor by connecting a cable from a power supply vehicle to the power center. The method to carry it out was examined.

At around 15:30 on March 12, temporary cables were connected from a high tension power supply vehicle to the primary side of the power center for Unit 2 and power connection was completed.

Immediately after the connection, at 15:36 on the same day, an explosion occurred at the R/B of Unit 1, possibly a hydrogen gas explosion. This damaged the cables, which had just been laid, and the high tension power supply vehicle automatically stopped. Due to this explosion, the workers had to evacuate from the site temporarily and the restoration work was suspended till the safety of the site was confirmed.

On March 13, the high tension power supply vehicle that was connected to the Unit 2 power center was switched on again, but its protection system (overcurrent relay) stopped it from working.

The plant manager, in preparation for stoppage of RCIC, instructed the workers to get it ready for injecting seawater into the reactor, at 12:05 on March 13. In response to this instruction, fire engines were mobilized to lay down hoses to construct a seawater injection system, with a backwash valve pit of Unit 3 as the water source.

Another hydrogen gas explosion occurred at the R/B of Unit 3 at 11:01 on March 14. This damaged the fire engines and the hoses for seawater injection, which were ready to use, and made them unusable.

An on-site investigation started at 13:05 on the same day. After confirming how debris was scattered over the affected site, fire engines that were still usable were mobilized and hoses were laid again to start preparing for construction of a water injection system again; but this time, the seawater source was changed from the Unit 3 backwash valve pit to the cargo unloading station.

On the other hand, the RCIC were in operation, and the water level in the nuclear reactor was stably moved to over TAF+3,000 mm measured by an active fuel water level gauge from 22:00 on March 11 to around 12:00 on March 14. The water level, however, showed a downing trend at around 13:18 on March 14, which continued thereafter. The management determined at 13:25 on March 14 that the situation corresponded to an event applicable to Article 15 of the Act on Special Law of Emergency Preparedness for Nuclear Disaster, i.e., loss of capacity to cool down a nuclear reactor, after RCIC lost its function.

Work to connect seawater injection lines to inject seawater to the reactor from fire engines using FP lines was completed at 14:43 on March 14.

In order to inject seawater to the reactor from the fire engines, it was necessary to reduce pressure in the reactor by manually opening the SRVs. However, the temperature and pressure of the S/C remained high (the temperature and

pressure in the S/C were 149.3 °C and 486 kPa [abs] respectively at 12:30 on March 14). The condition was such that even if the SRVs were opened manually, it was not likely that steam in the S/C would condensate and the pressure would be reduced.

So, the Station's disaster countermeasures office decided to inject seawater after ventilating the PCV to reduce the S/C pressure then to reduce the pressure inside the reactor using the SRVs.

However, thereafter, it was likely that it would take time till the PCV valve was manually opened. The plant manager, at around 16:00 on March 14, decided to reduce the pressure using the SRVs first and instructed the workers to ventilate the PCV at the same time. Preparations were made around 16:30 on the same day so that seawater injection could be started as soon as the fire engine pump was run and the pressure in the reactor was reduced to an acceptable level.

As the DC power supply to open the SRVs was lost, batteries in the vehicles that had been parked on high ground and were unaffected by the tsunami were collected to the central operating room and they were prepared to be used as a power source for operating the SRVs by connecting the batteries to the power cable. The pressure in the reactor was reduced and opening of the SRVs started at 16:34 on March 14. The voltage of the battery was not sufficient. So batteries were added and the opening operation of more than one SRV continued.

Meanwhile, the water level of the reactor reached TAF at 17:17 on March 14.

Pressure reduction by opening SRVs started at around 18:00 on March 14. However, the high temperature and pressure in the S/C prevented steam from condensing and it took time till the pressure was reduced. (The pressure in the reactor was 6.998 MPa [gage] at 16:43, 6.075 MPa [gage] at 18:03, and 0.63 MPa [gage] at 19:03 on March 14.)

During this period, at 18:22 on March 14, the water level in the reactor fell to TAF-3,700 mm and the entire fuel rods were exposed.

The radiation dose at the site was too high to have the operation condition of the fire engines monitored for a long time by the same person, so the workers took turns in monitoring. At 19:20 on the same day, fire engines waiting to inject seawater into the reactor were found to have stopped at the site due to a fuel shortage.

The fire engines were refueled and seawater injection by them using the FP line was started at 19:54 on the same day. (One each of the fire engines was operated at 19:54 and 19:57 on March 14.)

When the SRV2 valve was manually opened at 21:20 on the same day, the water level in the reactor showed a slight recovery. (The water level in the reactor was TAF-3,000 mm at 21:30 on March 14.)

### PCV Ventilation

Starting from the evening of March 11, the workers examined how to open the PCV ventilation valves without any power supply, in conjunction with an examination on alternative methods for water injection.

The power supply to measuring instruments was lost due to the tsunami and the D/W pressure was unknown. However, the measuring instruments were restored

at around 23:25 on March 11 and it was found that the D/W pressure was 0.141 MPa [abs].

As it was found that RCIC for Unit 2 was in operation at 2:55 on March 12, the Station decided to ventilate the PCV of Unit 1 first and to continue monitoring the parameters for Unit 2.

Meanwhile, water injection to the reactor using RCIC was continued and the D/W pressure shifted stably around 200 to 300 kPa [abs]. However, the Station reasonably assumed that ventilation of the PCV was going to be necessary. The plant manager issued an instruction at 17:30 on March 12 to start preparing for PCV ventilation for Unit 2.

In line with the operating manual, at 8:10 on March 13, the workers manually opened the MO valve at 25%. This is one of the two valves (MO valve and AO valve) that are serially installed in the PCV ventilation line.

At 10:15 on March 13, the plant manager instructed the workers to open the remaining AO valve. Following this order, at 11:00 on the same day, the workers opened the AO valve (large valve) by forcibly energizing a solenoid valve using the power source supplied by a small-sized power generator for temporary lighting in the central operating room. This completed forming the PCV ventilation line system excluding a rupture disc. The D/W pressure at this time was still lower than the working pressure for the rupture disc (i.e., 427 kPa [gage]) and under such a low pressure, ventilation of the PCV could not be done. So the valves in the ventilation line were left open and the D/W pressure was continually monitored.

The Station informed the result of evaluating the dose of radiation exposed to the areas neighboring the plant when the PCV ventilation was done to the relevant organizations at 15:18 on March 13.

An explosion, possibly of hydrogen gas, occurred at the R/B of Unit 3 at 11:01 on March 14. All workers excluding workers at the central operating room stopped the entire work and evacuated to the antiseismic building.

The D/W pressure was shifting at around 450 kPa [abs] in a stable manner, which was lower than the working pressure for the rupture disc.

Due to the explosion in Unit 3, the circuit for energizing a solenoid valve for the AO valve (large valve), which was on the ventilation line from S/C, which was being constructed, was disconnected and closed. After the evacuation order was lifted, at around 16:00 on March 14, the workers performed an operation to open the valve again but in vain, due to an insufficient air supply from the air compressor temporarily installed, or other reasons. (Thereafter, the reason was assumed to be a malfunctioned solenoid valve.) Due to this, the workers began building a ventilation line using the AO valve (small valve) installed on the ventilation line connecting from the S/C, at around 18:35 on March 14. At around 21:00 on the same day, the AO valve (small valve) was opened and the PCV ventilation line system was recreated, excluding the rupture disc.

As the D/W pressure exceeded 427 kPa [gage], or the maximum working pressure, at 22:50 on March 14, the Station determined the situation corresponded to an event applicable to Article 15 of the Act on Special Law of Emergency Preparedness for Nuclear Disaster, i.e., abnormal pressure surge in a primary containment vessel (PCV).

The D/W pressure tended to go up but the S/C pressure was shifting around 300 to 400 kPa [abs] in a stable manner. This caused an irregular distribution of pressure in the PCVs.

As the pressure on the S/C side was lower than the working pressure of the rupture disc, and as the pressure on the D/W side surged, the Station decided at around 23:35 on March 14 to carry out a measure to initiate PCV ventilation by opening the AO valve (small valve) on the ventilation line connected from D/W.

At around 0:02 on March 15, the AO valve (small valve) on the ventilation line from the D/W was opened, but several minutes later, it closed again. The D/W pressure shifted at a high level.

At 3:00 on the same day, the workers tried to reduce the D/W pressure and inject water into the nuclear reactor but the reactor's pressure could not be reduced to a sufficiently low level.

At around 6:00 or 6:10 on March 15, a big boom was heard and around the same time, the pressure of the S/C became 0 MPa [abs].

At 6:50 on the same day, the radiation dose around the main gate showed 583.7  $\mu\text{Sv/h}$ , which is higher than 500  $\mu\text{Sv/h}$  — the threshold level determined as an abnormal level of radiation. So the Station determined the situation corresponded to an event applicable to Article 15 of the Act on Special Law of Emergency Preparedness for Nuclear Disaster, i.e., abnormal surge of radiation dose at the boundary of the premises.

At around 7:00 on March 15, the workers in the antiseismic building, except for those required for emergency restoration work and monitoring, left the plant to go to Fukushima Daini Nuclear Power Station, hereafter called "Fukushima Daini" temporarily.

Thereafter, parameters such as D/W pressure were taken by the workers every few hours at the central operating room. At around 11:25 on March 15, the D/W pressure showed a decrease (730 kPa [abs] at 7:20 and 155 kPa [abs] at 11:25 on March 15).

### **2.3.3 Major events thereafter**

Inspection and trial recharging of the Station's access to electricity from TEPCO's Nuclear Power Grid owned by Tohoku Electric Co., Ltd. were completed on March 15, and then electricity was received by the Power Center on March 20. Now an external power source had been secured. Then on March 26, the lighting of the MCR was restored.

As an alternative way to inject water into the nuclear reactor, seawater had been used up to March 26. But on the same day, fresh water supplied from temporary tanks was used. On the following day, March 27, the pumps used were changed from fire pumps to temporary electric pumps. From April 3 onward, power supply to the plant was restored from a temporary power supply system.

#### **2.3.4 Condition of spent fuel pool**

As of March 11, a total of 587 spent fuel rods and 28 new fuel rods were stored in the spent fuel pool (SFP) of Unit 2. The Station estimated that the decay heat generated by these fuels in the SFP was approximately 0.62 MWt (as of March 11).

The earthquake that occurred at 14:46 on March 11 caused a total loss of external power supply to the plant, and the FPC came to a halt. The massive tsunami that hit the plant after the earthquake caused a station blackout and the functions of cooling and supplying water to the SFP were lost.

The explosion of the R/B of Unit 1 that occurred at 15:36 on March 12 blew away the blow out panel of R/B in Unit 2 and white smoke was observed coming out of the blow out panel.

On March 20, seawater was injected to the SFP using FRC pipes already laid. When injection of seawater to the SFP was done again on March 22, the water level surged in the skimmer surge tank, meaning the SFP was totally filled with water.

From March 29 onward, the type of water was switched from seawater to fresh water.

It is considered that these water injections were successful in keeping the water level in the SFP sufficiently high to prevent the fuel rods being exposed to the air.

**Table 2.3-1 Time-Course Progress (Unit 2)**

March 11, 2011 (Fri.)

14:46	Great East Japan Earthquake occurs. Alert Level 3 automatically issued.
14:47	Scram of nuclear reactors automatically occurs and main turbine automatically stops. Emergency DG automatically activated.
14:50	RCIC manually started.
14:51	RCIC stops (due to high water level in the reactor).
15:01	Subcriticality of the nuclear reactor confirmed.
15:02	RCIC manually started.
15:06	A disaster countermeasures office established in the TEPCO head office (to understand the damage conditions due to the earthquake and restoration from blackout).
15:27	First tsunami arrives.
15:28	RCIC stops (due to high water level in the nuclear reactor).
15:35	Second tsunami arrives.
15:39	RCIC manually started.
15:41	Station Black Out occurs.
15:42	Determined the occurrence of a special event applicable to Paragraph 1, Article 10 of the Act on Special Law of Emergency Preparedness for Nuclear Disaster (Station Black Out). Notified the same to governmental agencies and other relevant organizations.
15:42	Alert Level 1 issued. An emergency task force established (as a joint headquarters with disaster countermeasures office).
16:36	Water level in the reactors is unable to be confirmed and how water is injected is known. So the Station determines that a special event applicable to Paragraph 1, Article 15 of the Act on Special Law of Emergency Preparedness for Nuclear Disaster has occurred (cooling water unable to be supplied to emergency core cooling system), and at 16:45 the same is notified to the governmental agencies and other relevant organizations.
16:36	Alert Level 2 issued.
17:12	The plant manager instructs workers to start an examination to find a way to inject water into the nuclear reactors using the FP lines installed in preparation for severe accidents and fire engines.
20:49	Temporary lighting installed and used within the MCR.
20:50	Fukushima Prefecture directs local residents living within a 2 km radius from the Fukushima Daiichi Nuclear Power Station to evacuate.
21:02	As the water level in the nuclear reactors is unidentified and how water is injected to them by RCIC cannot be confirmed, the Station sends a notice to governmental agencies and other relevant organizations saying that the water level could reach TAF.
21:13	The time for reaching TAF is estimated as 21:40, which is conveyed to governmental agencies and other relevant organizations.
21:23	The Prime Minister directs local residents living within a 3 km radius from the power plant to evacuate and those living within a 3 km to 10 km radius to stay indoors.
22:00	Water level in the reactors is identified as TAF+3,400 mm. So the Station assesses that it will take more time before reaching the level of TAF. The Station notifies governmental agencies and other relevant organizations of this at 22:10 and 22:20.

March 12, 2011 (Sat.)

0:30	Completion of evacuation of the local residents confirmed by the Government of Japan (confirmed evacuation of people living within 3 km from the plant in Futaba City and Okuma City, and reconfirmed it at 1:45).
------	--

Around 1:30 Ventilation of Unit 1 and Unit 2 requested to the Prime Minister, the Minister of METI and Nuclear and Industrial Safety Agency, to which an approval is granted.

2:55 Confirmed RCIC is in operation.

3:06 Held a press meeting on initiation of the ventilation.

3:33 Notified to the governmental agency of the results of radiation exposure evaluation to be released when the ventilation is done.

4:55 Confirmed surge of radiation dose within the plant premises surges (around the main gate: goes from 0.069  $\mu\text{Sv/h}$  (at 4:00) to 0.059  $\mu\text{Sv/h}$  (at 4:23). The same is notified to governmental agencies and other relevant organizations.

5:44 The Prime Minister directs local residents living within a 10 km radius from Fukushima Daiichi Nuclear Power Station to evacuate.

6:50 The Minister of METI issues an order to initiate ventilation (manual ventilation) pursuant to the relevant laws.

7:11 The Prime Minister arrives at the Fukushima Daiichi Nuclear Power Station.

8:04 The Prime Minister leaves the Fukushima Daiichi Nuclear Power Station.

16:27 A radiation dose of over 500  $\mu\text{Sv/h}$  at the MP i.e., 1,015  $\mu\text{Sv/h}$  observed and the Station determines that a special event applicable to Paragraph 1, Article 15 of the Act on Special Law of Emergency Preparedness for Nuclear Disaster has occurred (abnormal surge of radiation dose at the boundary of the premises). The same is notified to governmental agencies and other relevant organizations.

17:30 The plant manager issues an instruction to start preparation for PCV ventilation.

18:25 The Prime Minister directs local residents living within a 20 km radius from the Fukushima Daiichi Nuclear Power Station to evacuate.

#### March 13, 2011 (Sun.)

8:10 A ventilation valve (MO valve) of primary containment vessels (hereafter called "PCVs") is opened.

8:56 A radiation dose of over 500  $\mu\text{Sv/h}$  at the MP i.e., 882  $\mu\text{Sv/h}$  observed and the Station determines that a special event applicable to Paragraph 1, Article 15 of the Act on Special Law of Emergency Preparedness for Nuclear Disaster has occurred (abnormal surge of radiation dose at the boundary of the premises). The same is notified to governmental agencies and other relevant organizations at 9:01.

10:15 The plant manager instructs the workers to start the ventilation.

11:00 A ventilation line is established, excluding rupture discs.

11:00 The Prime Minister directs local residents living within a 20 km to 30 km radius from the Fukushima Daiichi Nuclear Power Station to stay indoors.

11:20 Held a press meeting on initiation of PCV ventilation.

12:05 The plant manager instructs workers to prepare for using seawater.

14:15 A radiation dose of over 500  $\mu\text{Sv/h}$  at the MP i.e., 905  $\mu\text{Sv/h}$  observed and the Station determines that a special event applicable to Paragraph 1, Article 15 of the Act on Special Law of Emergency Preparedness for Nuclear Disaster has occurred (abnormal surge of radiation dose at the boundary of the premises). The same is notified to governmental agencies and other relevant organizations at 14:23.

15:18 Notified governmental agencies and other relevant organizations of the result of radiation exposure evaluation to be released when PCV ventilation is done.

#### March 14, 2011 (Mon.)

2:20 A radiation dose of over 500  $\mu\text{Sv/h}$  at around the main gate i.e., 751  $\mu\text{Sv/h}$  observed and the Station determines that a special event applicable to Paragraph 1, Article 15 of the Act on Special Law of Emergency Preparedness

for Nuclear Disaster has occurred (abnormal surge of radiation dose at the boundary of the premises). The same is notified to governmental agencies and other relevant organizations at 4:24.

2:40 A radiation dose of over 500  $\mu\text{Sv/h}$  at the MP i.e., 650  $\mu\text{Sv/h}$  observed and the Station determines that a special event applicable to Paragraph 1, Article 15 of the Act on Special Law of Emergency Preparedness for Nuclear Disaster has occurred (abnormal surge of radiation dose at the boundary of the premises). The same is notified to governmental agencies and other relevant organizations at 5:37.

4:00 A radiation dose of over 500  $\mu\text{Sv/h}$  at the MP i.e., 820  $\mu\text{Sv/h}$  observed and the Station determines that a special event applicable to Paragraph 1, Article 15 of the Act on Special Law of Emergency Preparedness for Nuclear Disaster has occurred (abnormal surge of radiation dose at the boundary of the premises). The same is notified to governmental agencies and other relevant organizations at 8:00.

9:12 A radiation dose of over 500  $\mu\text{Sv/h}$  at the MP i.e., 518.7  $\mu\text{Sv/h}$  observed and the Station determines that a special event applicable to Paragraph 1, Article 15 of the Act on Special Law of Emergency Preparedness for Nuclear Disaster has occurred (abnormal surge of radiation dose at the boundary of the premises). The same is notified to governmental agencies and other relevant organizations at 9:34.

11:01 Explosion of R/B of Unit 3 caused the large valve of the S/C ventilation valve (AO valve) closed. Confirmed it is unable to be opened. The completed water injection line is found unable to be used due to damages to the fire engines and hoses.

13:05 Establishment of a seawater injection line restarted, including fire engines.

13:18 As the water level in the reactor tends to be lowering, the Station notifies the governmental agencies and other relevant organizations that it will immediately start preparing to inject seawater into the reactor.

13:25 The water level in the reactor keeps decreasing and there is a possibility that the RCIC is not functioning. The Station determines that a special event applicable to Paragraph 1, Article 15 of the Act on Special Law of Emergency Preparedness for Nuclear Disaster has occurred (loss of capacity to cool down a nuclear reactor). The same is notified to governmental agencies and other relevant organizations at 13:38.

15:28 Time to reach the TAF estimated as 16:30. The same is notified to governmental agencies and other relevant organizations.

16:30 Fire engines start injecting seawater into the reactor.

16:34 The Station notifies governmental agencies and other relevant organizations that it will start reducing the pressure in the nuclear reactor and injecting seawater from the FP lines.

17:17 The water level in the nuclear reactor reached TAF. The same is notified to governmental agencies and other relevant organizations at 17:25.

Around 18:00 The Station starts reducing the pressure in the nuclear reactor (from 5.4 MPa to 0.63 MPa at 19:03).

18:22 The water level in the nuclear reactor reached TAF-3,700 mm. The Station determined that the whole of the fuel rods have been exposed to the air. The same is notified to governmental agencies and other relevant organizations at 19:32.

19:20 Confirmed that fire engines that are injecting seawater into the nuclear reactor have stopped because they have run out of fuel.

19:54 Started using fire engines to inject seawater into the nuclear reactor from the FP line (one each operated at 19:54 and 19:57).

Around 21:00 A small valve of the S/C ventilation valve (AO valve) opened. A ventilation line excluding rupture discs completed.

21:20 Two valves of SRVs opened. Confirmed that the water level in the nuclear

- reactor has improved. The same is notified to governmental agencies and other relevant organizations at 21:34. (As of 21:30, the water level of the nuclear reactor is TAF-3,000 mm.)
- 21:35 A monitoring car recorded a radiation dose of over 500  $\mu\text{Sv/h}$  at the MP i.e., 760  $\mu\text{Sv/h}$  and the Station determines that a special event applicable to Paragraph 1, Article 15 of the Act on Special Law of Emergency Preparedness for Nuclear Disaster has occurred (abnormal surge of radiation dose at the boundary of the premises). The same is notified to governmental agencies and other relevant organizations at 22:35.
- 22:50 The D/W pressure exceeds its maximum working pressure, i.e., 427 kPa [gage] and the Station determines that a special event applicable to Paragraph 1, Article 15 of the Act on Special Law of Emergency Preparedness for Nuclear Disaster has occurred (abnormal pressure surge in a primary containment vessel (PCV)). The same is notified to governmental agencies and other relevant organizations at 23:39.
- Around 23:35 The pressure on the S/C side is lower than the pressure required to operate a rupture disc, and as the pressure on the D/W side is surging, the plant determined to initiate ventilation by opening a small valve of the D/W ventilation valve.
- March 15, 2011 (Tue.)
- 0:02 A small valve of the D/W ventilation valve (AO valve) opened. A ventilation line excluding rupture discs completed. (Confirmed that the valve is in closed position a few seconds later.)
- 3:00 The D/W pressure exceeds its design maximum working pressure. The Station notifies governmental agencies and other relevant organizations at 4:17 that it is working to reduce the pressure and inject water into the nuclear reactor, but the pressure still remains high.
- Around 6:00 to 6:10 The S/C pressure indicates 0 MPa (abs). (Around the same time, a big boom is heard on the premises.)
- 6:50 A radiation dose of over 500  $\mu\text{Sv/h}$  around the main gate i.e., 583.7  $\mu\text{Sv/h}$  observed and the Station determines that a special event applicable to Paragraph 1, Article 15 of the Act on Special Law of Emergency Preparedness for Nuclear Disaster has occurred (abnormal surge of radiation dose at the boundary of the premises). The same is notified to governmental agencies and other relevant organizations at 7:00.
- 7:00 Notified governmental agencies and other relevant organizations that all workers, excluding those required to remain in the plant, will evacuate to Fukushima Daini Nuclear Power Station temporarily.
- 8:11 A radiation dose of over 500  $\mu\text{Sv/h}$  around the main gate i.e., 807  $\mu\text{Sv/h}$  observed and the Station determines that a special event applicable to Paragraph 1, Article 15 of the Act on Special Law of Emergency Preparedness for Nuclear Disaster has occurred (abnormal release of radioactive substances due to a fire and an explosion). The same is notified to governmental agencies and other relevant organizations at 8:36. Confirmed white smoke (steam or the like) is generated at the 5F of the R/B at 8:25. The same is notified to governmental agencies and other relevant organizations at 9:18.
- 16:00 A radiation dose of over 500  $\mu\text{Sv/h}$  at the main gate i.e., 531.6  $\mu\text{Sv/h}$  observed and the Station determines that a special event applicable to Paragraph 1, Article 15 of the Act on Special Law of Emergency Preparedness for Nuclear Disaster has occurred (abnormal surge of radiation dose at the boundary of the premises). The same is notified to governmental agencies and other relevant organizations at 16:22.
- 23:05 A radiation dose of over 500  $\mu\text{Sv/h}$  around the main gate i.e., 4,548  $\mu\text{Sv/h}$

observed and the Station determines that a special event applicable to Paragraph 1, Article 15 of the Act on Special Law of Emergency Preparedness for Nuclear Disaster has occurred (abnormal surge of radiation dose at the boundary of the premises). The same is notified to governmental agencies and other relevant organizations at 23:20.

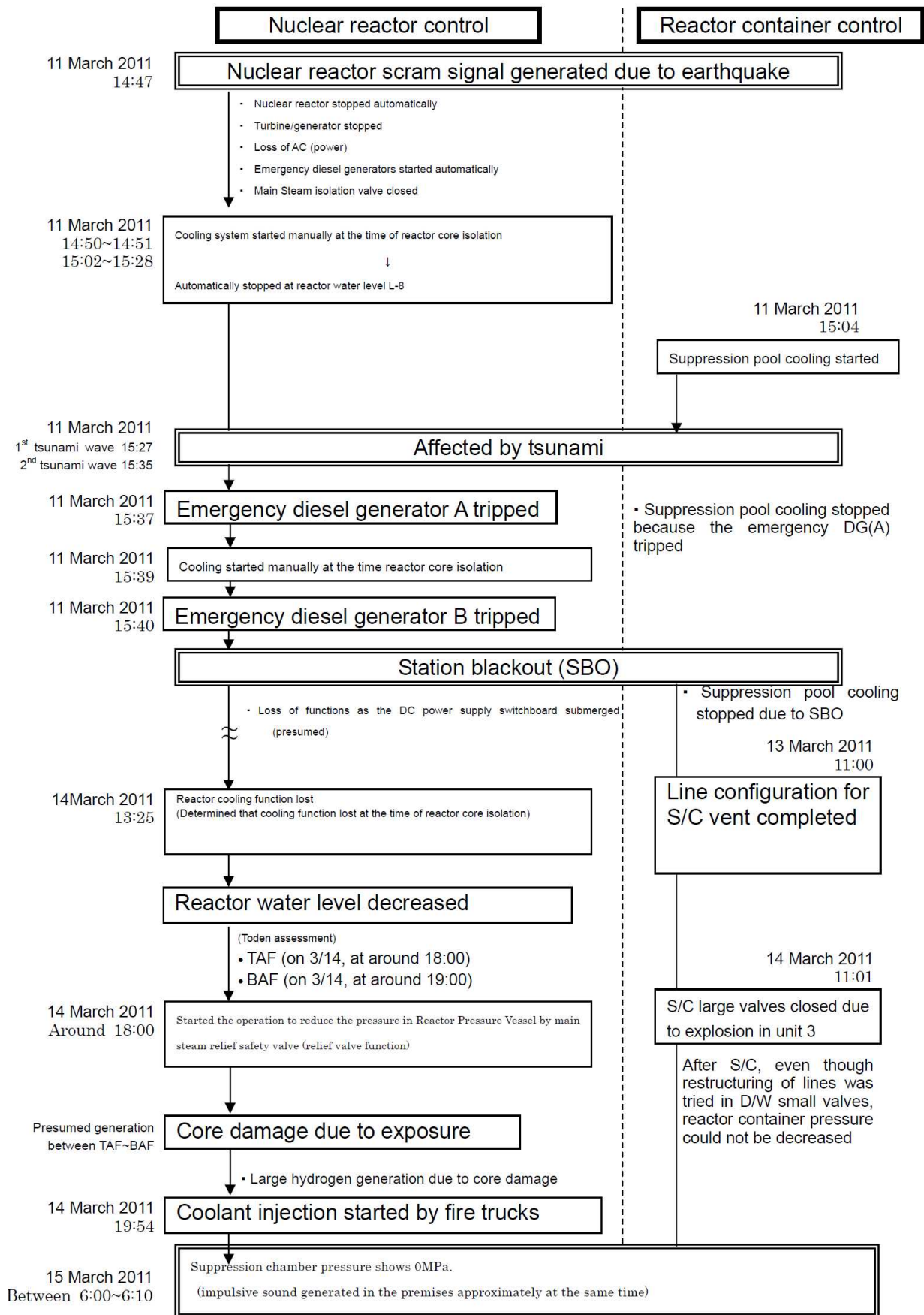

**Fig. 2.3-1: Flows of the Accident at Unit 2 of the Fukushima Daiichi Nuclear Power Station after the Earthquake**

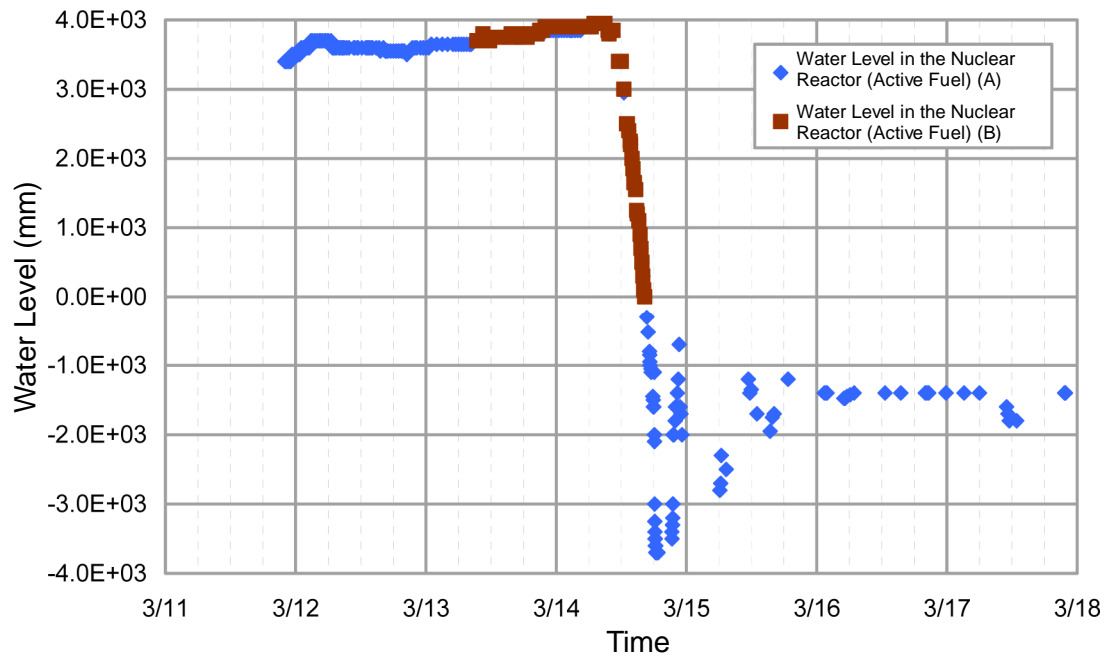

**Fig. 2.3-2a: Shift of the Water Level in the Nuclear Reactor (Unit 2)**

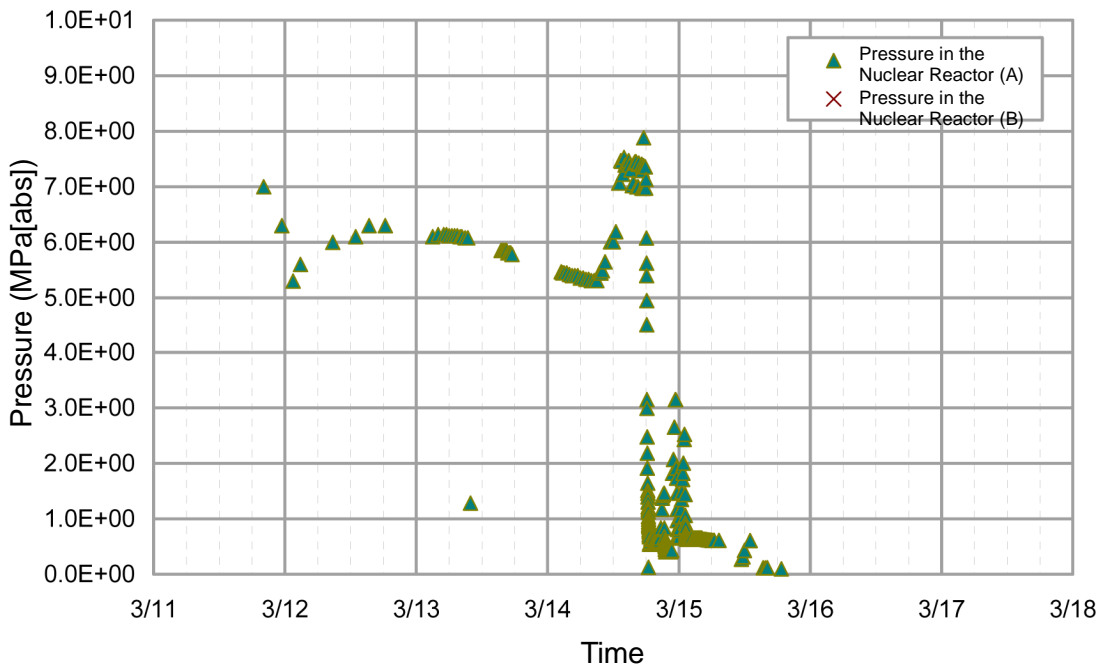

**Fig. 2.3-2b: Shift of Pressure in the Nuclear Reactor (Unit 2)**

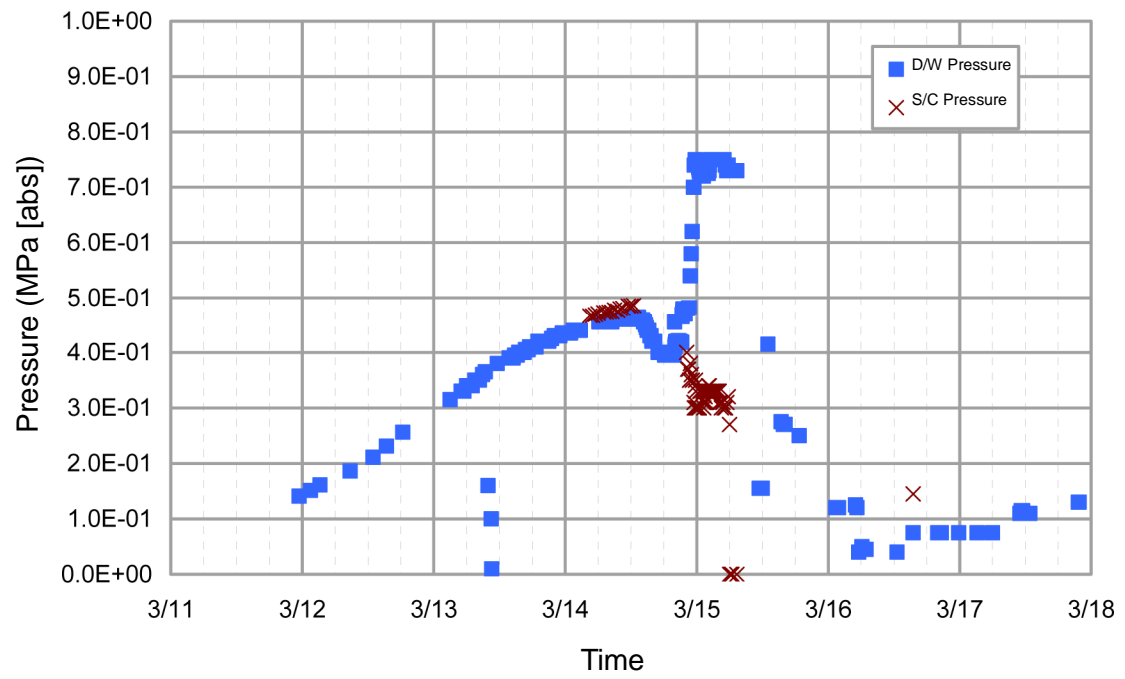

**Fig. 2.3-2c: Shift of the Pressure in the Primary Containment Vessel (Unit 2)**

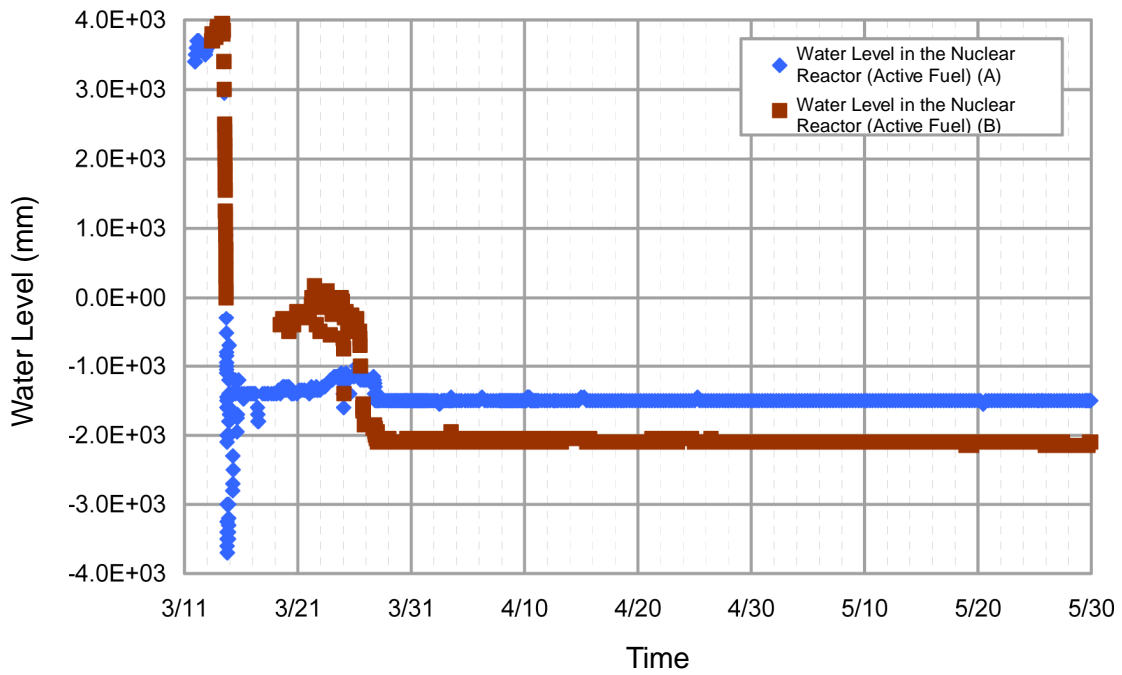

**Fig. 2.3-3a: Shift of the Water Level in the Nuclear Reactor (Unit 2: Long Term)**

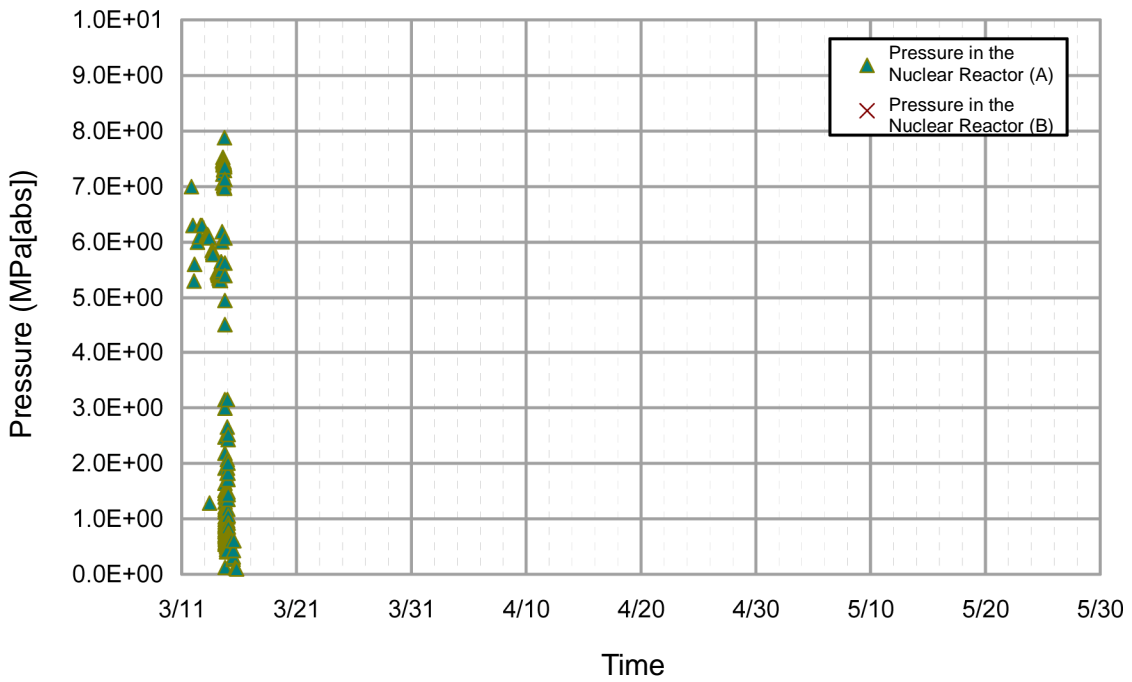

**Fig. 2.3-3b: Shift of Pressure in the Nuclear Reactor (Unit 2: Long Term)**

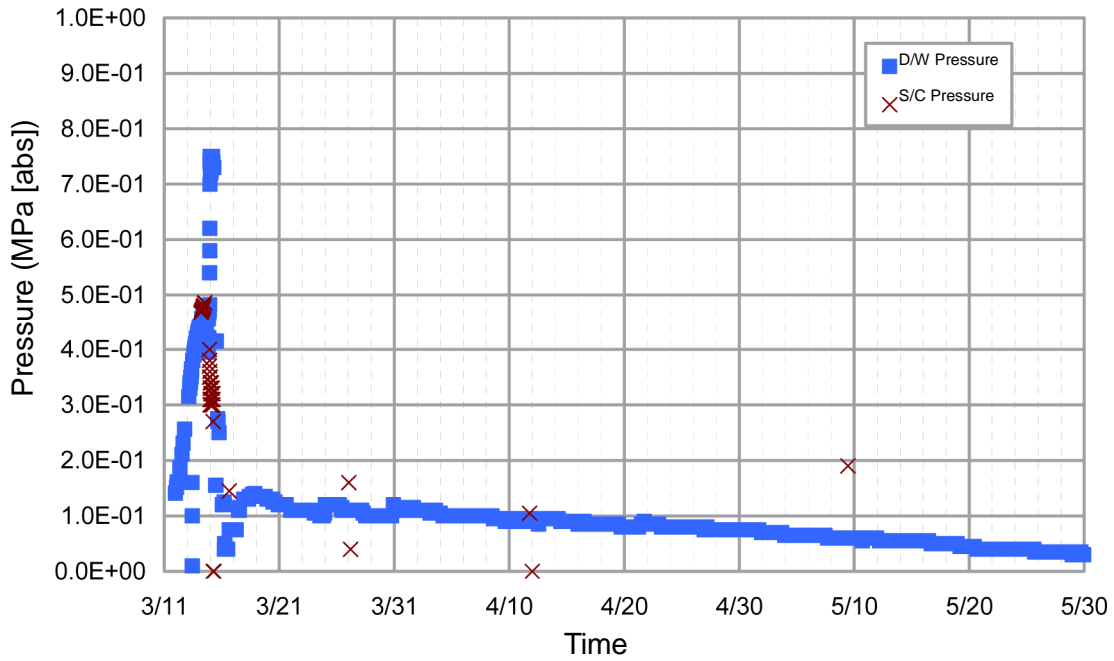

**Fig. 2.3-3c: Shift of the Pressure in the Primary Containment Vessel (Unit 2: Long Term)**

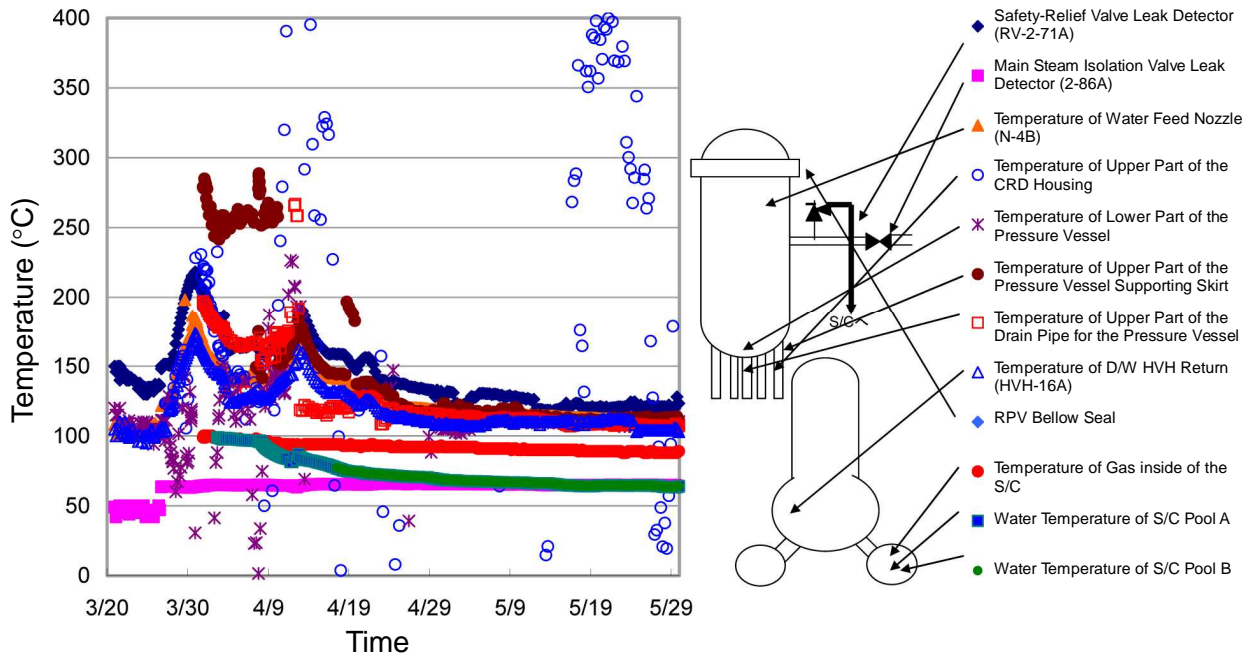

**Fig. 2.3-4c: Shift of Temperature (Unit 2: Long Term)**

## **2.4 Course of accident at Unit 3**

### **2.4.1 From occurrence of earthquake to arrival of tsunami**

Unit 3 was in constant thermal output operation at 2,381 WMt. Due to the earthquake, it automatically stalled at 14:47 on March 11 after receiving a 'large seismic acceleration' signal and all control rods were fully inserted into the reactor.

The earthquake damaged various systems including equipment in the New Fukushima Substation, causing power supply through Okuma No. 4 Line (Okuma No. 3 Line had been under construction and not used) to be lost. This resulted in total loss of external power supply to the Station. At 14:48, the power supply to the emergency bus conductors was lost. Two DGs for emergency use (3A and 3B) started operating immediately and automatically, and power supply to the emergency bus conductors was restored.

Loss of power supply to the emergency bus conductors caused loss of power supply for the nuclear reactor protection system, which resulted in automatic closure of MSIV. This surged pressure in the nuclear reactor, but the main steam relief valve (SRV) controlled the pressure.

The water level in the nuclear reactor was once lowered immediately after the nuclear reactor stopped automatically, due to a void collapse. However, after that the level was successfully controlled by RCIC without reaching the level that HPCI automatically starts (L-2: TAF+2,950 mm). The nuclear reactor remained stopped automatically after receiving the 'High Nuclear Reactor Water Level' signal at 15:25 on March 11.

As mentioned above, from the time the earthquake occurred to the arrival of the tsunami, the measures taken by the Station were those normally done when the external power supply is lost and there is a scram of a nuclear reactor.

### **2.4.2 From arrival of tsunami to hydrogen explosion of the reactor building**

The first tsunami arrived in about 41 minutes after the earthquake hit the area, i.e., 15:27 on March 11, followed by the second tsunami at 15:35. This caused inundation and submergion of the seawater pump for cooling and power supply panel. At 15:38 on the same day, both emergency DGs (3A and 3B) stopped and AC power supply was totally lost. Due to the Station Black Out, the RHR and the CS were unable to function. The Station determined at 15:42 on March 11 that the situation corresponded to an event applicable to Article 10 of the Act on Special Law of Emergency Preparedness for Nuclear Disaster, i.e., Station Black Out.

Due to the Station Black Out, only emergency lighting systems were available in MCR. The ventilation system in MCR also stopped. Unit 4, located next to Unit 3, was undergoing a regular inspection and all fuel rods were taken out of it. So, parameters such as water level in the nuclear reactor were checked centered on Unit 3, using a flashlight.

The DC power supply system in Unit 3 survived the inundation, and RCIC and the HPCI could be operated by DC power supply. To use the batteries as long as possible, all loads that were not immediately required were disconnected from them.

The RCIC was not in operation, then. As the water level in the nuclear reactor gradually decreased, it was manually run at 16:03 on March 11, to maintain the water level while monitoring the operation of the RCIC.

By 21:58 on the same day, a small power generator was installed in MCR and the temporary lighting system was restored.

From then, the water level in the nuclear reactor was maintained using RCIC. However, at 11:36 on March 12, the RCIC automatically stopped and the water level started falling again. It reached the low nuclear reactor water level (L-2: TAF+2,950 mm) at 12:35 on the same day. This automatically started HPCI.

This restored the water level in the nuclear reactor, which was maintained for a while thanks to the HPCI. At 2:42 on March 13, however, the HPCI automatically stopped, losing its water injection function to the nuclear reactor.

To reverse the situation, D/D-FP, an alternative water injection method for a severe accident was used, but in vain because the pressure inside the nuclear reactor surged to approximately 4.1 MPa [gage].

The workers tried to restart the HPCI and the RCIC, but failed to do so because the battery ran out. So the Station determined at 5:10 on March 13 that the situation corresponded to an event applicable to Article 15 of the Act on Special Law of Emergency Preparedness for Nuclear Disaster, i.e., loss of capacity to cool down a nuclear reactor.

The following explain how the alternative cooling water supply was used and how PCV ventilation was made.

#### Alternative Cooling Water Supply

The disaster countermeasures office in the Fukushima Daiichi Nuclear Power Station was examining the use of fire engine as an alternative way of injecting water into the nuclear reactor. Of the three fire engines held by the Station, one had already been used for injecting seawater into Unit 1, and the second one was unusable because of the tsunami. The remaining one, mobilized at the Unit 5 to 6 side was unable to be moved because the earthquake damaged the road and the tsunami left a lot of debris. So the roads in the Station's premises were restored urgently and the remaining third fire engine was successfully moved to the Unit 1 to 4 side.

Another fire engine was brought in from the Fukushima Daini Nuclear Power Station and an alternative system to inject water into the nuclear reactor using RHR from FP was constructed with the pumper as the driving source and a water tank for fire-protection (freshwater) as the water source.

In order to use the alternative water injection method, it was necessary to reduce the pressure inside the nuclear reactor so that it was lower than the output pressure of the pumper. For this purpose, batteries had to be collected to manually open the SRV, but all batteries in the Station had already been used for other purposes including restoration of measuring instruments of Units 1 and 2. So car batteries were collected from the cars of the plant workers that had been parked on high ground and thus survived the tsunami, to use them as the power source for the SRV.

The SRV was manually opened at 9:08 on March 13 and the pressure inside the nuclear reactor was rapidly reduced.

After the pressure in the nuclear reactor was reduced, the workers were able to inject water using the pumper. At 9:25 on the same day, the workers started to inject water into the reactor after dissolving boric acid in the freshwater in the water tank for fire-protection.

At 10:30 on the same day, the plant manager indicated he would consider using seawater as an alternative water source.

The water tank for fire-protection became empty at 12:20 on the same day. So, the workers altered the water injection system so that they could use seawater in the backwash valve pit. Use of seawater started at 13:12 on the same day.

In order to replenish seawater in the backwash valve pit, the Station requested to have some more fire engines. However, it took a long time before they arrived at the Station, partly because of the high radiation and contamination in the Station and partly because of the bad road conditions leading to the Station. For these reasons, the fire engines were unable to go directly to the Station but had to be handed over to the plant workers at such places as the Off Site Center and J-Village, and the people there then brought them to the Station. As the seawater in the backwash valve pit was about to run out, the pumper connected to the FP stopped once and was moved closer to the backwash valve pit at 1:10 on March 14. Then, after inserting the hose deeper into the pit, the workers started injecting seawater again at 3:20 on the same day.

The requested fire engines arrived at the Station early in the morning of March 14. The two fire engines were parked around the cargo unloading station to directly suck seawater from the sea and carry it to the backwash valve pit. Replenishment of seawater to the backwash valve pit from the cargo unloading station using the seawater sucking line started at 9:20 on the same day.

A total of 7 water trucks (each 5t) owned by the Self-Defense Forces arrived at the Station. They were set up at the backwash valve pit and the seawater started being replenished at 10:53 on the same day.

An explosion occurred at the R/B of Unit 3 at 11:01 on March 14, possibly a hydrogen gas explosion, which severely damaged the R/B and debris was scattered around the area.

The explosion damaged the fire engines and hoses used for injecting water to the nuclear reactor, and seawater injection stopped. The backwash valve pit became unusable due to the debris and seawater replenishment by the water trucks also stopped.

#### PCV Ventilation

After the plant manager instructed the workers to start preparing for PCV ventilation at 17:30 on March 12, procedures for the PCV ventilation were examined and locations of valves to be operated were confirmed.

At around 4:50 on March 13, in order to open the AO valve (large valve) on the ventilation line connected from the S/C, the solenoid valve of the AO valve was forcibly energized using a power source supplied by a small-sized power generator for temporary lighting in the central operating room.

At 5:15 on the same day, the plant manager instructed the workers to construct a PCV ventilation system, excluding a rupture disc. A worker checked the opening angle of the AO valve (large valve) in the torus room and found it was closed. So air cylinders supplying force to open and close the valve were replaced with new ones. As a result, the valve opened at 5:23 on March 23.

A press meeting was held to announce of starting a PCV ventilation at 5:50 on March 13 and results of radiation exposure evaluation to the areas neighboring the Station were notified to the relevant organizations at 7:35.

At 7:39 on the same day, the workers started spraying water to the PCVs using the line structure normally used when a severe accident has occurred, using D/D-FP, which was an alternative method of water injection.

Another MO valve on the PCV ventilation line was opened 15% manually on site, using the method stipulated in the procedure document at around 8:35 on the same day. At 8:41, a structure for PCV ventilation was completed, excluding rupture discs. At this point, however, the D/W pressure was lower than the working pressure of a rupture disc, i.e., 427 kPa [gage], and the workers continued monitoring the D/W pressure while keeping the valves on the PCV ventilation line open.

The D/W pressure kept increasing, thereafter. However, it started decreasing (from 0.637 MPa [abs] at 9:10 to 0.540 MPa [abs] at 9:24). So the Station determined that the PCV ventilation was done.

The pressure of cylinders installed at the AO valve (large valve) on the ventilation line connecting from S/C showed a decrease at around 9:28 on March 13. An investigation revealed that a leakage was found at the joints of the cylinders and the joints were additionally tightened. At 11:17 on the same day, the cylinder pressure fell causing the AO valve (large valve) to close. So the cylinders were replaced with new ones and the AO valve (large valve) was opened again at 12:30 on the same day. The workers were unable to perform work to keep the valve open because the conditions at the site were unfavorable.

At 14:15 on the same day, the MP indicated 905  $\mu\text{Sv/h}$  and the Station determined the situation corresponded to an event applicable to Article 15 of the Act on Special Law of Emergency Preparedness for Nuclear Disaster, i.e., abnormal surge of radiation dose at the boundary of the premise.

At around 14:31 on March 13, the radiation dose increased by more than 300 mSv/h at the north of the R/B double doors, and by 100 mSv/h at its southern side and inside the R/B filled with white smoke.

In the central operating room of Unit 3, the radiation dose showed an increase of 12 mSv/h at 15:28 on the same day, so the shift supervisor evacuated the workers to the central operating room on the Unit 4 side.

As the IA, the driving source of the AO valve (large valve) on the ventilation line from S/C was not in operation, the restoration team of the Station's disaster countermeasures office installed a tentative compressor at the service entrance for large items of the T/B and connected it to the IA system at around 17:52 on the same day.

The D/W pressure fell at around 20:10 on the same day, and the Station

determined that the AO valve (large valve) was open and the PCV ventilation was done.

The D/W pressure showed an upward trend at around 2:00 on March 14 (from 0.265 MPa [abs] at 2:00 to 0.315 MPa [abs] at 3:00 on March 14) and the Station decided to open another AO valve (small valve) on the ventilation line from S/C. At 3:40 on the same day, an operation to open the AO valve started by forcibly energizing the solenoid valve. The AO valve became open at 6:10. The radiation dose at the MP recorded 518.7  $\mu\text{Sv/h}$  at 9:12 on March 14 and the Station determined the situation corresponded to an event applicable to Article 15 of the Act on Special Law of Emergency Preparedness for Nuclear Disaster, i.e., abnormal surge of radiation dose at the boundary of the premise.

#### **2.4.3 After hydrogen gas explosion in the R/B**

An explosion, possibly of hydrogen gas, occurred at the R/B at 11:01 on March 14. It severely damaged the reactor building. All workers excluding workers at the central operating room stopped all their work and evacuated to the antiseismic building. All restoration work was suspended for a while to check the safety of workers, on-site condition and the safety of the site.

Due to debris generated by the explosion, the backwash valve pit was unable to be used. Fire engines were moved to the area around the cargo unloading station and hoses were relaid to take seawater directly from the sea to inject water to the nuclear reactor. Additionally, two fire engines were connected serially, to form a water feeding system to both Unit 2 and Unit 3. Seawater injection restarted at around 16:30 on March 14.

On the other hand, for the PCV ventilation, it was difficult to energize the solenoid valves on the air feed line while maintaining air pressure to drive the AO valve to keep the AO valves on the ventilation line (small and large valves). An AO valve, even if it was opened, closed instantly. So, for a while the workers repeated an operation to open the valves a number of times.

AO Valve (large valve)

Mar. 15 at 16:00: Closing confirmed	→	Mar. 15 at 16:05: Opening operation
Mar. 17 at 21:00: Closing confirmed	→	Mar. 17 at around 21:30: Opening operation
Mar. 18 at 5:30: Closing confirmed	→	Mar. 18 at around 5:30: Opening operation
Mar. 19 at 11:30: Closing confirmed	→	Mar. 20 at around 11:25: Opening operation

AO Valve (small valve)

Mar. 15 at 16:00: Closing confirmed	→	Mar. 16 at 1:55: Opening operation
-------------------------------------	---	------------------------------------

#### **2.4.4 Major events thereafter**

To restore power supply to the Station, the workers repaired the transformers in the New Fukushima Substation and performed bypassing work between the Yonomori Line 1 and the Okuma Line 3. On March 18, recharging was completed up to the portable M/C installed in the plant premises. Lighting in the

central operating room was restored on March 22.

To build an alternative water injection to the nuclear reactor, the workers switched the water source to freshwater supplied from deionized water tanks on March 25. The water source was further changed to a temporary electric motor pump driven by fire engines on March 28. From April 3 onward, the power source to the temporary electric motor pump was switched from a temporary power source to regular power lines.

#### **2.4.5 Condition of spent fuel pool**

As of March 11, 514 spent fuel rods and 58 new fuel rods were stored in the spent fuel pool (SFP) of Unit 3. The Station estimated the decay heat generated by these fuel rods in the SFP was approximately 0.54 MWt (as of March 11).

The earthquake that occurred at 14:46 on March 11 caused a total loss of external power supply to the plant, and the FPC came to a halt. The massive tsunami that hit the plant after the earthquake caused Station Blackout and the functions of cooling and supplying water to the SFP were lost.

The explosion of the R/B of Unit 3 that occurred at 11:01 on March 14 caused a massive amount of debris on the SFP.

Seawater was dropped on the R/B using helicopters at around 9:48 on March 17 and generation of steam from the R/B was confirmed. The workers shot water from water canon trucks starting from 19:05 on the same day. They repeated the water shooting till March 25 using water canon trucks and tower water canon vehicles (in most cases using seawater).

From March 27 onward, they used concrete pump trucks for water shooting. The type of water was switched from seawater to freshwater on March 29.

The Station considers that these water injections were successful in keeping the water level in the SFP sufficiently high to prevent the fuel rods from being exposed to the air.

**Table 2.4-1 Time-Course Progress (Unit 3)**

March 11, 2011 (Fri.)	
14:46	Great East Japan Earthquake occurs. Alert Level 3 automatically issued.
14:47	Scram of nuclear reactors occurs automatically and main turbine manually stops.
Around 14:48	Emergency DG automatically activated.
14:54	Subcriticality of the nuclear reactor confirmed.
15:05	RCIC manually started.
15:06	A disaster countermeasures office established in the TEPCO head office. (to understand the damage conditions due to the earthquake and restoration from blackout)
15:25	RCIC trips (due to high water level in the nuclear reactor).
15:27	First tsunami arrives.
15:35	Second tsunami arrives.
15:38	Station Blackout occurs.
15:42	The Station determined the situation corresponds to a special event applicable to Paragraph 1, Article 10 of the Act on Special Law of Emergency Preparedness for Nuclear Disaster (Station Blackout). Notified the same to governmental agencies and other relevant organizations.
15:42	Alert Level 1 issued. An emergency task force established (as joint headquarters with disaster countermeasures office).
16:03	RCIC manually started.
16:36	Alert Level 2 issued.
20:50	Fukushima Prefecture directs local residents living within a 2 km radius from the Fukushima Daiichi Nuclear Power Station to evacuate.
21:23	The Prime Minister directs local residents living within a 3 km radius from the power plant to evacuate and those living within a 3 km to 10 km radius to stay indoors.
21:58	Temporary lighting in MCR turns ON.
March 12, 2011 (Sat.)	
0:30	Completion of evacuation of the local residents confirmed by the Government of Japan (confirmed evacuation of people living within 3 km from the plant in Futaba City and Okuma City, and reconfirmed it at 1:45).
4:55	Confirmed surge of radiation dose within the plant premises surges (around the main gate: 0.069 $\mu$ Sv/h (at 4:00) $\rightarrow$ 0.59 $\mu$ Sv/h (at 4:23)). The same is notified to governmental agencies and other relevant organizations.
5:44	The Prime Minister directs local residents living within a 10 km radius from Fukushima Daiichi Nuclear Power Station to evacuate.
7:11	The Prime Minister arrives at the Fukushima Daiichi Nuclear Power Station.
8:04	The Prime Minister leaves the Fukushima Daiichi Nuclear Power Station.
11:36	RCIC trips.
12:35	HPCI automatically runs (due to low water level in the nuclear reactor)
17:30	The plant manager instructs the workers to start preparing for PCV ventilation.
18:25	The Prime Minister directs local residents living within a 20 km radius from the Fukushima Daiichi Nuclear Power Station to evacuate.

March 13, 2011 (Sun.)

- 2:42 HPCI stops.
- 5:10 Water injection using RCIC is failed so the Station determines that a special event applicable to Paragraph 1, Article 15 of the Act on Special Law of Emergency Preparedness for Nuclear Disaster has occurred (nuclear reactor cooling function lost). The same is notified to governmental agencies and other relevant organizations at 5:58.
- 5:15 The plant manager instructs the workers to complete the ventilation line up excluding a rupture disc.
- 5:50 Held a press meeting on initiation of PCV ventilation.
- 6:19 Determined at 4:15 as TAF has been reached. The same is notified to governmental agencies and other relevant organizations.
- 7:35 Notified governmental agencies and other relevant organizations of the result of radiation exposure evaluation to be released when PCV ventilation is done.
- 7:39 Started spraying PCVs. The same is notified to governmental agencies and other relevant organizations at 7:56.
- 8:35 Ventilation valves (MO valves) of PCVs opened.
- 8:41 After opening the large valve of the S/C ventilation valves (AO valves), the ventilation line is completed, excluding a rupture disc. The same is notified to governmental agencies and other relevant organizations at 8:46.
- 8:56 A radiation dose of over 500  $\mu\text{Sv/h}$  at the MP i.e., 882  $\mu\text{Sv/h}$  observed and the Station determines that a special event applicable to Paragraph 1, Article 15 of the Act on Special Law of Emergency Preparedness for Nuclear Disaster has occurred (abnormal surge of radiation dose at the boundary of the premises). The same is notified to governmental agencies and other relevant organizations at 9:01.
- Around 9:08 Safety-relief valves used for rapid release of pressure in the nuclear reactor. Notified the governmental agencies and other relevant organizations at 9:20 that from then onward water would be injected into the nuclear reactor using the FP line.
- 9:25 Started fresh water injection (with boric acid) from the FP line to the nuclear reactor using fire engines.
- 9:36 The ventilation operation confirms that the D/W pressure is being decreased from around 9:20. The Station notifies the governmental agencies and other relevant organizations that it has started injecting water into the nuclear reactor using the FP line.
- 10:30 The plant manager announces that the Station may use seawater injection as an option.
- 11:00 The Prime Minister directs local residents living within a 20 km to 30 km radius from the Fukushima Daiichi Nuclear Power Station to stay indoors.
- 11:17 Confirmed a large valve of the S/C ventilation valve (AO valve) is closed (due to a decreased working air cylinder pressure).
- 12:20 Completed freshwater injection.
- 12:30 A large valve of the S/C ventilation valve (AO valve) opens. (Replaced the working air cylinders.)
- 13:12 Seawater injection to the nuclear reactor starts from the FP line using fire engines.
- 14:15 A radiation dose of over 500  $\mu\text{Sv/h}$  at the MP i.e., 905  $\mu\text{Sv/h}$  observed

and the Station determines that a special event applicable to Paragraph 1, Article 15 of the Act on Special Law of Emergency Preparedness for Nuclear Disaster has occurred (abnormal surge of radiation dose at the boundary of the premises). The same is notified to governmental agencies and other relevant organizations at 14:23.

March 14, 2011 (Mon.)

- 1:10 Seawater in the pit to feed to the nuclear reactor is running out. Stopped the fire engines for replenishing seawater into the backwash valve pit.
- 2:20 A radiation dose of over 500  $\mu\text{Sv/h}$  at around the main gate i.e., 751  $\mu\text{Sv/h}$  observed and the Station determines that a special event applicable to Paragraph 1, Article 15 of the Act on Special Law of Emergency Preparedness for Nuclear Disaster has occurred (abnormal surge of radiation dose at the boundary of the premises). The same is notified to governmental agencies and other relevant organizations at 4:24.
- 2:40 A radiation dose of over 500  $\mu\text{Sv/h}$  at the MP i.e., 650  $\mu\text{Sv/h}$  observed and the Station determines that a special event applicable to Paragraph 1, Article 15 of the Act on Special Law of Emergency Preparedness for Nuclear Disaster has occurred (abnormal surge of radiation dose at the boundary of the premises). The same is notified to governmental agencies and other relevant organizations at 5:37.
- 3:20 Seawater injection using the fire engines resumes.
- 4:00 A radiation dose of over 500  $\mu\text{Sv/h}$  at the MP i.e., 820  $\mu\text{Sv/h}$  observed and the Station determines that a special event applicable to Paragraph 1, Article 15 of the Act on Special Law of Emergency Preparedness for Nuclear Disaster has occurred (abnormal surge of radiation dose at the boundary of the premises). The same is notified to governmental agencies and other relevant organizations at 8:00.
- 5:20 Starts opening operation of a small valve of the S/C ventilation valve (AO valve).
- 6:10 Confirmed that the S/C ventilation valve (AO valve) is open.
- 9:12 A radiation dose of over 500  $\mu\text{Sv/h}$  at the MP i.e., 518.7  $\mu\text{Sv/h}$  observed and the Station determines that a special event applicable to Paragraph 1, Article 15 of the Act on Special Law of Emergency Preparedness for Nuclear Disaster has occurred (abnormal surge of radiation dose at the boundary of the premises). The same is notified to governmental agencies and other relevant organizations at 9:34.
- 9:20 Started replenishing seawater from the cargo unloading station to the backwash valve pit.
- 11:01 An explosion occurs in R/B, damaging the fire engines and hoses. Stopped seawater injection.
- Around 16:30 Constructed a new line that feeds seawater from the cargo unloading station to the nuclear reactor. Replaced the damaged fire engines and hoses with new ones.
- 21:35 A monitoring car recorded a radiation dose of over 500  $\mu\text{Sv/h}$  at the MP i.e., 760  $\mu\text{Sv/h}$  and the Station determines that a special event applicable to Paragraph 1, Article 15 of the Act on Special Law of Emergency Preparedness for Nuclear Disaster has occurred (abnormal surge of radiation dose at the boundary of the premises). The same is notified to governmental agencies and other relevant organizations at 22:35.

March 15, 2011 (Tue.)

- 6:50 A radiation dose of over 500  $\mu\text{Sv/h}$  around the main gate i.e., 583.7  $\mu\text{Sv/h}$  observed and the Station determines that a special event applicable to Paragraph 1, Article 15 of the Act on Special Law of Emergency Preparedness for Nuclear Disaster has occurred (abnormal surge of radiation dose at the boundary of the premises). The same is notified to governmental agencies and other relevant organizations at 7:00.
- 7:00 Notified the governmental agencies and other relevant organizations that all workers except for monitoring staff and other workers required for restoration of the Station would evacuate to Fukushima Daini Nuclear Power Station.
- 7:55 Confirmed steam floating above the R/B. The same is notified to governmental agencies and other relevant organizations.
- 8:11 A radiation dose of over 500  $\mu\text{Sv/h}$  around the main gate i.e., 807  $\mu\text{Sv/h}$  observed and the Station determines that a special event applicable to Paragraph 1, Article 15 of the Act on Special Law of Emergency Preparedness for Nuclear Disaster has occurred (abnormal release of radioactive substances due to a fire and an explosion). The same is notified to governmental agencies and other relevant organizations at 8:36.
- 16:00 A radiation dose of over 500  $\mu\text{Sv/h}$  at the main gate i.e., 531.6  $\mu\text{Sv/h}$  observed and the Station determines that a special event applicable to Paragraph 1, Article 15 of the Act on Special Law of Emergency Preparedness for Nuclear Disaster has occurred (abnormal surge of radiation dose at the boundary of the premises). The same is notified to governmental agencies and other relevant organizations at 16:22.
- 23:05 A radiation dose of over 500  $\mu\text{Sv/h}$  around the main gate i.e., 4,548  $\mu\text{Sv/h}$  observed and the Station determines that a special event applicable to Paragraph 1, Article 15 of the Act on Special Law of Emergency Preparedness for Nuclear Disaster has occurred (abnormal release of radioactive substances due to a fire and an explosion). The same is notified to governmental agencies and other relevant organizations at 23:20.

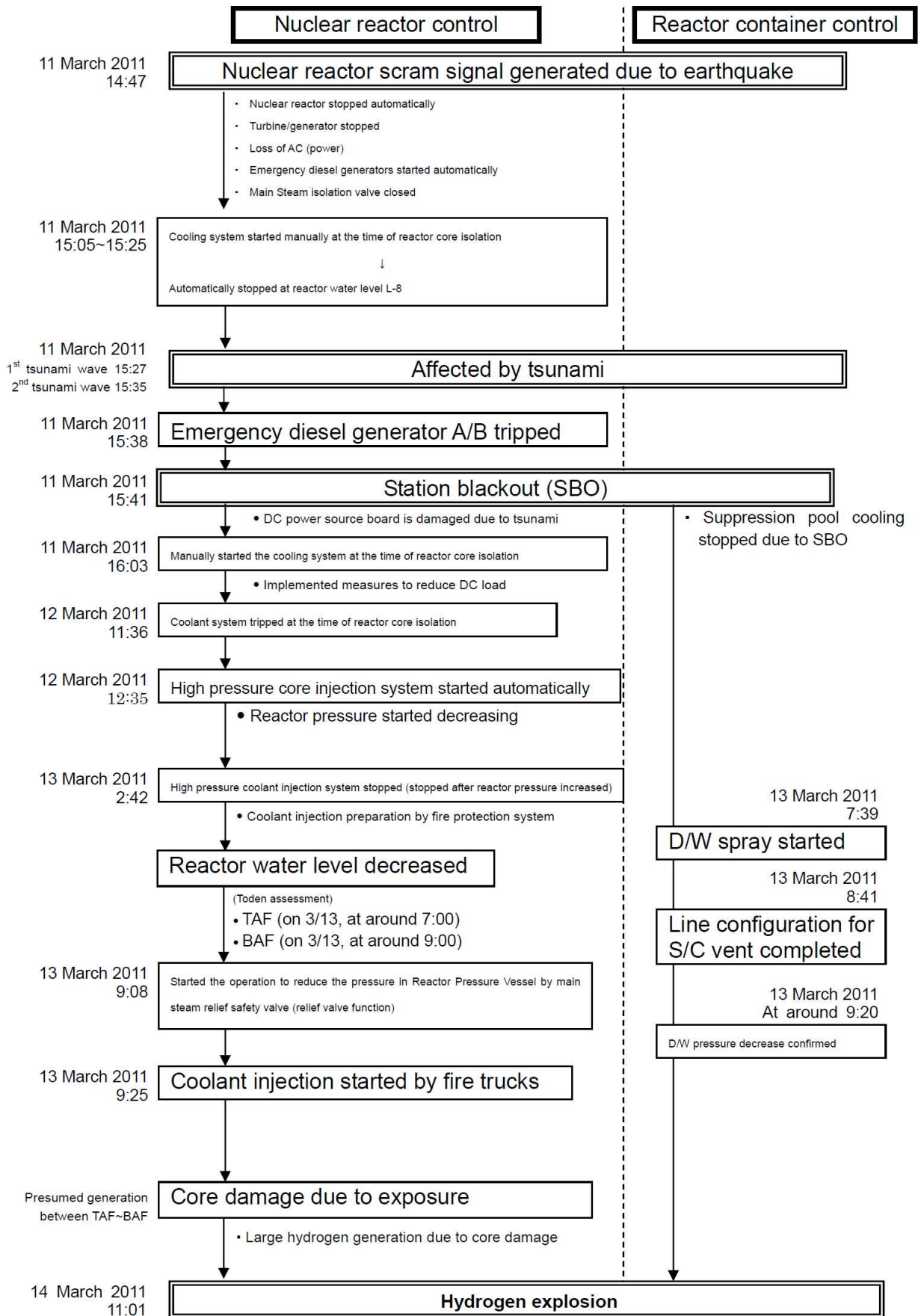

**Fig. 2.4-1: Fukushima Daiichi Nuclear Power Station Unit 3 accident progress flow after the earthquake**

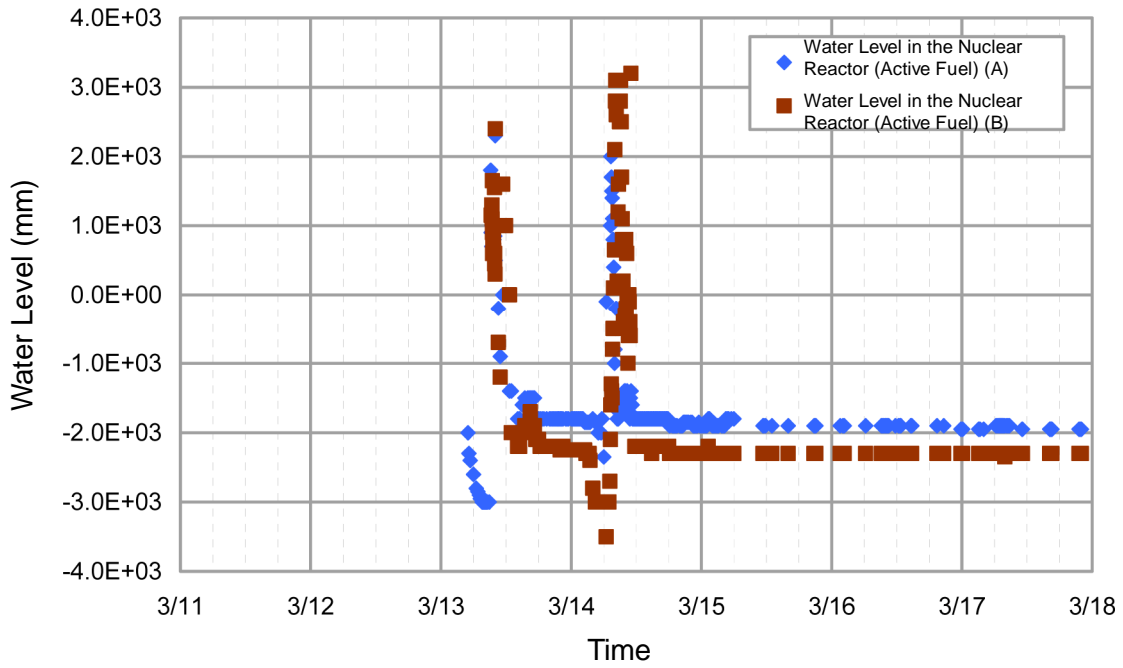

**Fig. 2.4-2a: Shift of the Water Level in the Nuclear Reactor (Unit 3)**

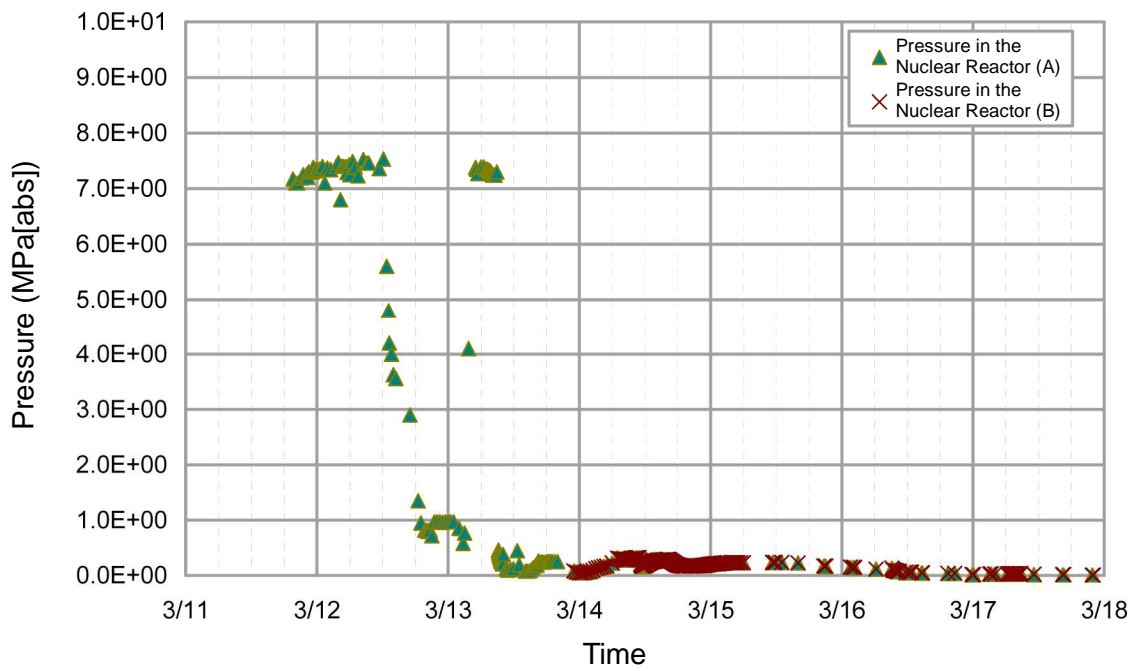

**Fig. 2.4-2b: Shift of Pressure in the Nuclear Reactor (Unit 3)**

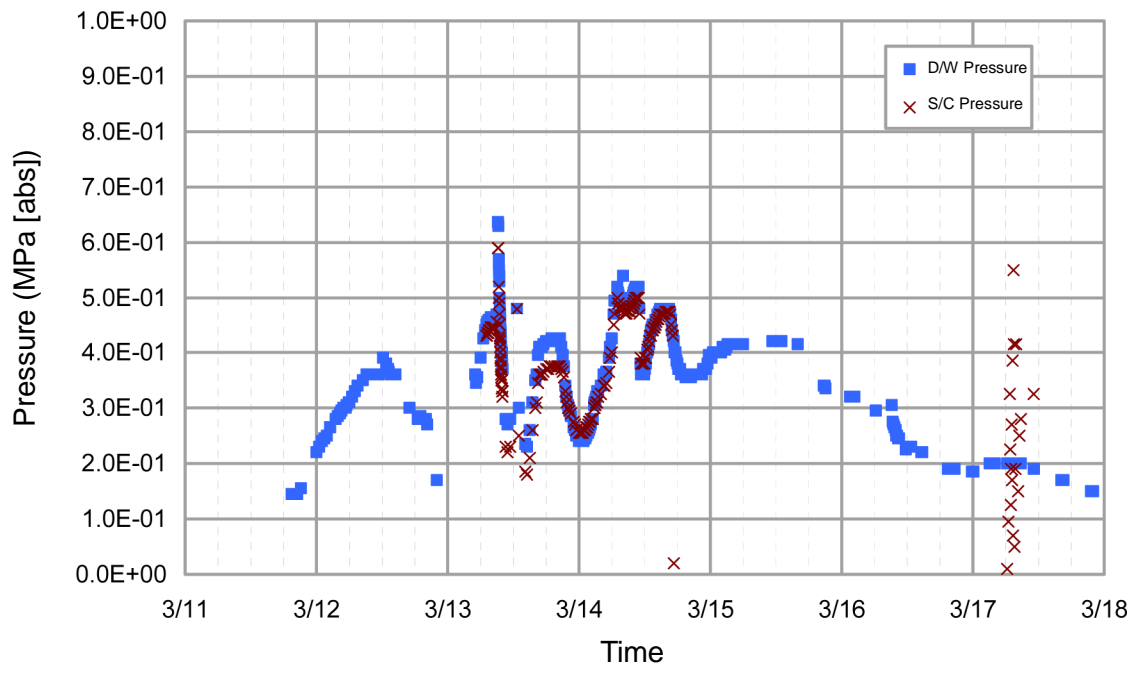

**Fig. 2.4-2c: Shift of the Pressure in the Primary Containment Vessel (Unit 3)**

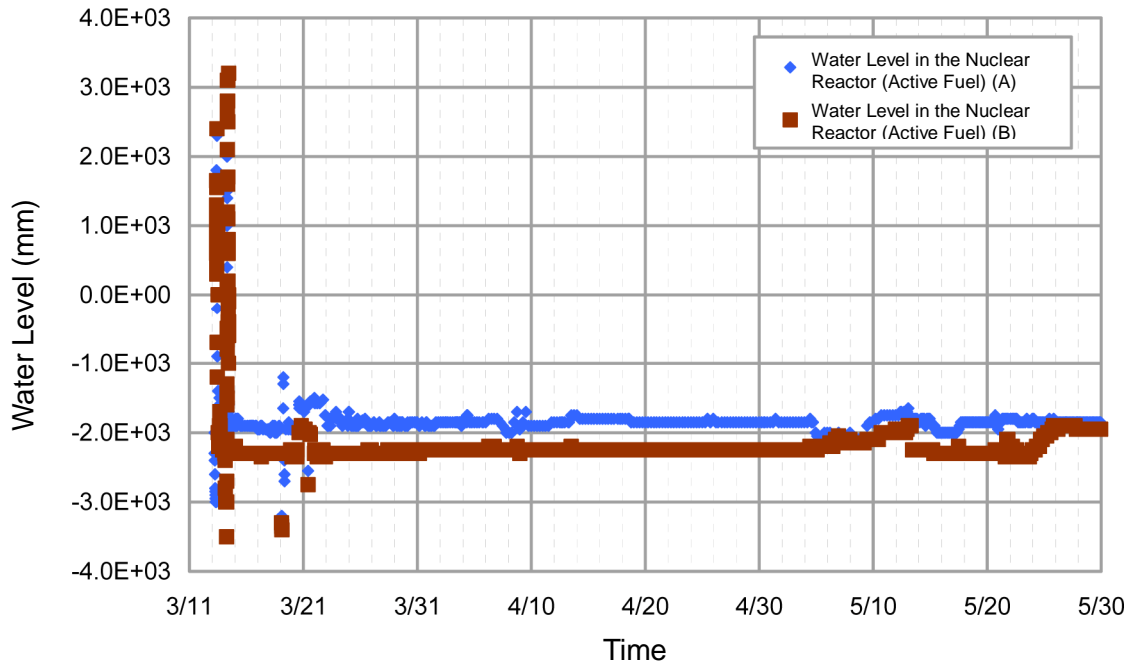

**Fig. 2.4-3a: Shift of the Water Level in the Nuclear Reactor (Unit 3: Long Term)**

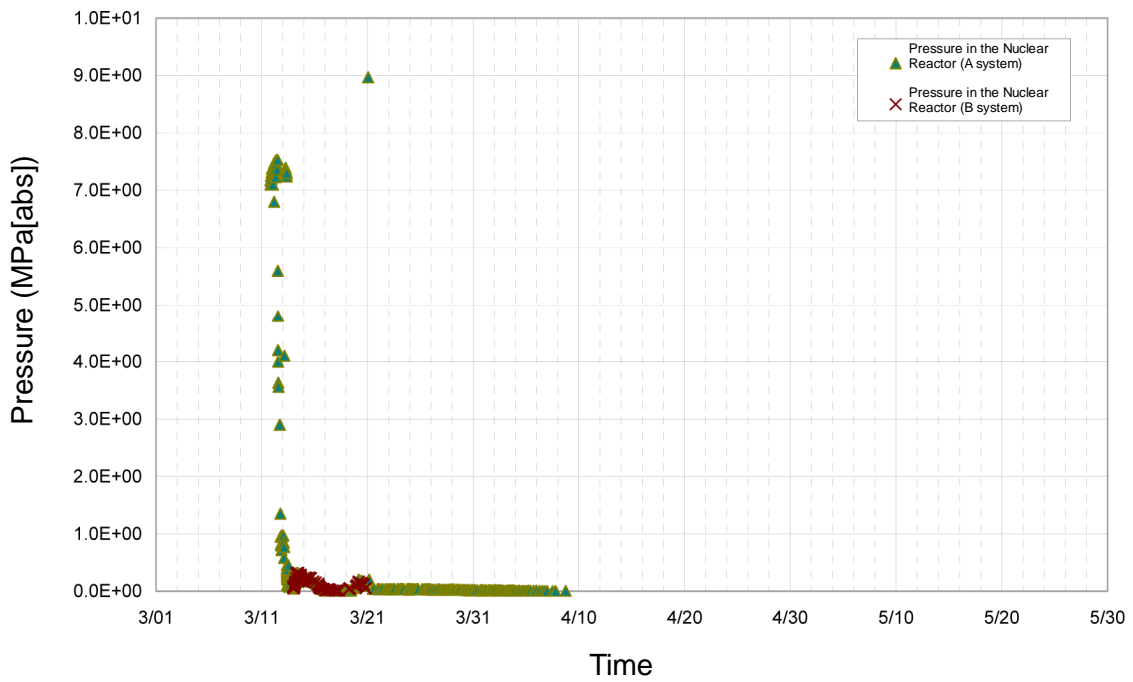

**Fig. 2.4-3b: Shift of Pressure in the Nuclear Reactor (Unit 3: Long Term)**

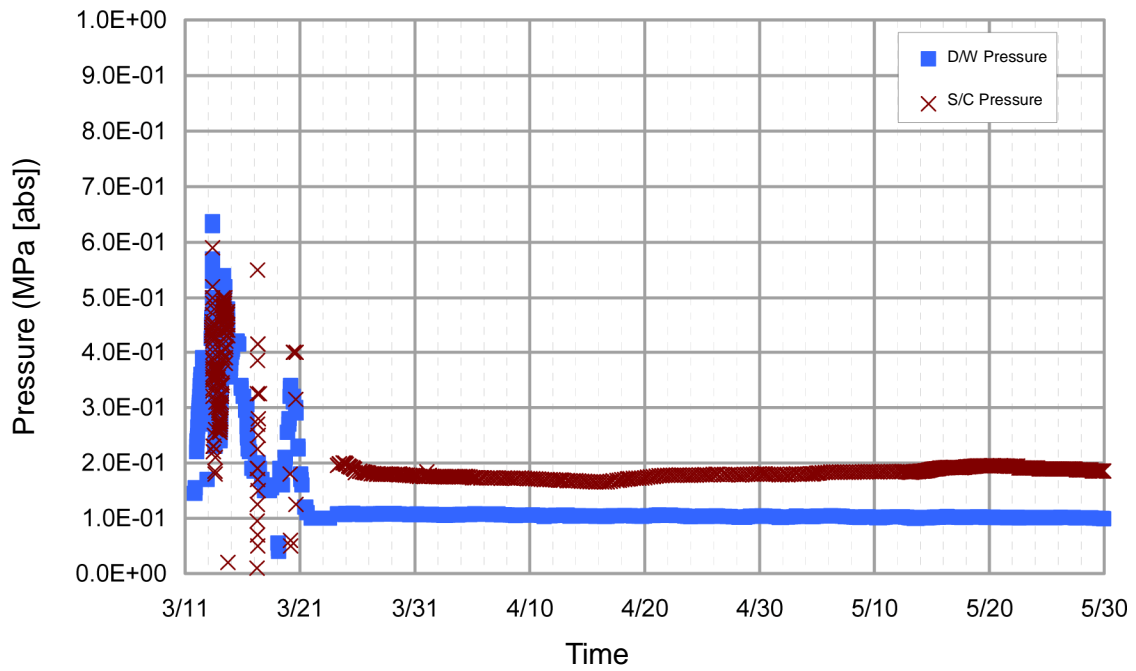

**Fig. 2.4-3c: Shift of the Pressure in the Primary Containment Vessel (Unit 3: Long Term)**

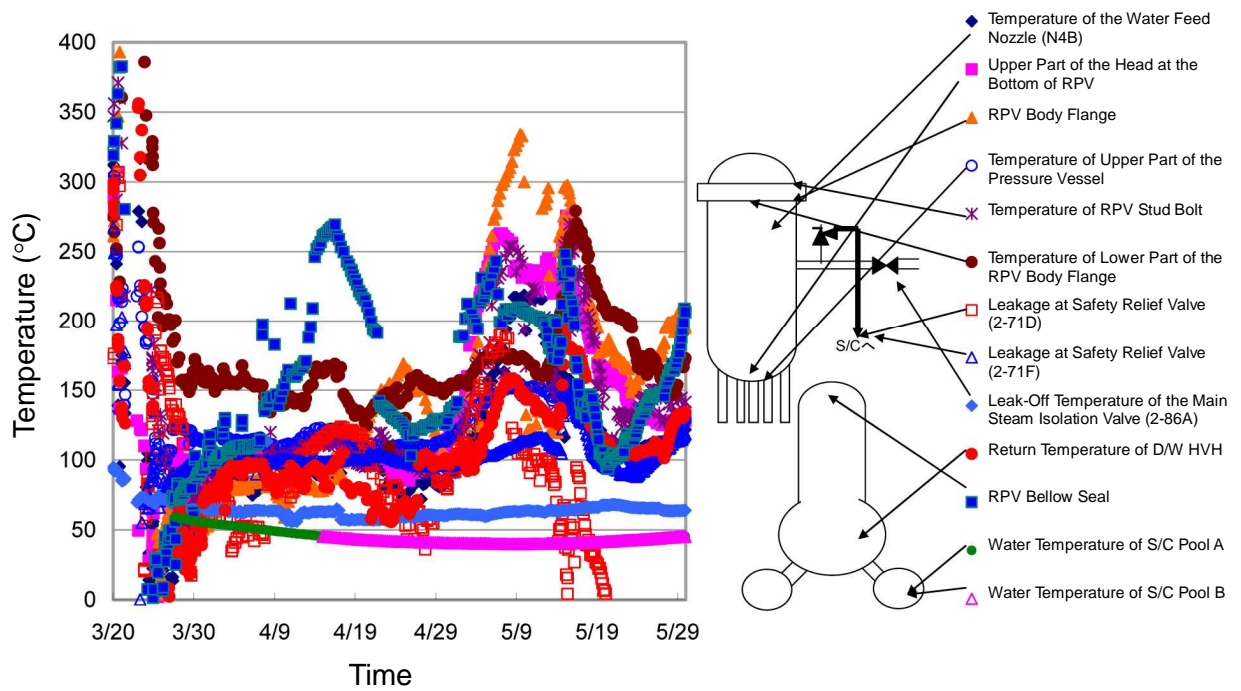

**Fig. 2.4-4c: Shift of Temperature (Unit 3: Long Term)**

## 2.5 Course of accident at Unit 4

Unit 4 had been undergoing a regular inspection since November 30, 2010 and all fuel rods had been taken out of the nuclear reactor to its SFP to replace its shroud. A total of 1,535 fuel rods (97% of the total storage capacity) were in the SFP and their decay heat was relatively high (decay heat: approximately 2.26 MWt as of March 11).

The water level in the SFP was around the overflow level and the temperature was approximately 27°C. On the nuclear reactor side, the pool gate was closed and filled with water.

The earthquake that occurred at around 14:47 on March 11 damaged various systems including equipment in the New Fukushima Substation, causing a total loss of external power supply. However, a stand-by emergency DG automatically started (another DG was undergoing a regular inspection) and the necessary power supply to the system was secured.

The massive tsunami that hit the plant at 15:38 on March 11 made the emergency DG stop and a Station Black Out occurred. This made it impossible to cool down the SFP. Temporary lighting equipment only was available in the central operating room.

After restoration work by the restoration team of the Station's disaster countermeasures office, a small-sized power generator was installed in the central operating room and a temporary lighting system became available at 21:58 on the same day.

Then, the water temperature in the SFP reached to 84°C at 4:08 on March 14.

A very loud sound was heard at around 6:00 on March 15. Damage was found to the roof of the 5th Floor of the R/B of Unit 4. In addition, at 9:38 on March 15, a fire was observed around the northwestern corner on the 3rd Floor of the R/B. An on-site investigation started at around 11:00 on the same day, but the fire had already been automatically extinguished.

Workers onboard a helicopter of the Self-Defense Forces made an approach to its operating floor on March 16. They visually noted the water surface of the spent fuel pool and confirmed that fuel rods in it were not exposed.

Water injection by the Self-Defense Forces and by a high-pressure water canon owned by the U.S. forces was carried out on March 20 and March 21 respectively. Another water injection started on March 22 using a concrete pumper.

The workers investigated the R/B, and found that its 5th Floor and western and eastern sides on the 4th Floor were seriously damaged. The Station estimated that hydrogen was present around the 4th and 5th Floors. Water was sampled from the pool. From the fact that only a small amount of radioactive substance was contained in it as well as from the result of observations via underground photography, the Station considered that most fuel rods were intact. Therefore, there was only a small possibility that the fuels in the SFP had heated up and generated hydrogen.

In addition, the Station assumed that the water level in the SFP had been maintained in a way that any fall in the water level due to evaporation was being supplemented by water on the well side poured into the SFP by way of the gate, and this prevented the fuel rods from being exposed.

A pipe for the Standby Gas Treatment System (hereafter called "SGTS") of Unit 4 joins together with that of Unit 3 just before the exhaust pipe. The Station therefore points out that the flow of gas ventilated from Unit 3 might have flowed into Unit 4 through the SGTS pipes.

**Table 2.5-1 Time-Course Progress (Unit 4)**

March 11, 2011 (Fri.)

- 14:46 Great East Japan Earthquake occurs. Alert Level 3 automatically issued.
- 15:06 A disaster countermeasures office established in the TEPCO head office (to understand damage conditions due to the earthquake and restoration from blackout).
- 15:27 First tsunami arrives.
- 15:35 Second tsunami arrives.
- 15:38 Station Black Out occurs to Unit 4.
- 15:42 The Station determines that a special event applicable to Paragraph 1, Article 10 of the Act on Special Law of Emergency Preparedness for Nuclear Disaster has occurred (Station Black Out) to Unit 1\*, Unit 2\*, Unit 3\*, Unit 4\* and Unit 5\*. The same is notified to governmental agencies and other relevant organizations.
- \* Corrected on April 24, 2011. The Station Black Out occurred at Unit 1, 2 and 3 only.
- 15:42 Alert Level 1 issued. An emergency task force established (as joint headquarters with the disaster countermeasures office).
- 16:36 Alert Level 2 issued.
- 20:50 Fukushima Prefecture directs local residents living within a 2 km radius from the Fukushima Daiichi Nuclear Power Station to evacuate.
- 21:23 The Prime Minister directs local residents living within a 3 km radius from the power plant to evacuate and those living within a 3 km to 10 km radius to stay indoors.

March 12, 2011 (Sat.)

- 0:30 Completion of evacuation of the local residents confirmed by the Government of Japan (confirmed evacuation of people living within 3 km from the plant in Futaba City and Okuma City, and reconfirmed it at 1:45).
- 4:55 Development of radiation dose within the plant premises is confirmed. The same is reported to the governmental agencies and other relevant organizations.
- 5:44 The Prime Minister directs local residents living within a 10 km radius from Fukushima Daiichi Nuclear Power Station to evacuate.
- 7:11 The Prime Minister arrives at the Fukushima Daiichi Nuclear Power Station.
- 8:04 The Prime Minister leaves the Fukushima Daiichi Nuclear Power Station.
- 16:27 A radiation dose of over 500  $\mu\text{Sv/h}$  at the MP i.e., 1,015  $\mu\text{Sv/h}$  observed and the Station determines that a special event applicable to Paragraph 1, Article 15 of the Act on Special Law of Emergency Preparedness for Nuclear Disaster has occurred (abnormal surge of radiation dose at the boundary of the premises). The same is notified to governmental agencies and other relevant organizations.
- 18:25 The Prime Minister directs local residents living within a 20 km radius from the Fukushima Daiichi Nuclear Power Station to evacuate.

March 13, 2011 (Sun.)

- 8:56 A radiation dose of over 500  $\mu\text{Sv/h}$  at the MP i.e., 882  $\mu\text{Sv/h}$  observed and the Station determines that a special event applicable to Paragraph 1, Article 15 of the Act on Special Law of Emergency Preparedness for Nuclear Disaster has occurred (abnormal surge of radiation dose at the

boundary of the premises). The same is notified to governmental agencies and other relevant organizations at 9:01.

14:15 A radiation dose of over 500  $\mu\text{Sv/h}$  at the MP i.e., 905  $\mu\text{Sv/h}$  observed and the Station determines that a special event applicable to Paragraph 1, Article 15 of the Act on Special Law of Emergency Preparedness for Nuclear Disaster has occurred (abnormal surge of radiation dose at the boundary of the premises). The same is notified to governmental agencies and other relevant organizations at 14:23.

March 14, 2011 (Mon.)

2:20 A radiation dose of over 500  $\mu\text{Sv/h}$  at around the main gate i.e., 751  $\mu\text{Sv/h}$  observed and the Station determines that a special event applicable to Paragraph 1, Article 15 of the Act on Special Law of Emergency Preparedness for Nuclear Disaster has occurred (abnormal surge of radiation dose at the boundary of the premises). The same is notified to governmental agencies and other relevant organizations at 4:24.

2:40 A radiation dose of over 500  $\mu\text{Sv/h}$  at the MP i.e., 650  $\mu\text{Sv/h}$  observed and the Station determines that a special event applicable to Paragraph 1, Article 15 of the Act on Special Law of Emergency Preparedness for Nuclear Disaster has occurred (abnormal surge of radiation dose at the boundary of the premises). The same is notified to governmental agencies and other relevant organizations at 5:37.

4:00 A radiation dose of over 500  $\mu\text{Sv/h}$  at the MP i.e., 820  $\mu\text{Sv/h}$  observed and the Station determines that a special event applicable to Paragraph 1, Article 15 of the Act on Special Law of Emergency Preparedness for Nuclear Disaster has occurred (abnormal surge of radiation dose at the boundary of the premises). The same is notified to governmental agencies and other relevant organizations at 8:00.

4:08 Temperature in the SFP of Unit 4 is confirmed as 84°C.

9:12 A radiation dose of over 500  $\mu\text{Sv/h}$  at the MP i.e., 518.7  $\mu\text{Sv/h}$  observed and the Station determines that a special event applicable to Paragraph 1, Article 15 of the Act on Special Law of Emergency Preparedness for Nuclear Disaster has occurred (abnormal surge of radiation dose at the boundary of the premises). The same is notified to governmental agencies and other relevant organizations at 9:34.

21:35 A monitoring car recorded radiation dose of over 500  $\mu\text{Sv/h}$  at the MP i.e., 760  $\mu\text{Sv/h}$  and the Station determines that a special event applicable to Paragraph 1, Article 15 of the Act on Special Law of Emergency Preparedness for Nuclear Disaster has occurred (abnormal surge of radiation dose at the boundary of the premises). The same is notified to governmental agencies and other relevant organizations at 22:35.

March 15, 2011 (Tue.)

Around 6:00 to 6:10

A large sound is heard. Damage to around the roof of the 5th Floor of Unit 4 R/B is confirmed.

6:50 A radiation dose of over 500  $\mu\text{Sv/h}$  around the main gate i.e., 583.7  $\mu\text{Sv/h}$  observed and the Station determines that a special event applicable to Paragraph 1, Article 15 of the Act on Special Law of Emergency Preparedness for Nuclear Disaster has occurred (abnormal surge of radiation dose at the boundary of the premises). The same is notified to the

- governmental agencies and other relevant organizations at 7:00.
- 7:55 The Station notifies the governmental agencies and other relevant organizations that it has confirmed damage around the roof of the 5th Floor of Unit 4 R/B.
- 8:11 Damage to the Unit 4 R/B is confirmed. A radiation dose of over 500  $\mu\text{Sv/h}$  around the main gate i.e., 807  $\mu\text{Sv/h}$  observed and the Station determines that a special event applicable to Paragraph 1, Article 15 of the Act on Special Law of Emergency Preparedness for Nuclear Disaster has occurred (abnormal release of radioactive substances due to a fire and an explosion). The same is notified to governmental agencies and other relevant organizations at 8:36.
- 9:38 A fire is confirmed around the northwestern corner on the 3rd Floor of the Unit 4 R/B. The same is notified to the governmental agencies and other relevant organizations at 9:56.
- Around 11:00 Workers of TEPCO makes an on-site investigation of the fire that occurred at Unit 4 R/B, but they confirm that the fire has been automatically extinguished. The same is notified to the governmental agencies and other relevant organizations at 11:45.
- 16:00 A radiation dose of over 500  $\mu\text{Sv/h}$  at the main gate i.e., 531.6  $\mu\text{Sv/h}$  observed and the Station determines that a special event applicable to Paragraph 1, Article 15 of the Act on Special Law of Emergency Preparedness for Nuclear Disaster has occurred (abnormal surge of radiation dose at the boundary of the premises). The same is notified to governmental agencies and other relevant organizations at 16:22.
- 23:05 A radiation dose of over 500  $\mu\text{Sv/h}$  around the main gate i.e., 4,548  $\mu\text{Sv/h}$  observed and the Station determines that a special event applicable to Paragraph 1, Article 15 of the Act on Special Law of Emergency Preparedness for Nuclear Disaster has occurred (abnormal release of radioactive substances due to a fire and an explosion). The same is notified to governmental agencies and other relevant organizations at 23:20.

## 2.6 Course of accident at Unit 5

Unit 5 had been suspended since January 3, 2011 due to a periodic inspection. When the earthquake occurred, the reactor was loaded with fuel, and pressure leak tests of the RPV were being conducted with the control rod fully inserted. (RPV was full of water, and pressure of the nuclear reactor was approximately 7M Pa [gage], and temperature of the nuclear reactor was approximately 90°C). The water level of the SFP was full (around the overflow level), and water temperature of the pool was 24°C.

At 14:47 on March 11, the collapse of the steel towers of Yorunomori transmission line due to the earthquake caused a loss of external power supply, which automatically activated two emergency DGs.

After the earthquake occurred, the CRD pump that had been applying pressure on the reactor for the pressure leak test stopped due to a loss of power supply, leading to a temporary pressure drop in the reactor. In addition, although operation of the spent fuel cooling and filtering system pump also stopped as a result of the loss of power of external power supply, the RHR was put into standby state as the water temperature of the pool was sufficiently low and time was not pressing.

Then, the two emergency DGs stopped at 15:40 on March 11 due to the huge tsunami, resulting in the station blackout. As a result of this, the RHR and CS pumps became inoperable.

In the central operating room on the side of Unit 5 only temporary emergency lighting was available, which then went out. However, some of the monitoring instruments could be checked thanks to the DC power supply even after the Station Blackout.

As the pressure of the reactor increased due to decay heat, the workers attempted to reduce the pressure using the RCIC steam line and such like, but no change occurred. Around 1:40 on March 12, the SRV repeated automatic opening and closing operations by the safety valve function, and the pressure of the reactor was maintained at around 8 MPa [gage]. (The maximum operating pressure was 8.27 MPa [gage]).

At 6:06 on March 12, the workers opened the vent valve on top of the RPV to reduce the pressure of the RPV.

One emergency DG of Unit 6 was operating. Thus, at 8:13 on March 12, the workers utilized the power interchange cable to Unit 5, which had been laid as a countermeasure against severe accidents, and supplied electricity to part of the low voltage power panel of the R/B of Unit 5 from the emergency DG of Unit 6. In this way, they secured a power supply for instruments and such like. At 18:29 on March 13, they laid a temporary cable from the low voltage distribution board of Unit 6 and the MUWC pump was manually started at 20:54 on March 13.

In the early hours of March 14, the SRV was restored so that it could be operated from the central operating room. After 5:00 on March 14, the workers reduced the pressure with the SRV as appropriate, and the pressure of the reactor was maintained at 2 MPa [gage] or lower. In addition, by using the alternative water injection line installed as a countermeasure against severe accidents, the workers started injecting water into the reactor from the CST by the MUWC pump at 5:30

on March 14. From then, they injected water intermittently to adjust the water level of the reactor. At 9:27 on March 14, they also supplied water to the SFP. From March 16 to 17, part of the SFP water was drained to the S/C and supplied by the MUWC pump, and an increase in the water temperature of the SFP was controlled.

On March 17, in order to install a temporary submersible pump the workers removed debris scattered by the tsunami and such like. Then, they prepared a power supply on March 18, and installed a temporary seawater pump for the RHR in the water intake trench, and activated it on March 19. As the high voltage power panel in the basement of T/B could not be used due to flooding, power was supplied to the RHR pump by directly laying a temporary cable from the power panel of Unit 6. Then, the RHR pump was started around 5:00 on March 19, and the SFP began to be cooled.

Then, the Station decided to alternately cool the SFP and reactor by switching the system configuration. The workers started cooling the reactor at 12:25 on March 20. At 14:30 on March 20, the reactor achieved a cold shutdown.

### Table 2.6-1 Main Chronology (Unit 5)

March 11, 2011 (Friday)

- 14:46 Great East Japan Earthquake occurred.
- 14:47 The emergency DGs of Unit 5 were automatically activated.
- 15:27 The first tsunami arrived.
- 15:35 The second tsunami arrived.
- 15:40 Total Blackout
- 15:42 The Station determines that for Unit 1\*, Unit 2\*, Unit 3\*, Unit 4\*, and Unit 5\*, a specific event (Total Blackout) based on Article 10 of the Special Law on Emergency Preparedness for Nuclear Disaster occurred, and the authorities were notified accordingly.
  - \* On April 24, 2011, a correction was made to the effect that the specific event had occurred only at Unit 1, Unit 2, and Unit 3.

March 12, 2011 (Saturday)

- 0:09 TEPCO departed for the site at Unit 5 and Unit 6 to inspect the power supply system in the station.
- About 1:40 The SRV was automatically opened. (From then, pressure of the reactor was maintained at approximately 8 MPa through repeated opening and closing.)
- 6:06 The pressure of the RPV was reduced by opening the valve on the top of the RPV.
- 8:13 Electric power interchange to Unit 5 (part of the DC power supply) was enabled by the provided cable from the DG of Unit 6.
- 14:42 With the power supply from the DG, the air conditioning system on the side of Unit 6 of the MCR emergency ventilation and air conditioning system of Unit 5 and 6 was manually started and cleaning of air in the MCR of Unit 5 and 6 was started.

March 13, 2011 (Sunday)

- 18:29 Supply of power by the temporary cable from the DG of Unit 6 to the MUWC started.
- 20:54 The MUWC pump was manually started.
- 20:54 The SGTS was manually started.

March 14, 2011 (Monday)

- 5:00 The SRV was opened and pressure of the RPV was reduced. (From then, the opening operation was conducted intermittently.)
- 5:30 Water injection into the reactor by the MUWC was started. (From then, water was injected intermittently.)
- 9:27 Supply of water to the Spent Fuel Pool was started. (From then, the supply was conducted intermittently.)

March 16, 2011 (Wednesday)

- 22:16 Change of water in the Spent Fuel Pool was started.

March 17, 2011 (Thursday)

- 5:43 Change of water in the Spent Fuel Pool completed.

March 18, 2011 (Friday)

13:30 Workers completed making holes (at three locations) in the roof of the reactor building.

March 19, 2011 (Saturday)

1:55 The RHR temporary seawater pump was activated by the temporary power supply from the power supply vehicle.

4:22 The second DG of Unit 6 was started

About 5:00 The RHR was manually started. (Cooling of the Spent Fuel Pool was started in emergency load mode.)

March 20, 2011 (Sunday)

10:49 The RHR was manually stopped. (Emergency thermal load mode.)

12:25 The RHR was manually started. (Cooling of the reactor was started in stop cooling mode.)

14:30 The water temperature of the reactor fell below 100°C and the reactor achieved a cold shutdown.

## 2.7 Course of accident at Unit 6

Unit 6 had been suspended since August 14, 2010 due to a periodic inspection. When the earthquake occurred, the reactor was loaded with fuel, and the top lid of the RPV was tightened by bolts. The reactor was in a cold shutdown condition and the control rods were fully inserted. The duty person before the earthquake occurred confirmed that the water level of the SFP was full (around the overflow level), and that water temperature of the pool was 25°C.

At 14:47 on March 11, the collapse of the steel towers of Yoronomori transmission line due to the earthquake caused a loss of external power supply, which automatically activated three emergency DGs. As a result of the loss of external power supply, operation of the RHR and FPC halted. As the reactor had been in a cold shutdown condition before the earthquake, the water temperature of the SFP was sufficiently low and time was not pressing. Thus, the RHR and FPC were put into a standby state.

Then, at 15:36 on March 11, affected by the massive tsunami, two emergency DGs (6A, HPCSDG) lost functionality due to the flooding of the seawater pumps or power panel and such like. However, one emergency DG (6B) continued to operate as it was of an air-cooled type and the power panel was still usable. This enabled a supply of power necessary to allow the Station to supply water into the reactor. The RHR, Low Pressure Core Spray System, and High Pressure Core Spray System (hereafter called "HPCS") became inoperable due to a loss of power or submerged seawater pumps.

The pressure in the reactor moderately increased due to the decay heat after the earthquake occurred; however, the rate of increase was more modest than that of Unit 5 because a longer period of time had elapsed after the halt.

At 13:01 on March 13, the MUWC pump was started, and at 13:20, injection of water into the reactor from the CST was started. After March 14, the SRV was used to reduce pressure as appropriate, and the reactor pressure and water level were controlled.

The workers tried to cool the SFP, but as the seawater pumps were unusable due to the massive tsunami, they stirred the water in the pool several times after March 16 with the FPC pump that was still operable with the one remaining emergency DG.

From March 17, in order to install a temporary submersible pump, the workers conducted debris removal work, prepared a power supply, and did other tasks. They installed a temporary seawater pump for the RHR in the water intake trench and started it on March 19. Then, at 22:14 on March 19, the RHR pump was started and cooling of the SFP was started.

As the soundness of the DG seawater pump (6A) flooded by the tsunami was confirmed on March 18, the same seawater pump was started at 19:07 on March 18, and the emergency DG (6A) was started at 4:22 on March 19.

Then, the Station decided to alternately cool the reactor and SFP by switching the system configuration, and the reactor started to be cooled at 18:46 on March 20. The reactor achieved a cold shutdown at 19:27 on March 20.

### Table 2.7-1 Main Chronology (Unit 6)

March 11, 2011 (Friday)

- 14:46 Great East Japan Earthquake occurred.
- 14:47 The three emergency DGs of Unit 6 were automatically activated.
- 15:27 The first tsunami arrived.
- 15:35 The second tsunami arrived.
- 15:36 The two DGs of Unit 6 tripped.

March 12, 2011 (Saturday)

- 8:13 Electric power interchange from the emergency DGs of Unit 5 and Unit 6 was enabled.

March 13, 2011 (Sunday)

- 13:20 With the power supply from the emergency DG of Unit 6, water injection by the condensate transfer pump was started. (Then, water was injected intermittently.)

March 14, 2011 (Monday)

- 14:13 Supply of water into the Spent Fuel Pool was started. (Then, water was supplied intermittently.)

March 16, 2011 (Wednesday)

- 13:10 The FPC was manually started. (Cycle operation without heat removal capability.)

March 18, 2011 (Friday)

- 17:00 Workers completed making holes (at three locations) on the roof of the reactor building.
- 19:07 The DG seawater pump was started.

March 19, 2011 (Saturday)

- 4:22 The second DG was started.
- 21:26 With the temporary power supply of the power supply vehicle, the RHR temporary seawater pump was started.
- 22:14 The RHR was manually started. (Cooling of the Spent Fuel Pool was started in emergency load mode.)

March 20, 2011 (Sunday)

- 16:26 The RHR was manually stopped. (Emergency thermal load mode)
- 18:48 The RHR was manually started. (Cooling of the reactor was started in stopped cooling mode.)
- 19:27 The water temperature of the reactor fell below 100°C and the reactor achieved a cold shutdown.

## 2.8 Status of Dose Rate Around Power Station

As the MP halted, the dose rate around the power station could not be measured with MP. However, measurements were carried out with the monitoring car that was deployed as a replacement of MP in the vicinity of the main gate of the station. Figure 2.8-1 shows the measurement results.

In Unit 1, around 14:00 on March 12, the temporary air compressor for operating the major valve of the S/C vent valve (AO valve) was installed, and a drop in the D/W pressure was confirmed at 14:30. Since then, the workers performed vent operations, including those for Unit 2 and Unit 3, were performed several times.

For the dose rate, no big change in the background level before and after these vent operations was observed. However, from 4:00 to 7:00 on March 12, the dose rate increased. In addition, around 6:14 on March 15, the sound of an explosion was confirmed, and the background level of the dose rate increased before and after it.

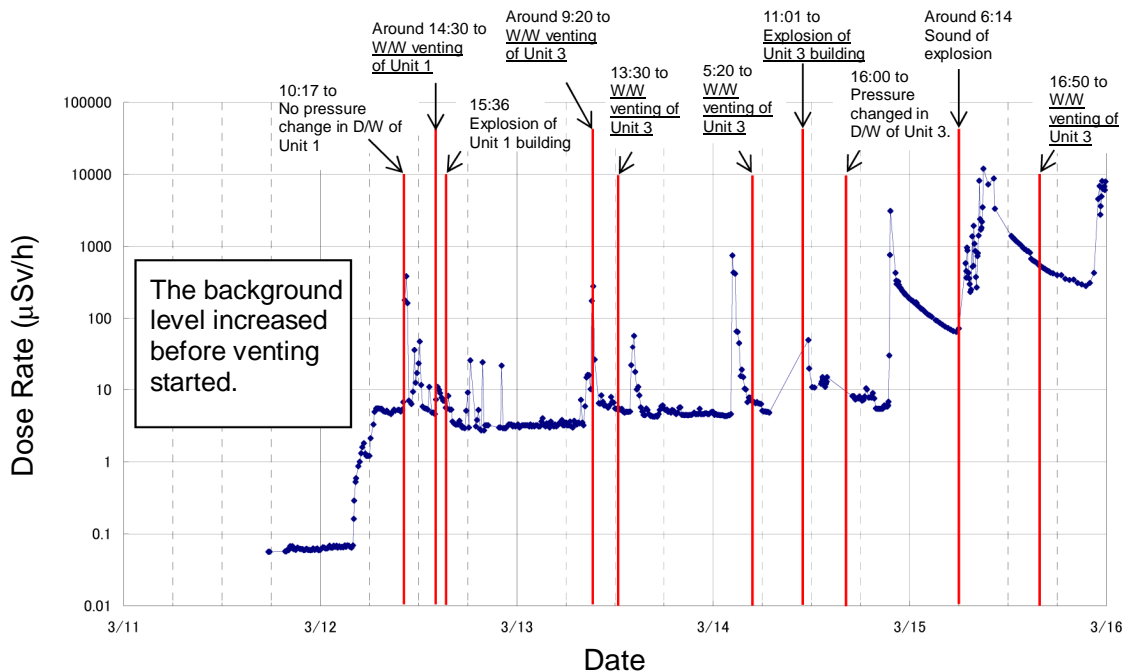

**Fig. 2.8-1 Fukushima Daiichi Nuclear Power Station Fukushima Daiichi Nuclear Power Station Nuclear Power Plant Dose Rate in the Vicinity of Main Gate**

## 2.9 Evaluation of Core core Conditions conditions of Unit 1 to Unit 3 at the Time time of Accident accident

TEPCO implemented the event progress analysis on the core conditions of Unit 1 to Unit 3 when the accident occurred, by using the severe accident analysis code. The analysis result is outlined in the following.

The analysis result indicates that in the shortest case, the reactor core damage started in Unit 1, 4 hours after the earthquake occurred. In comparison of with the shortest cases, the result also shows that the core damage started in Unit 2 and in Unit 3, respectively, 77 hours and 42 hours after occurrence of the earthquake. The time to the core damage in Unit 2 and Unit 3 was extended longer by the period of time during which the respective RCIC or HPCI worked.

### 2.9.1 Evaluation of Core core Conditions conditions of Unit 1 at tthe Time of Accidentaccident

- In the analysis, tThe analysis was implemented, assuming the condition of gaseous leak from the containment vessel (about 18 hours after occurrence of the earthquake) and operating conditions of the IC (it became inoperable after the station blackout). As a result, the main development is as shown below:
  - Time when exposure of the core started:  
About three hours after occurrence of the earthquake
  - Time when the core damage started:  
About four hours after occurrence of the earthquake
  - Time when the RVP was broken:  
About 15 hours after occurrence of the earthquake
- After the assumed timing of the IC stop, the water level of the reactor reached the Top of Active Fuel in about two hours, then and this leading to the rector damage.
- Although the reactor pressure increases after the assumed timing of the IC stop, it remains around 8 MPa (abs) because of the Safety Relief Valve. After the reactor core is damaged, the melted pellets move to the lower plenum. Then, about 15 hours after the earthquake, the RPV breaks and the reactor pressure decreases rapidly.
- 
- The pressure of the containment vessel temporarily increases because of the steam released from the RPV and hydrogen gas formed by the reaction of water and metal in the reactor. However, after that, the pressure shows a decreasing trend because of the leakage from the containment vessel assumed in the analysis, and then it decreases rapidly by the vent operation on March 12.
- The PCV temperature is over 300°C about 18 hours after occurrence of the earthquake, and well exceeds the designed temperature of the containment vessel (138°C).
- Hydrogen is generated almost simultaneously with the core damage, and there is the possibility that the explosion of March 12 was caused by the hydrogen generated then.

- Regarding radioactive substances to be released as a result of core damage, almost all noble gases are released to the atmosphere by the vent operation. According to the analysis result, approximately 1% of cesium iodide and less than about 1% of other nuclides are released.

### 2.9.2 Evaluation of Core Condition of Unit 2 at the Time of Accident

- In the analysis, the analysis was implemented, assuming the condition of gas phase leakage from the containment vessel (about 21 hours after the earthquake) and the following two cases of the amount of water injected by the fire pumps.

As a result, the main development is as shown below:

(Case1) It is assumed that the workers injected an amount of water that allowed the reactor water level to be almost comparable with the measured value was injected.

(Case 2) It is assumed that the workers injected an amount of water that did not allow the reactor water level to be maintained in the fuel range was injected.

Time when exposure of the core started:

Approx. 75 hours after occurrence of the earthquake

Time when the core damage started:

Approx. 77 hours after occurrence of the earthquake

Time when the RVP was broken:

About 109 hours after occurrence of the earthquake (in the case of Case 2)

- The reactor water level gradually goes down after the RCIC stops, and the reactor core starts to be exposed. After the SRV is opened, the reactor core damage starts.
- The reactor pressure is kept high around the SRV operating pressure until the RCIC stops. As a result of opening of the SRV following the RCIC stop, the reactor pressure decreases rapidly, then going goes down to near atmospheric pressure.
- The pressure in the containment vessel gradually increases as the water temperature of the suppression pool rises. The opening of the SRV following the RCIC stop results in a temporary pressure buildup, and then the pressure shows a decreasing trend because of the leakage from the suppression chamber assumed in the analysis. (Note that it is currently unknown whether the assumed leak from the containment vessel actually occurred or whether that was only a problem of instrumentation.)
- A large amount of hydrogen results from the reaction of metal and water in a period when the reactor core is exposed and the temperature of fuel cladding tube starts to rise.
- Of the radioactive substances to be released due to the core damage, noble gases are released from the pressure vessel to the Suppression Chamber. With the assumed leak from the Suppression Chamber, almost total volume of the noble gases is to be released into the environment. For cesium iodide, the analysis result shows that the release rate is 1% or lower, and most of it exists in the Suppression Chamber. (It should be noted,

however, that behavior of radioactive substances greatly depends on the effect of the analysis conditions or uncertainty in models.)

### 2.9.3 Evaluation of Core core Conditions conditions of Unit 3 at the Time of Accident

- In the analysis, (The analysis was implemented, assuming the following two cases of the amount of water injected by the fire pumps. As a result, the main development is as shown below:

(Case1) It is assumed that the workers injected an amount of water that allowed the reactor water level to be almost comparable with the measured value was injected.

(Case 2) It is assumed that the workers injected an amount of water that did not allow the reactor water level to be maintained in the fuel range was injected.

Time when exposure of the core started:

Approx. 40 hours after occurrence of the earthquake

Time when the core damage started:

Approx. 42 hours after occurrence of the earthquake

Time when the RVP was broken:

About 66 hours after occurrence of the earthquake (in the case of Case 2)

- The reactor water level gradually goes down after the HPCI stops, and the reactor core starts to be exposed. After the SRV is opened, the reactor core damage starts.
- The reactor pressure is kept high around the SRV operating pressure until the HPCI stops. As a result of opening of the SRV following the HPCI stop, the reactor pressure decreases rapidly, then going goes down to near atmospheric pressure.
- The pressure in the containment vessel gradually increases as the water temperature of the suppression pool rises. Although the pressure temporarily goes high due to the opening of the SRV following the HPCI stop, it decreases by venting from the Suppression Chamber. Then, the pressure repeats repeatedly increasing/es and decreasingdecreases, depending on the venting operations.
- A large amount of hydrogen results from the reaction of metal and water in a period when the reactor core is exposed and the temperature of fuel cladding tube starts to rise. The possibility is pointed out that the explosion of March 14 was caused by the hydrogen generated in this period.
- Of the radioactive substances to be released due to the core damage, noble gases are released from the pressure vessel to the Suppression Chamber, and almost total volume of all the noble gases is are to be released into the environment by venting. For cesium iodide, the analysis result shows that the release rate is about 0.5%, and most of it exists in the Suppression Chamber. (It should be noted, however, that behavior of radioactive substances greatly depends on the effect of the analysis conditions or uncertainty in models.)

## Source Material

(1) Report of Japanese Government to the IAEA Ministerial Conference on Nuclear Safety, 2011 June

- [http://www.kantei.go.jp/jp/topics/2011/pdf/houkokusyo\\_full.pdf](http://www.kantei.go.jp/jp/topics/2011/pdf/houkokusyo_full.pdf)
- [http://www.kantei.go.jp/jp/topics/2011/pdf/app\\_full.pdf](http://www.kantei.go.jp/jp/topics/2011/pdf/app_full.pdf)

## Chapter 3 Analysis of Causes for Accident Events and Extraction of Problems

Problems of the accident are that cores were damaged and that radioactivity was discharged to the environment. We analyzed the accident to identify the causes for the accident with an event tree and extracted problems to clarify what made the accident expand and diminish.

In addition, in order to pick up problems exhaustively, we made analyses with the focus on functional aspects of “to shut off”, “to cool down” and “to confine”.

### 3.1 Flow of Progress of Accident Events

The event tree of progress of events in each reactor is shown in Fig. 3.1-1. The event tree was prepared in a configuration that allows to tell how power functions (DC power, external power and emergency DG) were lost by the initial event (earthquake) and the following tsunami, short-term core cooling operations (systems that don't depend on AC power such as IC, RCIC, and others) and transferring operations to cool shutdown (reactor depressurization, water injection to reactor, container ventilation, and others) or success or failure of mitigation measures (cooling damaged core and container and reactor building control). Also, it was prepared so that it clearly shows actions in the case where the power is restored and functions of facilities can be restored (existing and established severe accident management) and actions in the case like this time where power restoration was not possible and functions of facilities are difficult to restore.

For Reactor No. 1, in addition to loss of external power due to the earthquake, loss of emergency DG due to tsunami made all AC power unavailable. Besides, DC power was lost too. It was verified that the IC worked until the tsunami attacked the power plant. It is assumed that the core was damaged after arrival of the tsunami. Then, it is assumed that hydrogen generated in the core leaked from the container to the reactor building causing hydrogen explosion and resulted in discharge of radioactivity to the environment.

For Reactor No. 2, because of loss of external power due to the earthquake and loss of emergency DG due to tsunami, all AC power was lost. Besides, DC power was lost too. Cooling the core was secured by the RCIC which was started to work prior to loss of DC power and worked for less than three days until around 13:30 of 14th. But, it is guessed, since it took time to implement alternate water injection after stop working of the RCIC and injected water amount was too little, the core was damaged.

For Reactor No. 3, because of loss of external power due to the earthquake and loss of emergency DG due to tsunami, all AC power was lost. Besides, DC power was lost too. But the RCIC and the HPCI worked and secured core cooling for one-and-a-half-day until DC power was ran out at around 2:40 of 13th. But, it is assumed, since it took time to implement alternate water injection after stop of the RCIC and the HPCI and injected water amount was too little, the core was damaged. After that, it is guessed, hydrogen generated in the core leaked to the PCV and the R/B causing hydrogen explosion and resulted in discharge of radioactivity to the environment.

For Reactor No. 4 (under suspension due to periodical inspection), because of loss of external power due to the earthquake and loss of emergency DG due to tsunami, all AC power was lost. Besides, DC power was lost too. There were fuels of relatively high decay heat taken out from the core shortly before that time in the SFP but water in the pool could not be cooled with the FPC due to loss of power. And, 5th floor of the Reactor No. 4 building was damaged by hydrogen explosion. Afterward, water injection to the SFP was executed with a concrete pump vehicle.

In the Reactor No. 5 (under suspension due to periodical inspection), fuels were loaded in the reactor and a test for pressure resistance and leakage of the RPV with the control rods being fully inserted was performed at the time of the earthquake. Although all AC power was lost due to the earthquake and the tsunami, AC power was secured by the power provided from the Reactor No. 6. The seawater pumps in the RHR line were damaged by the tsunami, but the makeshift seawater pumps were used for the RHR and the spent fuel pool and the reactor well were cooled by the RHR line. With this, the reactor got in a state of cold shutdown.

The Reactor No. 6 (under suspension for periodical inspection) was in a state of cold shutdown with all fuels being loaded and the upper lid of the RPV being shut. Since external power was lost due to the earthquake three emergency DGs started to work automatically but two units of them became inoperable because functions of the seawater pump and the power panel were lost due to attack of the tsunami. As AC power was secured with remaining one unit (air-cooling type), power supply for the reactor, cooling the SFP and for the Reactor No. 5 was performed. The seawater pumps in the RHR line were damaged by the tsunami, but the makeshift seawater pumps were used for the RHR and the reactor well was cooled by the RHR line. With this, the reactor returned to the state of cold shutdown.

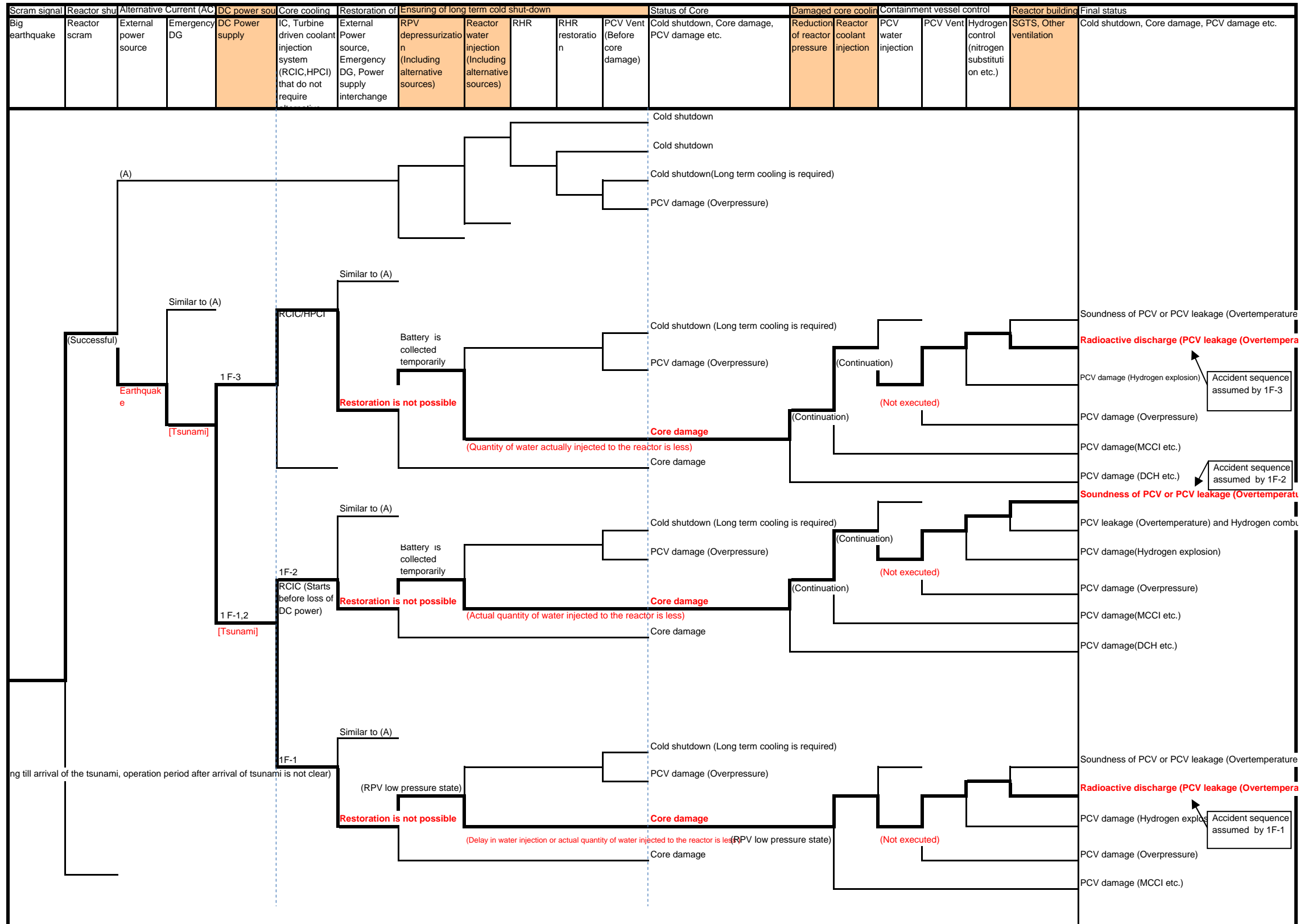

Diagram 3.1-1 Event tree of event progress in Fukushima No.1 nuclear power plant, Unit no.1- Unit no. 3

## **3.2 Extraction of subject from accident event progress**

### **3.2.1 Cause analysis from accident event progress (event tree)**

3.1 The following three items have been extracted as the main factors of core damage and emission of radioactivity to the environment from the progress flow of accident event (event tree).

- 1) Inability of all AC power supply
- 2) Inability of heat removing from nuclear reactor
- 3) Hydrogen leakage to building and hydrogen explosion

Cause analysis of the above-mentioned three factors was executed to extract the subject.

Moreover a common factor which obstructed work accomplishment was dug up through the cause analysis. These factors were analyzed to extract the subject.

#### **(1) Inability of all AC power supply**

Figure 3.2.1-1 shows the result of analysis of the cause that AC power could not to be supplied.

Before strike of tidal waves, the AC power was supplied by the external source before the earthquake occurred and it was supplied by the emergency DG after the earthquake occurred.

The cause where AC power could not be supplied from the view of the equipment and operation includes inability of power supply from the external source, inability of power supply by emergency DG, inability of joint use of power supply and inability of power supply restoration at early stage.

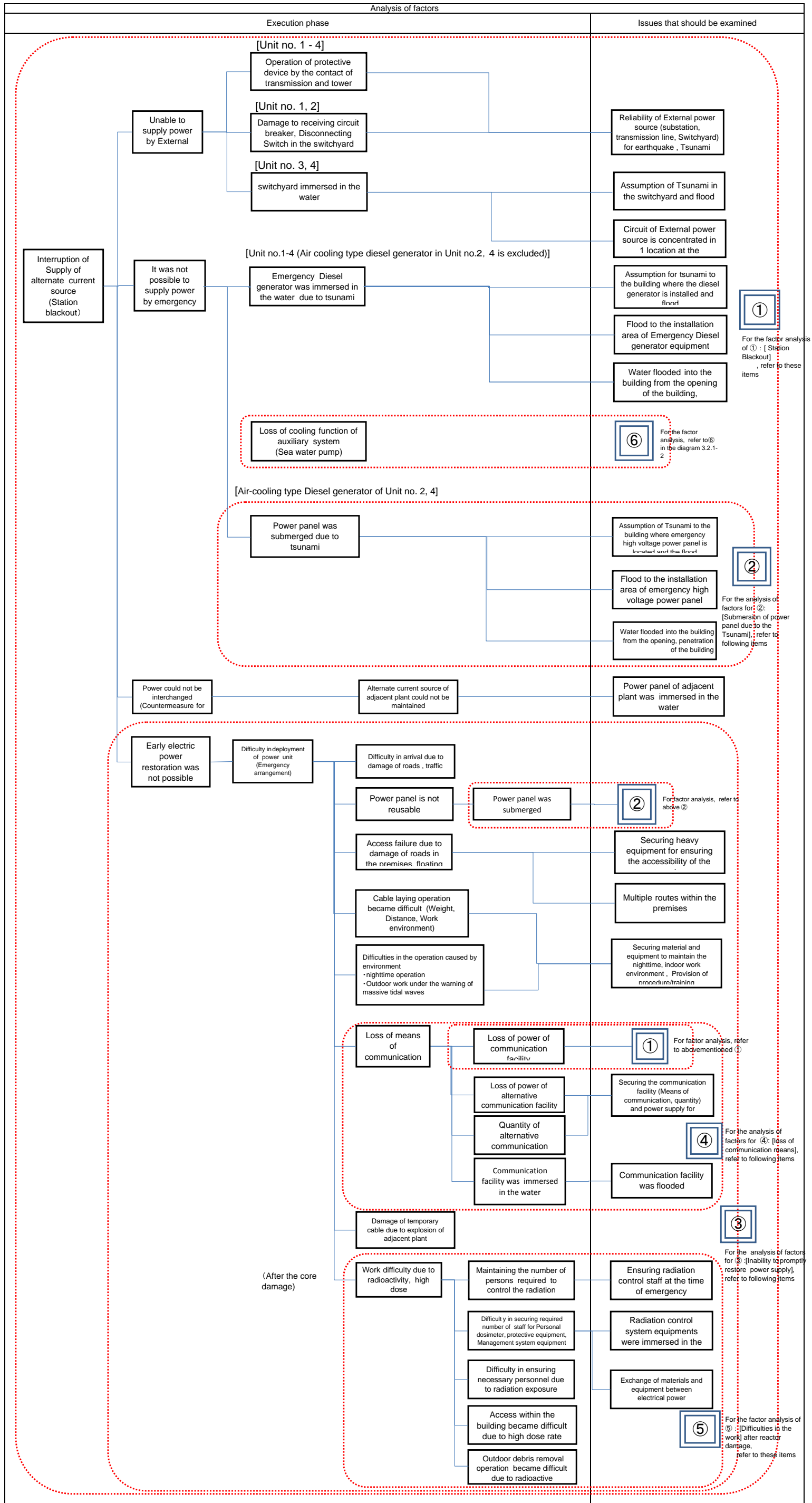

Diagram 3.2.1-1 Analysis of causes for interruption of supply of alternate current power

**a. Inability of power supply from the external source**

Inability of power supply from the external source

The power supply from the outside was able to be received from the new Fukushima substation. After the earthquake, however, the power supply lost the function with the damage of the substation equipment due to the earthquake, with the damage of receiving breaker and disconnecting switch in the switchyard in the power plant due to the earthquake, and with the movement of protection instrument caused by the contact of power line and steel tower etc.

Note that traces where tidal waves reached were confirmed at the switchyard of Units 3 and 4.

From these points the following is listed as the examining subject to maintain the power supply by the external source.

- Reliability of external source (substation, power line and switchyard) to earthquake and tidal waves
- Flooding of switchyard by tidal waves
- Provision to concentration of external source lines to one place in substation (multiplexing of line)

**b. Inability of power supply by emergency diesel generator**

The power had been supplied by emergency DG after the earthquake. After the strike of tidal waves, functions of seawater pumps were lost except Unit 6 and functions of DG were lost because of flooding into the building. Although air-cooled emergency DG of Units 2 and 4 did not encounter flooding because of tidal waves, they lost power supply functions because the high-voltage power supply panel was flooded.

From these points the following is listed as the examining subject to maintain the power supply by emergency DG.

- Flooding to installation area of emergency power generating machine (DG and power supply panel)
- Flooding into building from opening and through part of building
- Flooding on cooling seawater system pump for emergency DG

Note that AC power could be supplied for Units 5 and 6 by air-cooled emergency DG of Unit 6.

**c. Inability of joint use of power supply**

Joint use of power supply from adjacent unit prepared for severe accident was not performed for Units 1 to 4 since the power was lost on all these units.

Joint use of power supply could be performed since the AC power had been supplied for Units 5 and 6 from emergency DG of Unit 6.

**d. Inability of power supply restoration at early stage (excluding Units 5 and 6 for which AC power was secured)**

Since the AC power was lost, an attempt was made to restore the power supply by arranging power source cars for emergency for prompt procuring outside the power plant. As a result, however, the power supply could not be restored before the core became damaged.

Work of early power supply restoration was frequently interrupted by the influence of aftershock and official announcement of tidal wave warning. Moreover night work or work under official announcement of tidal waves warning caused to lower its efficiency.

In work in the building (cable laying work), interior lighting was lost along with the loss of the power supply. Work was done by using the limited amount of flashlight etc. In addition the communication equipment (paging and security telephone) excluding some apparatuses becomes impossible to use because of flooding or losing the power supply. It became impossible to use the cellular phone and PHS gradually by the consumption of the battery. Communication means between work sites, or with MCR or emergency station were broken off and work became difficult.

From these points the following is listed as the examining subject to restore the power supply at early stage  
Flooding on power supply panel

Moreover the following is listed as the subject to improve the effectiveness of recovery efforts.

- Securing the machine and material to secure working environment in nighttime or room
- Securing the heavy equipment to secure accessibility of road
- Multiple route in the plant
- Communication equipment (communication means and amount) and securing the power supply for communication including batteries
- Flooding on communication equipment

Furthermore, "Maintenance of procedure and training" is also extracted as a subject necessary to improve the effectiveness of work though it is not limited to the power supply restoration.

After the hydrogen explosion after reactor core damage had occurred, difficult situation to work was caused.

Workers got injured by the hydrogen explosion of the reactor building. In Unit 1, a loss such as the damage of cable installed for emergency to execute alternative water filling using the boric acid water filling pump was encountered. Moreover labor and time were spent on work to remove wreckage polluted with radioactivity, and time was required for outdoor work.

In addition a lot of personal dosimeters and the radiation control system are flooded by tidal waves. Hence personal dosimeters became insufficient and the number that all workers wore could not be secured.

From these points the following is listed as the examining subject to be extracted.

- Joint use of the machine and material between electric powers
- Securing of radiation control workers for emergency
- Flooding on radiation control system

**(2) Inability of heat removing from nuclear reactor (excluding Units 4, 5 and 6 being stopped)**

Figure 3.2.1-2 shows the result of analysis of the cause that heat could not be removed from the nuclear reactor.

IC (Unit 1), HPCI (Units 1 - 3) and RCIC (Units 2 and 3) were built as the heat removing equipment and as the high pressure system equipment to decompress the nuclear reactor.

In addition in Unit 1, SRV (relief valve function/automatic decompression function) to decompress the nuclear reactor and CS that conducts injection to the reactor core at low pressure were installed. In Units 2 and 3, RHR (low-pressure injection mode) was installed in addition to SRV and CS. Moreover in Units 1 - 3, the containment vessel vent unit to prevent overpressure of containment vessel and the severe accident measure equipment were provided.

The cause of heat removing impossible from nuclear reactor from the view of the equipment and operation includes inability of decompression by SRV, inability of heat removing by CS and RHR, inability of heat removing by severe accident measure equipment (alternative water filling), and difficulty in containment vessel vent.

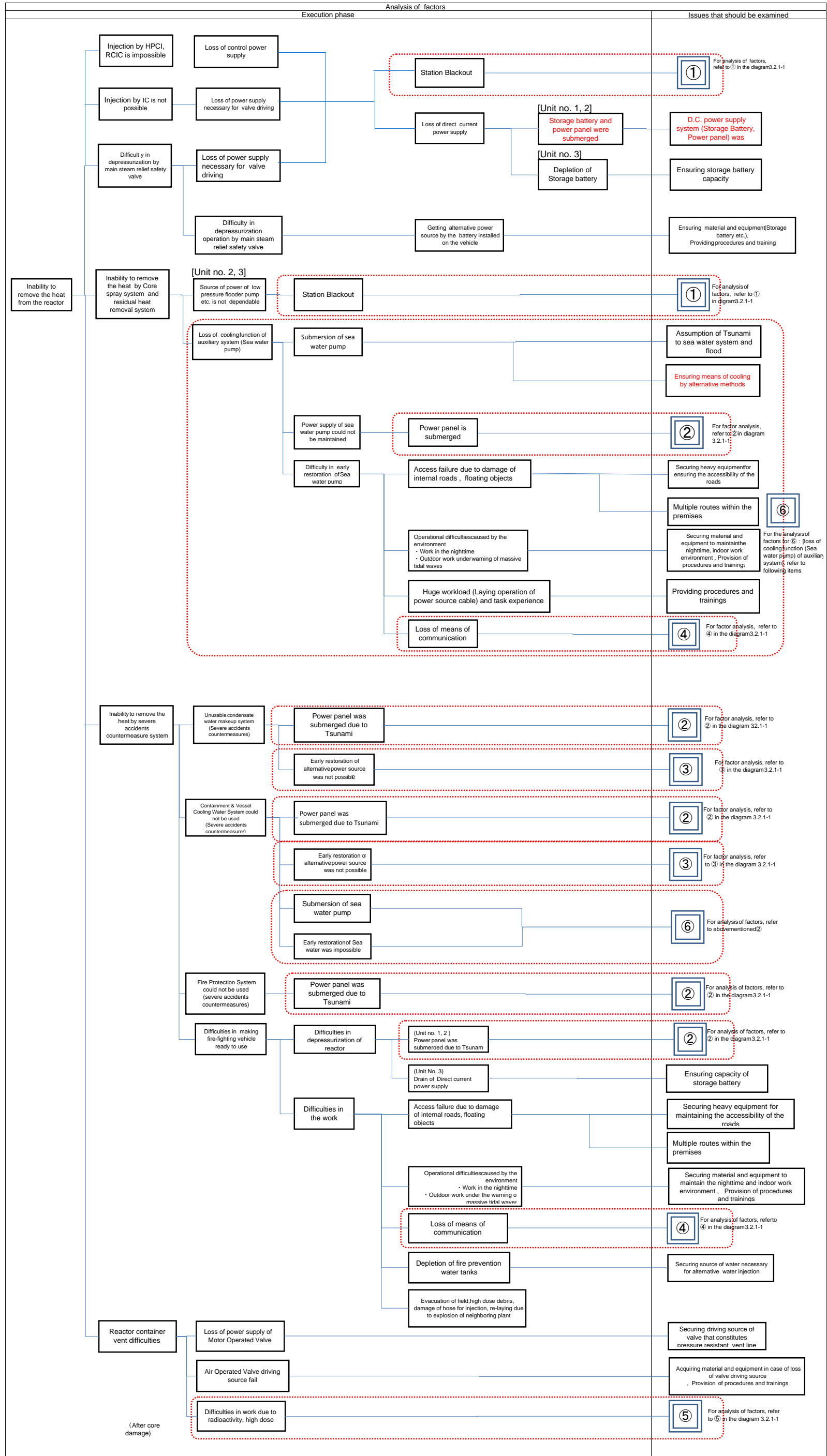

Diagram 3.2.1-2 Analysis of causes of inability to remove heat from the reactor

**a. Inability of cooling by emergency condenser, high pressure injection system and reactor core isolation cooling system**

IC in the Unit 1 was manually shut down before the tsunami reached the power station to protect the cooling rate. However the DC power was lost under the impact of tsunami with the valve closed, operation became impossible. Thereafter, an operation to open the valve was conducted and generation of steam was confirmed. Nevertheless, the extent of the operation performance is unknown. Actually, we suppose that only limited level of cooling could be achieved.

The HPCIs in the Unit 1 and Unit 2 were in the stand-by mode, because they did not reach the start-up condition before arrival of the tsunami.

However, because their DC power was lost under the impact of the tsunami, their functions were lost. The HPCI in the Unit 3 started up automatically due to the drop of reactor coolant level. Then, the system must have shut down due to the drop of reactor pressure, which led to an operation inability due to deficit of DC power.

The RCIC in the Unit 3 was started up manually after the reactor scram. The system was started up and shut down for adjustment of reactor water level adjustment. While the operation was continued even after the arrival of tsunami, the operation must have shut down due to the exhaustion of battery power.

Based on above, following items are listed as agenda for review to ensure maintenance of functions of IC, HPCI and RCIC.

- Submergence of DC power systems (Battery cell, power unit)
- Security of battery capacity

**b. Inability of depressurization by main steam safety relief valve**

In the Unit 1 and Unit 2, the DC power necessary to drive SRVs was lost due to submergence under the impact of the tsunami. With regard do the Unit 3, its function was lost with other components opeated by DC power on March 13 due to exhaustion of DC power, while the DC power was not affected by submergence caused by the tsunami.

To achieve alternative coolant injection, it was necessary to depressuize the reactor by operating the SRVs. Therefore, it was necessary to open an electromagnetic valve for supplying nitrogen as a source to drive the SRVs. In the Unit 3, an operation to open electromagnetic valves was tried by using on-board battery of fire engines when they came to the site for alternative water injection. Because the battery cells store in the station were used for the recovery of instrumentation in the Unit 1 and Unit 2, batteries were collected from the vehicles of employees who were working in the on-site disaster countermeasure headquarters and connected to the instrumentation panels. Finally, after 6 hours from the loss of high pressure injection system function, the SRV were opened and rapid depressurization of the reactor could be achieved.

Based on above, following items are listed as agenda for review to maintain depressurization function by SRVs.

- Inability of supplying DC power (See 3.2.1(1))
- Submergence of AC power systems (Battery cell, power unit)
- Security of battery capacity

- Security of materials and equipment to ensure SRV operation in the event of loss of DC power and implementation of the procedure and the training thereof

**c. Inability to remove residual heat by core spray system (Units 1~3) and residual heat removal system (Units 2/3)**

The cause of inability to remove residual heat by using CS and RHR (low pressure injection mode) is attributable to an inability to supply AC power and the function loss of sea water pumps for cooling related auxiliary components. The cause of inability to supply AC power was already explained in 3.2.1(1). The cause of cooling function loss in sea water pumps was the submergence caused by tsunami that exceeded the estimated highest level (O.P.5.7m). All of the sea water pumps lost their functions simultaneously.

With regard to the recovery of sea water pumps, considerable time was spent due to multiple factors as below: -Access to sea pump installation area was extremely restricted due to the damage caused by the Earthquake and the tsunami, while spare sea water pumps were maintained; -Works were interrupted repeatedly due to aftershock; -Work efficiency was poor because of the issue of great tsunami alarm at night etc. Besides the sea water pumps, the electric units necessary for the function of component cooling system were submerged. Therefore, early restoration of this system was extremely difficult.

Based on above, following items are listed as agenda for review to maintain residual heat removal function by CS and RHR.

- Estimation of tsunami and submergence of sea water systems
- Security of cooling method by using alternative approaches

Inability to remove residual heat by systems for severe accident countermeasure

As systems for severe accident countermeasure for the loss of injection function, MUWC, CCS and FP had been prepared.

However, almost none of these could be used for most of the systems due to loss of entire AC power and the function loss of auxiliary component cooling system.

While it was stipulated to use FPs as an alternative injection system based on severe accident countermeasures, function of the motor operated fire extinguishing pumps was lost due to power loss. While the pumps driven by diesel motor could be operated temporarily, they were shut down later due to malfunction. It seems that these pumps failed to achieve start-up operation in the Unit 2, the cause of this failure is unknown, making it difficult to judge whether or not this event is attributable to the component failure. In the Unit 3, these pumps operated temporarily and shut down later. Details of this event are unknown.

While water injection to the reactor was tried by using fire engines that were maintained as a part of earthquake preparedness after the earthquake that attacked Kashiwazaki Kariwa Nuclear Power Station, considerable time was spent before actually injecting water to the reactor due to multiple factors as below: -Access to the outdoor area was extremely difficult; -Works were interrupted repeatedly due to aftershock; -Work efficiency was poor because of the issue of great tsunami alarm at night etc. As a

consequence, it was impossible to inject water before core damage. Although the fresh water injection to the reactor was started by using the fire water tank as a water source, the water source was switched to the sea water reserved in back wash valve pit in the afternoon on March 12 due to exhaustion of the fresh water.

Further, injury of operators occurred due to hydrogen explosion in the reactor building. Hoses and fire engines prepared for alternative injection were damaged by hydrogen explosion and made unavailable. Materials and equipment left behind on site caused disturbance in outdoor works later, which became a contributing factor of prolonged work period.

Based on above, following items are listed as agenda for review to secure residual heat removal function by using systems for severe accident countermeasure:

- Loss of AC power
- Loss of sea water pump function
- Security of water source necessary for alternative injection

#### **d. Containment vent work**

Purpose of the containment venting is to secure integrity of the reactor containment unit by relieving elevated containment pressure. Further, the venting may be used to discharge heat when reactor heat is accumulated inside the containment due to the loss of safety-related systems.

In the Units 1~3 of Fukushima Daiichi Nuclear Power Station, the purpose of the vent work at the initial phase was to relieve pressure.

In the Units 1~3, motor operated valves and AO valves were closed on the lines that constituted the concerned systems before conducting the containment vent.

With regard to the motor operated valves, the entire AC power was lost. On top of it, pneumatic air for actuating the AO valves was lost. These events resulted in the inability to start early venting by remote control.

In the case of the Unit 1, motor operated valves were opened manually. The AO valve that constitutes the main line (=large valve) could not be easily opened by manual operation based on its structure. Therefore, the small valve was opened, instead. However, the core damage had occurred already at that time and atmospheric dose in this area was high. Besides, the work was continued in the darkness in narrow space. These factors prevented access to the valve. The operators gave up their plan to open the valve manually and determined to use the temporary compressor for the work. As a consequence, it took a long time until the start of venting.

While venting was finally achieved on the Unit 1 and Unit 3, it took a long time to reconstruct a vent line due to the loss of power and pneumatic air. It was not clear whether or not the venting was achieved in the Unit 2, because the containment pressure failed to reach the actuation pressure of rupture disc continuously for long time after the reconstruction of the vent line.

Based on above, following items are listed as agenda for review to secure implementation of containment vent:

- Security of power to drive valves that constitute the containment vent line
- Security of materials and equipment to achieve prompt line configuration in the loss of electric power / pneumatic source to drive the valves

- Improvement of procedure and training

**(3) Hydrogen leakage to building and hydrogen explosion (excluding Units 5 / 6 where hydrogen explosion did not occur)**

Analysis results of the cause of hydrogen leakage to the building and hydrogen explosion are indicated in Figure 3.2.1-3. Hydrogen leakage to the building is estimated to be attributable to the hydrogen generated from fuel cladding due to core damage. This hydrogen seems to have leaked out to the reactor building via containment vessel. With regard to the leakage from the containment to the reactor building, leakage through the flange gasket or penetration sealing with the increase of containment pressure is suspected. With regard to the Unit 2, pressure is lost from the S/C and the containment at around 6 o'clock on March 15. Further investigation is needed to identify the leakage route from RPV and the containment upon convergence of the accident.

With regard to the Unit 4, generation of large amount of hydrogen in the fuel pool is unlikely based on the analysis of nuclide by sampling the fuel pool water in addition to the result of visual observation of the fuels in the pool using monitor cameras.

Meanwhile, the SGTS exhaust pipe in the Unit 4 merged with the exhaust pipe of the Unit 3 before the stack. Therefore, the hydrogen generated in the Unit 3 may have migrated in the Unit 4 building via the SGTS exhaust pipe, resulting in a hydrogen explosion in the Unit 4 reactor building after being accumulated there for a while. Based on the radiation measurement result, radiation dose was the highest at the exit of SGTS filter train in the Unit 4. The dose gradually decreased when the measurement point is closer to the inlet. These results suggest the appropriateness of the above-mentioned scenario. While AO valve was installed on the SGTS exhaust pipe, the valve was stuck open due to the loss of pressurized instrumentation air for normal operation as well as inability to get air supply for valve actuation from back-up system (dedicated air cylinder) in the event of containment venting due to power loss.

In every plant, prior detection of hydrogen leakage into the reactor building could not be achieved. Besides, there was no mean available for removing the hydrogen under the loss of AC power.

Based on above, following items are listed as agenda for review to prevent hydrogen leakage to the buildings and the hydrogen explosion in the event of hydrogen negation due to core damage etc.:

- Hydrogen migration among the units connected via common stack
- Migration of hydrogen from containment vent line to the reactor building
- Accumulation of hydrogen in the reactor building
- Security of materials and equipment to remove hydrogen gas from the building
- Improvement of procedures and trainings

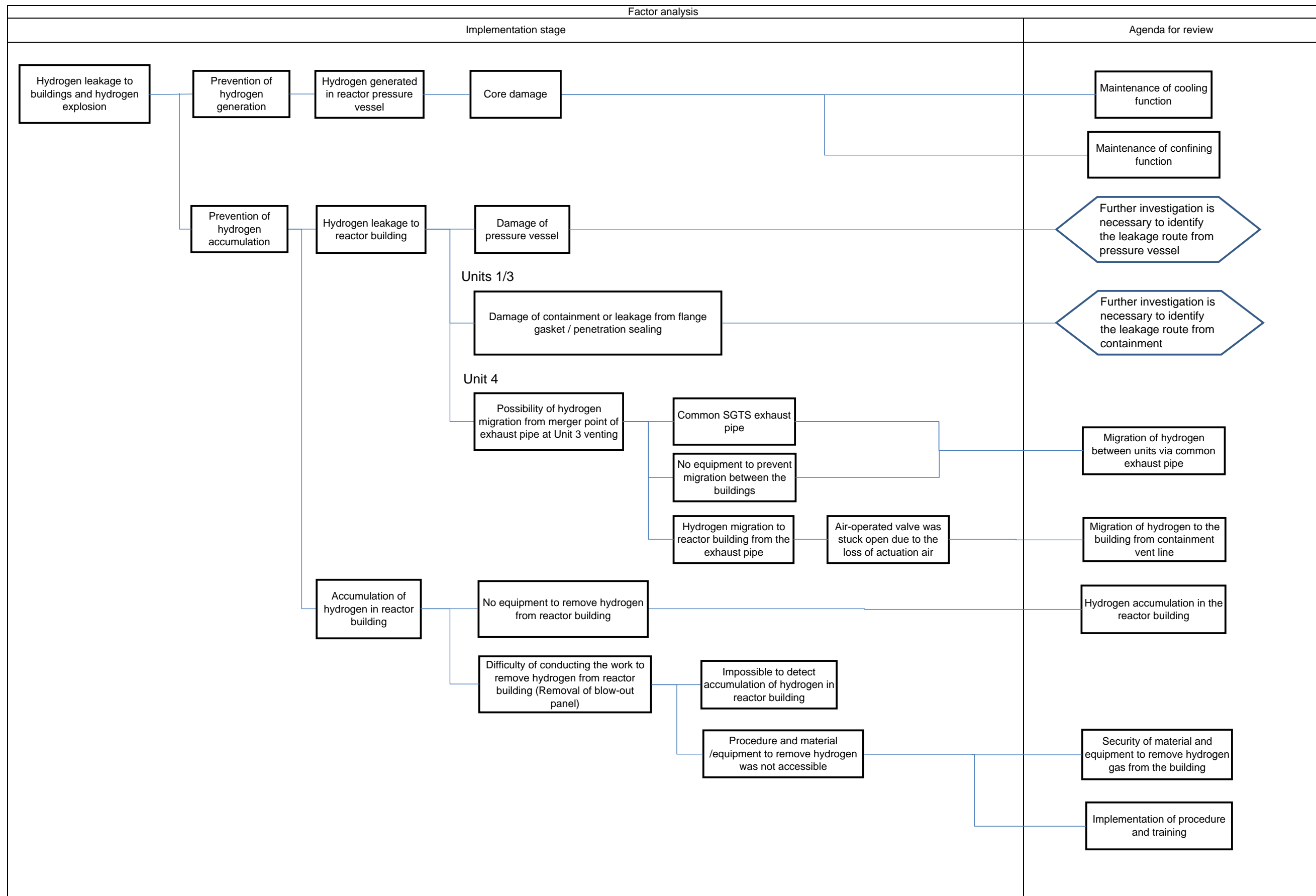

Figure 3.2.1-3: Hydrogen leakage to buildings and hydrogen explosion: Cause analysis

### **3.3 Arrangement of problems confirmed from a functional viewpoint**

Fukushima Daiichi Nuclear Power Station Reactor Unit 1 to 4, located adjacent to each other, were different in condition when the earthquake and tsunami occurred, i.e., unit 1 to 3 were producing their rated power, while unit 4 was in stop for the periodic-inspection (with all fuel discharged). In addition, unit 5 and 6 of the power station are located away from unit 1 to 4. These requirements cause differences in the progress of phenomena.

#### **3.3.1 Causal analysis of the accident in unit 1 to 3 and management of issues**

When a nuclear power station is producing its full rated power, the functions necessary for placing it in a cold shutdown state are "stopping," "cooling," and "confining," and causes of failures in the functions have been analyzed. The basic requirements (facility environment) necessary for the implementation of the operations, "stopping," "cooling," and "confining," have also been analyzed.

Common factors (permanently installed power source unavailable, alternative power supply (power supply car) unavailable, and unavailable cooling components) derived from them have furthermore been analyzed.

Tables 3.3-1 to 3.3-3 show the results of analyses on the causes of the accident, classified by functions of the **units (unit 1 to 3) producing rated power**, and the results of arrangement.

Table 3.3-1 Analysis of cause of the accident at Fukushima Daiichi Nuclear Power Plant Unit 1 and Sorting of the problems (1/2)

Safety function		Related facility, etc.		Function loss or function degradation	Cause analysis	Problem		
Stoppage	Emergency reactor shut-down function	Safety protection system, control rod and control rod drive system	O	(Normal operation when earthquake occurred)	-	-		
	Alternative reactivity control	Recirculation pump trip (AM)	-	(Not required as scram was successful)	-	-		
		Alternative control rod insertion (AM)	-	(Not required as scram was successful)	-	-		
Sub-criticality maintenance function	Borated water injection system	-	(Not required as scram was successful)	-	-			
Support systems	Power supply function	External power source	X	Loss of external power supply due to the earthquake	Receiving circuit breaker of Ookuma Line 2L in the switchyard of Unit 1/2 damaged due to the earthquake	(1) Reliability of switchyard circuit breaker		
		Emergency diesel generator	X	Function loss due to submergence	Submergence of emergency diesel generator due to the tsunami	(2) Submergence of the emergency diesel generator		
		6.9 kV high pressure power supply	X	Function loss due to submergence	Submergence of 6.9 kV high pressure power supply panels due to tsunami	(3) Submergence of 6.9 kV high pressure power supply panels		
		480V low pressure power supply	X	Function loss due to loss of 6.9 kV high pressure power supply	Submergence of 6.9 kV high pressure power supply panels due to tsunami	Same as (3)		
				Function loss due to submergence	Submergence of 480V low pressure power supply panels due to tsunami	(4) Submergence of 480V low pressure power supply panels		
	125V DC power supply	X	Function loss due to submergence	Submergence of 125V DC power supply panels due to tsunami	(5) Submergence of 125V low pressure power supply panels			
	Alternative power supply function	Power supply interchange (AM)	X	Power supply interchange unavailable from adjacent plants	Loss of station power of adjacent plant (Unit 2) due to tsunami	(6) Submergence of power supply panels of the adjacent plant		
		Power source car (emergency arrangement)	X	Difficulty in reaching	Difficulty in reaching due to damaged roads and traffic jams	(7) Procurement of alternative power supply from outside		
				Difficulty in connection work	Unable to connect due to submergence of DC power supply panels of Unit 1	Same as (3), (4)		
					Difficulty in laying cables (weight, isolation, work environment)	(8) Alternative power supply cable laying		
					Intermittent aftershocks and continuous issue of large tsunami warnings	-		
	Power supply interruption	Cables damaged and power supply car stopped automatically due to explosion in the Unit 1 Reactor Building	(9) Communication means during blackouts					
	Auxiliary cooling function	Containment vessel cooling sea water system	X	Function loss due to submergence	Submergence of containment vessel cooling sea water pump due to the tsunami	(10) Submergence of containment vessel cooling sea water pump		
				Function loss due to blackouts	Submergence of 6.9 kV high pressure power supply panels due to tsunami	Same as (3)		
		Sea water cooling system	X	Function loss due to submergence	Submergence of cooling sea water pump due to the tsunami	(11) Submergence of component cooling sea water pump		
				Function loss due to blackouts	Submergence of 6.9 kV high pressure power supply panels due to tsunami	Same as (3)		
				Function loss due to loss of DC power supply	Submergence of 125V DC power supply panels due to tsunami	Same as (5)		
		Reactor component cooling water system	X	Function loss due to loss of component cooling sea water system	Submergence of cooling sea water pump due to the tsunami	Same as (11)		
				Function loss due to blackouts	Submergence of 6.9 kV high pressure power supply panels due to tsunami	Same as (3)		
	Function loss due to loss of DC power supply	Submergence of 125V DC power supply panels due to tsunami	Same as (5)					
Cool down	Function to prevent over-pressurization of reactor coolant pressure boundary	Main steam relief safety valve (safety valve function)	-	(Controlled with emergency condenser)	-	-		
	High pressure core cooling function	High pressure core injection system	X	Function loss due to loss of DC power supply	Submergence of 125V DC power supply panels due to tsunami	Same as (5)		
		Emergency condenser (main body)	△ (Temporary operation)	Deterioration in function due to loss of DC power supply (remote operation not possible)	Submergence of 125V DC power supply panels due to tsunami	Same as (5)		
				Isolated with isolation signal transmission (Open halfway due to blackouts)	Pipe break detection circuit operational due to loss of DC power supply	(12) Verification of the design of isolation signal for loss of DC power supply		
		Emergency condenser (support system)	△ (Temporary operation)	Demineralized water supply system	X	Function loss due to blackouts	Submergence of 480V low pressure power supply panels due to tsunami	Same as (4)
				Fire protection system	Unable to use electric pump due to loss of external power supply	Receiving circuit breaker of Ookuma Line 1L damaged due to the earthquake	Same as (1)	
	Diesel driven extinguishing pump shutdown	Mechanical malfunction (presumed)	-					
	Alternative injection function (high pressure)	Borated water injection system (AM)	X	Function loss due to blackouts	Submergence of 480V low pressure power supply panels due to tsunami	Same as (4)		
				Difficulty in power supply recovery operation	[Recovery not possible] Cables damaged and power supply car stopped automatically due to explosion in the Unit 1 Reactor Building	-		
		Control rod drive water system (AM)	X	Function loss due to blackouts	Submergence of 480V low pressure power supply panels due to tsunami	Same as (4)		
				Function loss due to loss of DC power supply	Submergence of 125V DC power supply panels due to tsunami	Same as (5)		
				Function loss due to loss of component cooling sea water system	Submergence of cooling sea water pump due to the tsunami	Same as (11)		
	Reactor depressurization function	Main steam relief safety valve (relief valve function / automatic depressurization function)	X	Function loss due to loss of DC power supply	Submergence of 125V DC power supply panels due to tsunami	Same as (5)		
	Low pressure core cooling function	Core spray system	X	Injection disabled as reactor depressurization function cannot be used	Submergence of 125V DC power supply panels due to tsunami	Same as (5)		
				Function loss due to blackouts	Submergence of 6.9 kV high pressure power supply panels due to tsunami	Same as (3)		
				Function loss due to loss of DC power supply	Submergence of 125V DC power supply panels due to tsunami	Same as (5)		
				Function loss due to loss of containment vessel cooling sea water system	Submergence of containment vessel cooling sea water pump due to the tsunami	Same as (10)		
	Alternative injection function (low pressure)	Makeup water system (AM)	X	Injection disabled as reactor depressurization function cannot be used	Submergence of 125V DC power supply panels due to tsunami	Same as (5)		
				Function loss due to blackouts	Submergence of 480V low pressure power supply panels due to tsunami	Same as (4)		
		Containment vessel cooling system (AM)	X	Injection disabled as reactor depressurization function cannot be used	Submergence of 125V DC power supply panels due to tsunami	Same as (5)		
Function loss due to blackouts				Submergence of 6.9 kV high pressure power supply panels due to tsunami	Same as (3)			
Function loss due to loss of DC power supply				Submergence of 125V DC power supply panels due to tsunami	Same as (5)			
Function loss due to loss of containment vessel cooling sea water system		Submergence of containment vessel cooling sea water pump due to the tsunami	Same as (10)					
Fire protection system (AM)		X	Injection disabled as reactor depressurization function cannot be used	Submergence of 125V DC power supply panels due to tsunami	Same as (5)			
			Diesel driven extinguishing pump shutdown	Mechanical malfunction (presumed)	-			
Fire engine (Chuetsu coast earthquake response)		△ (insufficient flow rate, difficulty in working)	Injection disabled as reactor depressurization function cannot be used	Submergence of 125V DC power supply panels due to tsunami	Same as (5)			
			Difficulty in ensuring the required coolant injection flow rate	Difficulty in ensuring the capacity of the fire protection water tank used as the water source	(13) Depletion of fresh water source			
	Obstacles due to the impact of the earthquake and tsunami		(14) Obstacles due to the earthquake and tsunami					
Site evacuation due to explosion in the Unit 1 Reactor Building and high radiation dose	(15) Deterioration in work environment due to hydrogen explosion and rise in radiation dose							
Sea water injection hose damaged due to explosion in the Unit 1 Reactor Building → relaying	Same as (15)							

Table 3.3-1 Analysis of cause of the accident at Fukushima Daiichi Nuclear Power Plant Unit 1 and Sorting of the problems (2/2)

Safety function	Related facility, etc.		Function loss or function degradation	Cause analysis	Problem		
				Intermittent aftershocks and continuous issue of large tsunami warnings	-		
				Loss of communication means due to loss of alternative power supply	Same as (9)		
Block up	Containment isolation	Main steam isolation valve	O	(Normal operation)	-		
	Function for removing heat from containment vessel	Containment vessel cooling system	X	Function loss due to blackouts	Submergence of 6.9 kV high pressure power supply panels due to tsunami	Same as (3)	
				Function loss due to loss of containment vessel cooling sea water system	Submergence of containment vessel cooling sea water pump due to the tsunami	Same as (10)	
		Shutdown cooling system	X	Function loss due to blackouts	Submergence of 6.9 kV high pressure power supply panels due to tsunami	Same as (3)	
				Function loss due to loss of DC power supply	Submergence of 125V DC power supply panels due to tsunami	Same as (5)	
				Function loss due to loss of component cooling sea water system	Submergence of cooling sea water pump due to the tsunami	Same as (11)	
		Alternative heat removal function	Alternative containment vessel spray with makeup water system (AM)	X	Function loss due to blackouts	Submergence of 480V low pressure power supply panels due to tsunami	Same as (4)
	Alternative containment vessel spray with fire protection system (AM)		X	Unable to use electric pump due to loss of external power supply	Receiving circuit breaker of Ookuma Line 2L in the switchyard of Unit 1/2 damaged due to the earthquake	Same as (1)	
				Diesel driven extinguishing pump shutdown	Mechanical malfunction (presumed)	-	
				Operation not implemented for alternative containment vessel spray	Priority for feed water and alternative coolant injection to emergency condenser (presumed)	-	
	Pressure withstanding reinforced vent (AM)		$\Delta$ (Time required due to blackout)	Difficulty in vent operation		Submergence of 125V DC power supply panels due to tsunami (Remote operation of air-operated containment vessel vent valve not possible)	Same as (5)
						Drop in pressure of Instrument Air due to loss of external power supply	(16) Difficulty in ensuring compressed air
						Unable to open the electric valve of cylinder line due to blackout and rise in radiation	Same as (4) and (15)
						Difficulty in accessing due to rise in radiation dose	Same as (15)
						Loss of communication means due to loss of alternative power supply	Same as (9)
	Drywell cooler (AM)		X	Function loss due to blackouts	Submergence of 480V low pressure power supply panels due to tsunami	Same as (4)	
		Function loss due to loss of component cooling sea water system		Submergence of component cooling sea water pump due to the tsunami	Same as (11)		
	Reactor coolant cleanup system (AM)	X	Function loss due to blackouts	Submergence of 480V low pressure power supply panels due to tsunami	Same as (4)		
			Function loss due to loss of component cooling sea water system	Submergence of component cooling sea water pump due to the tsunami	Same as (11)		
	Radioactive material release reduction function	Stand-by gas treatment system	X	Unable to operate due to loss of DC power supply	Submergence of 480V low pressure power supply panels due to tsunami	Same as (4)	
Other	Containment vessel	X	Leakage generation	Deterioration in the seal of flange gasket and penetration due to loss in the function for removing heat from containment vessel	(17) Heat resistance and pressure resistance of gasket and penetration seal		
	Reactor building	X	Damage due to hydrogen explosion	Hydrogen generation due to the reaction of zircaloy and water	-		
				Hydrogen leakage from containment vessel penetration part	-		
			Hydrogen retention in reactor building	(18) Hydrogen retention in reactor building			
Other	Important functions related to safety	Air heating and ventilating system in central control room	X	Function loss due to blackouts	Submergence of 480V low pressure power supply panels due to tsunami	Same as (4)	
	Function to determine the condition of the plant during an accident	Monitoring instruments at the time of an accident	X	Function loss due to loss of DC power supply	Submergence of 125V DC power supply panels due to tsunami	Same as (5)	
	Function to determine abnormal conditions	Communication equipment	X	Function loss due to blackouts	Submergence of 480V low pressure power supply panels due to tsunami	Same as (4)	
		Emergency lighting	X	Function loss due to blackouts	Submergence of 480V low pressure power supply panels due to tsunami	Same as (4)	
				Function loss due to loss of DC power supply	Submergence of 125V DC power supply panels due to tsunami	Same as (5)	

O: Normal operation;  $\Delta$ : Insufficient operation; X: Unable to operate; -: Operation not required

(Note) AM: Accident management (Severe accident measures)

Table 3.3-2 Analysis of cause of the accident at Fukushima Daiichi Nuclear Power Plant Unit 2 and Sorting of the problems (1/2)

Safety function	Related facility, etc.	Function loss or function degradation	Cause analysis	Problem			
Stoppage	Emergency reactor shut-down function	Safety protection system, control rod and control rod drive system ○	(Normal operation when earthquake occurred)	-	-		
	Alternative reactivity control	Recirculation pump trip (AM)	-	(Not required as scram was successful)	-		
		Alternative control rod insertion (AM)	-	(Not required as scram was successful)	-		
Sub-criticality maintenance function	Borated water injection system	-	(Not required as scram was successful)	-	-		
Support systems	Power supply function	External power source	X	Loss of external power supply due to the earthquake	Receiving circuit breaker of Ookuma Line 2L in the switchyard of Unit 1/2 damaged due to the earthquake Circuit breaker for Ookuma Line 2L in new Fukushima substation damaged	(1) Reliability of switchyard circuit breaker	
		Emergency diesel generator	X	Function loss due to submergence	Emergency diesel generator submerged in water due to the tsunami (2A) and power source panels submerged (2B)	(2) Submergence of the emergency diesel generator facility	
		6.9 kV high pressure power supply	X	Function loss due to submergence	Submergence of 6.9 kV high pressure power supply panels due to tsunami	(3) Submergence of 6.9 kV high pressure power supply panels	
		480V low pressure power supply	X	Function loss due to loss of 6.9 kV high pressure power supply	Submergence of 6.9 kV high pressure power supply panels due to tsunami	Same as (3)	
				Function loss due to partial submergence	Partial submergence of 480V low pressure power supply panels due to tsunami	(4) Submergence of 480V low pressure power supply panels	
	125V DC power supply	X	Function loss due to submergence	Submergence of 125V DC power supply panels due to tsunami	(5) Submergence of 125V low pressure power supply panels		
	Alternative power supply function	Power supply interchange (AM)	X	Power supply interchange unavailable from adjacent plants	Loss of station power of adjacent plant (Unit 1) due to tsunami	(6) Submergence of power supply panels of the adjacent plant	
		Power source car (emergency arrangement)	X	Difficulty in reaching	Difficulty in reaching due to damaged roads and traffic jams	(7) No deployment of alternative power supply	
				Difficulty in connection work	Difficulty in laying cables (weight, isolation, work environment)	(8) Alternative power supply cable laying	
				Power supply interruption	Intermittent aftershocks and continuous issue of large tsunami warnings Loss of communication means due to blackouts	(9) Communication means during blackouts	
	Auxiliary cooling function	Emergency diesel generator facility and cooling seawater system	X	Function loss due to submergence	Submergence of seawater pump for cooling the emergency diesel generator due to the tsunami	(10) Submergence of cooling sea water system for emergency diesel generator	
				Function loss due to blackouts	Submergence of 6.9 kV high pressure power supply panels due to tsunami	Same as (3)	
		Sea water system for residual heat removal system	X	Function loss due to submergence	Submergence of sea water pump for cooling the residual heat removal system due to the tsunami	(11) Submergence of sea water pump of the residual heat removal system	
				Function loss due to blackouts	Submergence of 6.9 kV high pressure power supply panels due to tsunami	Same as (3)	
		Sea water cooling system	X	Function loss due to submergence	Submergence of cooling sea water pump due to the tsunami	(12) Submergence of cooling sea water pump	
				Function loss due to blackouts	Submergence of 6.9 kV high pressure power supply panels due to tsunami	Same as (3)	
		Reactor component cooling water system	X	Function loss due to loss of DC power supply	Submergence of 125V DC power supply panels due to tsunami	Same as (5)	
				Function loss due to loss of component cooling sea water system	Submergence of cooling sea water pump due to the tsunami	Same as (12)	
	Cool down	Function to prevent over-pressurization of reactor coolant pressure boundary	Main steam relief safety valve (safety valve function)	○	(Normal operation)	-	-
		Reactor core isolation cooling system	△ (Operational for approx. 3 days)	Unable to control due to loss of DC power supply	Submergence of 125V DC power supply panels due to tsunami	Same as (5)	
		Alternative injection function (high pressure)	Borated water injection system (AM)	X	Function loss due to blackouts	Submergence of 6.9 kV high pressure power supply panels due to tsunami	Same as (3)
					Power supply interruption	[Recovery not possible] Cables damaged and power supply car stopped automatically due to explosion in the Unit 1 Reactor Building	-
			Control rod drive water system (AM)	X	Function loss due to blackouts	Unable to receive power due to loss of external power supply and unavailability of emergency diesel generator	Same as (1) - (3)
Reactor depressurization function		Main steam relief safety valve (relief valve function / automatic depressurization function)	X	Function loss due to loss of component cooling sea water system	Submergence of cooling sea water pump due to the tsunami	Same as (12)	
				Power supply interruption	[Recovery not possible] Cables damaged and power supply car stopped automatically due to explosion in the Unit 1 Reactor Building	-	
Low pressure core cooling function		Automatic depressurization function during transient (AM)	X	Function loss due to loss of DC power supply	Submergence of 125V DC power supply panels due to tsunami	Same as (5)	
				Function loss due to loss of DC power supply	Submergence of 125V DC power supply panels due to tsunami	Same as (5)	
		Core spray system	X	Injection disabled as reactor depressurization function cannot be used	Submergence of 125V DC power supply panels due to tsunami	Same as (5)	
				Function loss due to blackouts	Submergence of 6.9 kV high pressure power supply panels due to tsunami	Same as (3)	
				Function loss due to loss of DC power supply	Submergence of 125V DC power supply panels due to tsunami	Same as (5)	
		Residual heat removal system (low pressure coolant injection system)	X	Function loss due to loss of sea water system of residual heat removal system	Submergence of sea water pump for cooling the residual heat removal system due to the tsunami	Same as (11)	
				Injection disabled as reactor depressurization function cannot be used	Submergence of 125V DC power supply panels due to tsunami	Same as (5)	
				Function loss due to blackouts	Submergence of 6.9 kV high pressure power supply panels due to tsunami	Same as (3)	
				Function loss due to loss of sea water system of residual heat removal system	Submergence of sea water pump for cooling the residual heat removal system due to the tsunami	Same as (11)	
		Alternative injection function (low pressure)	Makeup water system (AM)	X	Injection disabled as reactor depressurization function cannot be used	Submergence of 125V DC power supply panels due to tsunami	Same as (5)
Function loss due to blackouts					Submergence of 6.9 kV high pressure power supply panels due to tsunami	Same as (3)	
Fire protection system (AM)			X	Injection disabled as reactor depressurization function cannot be used	Submergence of 125V DC power supply panels due to tsunami	Same as (5)	
				Unable to use the diesel driven extinguishing pump (presumed)	Cause unknown	-	
Fire engine (Chuetsu coast earthquake response)			△ (insufficient flow rate, difficulty in working)	Injection disabled as reactor depressurization function cannot be used	Submergence of 125V DC power supply panels due to tsunami	Same as (5)	
				Difficulty in ensuring the required coolant injection flow rate	Difficulty in ensuring the capacity of the fire protection water tank used as the water source	(13) Depletion of fresh water source	
				Difficulty in working	Obstacles due to the impact of the earthquake and tsunami	(14) Obstacles due to the earthquake and tsunami	
	Site evacuation due to explosion in the Unit 3 Reactor Building and high radiation dose				(15) Deterioration in work environment due to hydrogen explosion and rise in radiation dose		
	[Recovery not possible] Sea water injection hose damaged due to explosion in the Unit 3 Reactor Building→ relaying				Same as (15)		
Intermittent aftershocks and continuous issue of large tsunami warnings	-						
Loss of communication means due to loss of alternative power supply	Same as (8)						
Interruption in coolant injection because of no fuel	(16) Fuel supply for fire engine						
Containment isolation	Main steam isolation valve	○	(Normal operation)	-	-		

Table 3.3-2 Analysis of cause of the accident at Fukushima Daiichi Nuclear Power Plant Unit 2 and Sorting of the problems (2/2)

Safety function	Related facility, etc.		Function loss or function degradation	Cause analysis	Problem	
Block up	Function for removing heat from containment vessel	Residual heat removal system	X	Function loss due to blackouts	Submergence of 6.9 kV high pressure power supply panels due to tsunami	Same as (3)
				Function loss due to loss of sea water pumping function of residual heat removal system	Submergence of sea water pump for cooling the residual heat removal system due to the tsunami	Same as (10)
	Alternative heat removal function	Alternative containment vessel spray with makeup water system (AM)	X	Function loss due to blackouts	Submergence of 6.9 kV high pressure power supply panels due to tsunami	Same as (3)
					Unable to use electric pump due to loss of external power supply	2L receiving circuit breaker of Ookuma Line in the switchyard of Unit 1/2 damaged due to the earthquake
		Alternative containment vessel spray with fire protection system (AM)	X	Unable to use the diesel driven extinguishing pump (presumed)	Cause unknown	-
					Submergence of 125V DC power supply panels due to tsunami	Same as (5)
		Pressure withstanding reinforced vent (AM)	X	Vent unavailable	Drop in pressure of Instrument Air due to loss of external power supply	(17) Difficulty in ensuring compressed air
					Difficulty in accessing due to rise in radiation dose	Same as (15)
					Loss of communication means due to loss of alternative power supply	Same as (8)
					Large valves on suppression pool side closed due to explosion in the Unit 3 Reactor Building	-
					[Recovery not possible] Large valves on suppression pool side closed due to insufficient compressed air	Same as (17)
					[Recovery not possible] Large valves on suppression pool side closed due to malfunction of electromagnetic valve (presumed)	-
					Reconfiguration of system due to rise in drywell pressure and non-uniform pressure in pressure suppression chamber	-
					Inoperative rupture disk	(18) Inoperative rupture disk
		Drywell cooler (AM)	X	Function loss due to blackouts	Unable to receive power due to loss of external power supply and unavailability of emergency diesel generator	Same as (1) - (3)
					Function loss due loss of component cooling sea water system	Submergence of cooling sea water pump due to the tsunami
Reactor coolant cleanup system (AM)	X	Function loss due to blackouts	Unable to receive power due to loss of external power supply and unavailability of emergency diesel generator	Same as (1) - (3)		
			Function loss due loss of component cooling sea water system	Submergence of cooling sea water pump due to the tsunami	Same as (12)	
Radiation release reduction function	Stand-by gas treatment system	X	Unable to operate due to loss of DC power supply	Submergence of 6.9 kV high pressure power supply panels due to tsunami	Same as (3)	
Other	Containment vessel	X	Leakage generation	Pressure drop (cause unknown)	-	
	Reactor building	△	Blow out panel opening (no damage to the building)	Hydrogen retention prevention	-	
Other	Important functions related to safety	Air heating and ventilating system in central control room	X	Function loss due to blackouts	Submergence of 6.9 kV high pressure power supply panels due to tsunami	Same as (3)
	Function to determine the condition of the plant during an accident	Monitoring instruments at the time of an accident	X	Function loss due to blackouts	Submergence of 6.9 kV high pressure power supply panels due to tsunami	Same as (3)
	Function to determine abnormal conditions	Communication equipment	X	Function loss due to blackouts	Submergence of 6.9 kV high pressure power supply panels due to tsunami	Same as (3)
		Emergency lighting	X	Function loss due to blackouts	Submergence of 6.9 kV high pressure power supply panels due to tsunami	Same as (3)
				Function loss due to loss of DC power supply	Submergence of 125V DC power supply panels due to tsunami	Same as (5)

O: Normal operation; △: Insufficient operation; X: Unable to operate; -: Operation not required

(Note) AM: Accident management (Severe accident measures)

Table 3.3-3 Analysis of cause of the accident at Fukushima Daiichi Nuclear Power Plant Unit 3 and Determining the problems (1/2)

Safety function		Related facility, etc.	Function loss or function degradation		Cause analysis	Problem
Stoppage	Emergency reactor shut-down function	Safety protection system, control rod and control rod drive system	○	(Normal operation when earthquake occurred)	-	-
	Alternative reactivity control	Recirculation pump trip (AM)	-	(Not required as scram was successful)	-	-
		Alternative control rod insertion (AM)	-	(Not required as scram was successful)	-	-
Sub-criticality maintenance function	Borated water injection system	-	(Not required as scram was successful)	-	-	
Support systems	Power supply function	External power source	X	Loss of external power supply due to the earthquake	Damage to external substation facilities due to the earthquake	(1) Reliability of switchyard equipment
		Emergency diesel generator	X	Function loss due to submergence	Submergence of emergency diesel generator due to the tsunami	(2) Submergence of the emergency diesel generator
		6.9 kV high pressure power supply	X	Function loss due to submergence	Submergence of 6.9 kV high pressure power supply panels due to tsunami	(3) Submergence of 6.9 kV high pressure power supply panels
		480V low pressure power supply	X	Function loss due to loss of 6.9 kV high pressure power supply	Submergence of 6.9 kV high pressure power supply panels due to tsunami	Same as (3)
				Function loss due to submergence	Submergence of 480V low pressure power supply panels due to tsunami	(4) Submergence of 480V low pressure power supply panels
	125V DC power supply	△ (Will deplete later)	(Normal operation)	Use of DC power supply exceeding the available supply time	(5) Depletion of DC power source	
	Alternative power supply function	Power supply interchange (AM)	X	Power supply interchange unavailable from adjacent plants	Loss of station power of adjacent plant (Unit 4) due to tsunami	(6) Submergence of power supply panels of the adjacent plant
		Power source car (emergency arrangement)	X	Difficulty in reaching	Difficulty in reaching due to damaged roads and traffic jams	(7) Procurement of alternative power supply from outside
				Difficulty in connection work	Unable to connect due to submergence of AC power supply	Same as (3), (4)
					Difficulty in laying cables (weight, isolation, work)	(8) Alternative power supply cable laying
				Loss of communication means due to loss of alternative power supply	(9) Communication means during blackouts	
	Power supply interruption	Cables damaged and power supply car stopped automatically due to explosion in the Unit 1 Reactor Building	-			
	Auxiliary cooling function	Emergency diesel generator facility and cooling seawater system	X	Function loss due to submergence	Submergence of seawater pump for cooling the emergency diesel generator due to the tsunami	(10) Submergence of cooling sea water pump for emergency diesel generator
				Function loss due to blackouts	Submergence of 6.9 kV high pressure power supply panels due to tsunami	Same as (3)
		Sea water system for residual heat removal system	X	Function loss due to submergence	Submergence of sea water pump for cooling the residual heat removal system due to the tsunami	(11) Submergence of sea water pump of the residual heat removal system
				Function loss due to blackouts	Submergence of 6.9 kV high pressure power supply panels due to tsunami	Same as (3)
		Sea water cooling system	X	Function loss due to submergence	Submergence of cooling sea water pump due to the tsunami	(12) Submergence of component cooling sea water pump
				Function loss due to blackouts	Submergence of 6.9 kV high pressure power supply panels due to tsunami	Same as (3)
		Reactor component cooling water system	X	Function loss due to loss of component cooling sea water system	Submergence of cooling sea water pump due to the tsunami	Same as (12)
				Function loss due to blackouts	Submergence of 6.9 kV high pressure power supply panels due to tsunami	Same as (3)
Cool down	Function to prevent over-pressurization of reactor coolant pressure boundary	Main steam relief safety valve (safety valve function)	○	(Normal operation)	-	-
	High pressure core cooling function	High pressure core injection system	△	Function loss due to loss of DC power supply	Use of DC power supply exceeding the available supply time	Same as (5)
		Reactor core isolation cooling system	△	Function loss due to loss of DC power supply	Use of DC power supply exceeding the available supply time	Same as (5)
	Alternative injection function (high pressure)	Borated water injection system (AM)	X	Function loss due to blackouts	Submergence of 480V low pressure power supply panels due to tsunami	Same as (4)
				Difficulty in power supply recovery operation	[Recovery not possible] Power supply recovery difficult due to aftershocks and poor working environment	-
		Control rod drive water system (AM)	X	Function loss due to blackouts	Submergence of 480V low pressure power supply panels due to tsunami	Same as (4)
	Reactor depressurization function	Main steam relief safety valve (relief valve function / automatic depressurization function)	△	Function loss due to loss of component cooling sea water system	Submergence of cooling sea water pump due to the tsunami	Same as (12)
				Automatic depressurization function during transient	△	Function loss due to loss of DC power supply
	Low pressure core cooling function	Core spray system	X	Injection disabled as reactor depressurization function cannot be used	Use of DC power supply exceeding the available supply time	Same as (5)
				Function loss due to blackouts	Submergence of 6.9 kV high pressure power supply panels due to tsunami	Same as (3)
		Residual heat removal system (low pressure coolant injection system)	X	Function loss due to loss of sea water system of residual heat removal system	Submergence of sea water pump for cooling the residual heat removal system due to the tsunami	Same as (5)
				Function loss due to blackouts	Submergence of 6.9 kV high pressure power supply panels due to tsunami	Same as (11)
	Alternative injection function (low pressure)	Makeup water system (AM)	X	Injection disabled as reactor depressurization function cannot be used	Use of DC power supply exceeding the available supply time	Same as (5)
				Function loss due to blackouts	Submergence of 480V low pressure power supply panels due to tsunami	Same as (4)
		Fire protection system (AM)	X	Injection disabled as reactor depressurization function cannot be used	Use of DC power supply exceeding the available supply time	Same as (5)
				Insufficient flow rate of the required coolant injection	Difficulty in ensuring the capacity of the fire protection water tank used as the water source	(14) Depletion of fresh water source
		Fire engine (Chuetsu coast earthquake response)	△ (insufficient flow rate, delay)	Obstacles due to the impact of the earthquake and tsunami	(15) Obstacles due to the earthquake and tsunami	
				Site evacuation due to explosion in the Unit 3 Reactor Building and high radiation dose	(16) Deterioration in work environment due to hydrogen explosion and rise in radiation dose	
				Difficulty in coolant injection	Sea water injection hose damaged due to explosion in the Unit 3 Reactor Building → relaying	Same as (16)
				Intermittent aftershocks and continuous issue of large tsunami warnings	-	

Table 3.3-3 Analysis of cause of the accident at Fukushima Daiichi Nuclear Power Plant Unit 3 and Determining the problems (2/2)

Safety function	Related facility, etc.	Function loss or function degradation	Cause analysis	Problem		
			Loss of communication means due to loss of alternative power supply	Same as (9)		
Block up	Containment isolation	Main steam isolation valve	△	Operation (generation of isolation signal related to break before and after the main steam isolation valve closure)	-	
	Function for removing heat from containment vessel	Containment vessel cooling system	X	Function loss due to loss of sea water system of residual heat removal system	Submergence of sea water pump for cooling the residual heat removal system due to the tsunami	Same as (11)
				Function loss due to blackouts	Submergence of 6.9 kV high pressure power supply panels due to tsunami	Same as (3)
	Alternative heat removal function	Alternative containment vessel spray with makeup water system (AM)	X	Function loss due to blackouts	Submergence of 480V low pressure power supply panels due to tsunami	Same as (4)
				△	Unable to use the electric pump due to loss of power supply. Diesel pump temporarily operational	Submergence of switchyards of Units 3/4 due to tsunami
		Containment vessel vent (AM)	△	Difficulty in vent operation	Use of DC power supply exceeding the available supply time	Same as (5)
					Drop in pressure of Instrument Air due to loss of external power supply	Same as (1)
					Difficulty in accessing due to rise in radiation dose	Same as (16)
					Loss of communication means due to loss of alternative power supply	Same as (9)
		Drywell cooler (AM)	X	Function loss due to blackouts	Submergence of 480V low pressure power supply panels due to tsunami	Same as (4)
				Function loss due loss of component cooling sea water system	Submergence of cooling sea water pump due to the tsunami	Same as (11)
	Reactor coolant cleanup system (AM)	X	Function loss due to blackouts	Submergence of 480V low pressure power supply panels due to tsunami	Same as (4)	
			Function loss due loss of component cooling sea water system	Submergence of cooling sea water pump due to the tsunami	Same as (11)	
	Radioactive material release reduction function	Stand-by gas treatment system	X	Unable to operate due to loss of DC power supply	Submergence of 480V low pressure power supply panels due to tsunami	Same as (4)
	Multiple barrier function	Containment vessel	X	Leakage generation	Deterioration in the seal of flange gasket and penetration due to loss in the function for removing heat from containment	(17) Heat resistance and pressure resistance of gasket and penetration seal
Reactor building		X	Damage due to hydrogen explosion	Hydrogen generation due to the reaction of zircaloy and water	-	
			Hydrogen retention in reactor building	Hydrogen leakage from containment vessel penetration part	-	
Other	Important functions related to safety	Air heating and ventilating system in central control room	X	Function loss due to blackouts	Submergence of 480V low pressure power supply panels due to tsunami	Same as (4)
	Function to determine the condition of the plant during an accident	Monitoring instruments at the time of an accident	X	Function loss due to loss of DC power supply	Use of DC power supply exceeding the available supply time	Same as (5)
	Function to determine abnormal conditions	Communication equipment	X	Function loss due to blackouts	Submergence of 480V low pressure power supply panels due to tsunami	Same as (4)
		Emergency lighting	X	Function loss due to blackouts	Submergence of 480V low pressure power supply panels due to tsunami	Same as (4)
Function loss due to loss of DC power supply	Use of DC power supply exceeding the available supply time			Same as (5)		

O: Normal operation; △: Insufficient operation; X: Unable to operate; -: Operation not required  
 (Note) AM: Accident management (Severe accident measures)

### 3.3.1.1 Problems by function

#### (1) "Stopping" function

##### a. Emergency reactor shut-down function of the reactors

The reactors scrammed normally due to occurrence of the earthquake. The emergency reactor shut-down function of the reactors has not been lost in the safety protection system and control rod drive system.

##### b. Sub-criticality maintenance function

Normal scram of the reactors prevented a request of the function for control of alternative reactivity rate (control of reactivity rate by recirculation pump trip and alternative control rod insertion).

However, the recirculation pump tripped due to loss of external power source.

##### c. Sub-criticality maintenance function

Normal scram of the reactors prevented a request of the function for sub-criticality maintenance by SLC.

As mentioned above, since the "stopping" function operated normally or the function was not requested, no cause and no problem exist.

#### (2) "Cooling" function

##### a. Function to prevent over-pressurization in the reactor coolant pressure boundary

Signs of loss of reactor coolant by the earthquake were not found from the maintenance of main steam flow rate or temperature change in the containment air handling system after the earthquake.

In unit 1, no request was made to perform the safety valve function of SRV because IC controlled the reactor pressure after MSIV was closed.

In unit 2 and 3, SRV stably controlled the reactor pressure with the relief valve function or safety valve function after MSIV was closed, and performed its function normally.

##### b. High pressure core cooling function

###### (a) High pressure core injection system

For water levels of reactors after the scram, unit 1 to 3 were not given functional requests for HPCI operation request, but HPCI was put in the stand-by state. After that, arrival of the tsunami caused unit 1 and 2 to lose their functions due to loss of 125 VDC power. In unit 3, since the DC power supply system avoided flood, RCIC and HPCI could be used. With the reduction of water level in the reactors, the HPCI automatically started and the water level of the reactors was retained for a while. However, it then stopped and the function for coolant injection to the reactors was lost. This was caused by the exhaustion of DC power supply.

###### (b) Emergency condenser (unit 1 only)

High pressure in the reactor automatically started the IC after MSIV was closed. After that, the power was lost due to the tsunami during the reactor pressure control operation by the IC. Since loss of the control power supply (DC power supply) of IC due to the tsunami prevented confirming the open/close state of IC valve, and the indicator lamps of HPCI were OFF, the

startup was judged impossible. According to an investigation after that, there is a possibility that deenergizing the detection circuit of break in pipe, normally made up of an excitation circuit, could originate an isolation signal, automatically closing valves of the IC. Almost simultaneous loss of all AC power supplies may have caused the isolation valve inside the reactor containment, driven by AC power supply, to stop closing with the valve half opened (the clear opening is unknown). When DC power supply was temporarily recovered around 18:00 on March 11 (reason for the recovery is unknown), the isolation valve outside the reactor containment was opened. However, the degree of IC's core cooling function is unknown according to the opening of the isolation valve outside the reactor containment. There seems to be a high possibility that the IC's function may have been lost until the temporary recovery of DC power supply after the arrival of the tsunami.

As a facility for supplying coolant to the IC, FP called a makeup water system purified (hereinafter referred to as "MUWP") is provided. However, loss of the low voltage power supply of 480 V caused it to lose its function. The FP is divided into a motor pump and a diesel pump. The motor pump lost its function due to the loss of AC power supply. It is confirmed that the diesel driven pump ran temporarily but stopped due to malfunction. The contents of the malfunction are unknown.

**(c) Reactor core isolation cooling system (unit 2/3)**

After the scram, manual startup of the RCIC, automatic stop due to increase of reactor water level, and manual startup were repeated to control the reactor water level.

In unit 2, the operation state of the RCIC was not confirmed. At around 3:00 on March 12, however, discharge pressure of the RCIC pump was confirmed, and the pump is judged to have been running. After that, the water source was switched from CST to S/C to perform the operation. After 13:00 on March 14, the water level of the reactor tended toward decreasing, and the function of the RCIC was judged to have lost the function at 13:25. As a result, the RCIC of unit 2 is considered to have worked for approximately 3 days. It seems that loss of the power supply set the valve of the RCIC to work "as is" and the valve happened to open with the timing of loss of the power supply.

In unit 3, since the DC power supply was not affected by the tsunami, the RCIC and HPCI, operable with DC power supply, were usable. Unnecessary load was isolated to expand the operating time of batteries. At 11:36 on March 12, the RCIC automatically stopped and the HPCI automatically started up. At 2:42 on March 13, the HPCI automatically stopped and lost its function of injecting coolant to the reactor. As a result, coolant was injected to unit 3 for approximately 1.5 days until the exhaustion of the battery capacity.

**c. High pressure alternate injection function (countermeasure for severe accident)**

**(a) Stand-by liquid control system**

The function was lost due to loss of the power supplied from the low voltage power supply of 480 V necessary for the operation of the stand-by liquid control pump in unit 1 to 3. Since the power panel of the stand-by liquid control system and the main body of the stand-by liquid control were

not affected by the tsunami, power supply operation from the power supply car, arranged urgently after the loss of all AC power supplies, were carried out. However, because hydrogen explosion in the reactor building of unit 1 damaged the cable that had been laid, the power supply car arranged urgently stopped automatically, and then the SLC function was not recovered.

**(b) Control rod drive water system**

The function was lost due to loss of the power supplied from the low voltage power supply of 480 V necessary for the operation of the drive water pump in unit 1 to 3.

**d. Reactor depressurization function**

**(a) Main steam relief safety valve (manual relief function and automatic depressurization function)**

The manual relief operation and automatic depressurization function were lost because unit 1 to 3 lost its power supplied from the 125 V DC power supply necessary for the operation. As the result, the reactor pressure remained high, systems/facilities having the low pressure core cooling function could not inject coolant into the reactors. However, since the systems having the low pressure core cooling function lost its power supplies when all AC power supplies were lost, they lost the reactor injection function.

Since unit 2 required the depressurization of the reactor for fire engines to inject coolant to the reactor, temporary batteries were used to assure the power supply necessary for SRV to operate, so that the reactor was depressurized.

**e. Low pressure core cooling function**

**(a) Core spray system**

In unit 1 to 3, the core spray pump lost its function due to loss of the power supplied from the high voltage power supply of 6.9kV necessary for the operation of the core spray pump.

**(b) Low pressure coolant injection system (residual heat removal system) (unit 2/3)**

The residual heat removal pump (low pressure coolant injection mode) lost its function due to loss of the power supplied from the high voltage power supply of 6.9 kV necessary for the operation of the residual heat removal pump.

**f. Low pressure alternate injection function (countermeasure for severe accident)**

**(a) Makeup water system**

In unit 1 to 3, the makeup water pump lost its function due to loss of the power supplied from the low voltage power supply of 480 V necessary for the operation of the makeup water pump.

**(b) Fire protection system**

The fire protection system pump lost its function due to loss of the power supplied from the low voltage power supply of 480 V necessary for the

operation of the fire protection system pump. In addition to motor driven system pumps, diesel driven pumps were used as fire protection system pumps. In unit 1, it is confirmed that they ran temporarily but stopped due to malfunction. In unit 2, startup operation seems not to have been performed. However, details are unknown, e.g., whether the operation was not done due to failures. In unit 3, pumps ran temporarily but then stopped. Details are unknown.

Alternate coolant injection was carried out using fire engines prepared as a countermeasure taken after the Chuetsu Offshore Earthquake. However, since the volume of the fire protection tank used as a water source was limited, the required volume of coolant was insufficient and, therefore, preparations were made for the injection of sea water. Operations for the injection of coolant into the reactors had difficulties caused by obstacles produced by impact of the earthquake and tsunami, evacuation from the field site due to explosion of the reactor building of unit 1, high-dose debris, relaying of sea water injection hoses replaced with damaged ones, consecutive aftershocks, continuation of large tsunami warning, loss of communication methods due to loss of AC power supply, etc. In unit 2, fire engines started sea water injection after the reactor depressurization. However, since they ran out of fuel and stopped, injection of coolant to the reactor was suspended.

### **(c) Containment & vessel cooling water system**

The containment & vessel cooling water pump (unit 2/3 was put in the containment & vessel cooling mode for RHR pump) lost its function, because the power supplied from the high voltage power supply of 6.9 kV and the 125 VDC power supply necessary for the operation on the containment & vessel cooling water pump were unavailable or because the pump could not be started up due to flooding of the containment & vessel cooling sea water system (residual heat removal cooling sea water system in unit 2/3) and loss of the power supply.

For the reasons above, problems on the "cooling" function by facility are as follows.

- Submergence of power supply systems
- Exhaustion of sea water pump
- Exhaustion of fresh-water source
- Deterioration of working environments due to hydrogen explosion/increase of radiation dosage
- Obstacles caused by the earthquake and tsunami
- Loss of communication methods during loss of AC power supply
- Refueling of fire engines
- Exhaustion of DC power supply
- Origination of IC isolation signal with DC power supply lost

### **(3) "Confining" function**

#### **a. Reactor containment isolation function**

For unit 1 to 2, the MSIV is normally closed by the isolation signal generated due to loss of external power source. No leakage occurs in the main steam piping because the flow rate of main steam is zero after the MSIV is closed and because the reactor pressure has been increased.

The reactor containment isolation function works normally immediately after the occurrence of scram, and there are no causes of accidents or problems.

**b. Heat removal function from the containment**

CCS (unit 1: CCS, unit 2/3: RHR containment cooling mode) was started up manually after the scram, and unit 2 was started up manually to cool water in the S/C pool. After that, the CCS pump lost its function due to loss of the power supplied from the high voltage power supply of 6.9 kV necessary for the operation of the CCS pump. Unit 3 was not started up due to loss of power supply.

**c. Alternative cooling function (facilities for countermeasures for severe accident)**

**(a) Alternative containment spray by the makeup water system**

The makeup water system pump lost its function due to loss of the power supplied from the low voltage power supply of 480 V necessary for the operation of the makeup water system pump.

**(b) Alternative containment spray by the fire protection system**

The fire protection pump lost its function due to loss of the power supplied from the low voltage power supply of 480 V necessary for the operation of the fire protection pump. In addition to motor driven system pumps, diesel driven pumps were used as fire protection system pumps. For the situation, refer to the description in f. "**Low pressure alternate injection function (countermeasure for severe accident).**"

**(c) Containment vessel pressure reinforcement vent**

The vent to be performed based on the primary operation procedure could not be done because no power was supplied from 125 VDC power supplies necessary for the operation and the air pressure for instrumentation was decreased.

For unit 1 and 3, an attempt was made to perform manual release operation. However, the operations had difficulties because access was difficult caused by increase of radiation dosage or by loss of communication methods due to loss of AC power supply. As a result, vent is considered to have been done because the pressure of the containment was decreased.

In unit 1, when operations for opening vent valves of S/C (small valve) were performed several times in expectation of residual pressure of compressed air for instrumentation, the indication value of MP increased. Immediately after that, the indication value of MP radiation dosage decreased. It was therefore confirmed that there was a possibility that the vent might not be effective. The cause of this is assumed to be that the vent valves of the containment were closed immediately because the residual air pressure for instrumentation was little and the valves could not be kept open. Considering the vent of the containment of unit 1 to take precedence over that of the other reactors, the Minister of Economy, Trade and Industry issued an order to vent it at 6:50 on March 12. After the Prime Minister's visit to Okuma Town (Kuma area), confirmation of evacuation, etc., the reactor was vented at 9:15.

Although unit 3 also had difficulties in operation, the vent was judged to have been done. After that, since the air pressure and power supplies were not retained, valve opening operations were conducted several times.

In unit 2, the pressure of S/C remained lower than the working pressure of the rupture disk. On the other hand, the release operation was carried out for line configuration because the pressure of D/W was increasing. However, the pressure of D/W decreased around 6:00. For the reasons above, the implementation state of venting the containment of unit 2 is not clear at the current stage.

The pressure of D/W increased, while the pressure of /C decreased. However, the factor for indicating such behaviors is unknown at the current stage.

**(d) Alternative heat removal (countermeasure for severe accident) by dry well cooler and reactor coolant cleanup system**

In each case, the function was lost because the power was not supplied from the low voltage power supply of 480 V and the reactor component cooling water system stopped.

**d. Function for reducing the discharge of radio-active materials**

The SGTS lost its function because the power was not supplied from the low voltage power supply of 480 V.

**e. Others**

Since the heat removal function from the primary containment vessel (hereinafter referred to as "PCV") was lost, and temperature/pressure of the containment atmosphere increased excessively, the gasket of flange area and seal of the penetration are assumed to have deteriorated, causing the leakage. It is conjectured that, since leaked hydrogen from this penetration of the containment was retained in the reactor building, and increase of hydrogen concentration exceeded the flammability limit, hydrogen explosion occurred.

In the reactor building of unit 2, the blowout panel opened is conjectured to have prevented retaining hydrogen in it.

For the reasons above, problems on the "confining" function by facility are as follows.

- Submergence of power supply systems
- Submergence of sea water pump
- Deterioration of working environments due to hydrogen explosion/increase of radiation dosage
- Sealing property in a state exceeding the design conditions of gasket and seal of the penetration
- Retention of hydrogen in the reactor building
- Assurance of compressed air to keep the vent valves of the containment open
- Non-operation of rupture disk for venting the containment at low pressures

#### **(4) Basic requirements for implementing the operation (facility environments)**

##### **a. Habitability of the central control unit**

When the accident occurred, the air heating and ventilating system to assure the habitability of the MCR lost its function because the power was not supplied from the low voltage power supply of 480 V.

##### **b. Function of seizing the status of the station at the time of an accident**

The monitoring instruments at the time of an accident, which was a function of seizing the status of the station at time of an accident, lost the function, because DC power for instrumentation was not supplied to unit 1 and the power from the low voltage power supply of 480 V was not supplied to 2 and 3.

##### **c. Functions of seizing an abnormal state**

Communication equipment and emergency lighting, which were functions for seizing abnormal states, lost their functions, because power was supplied neither from the low voltage power supply of 480 V nor 125 VDC power supply.

For the reasons above, the following items are listed as the basic requirements for implementing the operation (facility environments).

- Submergence of power supply systems
- Exhaustion of DC power supply

#### **3.3.1.2 Problems related to common factors/failures**

Extracted problems by function in 3.3.1.1 include "without power supplied from power supply system" and "stoppage of cooling water system." Therefore, analysis of the causes and extraction of problems were furthermore carried out in terms of "power supply" and "auxiliary component cooling function."

#### **(1) Power supply function**

##### **a. External power source**

All unit 1 to 4 receive power supplied from external power sources via the Shin-Fukushima Transforming Station. The power supplies were lost caused by, e.g., damages of facilities in the transforming station due to the earthquake, damages of power receiving breakers and disconnecting switches within the switchyard of the station due to the earthquake, and operations of protective devices due to contact between power transmission lines and steel towers due to the earthquake. In addition to the damages due to the earthquake, the switchyards for unit 3 and 4 became difficult to recover external power sources at an early date because they were flooded by the tsunami.

##### **b. Emergency diesel generator**

After the loss of the external power sources, unit 1 to 3 automatically started up emergency DGs to supply power to the emergency bus. After that, however, the tsunami flooded them (although the main unit of 2BDG escaped the tsunami-caused damages, the high voltage power panel of 6.9 kV was flooded), they lost their functions, and the reactors then lost all AC power supplies.

### **c. On-site power**

The high voltage power supply of 6.9 kV lost its function because the power panel was flooded. Therefore, the low voltage power supply of 480 V, used as the load, also lost its function. The 480 V power panels for unit 1 and 3 were also flooded.

The 125 VDC power for unit 1 and 2 could not be supplied from batteries, because the 125 VDC power panel was flooded by the tsunami. The 125 VDC power panel for unit 3 escaped the flood. After the batteries worked for several days, they were exhausted and lost the function.

### **d. Alternative power supply function**

Loss of all AC power supplies prevented the power interchange from adjacent reactors, which had been prepared as a countermeasure for severe accidents.

Operations for laying and connecting cables were extremely difficult for various reasons, e.g., delay in arrival of power supply cars arranged urgently after the loss of all AC power supplies due to damages of roads caused by the earthquake and traffic congestions, submergence of all AC power panels, weight of cables, laying distance, poor working conditions, intermittent aftershocks, continuation of large tsunami warning, and loss of communication methods. In addition, hydrogen explosion in the reactor building damaged laid cables, and the power supply cars stopped automatically.

For the reasons above, problems on power supply functions by facility are listed as follows.

- Reliability of external power sources against earthquakes and tsunami
- Reliability of breakers in switchyards when earthquakes occur
- Submergence of power supply systems
- Procurement of alternative power supplies from outside
- Laying of cables for alternative power supplies
- Communication methods during the loss of AC power supply

## **(2) Auxiliary component cooling function**

Immediately after the external power sources were lost due to the earthquake, the sea water systems requiring the auxiliary component cooling function received power from the emergency DG and operated normally. However, since the sea water pump was flooded due to the tsunami, and the high voltage power panel of 6.9 kV for supply power was flooded, the function was lost.

For the reasons above, problems on the auxiliary component cooling function by facility are listed as follows.

- Submergence of sea water pump
- Submergence of power supply systems

Electric power systems and auxiliary component cooling systems are facilities having highly important safety functions. Since all the systems lost the functions at a time due to the tsunami, the accident was enlarged. The facilities of countermeasures against failures could not put the expansion of

the accident under control, because they lost their functions due to the loss of electric power systems and auxiliary component cooling systems.

For the reasons above, the following problems can be listed as countermeasures against severe accidents for power supply systems and auxiliary component cooling systems.

- Prevention of tsunami from damaging all facilities a time.
- Means of preventing tsunami from affecting (breakwater, or deployment in rising ground, etc.) has been prepared so that damages by tsunami can be avoided.

### **3.4 Causal analysis of the accident in unit 4 and management of issues**

Causes of the loss of cooling function of the spent fuel pool and the hydrogen explosion in Fukushima Daiichi Unit 4 are summarized. The result of the causal analysis of the accident in Unit 4 and the management of the issues is shown in Table 3.4-1.

After the earthquake occurred, loss of an external power source, that is a station blackout, occurred that was caused by loss of emergency DG due to the tsunami. The DC power source and a sea water pump were also lost.

**Table 3.4-1 Analysis of cause of the accident at Fukushima Daiichi Nuclear Power Plant Unit 4 and Determining the problems (1/1)**

Safety function		Related facility, etc.	Function loss or function degradation	Cause analysis	Problem		
Support system	Power supply function	External power source	X	Loss of external power supply due to the earthquake	Damage to external substation facilities due to the earthquake	(1) Reliability of switchyard equipment	
		Emergency diesel generator	X	1 out of the 2 installed generators is under routine inspection. The remaining generator cannot be used as the power supply panels are submerged (the emergency diesel generator is not submerged in water).	Submergence of 6.9 kV high pressure power supply panels due to tsunami	(2) Submergence of 6.9 kV high pressure power supply panels	
		6.9 kV high pressure power supply	X	Function loss due to submergence	Submergence of 6.9 kV high pressure power supply panels due to tsunami	Same as (2)	
		480V low pressure power supply	X	Function loss due to submergence (only power supply panels installed in auxiliary public facilities in operation)	Submergence of 480V low pressure power supply panels due to tsunami	(3) Submergence of 480V low pressure power supply panels	
		125V DC power supply	X	Function loss due to submergence	Submergence of 125V DC power supply panels due to tsunami	(4) Submergence of 125V low pressure power supply panels	
	Auxiliary cooling function	Sea water system for residual heat removal system	X	Function loss due to submergence	Submergence of sea water pump for cooling the residual heat removal system due to the tsunami	(5) Submergence of sea water pump of the residual heat removal system	
				Function loss due to blackouts	Submergence of 6.9 kV high pressure power supply panels due to tsunami	Same as (2)	
		Sea water cooling system	X	Function loss due to submergence	Submergence of cooling sea water pump due to the tsunami	(6) Submergence of component cooling sea water pump	
				Function loss due to blackouts	Submergence of 6.9 kV high pressure power supply panels due to tsunami	Same as (2)	
		Reactor component cooling water system	X	Function loss due to loss of component cooling sea water system	Submergence of cooling sea water pump due to the tsunami	Same as (6)	
				Function loss due to blackouts	Submergence of 6.9 kV high pressure power supply panels and 480V low pressure power supply panels due to tsunami	Same as (3), (4)	
		Cooling of used fuel pools	Cooling function	Fuel pool cooling system	X	Function loss due to blackouts	Submergence of 6.9 kV high pressure power supply panels and 480V low pressure power supply panels due to tsunami
	Residual heat removal system			X	Function loss due to loss of sea water system of residual heat removal system	Submergence of sea water pump for cooling the residual heat removal system due to the tsunami	Same as (5)
			Function loss due to blackouts		Submergence of 6.9 kV high pressure power supply panels due to tsunami	Same as (2)	
Sodium injection function	Makeup water supply system		X	Function loss due to blackouts	Submergence of 6.9 kV high pressure power supply panels and 480V low pressure power supply panels due to tsunami	Same as (3), (4)	
				Block up	Reactor building	X	Damage due to hydrogen explosion
			Inflow of vent gas in Unit 3	(8) Wraparound of hydrogen gas in units that share the vent stack			

O: Normal operation; Δ: Insufficient operation; X: Unable to operate; -: Operation not

## **(1) Loss of cooling function of the spent fuel pool**

### **a. Spent fuel pool cooling function**

The FPC that had been operating right before the earthquake occurred stopped because the external power source was lost due to the earthquake. After that, the SFP cooling function was lost because the function of the component cooling water system was lost due to the Tsunami and the 480V low voltage power source that is necessary for the operation of the FPC was lost.

The RHR that had been operating right before the earthquake occurred stopped because the external power source was lost due to the earthquake. After that, the SFP cooling function was lost because the function of the RHR sea water system was lost due to the tsunami and the 6.9kV high voltage power source that is necessary for the operation of the RHR was lost.

The MUWC has a function of supplying water to the SFP. However, its function was lost because the 480V low voltage power source that is necessary for the operation of the MUWC was lost.

As a result, the issues of the respective facility regarding the SFP cooling function were as follows.

- Soaking of the sea water pump
- Soaking of the power source facility

## **(2) Hydrogen explosion**

### **a. Main cause of hydrogen generation**

An explosion that is considered to be due to hydrogen occurred in the reactor building of Unit 4 at about 6 am on March 15.

When the earthquake occurred, Unit 4 was stopped because it was undergoing a periodic inspection, and all fuel was taken out from the reactor to the spent fuel pool. Because of this, there was no possibility of hydrogen generation from the reactor. As a result of observing the fuel in the pool by camera, it can be assumed that damage of the fuel was not found, and that there was no large-scale damage of the fuel from the result of analyzing nuclides of the fuel pool water taken from the fuel pool of Unit 4. Consequently, the possibility of generating a large amount of hydrogen in the fuel pool of Unit 4 was low.

On the other hand, the SGTS exhaust pipe of Unit 4 joined with the SGTS exhaust pipe of Unit 3 before the vent stack. There is a possibility that the hydrogen explosion occurred as a result of the hydrogen in the PCV of Unit 3 flowing into the R/B of Unit 4 through the SGTS exhaust pipe via a container vent that was carried out in Unit 3, and the hydrogen was retained. The radiation dose of the SGTS filter train of Unit 4 was measured, and it was found that the radiation dose was high on the exit side and got lower going toward the entrance side.

As a result, the issues of the respective facility regarding the hydrogen explosion in Unit 4 are as follows.

- Hydrogen retention in the reactor building
- Wrapping around of hydrogen gas between the units that share the vent stack
- Wrapping around from the container vent line to the building

### **3.5 Management of the events in units 5 and 6**

Because the reactors of Units 5 and 6 were not working and there was enough time for correspondence, the power source was successfully accommodated from the DG (6B) whose function was not lost due to the tsunami and alternative coolant injection was successful. Conclusively, the residual heat removal function by the temporary sea water pump was able to recover.

The progress of the events of Fukushima Daiichi Units 5 and 6 is shown in Figure 3.5-1 using an event tree.

Accidents were successfully prevented from extending in Units 5 and 6 by directly connecting a power source of one air-cooled emergency DG to a safety component, and it is considered that safety can be ensured when the power source is secure.

Hence, having variety of cooling types of the emergency DG and having a variety of installation sites from the viewpoint of soaking can become effective countermeasures.

However, it should be kept in mind that there was a necessity of supplying power by directly drawing a cable from a bus of the emergency DG to the safety component because the power panel was affected by the tsunami. Because the distribution of electricity to a plurality of the safety components will be simultaneously lost when the power panel is submerged, it is necessary to investigate a plan for supplying power to the necessary components from the available power sources even when soaking occurs while ensuring soaking countermeasures in order to increase the security of the dependable power source.

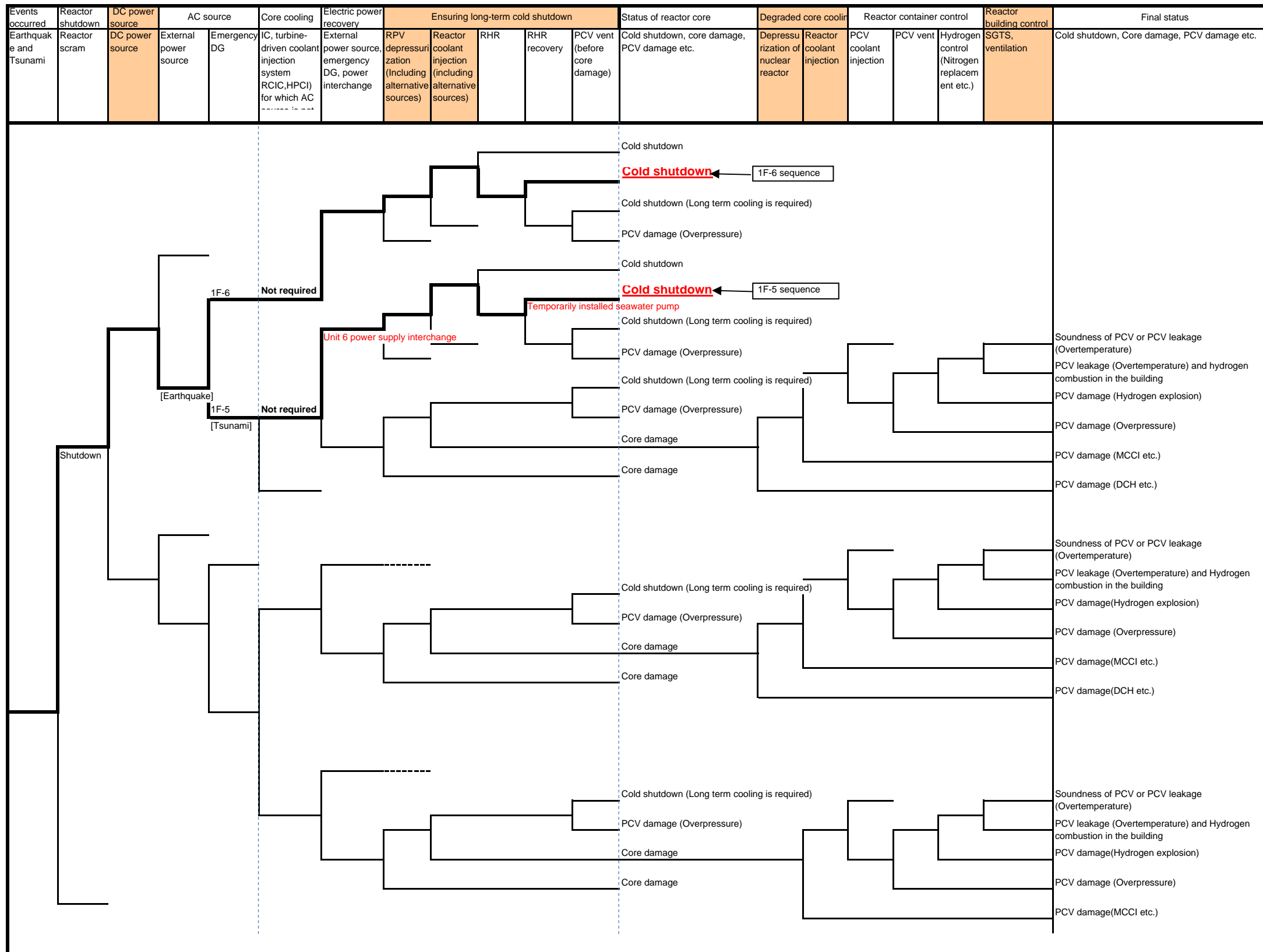

Figure 3.5-1 Event tree of event progress in Fukushima Daiichi Nuclear Reactor Unit 5, 6

## **(1) Unit 5**

Refer to “2.6 Status of Progress of the Accident in Unit 5” in this article for the behavior of the plate when the earthquake occurred.

### **a. Status of “shutdown” function**

When the earthquake occurred, Unit 5 was stopped because it was undergoing a periodic inspection, the pressure of the reactor was increased and maintained to 7.2 MPa for a pressure resistance and leakage inspection, and all control rods were inserted.

### **b. Status of “cooling” function**

All AC power source was lost due to the influence of the tsunami, and the operations of the RHR, the low pressure core spray, and the HPCS became impossible. The pressure of the RPV was reduced a day after the earthquake by opening a valve at the top of the RPV.

On March 13, the pressure and the water level of the reactor were controlled by starting a condensate water transfer pump using the power source that was exchanged from Unit 6, by properly reducing the pressure with the SRV, and at the same time by repeating an operation of supplying water from the CST to the reactor with the condensate water transfer pump.

Then, both the spent fuel pool and the reactor were cooled by building a temporary sea water pump to take sea water and by alternating cooling of the spent fuel pool and the reactor by switching system configurations of the RHR.

### **c. Status of “trapping” function**

A stable value was shown for the stack radiation monitor, and no abnormality was found.

### **d. Status of the spent fuel pool cooling system**

The water level of the spent fuel pool was full and the water temperature of the pool was about 24°C before the earthquake, and it was not a condition of which cooling of the fuel was impeded during an early stage. Therefore, the cooling of the pool was not yet carried out before the tsunami arrived. Because all AC power was lost due to the tsunami, operation of the RHR became impossible. Then, both the spent fuel pool and the reactor were cooled by building a temporary sea water pump to take sea water and by alternating cooling of the spent fuel pool and the reactor by switching system configurations of the RHR.

### **e. Status of “power supply” function**

Because the external power source was lost due to the earthquake, two emergency DGs were automatically started. Although all AC power was lost due to the tsunami, one diesel generator continued to operate in Unit 6 and power that is necessary to accommodate the power source to Unit 5 was supplied.

## **(2) Unit 6**

Refer to “2.7 Status of Progress of the Accident in Unit 6” in this article for the behavior of the plate when the earthquake occurred.

**a. Status of “shutdown” function**

When the earthquake occurred, Unit 6 was stopped because it was undergoing a periodic inspection, and the RPV top head was tightened with a bolt. The reactor was in a status of cold shutdown, and all control rods were inserted.

**b. Status of “cooling” function**

The reactor was in a status of cold shutdown before the earthquake, and it was not a condition of which cooling of the fuel is impeded during the early stage. Therefore, the cooling of the pool was not yet carried out before the tsunami arrived.

The function of two diesel generators was lost due to the influence of the Tsunami, and the operations of the RHR, the low pressure core spray system, and the HPCS became impossible. On the other hand, one diesel generator continued to operate and power that is necessary to maintain the function of supplying water to the reactor was supplied. The pressure and the water level of the reactor were controlled by starting a condensate water transfer pump on March 13, by properly reducing the pressure with the SRV, and at the same time by repeating an operation of supplying water from the CST to the reactor on and after March 14.

Then, both the spent fuel pool and the reactor were cooled by building a temporary sea water pump to take sea water and by alternating cooling of the spent fuel pool and the reactor by switching system configurations of the RHR.

**c. Status of “trapping” function**

A stable value was shown for the stack radiation monitor, and no abnormality was found.

**d. Status of the spent fuel pool cooling system**

The water level of the spent fuel pool was full and the water temperature of the pool was about 25°C before the earthquake, and it was not a condition of which cooling of the fuel was impeded during the early stage. Therefore, the cooling of the pool was not yet carried out before the tsunami arrived. Because two diesel generators were lost due to the tsunami, the operation of the RHR became impossible. Then, both of the spent fuel pool and the reactor were cooled by building a temporary sea water pump to take sea water and by alternating cooling of the spent fuel pool and the reactor by switching system configurations of the RHR.

**e. Status of “power supply” function**

Because the external power source was lost due to the earthquake, three emergency DGs were automatically started. Although the function of two diesel generators was lost due to tsunami, one diesel generator continued to operate and power that is necessary to accommodate the power source to the reactor for cooling and to Unit 5 was supplied.

### **3.6 Comparison of progress of accidents of Fukushima Daiichi Nuclear Power Station with that of other stations**

In the accident at this time, a large amount of radioactive substance was discharged from Fukushima Daiichi Nuclear Power Station (Fukushima Daiichi) into the environment. However, we decided to learn a lesson also by comparing a station that ended up discharging a radioactive substance with a station that didn't discharge even though the tsunami hit. Fukushima Daini Nuclear Power Station, Onagawa Nuclear Power Station (referred to as "Onagawa" below), and Tokai Daini Nuclear Power Station (referred to as "Tokai Daini" below) that were affected by the tsunami were selected as stations that didn't discharge a radioactive substance, and an investigation and comparison of Fukushima Daiichi Units 1 to 3 with these stations were performed.

As shown in Fig. 3.6-1, the transition of the event in Fukushima Daiichi Units 1 to 3 and other stations is branched from the heading of the AC power source (the external power source or the emergency DG), and the power source was secured in all the other stations as a result, which led to prevent the accident from extending.

Hence, it is found that the main cause of the extension of the accident in Fukushima Daiichi is that the external power source and the emergency DG were lost due to the effect of the earthquake and the tsunami and all of the safety components and the facilities to counter severe accidents couldn't function excluding some of the components that don't need a power source.

As shown in Table 3.6-1, the main reason that the power source was secured in other stations is considered to be that their sites were relieved from the infiltration of the tsunami. The tsunami did infiltrate the site of Fukushima Daini, and the external power source, the power source panel, the emergency DG, etc. were damaged. However, the accident was settled by using a power source and facility that were not damaged because the infiltration of the tsunami was limited.

The core cooling and the ultimate heat sink can become a common cause of making decay heat removal impossible and can lead to the extension of the accident. The core cooling by the RCIC and the HPCS was possible in Fukushima Daini, Onagawa, and Tokai Daini, and cooling of the reactor by the core cooling system was sufficiently effective as long as the power source could be secured.

Ultimately, cooling by the RHR was secured and the event was settled in all of the above described stations. In the case of Tokai Daichi, tsunami countermeasures were taken in the sea water pump area for the sea water system pertaining to the ultimate heat sink. When the components in which the countermeasures were already taken operated, a smooth settlement of the event became possible. Hence, the importance of tsunami countermeasures for the sea water system (soaking prevention countermeasures) can be seen.

Details of the investigation of each station are attached as Appendix-1.

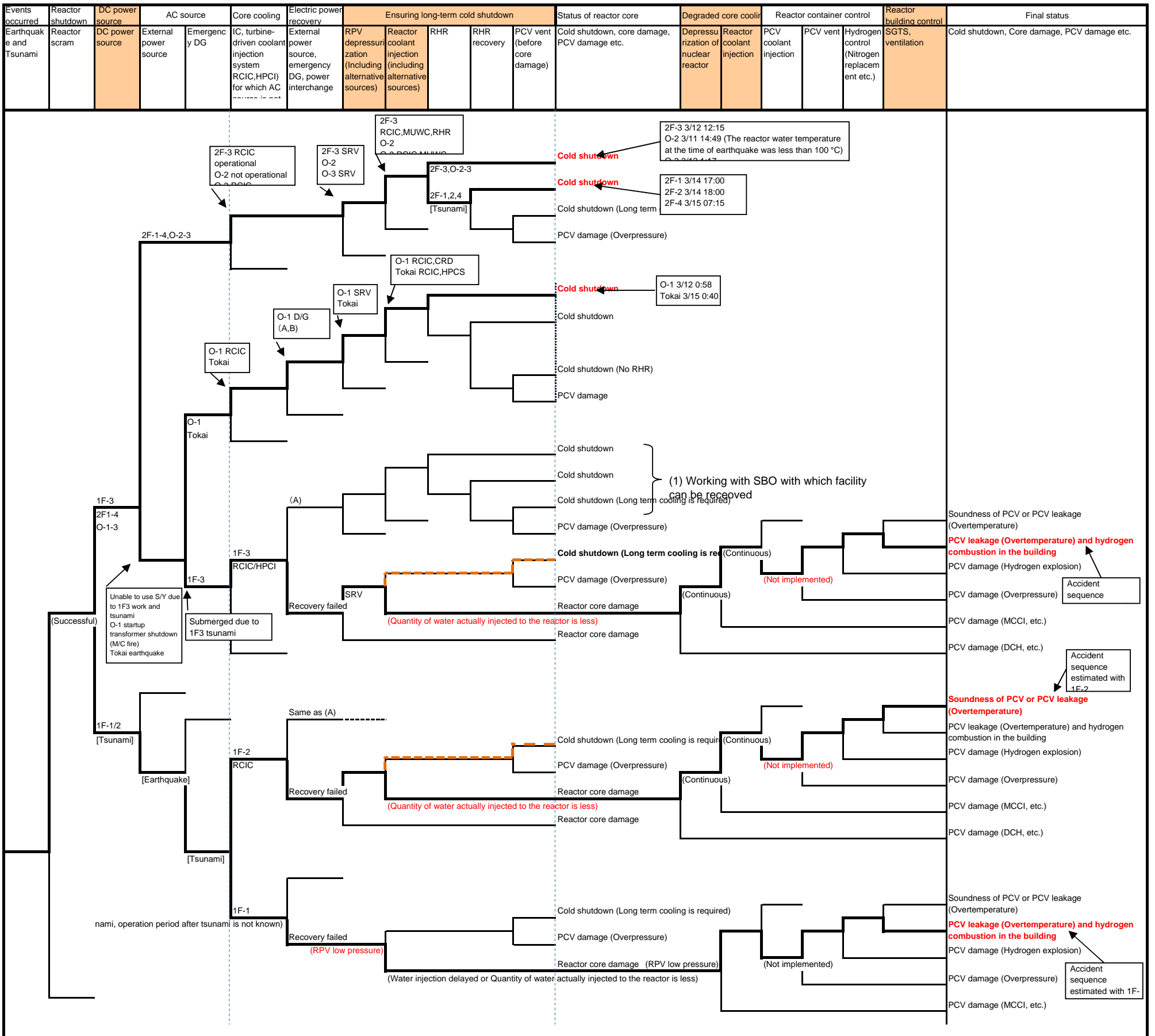

Figure 3.6-1 Event tree of event progress in Fukushima Daiichi Nuclear Plant Units 1 - 3, Fukushima Daini, Onagawa, Tokai Daini

**Table 3.6-1 Comparison of conditions and specifications of plants that were damaged in the tsunami following The Great East Japan Earthquake**

		Fukushima Dai-ichi						Fukushima Dai-ni					
		1	2	3	4	5	6	1	2	3	4		
Condition of plant when earthquake occurred		Operational	Operational	Operational	Suspended	Suspended	Suspended	Operational	Operational	Operational	Operational		
Condition of the plant after tsunami	External power supply	Among 6 lines (1 line under construction), all unusable <sup>*1</sup>						Among 4 lines (1 line under construction), 1 line usable <sup>*1</sup>					
	Emergency DG (main body)	Existing DG (1A, 1B, 2A, 3A, 3B, 4A): Damaged Extension DG (2B, 4B): No damages				No damages		Damaged	No damages				
	Power panel (M/C, P/C, DG)	Emergency	Damaged (except part P/C)				No damages		Damaged (part M/C, P/C usable)	No damages (part P/C unusable)			
		Normal	Damaged (except part P/C)						No damages				
	Emergency cooling system sea water pump (main body)	Damaged						RHRS No damages [Loss of power]	No damages to RHRS(B) only [Loss of power]	RHRS No damages [loss of power to A]	No damages to RHRS(D) only [Loss of power]		
	Emergency cooling system (Including Emergency condenser (IC))	IC (operational time unknown)	RCIC (Operational for approximately 3 days)	RCIC (Operational for approximately 1 day), HPCI (Operational for approximately half a day)	-		(Suspended)		RCIC	RCIC	RCIC	RCIC, HPCS	
	Severe accident countermeasures equipments	Containment vessel vent	○	?	○	-	-	-	(Vent line configuration complete)				
MUWC alternative injection		×	×	×	×	×→○	○	○	○	○	○		
Specifications of each plant	Expected height of tsunami (Society of Construction Engineer)	O.P.+5.7m						O.P.+5.2m					
	Height of tsunami at arrival	Approximately +13m <sup>*2</sup>						Approximately +9m <sup>*2</sup>					
	Site height	O.P.+10m				O.P.+13m		O.P.+12m					
	Principal building surrounding immersion depth [Inundation height]	Approximately 1.5 - 5.5m [O.P. approximately +11.5 - +15.5m <sup>*3</sup> ]				Approximately 1.5m or less [O.P. approximately +13 - +14.5m]		Approximately 2.5m or less (almost zero except surroundings of Unit 1) [O.P. approximately +12 - +14.5m <sup>*4</sup> ]					
	Deployment of power panel (M/C, P/C), emergency DG (building, hierarchy)	Emergency	DG	T/B B1F	T/B B1F Common pool1F	T/B B1F	T/B B1F Common pool 1F	T/B B1F	C/S B1F D/G building 1F	C/S B2F	C/S B2F	C/S B2F	C/S B2F
			Power panel	T/B 1F C/B B1F	T/B B1F T/B 1F Common pool B1F	T/B B1F	T/B B1F T/B 1F Common pool B1F	T/B B1F	C/S B2F C/S B1F C/S 1F DG building B1F	C/S B1F Hx/B 1F	C/S B1F Hx/B 1F	C/S B1F Hx/B 1F	C/S B1F Hx/B 1F
		Normal	Power panel	T/B 1F	T/B B1F T/B 1F 2SA building 1F	T/B B1F C/B B1F	T/B B1F T/B 1F	T/B B1F T/B 2F C/B B1F	T/B B1F	C/B B1F C/B 1F	C/B B1F C/B 1F	C/B B2F C/B 1F	C/B B2F C/B 1F
	Availability of Air-cooling DG (Y/N)	N	Y (DG2B)	N	Y (DG4B)	N	Y (DG6B)	N	N	N	N		
	Diversity in external power supply (diversity in no. of lines, switchyard)	6 lines						4 lines					
	Water-tightening (pump area, building)	Sea water system installed outside the building						Although the sea water system was installed in the building, electrical power systems were damaged (except B system of Unit 3)					

T/B: Turbine building, Common pool: Common pool building, C/B: Control building, C/S: Combination structure (Waste disposal building, Gaseous waste disposal building are combined and stored in 1 building around the conventional reactor building), Hx/B: Heat exchanger building

<sup>\*1</sup>: Damages to transmission tower, switchyard etc are the damages due to earthquake, <sup>\*2</sup>: Height of tsunami in tide station installation position of both the power plants. For instrument damage, the actual height of tsunami in tide station is unknown, <sup>\*3</sup>: O.P. approximately +16 - +17m [immersion depth approximately 6 -7m] locally in the southwest of the said area, <sup>\*4</sup>: O.P. approximately +15 - +16m [immersion depth approximately 3 - 4m] locally from the south of Unit 1 till the seismic isolation significant buildings

**Table 3.6-1 Comparison of conditions and specifications of plants that were damaged in the tsunami following The Great East Japan Earthquake**

		Onagawa			Tokai Dai-ni		
		1	2	3			
Condition of plant when earthquake occurred		Operational	Start-up	Operational	Operational		
Condition of the plant after tsunami	External power supply		Among 5 lines, 1 line usable			Among 3 lines, all unusable* <sup>1</sup>	
	Emergency DG (main body)		No damages* * In Unit 2, as the RCW (B) system and HPCW system were flooded, DG (B) and DG (H) could not be used.			No damages	
	Power panel(M/C,P/C,DG)	Emergency	No damages			No damages	
		Normal	M/C 6-1A Fire	No damages		No damages	
	Emergency cooling system sea water pump (main body)		RHRS, ECWS No damages	RSW (B) system: Damaged RSW (A) system and HPSW system no damages	RSW, HPSW No damages	RHRS No damages [A system Loss of power] DGSW(2C) damaged	
	Emergency cooling system (Including Emergency condenser (IC))		RCIC, HPCI	RCIC, HPCS		RCIC, HPCS	
	Severe accident countermeasure equipments	Containment vessel vent	-	-	-	-	
MUWC alternative injection		-	-	○	-		
Specifications of each plant	Expected height of tsunami (Society of Construction Engineer)		O.P.+13.6m			Altitude + 4.9m	
	Height of tsunami at arrival		O.P.+13.0m			Altitude + 4.8-5.3m	
	Site height		OP+14.8m* * Crustal movements around the power station due to the earthquake has been estimated to be approximately 1m, currently it is 13.8m			T.P.+8.0m* * Value before earthquake	
	Main building surrounding immersion depth[Inundation height]		No immersion			No immersion	
	Deployment of power panel(M/C,P/C), emergency DG (building, hierarchy)	Emergency	DG	C/B B3F	R/B 1F	R/B 1F	C/S B1F
			Power panel	T/B B1F, C/B B2F	R/B B1F	R/B B1F	C/S B2F C/S B1F C/S 1F (direct current power supply panel)
		Normal	Power panel	T/B B1F	C/B B1F	S/B B2F	C/S B2F C/S B1F
	Availability of Air-cooling DG (Y/N)		N			N	
Diversity in external power supply (diversity in no. of lines, switchyard)		5 lines			3 lines		
Water-tightening (pump area, building)		Sea water system installed outside the building			Installed tsunami countermeasure side wall of pump area T.P.+6.1m Affected the under construction sealing work of the wall penetration of one side pump area		

T/B: Turbine building, Common pool: Common pool building, C/B: Control building, C/S: Combination structure (Waste disposal building, Gaseous waste disposal building are combined and stored in 1 building around the conventional reactor building), Hx/B: Heat exchanger building

\*1: Damages to transmission tower, switchyard etc are the damages due to earthquake

### 3.7 Causal analysis

An event tree analysis of the Fukushima Daiichi accident has shown that the major cause for aggravation of the situation was the loss of all safety systems due to the failure of power-supply sources.

According to the same analysis, other nuclear power stations averted a similar deteriorating situation largely due to the securing of power sources.

Nuclear power stations are equipped with emergency DGs and designed to promptly replace external power supplies. At Fukushima, the emergency DGs were submerged. Furthermore, even if the external power sources had been restored, emergency power-supply devices (such as emergency DGs and power-supply vehicles) could not have been connected because the power panels were also submerged as a result of the massive tsunami. This was a major reason for exacerbation of the situation.

In short, the real issue was the lack of preparation for such a state of emergency. Stricter safety measures could have ensured different results. A worst-case scenario and countermeasures for it should have been developed. For example, “if a tsunami reaches station premises, water may come into buildings and important safety equipment including power panels may be submerged/compromised. With this in mind, seal such important systems to prevent water from seeping in or encase them in a watertight compartment. Reinforce facilities and equipment in the event such protection is lost, and furthermore, be prepared to deal with such a situation in case such enhancement is not sufficient.”

The major cause for aggravation of Fukushima Daiichi situation was the loss of power-related facilities/equipment such as external power sources, emergency DGs and power panels, as well as the lack of preparedness for dealing with such an emergency.

While securing power supply could have mitigated the emergency to a certain extent, securing cooling functions would also have been needed. During the disaster, Fukushima also lost component cooling systems as a result of the lack of sea water pump functions. Therefore, stringent emergency measures are needed for power supplies as well as for cooling systems.

We have classified identified issues into the following five categories. Chapter 4 will describe these issues and required preparation/measures:

- Countermeasures against earthquakes/tsunamis (natural hazards)
- Securing of power supply
- Measures against loss of heat sink systems
- Measures against hydrogen leakage
- Preparation for emergencies

Category	Issues/requirements
Countermeasures against earthquakes/tsunamis	<ul style="list-style-type: none"> <li>• Seismic adequacy of external power sources</li> <li>• Appropriate arrangement for switchyards</li> <li>• Appropriate arrangement for sea water systems</li> <li>• Protection of sea water pumps from submergence</li> <li>• Appropriate arrangement for emergency DGs</li> <li>• Air/water tightness of buildings</li> </ul>

Category	Issues/requirements
Securing of power supply	<ul style="list-style-type: none"> <li>• Only one incoming panel to receive external power</li> <li>• Reliability of power sources in case of tsunami</li> <li>• Submergence of power supply systems</li> <li>• Runout of DC power supply</li> <li>• Securing of battery capacity</li> <li>• Obtaining power from external sources (e.g., power-supply vehicles)</li> <li>• Securing of AC power supply</li> <li>• Cable installation for alternate power sources</li> </ul>
Measures against loss of heat sink systems	<ul style="list-style-type: none"> <li>• Submergence of sea water pumps</li> <li>• Ensuring entire facilities/equipment so as it cannot be put out of commission by a single event</li> <li>• Setting up heat sink systems that will not be nullified by tsunamis</li> <li>• IC isolation signal in the event of loss of DC power supply</li> <li>• Securing of equipment to cope with valve drive failure</li> <li>• Establishing emergency procedures and training</li> <li>• Loss of freshwater sources</li> <li>• Earthquake protection and tsunami countermeasures for FP piping</li> <li>• Procurement of fuel for fire-extinguishing vehicles</li> <li>• Enhancement of drive source for pressure-retaining vent line valves</li> <li>• Inoperability of rupture disks at low pressure</li> <li>• Securing of compressed air to maintain opening container ventilation valve</li> </ul>
Measures against hydrogen leakage	<ul style="list-style-type: none"> <li>• Reinforcement of container gasket and penetration area sealing</li> <li>• Leakage from pressure-resistant ventilation line to buildings</li> <li>• Circulation between buildings that share the same exhaust stack</li> <li>• Hydrogen retention in R/Bs</li> <li>• Detection of hydrogen</li> </ul>
Preparation for emergencies	<ul style="list-style-type: none"> <li>• Securing sufficient personnel for radiation management/monitoring</li> <li>• Protection of radiation control facilities from tsunami damage</li> <li>• Obstructions created by earthquakes/tsunamis</li> <li>• Communication methods in the event of loss of AC power</li> <li>• Tools/equipment to support nighttime/indoor operations</li> <li>• Machines/equipment to secure road access</li> <li>• Securing of more than one access route within the premises</li> </ul>

Category	Issues/requirements
	<ul style="list-style-type: none"><li>• Support systems between power companies</li><li>• Deterioration of environment due to hydrogen explosion and rising radiation</li></ul>

**Source:**

- (1) Report of Japanese Government to the IAEA Ministerial Conference on Nuclear Safety (June 2011)
- [http://www.kantei.go.jp/jp/topics/2011/pdf/houkokusyo\\_full.pdf](http://www.kantei.go.jp/jp/topics/2011/pdf/houkokusyo_full.pdf)
  - [http://www.kantei.go.jp/jp/topics/2011/pdf/app\\_full.pdf](http://www.kantei.go.jp/jp/topics/2011/pdf/app_full.pdf)

## **Chapter 4 Lessons Learned and Measures To Take**

As described in Chapter 3, the situation at the Fukushima Daiichi Nuclear Power Station became serious due to the loss of power sources as a result of destruction of most safety equipment by the tsunami, as well as the failure of backup measures (severe accident measures) that were expected to control the situation.

From this accident, we have learned that the following preparations/countermeasures are critical:

- Countermeasures against natural hazards
- Securing of power supply
- Measures against loss of heat sink systems
- Measures against hydrogen leakage
- Preparation for emergencies (training/drills)

### **4.1 Countermeasures against natural hazards**

This document describes the damage caused by the earthquake and subsequent tsunamis and our recommendations on countermeasures.

The size of the earthquake that occurred on March 11, 2011 was mostly within the predicted values for the facility design. The post evaluation conducted by TEPCO utilizing acquired seismic waves reflected that the safety devices/equipment would not have been inoperable. However, the combination of several earthquakes within a close proximity created a massive tsunami. The possibility of this phenomenon had never been considered. The height of possible tsunamis needs to be re-evaluated based on this newly recognized phenomenon.

Power sources for the station were damaged by the tsunami. Calculation based on outdated knowledge did not anticipate that the height of a tsunami would exceed ground level at the station. Therefore, the possible consequences of sea water infiltration were not carefully considered and sufficient countermeasures taken.

While the precise size of natural hazards such as tsunami and typhoons is not foreseeable, we must prepare for hazards that may exceed the calculated design basis. If there is a possibility of a severe power station accident, even through the probability of that possibility is minimal, we must take steps to protect existing properties and bring more facilities/equipment to bear in order to improve endurance and resolve vulnerability issues.

### **4.2 Securing of power supply**

In the event the power supply for a station is cut off, there are external power sources that may be tapped to supply electricity. If for some reason these external power sources are not available, emergency DGs are programmed to start up and provide power to safety equipment. There usually are two groups (or three groups, depending on reactor type) of 100% capacity emergency DGs. Power sources are designed in view of multiple performance and diversity.

At Fukushima Daiichi, the external power supply was cut off due to the earthquake, and subsequently all AC power sources became inoperable because the power panels and emergency DGs were submerged as a result of the tsunami. Although some DC sources managed to escape water-damage, battery life was exceeded before the power supply was reestablished. As a result, most facilities ceased to function and the situation became critical. On the other hand, an air-cooling emergency DG for Fukushima Daiichi, Unit 6, was not affected by the

tsunami and maintained continued to operate. Decay heat at this unit was relatively low because it was under suspension and there was adequate time to cool down. The fact that this unit was able to successfully reach cold shutdown can be used as an example when planning countermeasures in the future.

As for power supply, we need to enhance existing facilities/equipment in preparation for natural hazards and establish reliable backup measures in the event they should fail to function.

Possible appropriate measures include ensuring that the facilities are watertight in order to protect them from possible tsunamis, and using power-supply vehicles to provide electricity in case existing equipment fails to function.

### **4.3 Measures against loss of heat sink systems**

As mentioned earlier, one of the major causes behind the aggravation of the Fukushima situation was the functional failure of emergency DGs due to loss of the power supply. While some of the emergency DGs failed to function as a result of submergence/the submergence of the power panels, lack of cooling water due to damage to sea water pumps caused by the tsunami also contributed to the failure of some DGs.

Since the power failure caused severe equipment damage, the sea water pump failure was not very conspicuous. However, loss of sea water pumps may lead to the simultaneous functional failure of other various equipment (such as cooling water destination pumps and heat exchangers), and result in further aggravation of the situation.

Therefore, protection of sea water pumps from tsunami damage is required and measures to immediately restore their functionality are also important. Reactor cooling system must also be secured in case the sea water pumps become inoperable. In view of the need to cool reactors during power outages, alternate coolant injection by utilizing existing equipment or provisions for the establishment of temporary systems should be planned, and water sources should be secured to provide continuous cooling capability.

### **4.4 Measures against hydrogen leakage**

Explosions allegedly by hydrogen at Fukushima Daiichi, Unit 1, 3 and 4 destroyed the roofs and walls of these R/Bs and brought about obstacles to deal with the situation.

Under such circumstances, the cooling down of the reactors and maintenance of the cooling effort must be the highest priority regardless of whether the core is damaged or not. Accurate data on the reactor core may not be available during a state of emergency at a nuclear power station and the possibility of core damage and hydrogen leakage must always be considered. Hydrogen is a substance that can easily escape. It is necessary to keep it in mind that the hydrogen leak may spread beyond the normal containment area.

A PCV is usually used to contain hydrogen. PCVs also act as recombiners in which nitrogen is added in order to inactivate the hydrogen.

However, in situations where the high temperatures/pressures exceed the design parameters, hydrogen may leak from penetration or the flange gasket sealing of PCV and then accumulate inside of R/Bs. As the containment vessel ventilates, hydrogen then may go enter the pipes connected with exhaust stacks.

Under the presumption that hydrogen is susceptible to leakage, countermeasures should be established to stop the accumulation/leakage, and

provisions for controlled burns should be developed. Power outages also need to be assumed whenever these measures are taken.

#### **4.5 Preparation for emergencies (training/drills)**

The employees and contractors at Fukushima Daiichi had to work under extreme circumstances: a power blackout, loss of meters and gauges, loss of communication ability, high radiation, a highly contaminated environment, scattered rubble and debris, ongoing tsunami warnings, multiple reactor units accidents, as well as having to deal with other emergency operations that included the need to arrange for temporary hoses/cables and radiation monitoring equipment. Few of those workers had ever had such experience and that was one of the reasons that it took an inordinate amount of time to carry out these emergency tasks. On-site personnel were not the only ones who faced difficulties. TEPCO Headquarters' command structure was also plunged into turmoil due to the number of accidents and the rapidly spreading damage.

We must establish provisions for dealing with such situations with restricted conditions.

The seismic isolated building effectively functioned as an emergency command post. This fact is an excellent case example for other power stations. Based on the experience gained from this accident, various facilities/equipment have been added and new emergency manuals have been established. Training and drills for possible stringent conditions must be conducted by using currently available facilities/equipment and manuals in order to be proficient in responding to an emergency. Crisis handling systems, line of command and efficacy of each measure must be evaluated and improved upon, if necessary, during such training.

Examples of emergency measures are as follows:

## **4.6 Countermeasures against earthquakes/tsunamis (example measures)**

### **4.6.1 Assumption of earthquake/tsunami strength**

Although the strength of the earthquake on March 11, 2011 exceeded maximum response acceleration value against reference seismic movement, Ss, all the emergency functions, “stop”, “cool” and “contain” at Fukushima Daiichi were functioning during and right after the quake until the tsunami descended upon the site.

Sea water pumps and emergency DGs became inoperable once the massive tsunami reached the grounds of the station site and after the quake had disrupted the external power supply. Furthermore, all power sources and ultimate heat sinks were lost simultaneously as a result of submergence of the metal clad switchgears, power center and DC power facilities.

Road damage and debris caused by the quake/tsunami interfered with operations to connect external power sources. As a result, the SBO state lasted for hours and coolant injection into reactors was delayed.

### **Findings/lessons learned**

- The combination of multiple hypocenters created a massive earthquake (in magnitude, size of affected area and length of shift). Such interrelated earthquakes had not been anticipated.
- Despite the strength of the quake, the earthquake response spectrum located on the foundation of the R/Bs showed about the same value as the response spectrum for the design basis (earthquake ground motion), Ss. Essential safety facilities/equipment continued functioning.
- Large shift of a fault triggered huge tidal waves. The combination of such waves created a massive tsunami that exceeded predicted the tsunami water level and descended upon the station, causing extensive damage.

### **Measures to take**

Given the above findings, the following measures should be taken:

- The current design basis for earthquake ground motion, Ss probably correspond to future earthquakes. However, possible combination of multiple hypocenters in the neighboring waters should also be considered in order to ensure safety.
- To calculate height of future tsunami waves triggered by earthquake, possible combination of multiple hypocenters should be considered as a wave source at the boundary of ocean-trench plates. The value of distance of possible shift at a hypocenter should also be set to larger value as appropriate.

Measures to deal with obstacles that interfere with emergency operations such as the handling debris are described in “4.5.4 Preparation for emergencies (heavy equipment and rescue efforts), and emergency cooperative system.”

### **4.6.2 Protection of the site from tsunami**

The massive tsunami easily exceeded the elevation of the Fukushima Daiichi site. The reactor cooling system ceased functioning as a result of damage to the sea water systems and the loss of the power supply including emergency power.

Tanks that were flushed away by the wave blocked roads causing further delay in the preparing of injecting coolant by fire trucks.

#### **Findings/lessons learned**

- Station equipment/facilities may submerge depending on their location and sea water may prevent safety equipment from properly functioning.
- Debris/ wreckage brought by tsunami may block emergency traffic from reaching the scene.

#### **Measures to take**

Given the above findings, the following measures should be taken:

- Safety requires that all power-supply facilities be located in an area that will not be affected by tsunamis. Coastal levees (tide barriers) or breakwaters must be installed. Alternatively, protection barriers or multilayered water protection measures need to be taken to ensure the safety of the facilities.
- Barriers that prevent structures from becoming floating wreckage and blocking access of emergency vehicles need to be installed. Heavy equipment needs to be available in order to remove debris/wreckage.

### **4.6.3 Protection of buildings**

Buildings were flooded by water from the tsunami causing safety equipment to become inoperable.

#### **(1) Water tightening of critical facility areas**

Almost the entire area around the main buildings of Fukushima Daiichi were flooded by the tsunami. The water entered the buildings allegedly from ground-level openings such as doorways and equipment hatches, vent openings (louvered doors) and openings connected to under-ground trench ducts (cable/pipe pass-through slots).

Most emergency power panels in Unit 1 through 5 and DC main busbar panels in Unit 1, 2 and 4 were submerged. (There was no inundation in Unit 6.)

Emergency DGs also became inoperable in Unit 1 through 5 due to the submergence of the DGs themselves or their power panels. Air-cooled emergency DGs were installed in Unit 2, 4 and 6, and the ones in Unit 2 and 4 became inoperable due to submergence of power panels. (The water-cooled emergency DG in Unit 6 also became inoperable due to the inoperability of the sea water cooling system stemming from damage as a result of the tsunami.)

The framework of main building including outside walls and columns did not suffer significant damage from tsunami. However, inundation into the buildings from openings caused the loss of power-supply equipment resulting in loss of all DC/AC power sources and ultimate heat sinks.

#### **Findings/lessons learned**

- Insufficient preparation to prevent inundation and inadequate endurance to wave power allowed sea water to enter the main buildings from broken doors on the sea side and from other openings such as louvered doors.
- As a result of the tsunami, sea water overflowed into important facilities/equipment (such as electrical facilities) from entrance doors and other openings including pipe penetration and resulted in those facilities/equipment becoming inoperable.
- Recovery operations were delayed due to accumulated sea water inside

the buildings.

### **Measures to take**

Given the above findings, the following measures should be taken:

- Steps to better protect against inundation including improving sealing capability at penetration and openings (such as doors and vents) must be taken.
- Impact of inundation must be minimized by the water tightening of doors to key safety facilities.
- Portable drain pumps need to be equipped in buildings in order to be able to drain sea water and ensure speedy restoration.
- Doors facing the ocean and that may receive direct impact from a tsunami must be reinforced.

### **(2) Protection of sea water systems against inundation**

At Fukushima Daiichi, sea water systems ceased functioning due to the unanticipated size of the tsunami, but the system at Unit 5 and 6 was reestablished by using substitute pumps. At Fukushima Daini, all sea water systems except the one at Unit 3 ceased functioning, but the system was eventually brought back on line by using replacement motors. At Tokai Daini, all sea water pumps remained operational except one because a floodwall was under construction around the sea water pump area. No stations experienced any blockage or damage of intake channels due to debris/wreckage.

### **Findings/lessons learned**

- Fukushima Daiichi lost all sea water pumps due to the tsunami.
- Specific measures must be taken so as not to lose the operation of all of sea water pumps at the same time.

### **Measures to take**

Given the above findings, the following measures should be taken:

- Protection against inundation including the building of floodwalls around sea water pumps must be initiated.
- Extra motors must be reserved to ensure a speedy recovery.
- Portable sea water pumps should be held in reserve or waterproof pumps should be installed.

## **4.7 Preparation for power supply (example measures)**

### **4.7.1 SBO and loss of DC power sources**

Transmission of the external power supply broke down and external power was lost due as a result of the earthquake. The emergency DGs started up right away as intended and the required power supply for the station was reestablished.

However, due to the inordinate size of the tsunami, power-supply facilities, including emergency DGs that were not capable of withstanding inundation, were subsequently submerged and all AC power sources were lost. Power from DC power-supply facilities that were not submerged ceased later due to the exceeding of battery life. As a result, Fukushima Daiichi lost all power sources.

Traces of the tsunami showed that it reached the area around the switchyard and incoming electricity transformers. The power supply line from neighboring station, which is one of the severe accident response measures, failed because

the closest station also went down.

Fukushima Daini, Unit 1, 2 and 4, also lost their sea water cooling systems. However, core cooling was maintained by RCIC followed by an alternate cooling operation. Meanwhile, the sea water system was reestablished and the radiation cores went into a cold shutdown state. Thus, the safety of power station can be ensured through the use of emergency equipment/facilities provided the power supply is secured.

In order to recover the power supply, Fukushima Daiichi tried to bring power-supply cars and connect them to the station facilities. Access to the station was hindered due to congestion of the surrounding roads and road damage as a result of the earthquake. Although batteries and manpower to lay heavy cables was brought to Fukushima to assist with the recovery effort, submergence of power panels resulted in an extended power blackout period.

#### **Findings/lessons learned**

- Emergency DGs were installed to cover the loss of external power sources. However, emergency DGs also became inoperable due to the tsunami. Further backup systems are needed.
- In order to ensure the reliability of incoming electricity transformers and switchyards, the external power supply for them needs to be protected from tsunamis.
- Emergency DGs and related facilities were submerged and became inoperable as a result of the tsunami. These DGs need to be protected against such damage.
- Some of DC power-supply facilities were submerged and lost functionality. Other DC power-supply facilities that were not affected by the tsunami ran out power and became inoperable because they could not recharge. Such long-term needs have to be considered.
- Severe accident response facilities (power panels to bring electricity from other stations) were submerged by the tsunami. These facilities need to be protected from inundation.
- As an emergency response, power-supply cars were sent to Fukushima Daiichi, but were delayed because of the adverse conditions brought on by the earthquake/tsunami. The mobility of power-supply cars is very useful but the way to provide speedy access under adverse circumstance must also be developed.

#### **Measures to take**

Given the above findings, the following measures should be taken:

- Backup power supply in the event emergency DGs become inoperable
  - Reserve earthquake/tsunami-proof power-supply cars or large-capacity batteries (gas turbines or diesel generators) as backup power sources and the establishment of emergency procedures (e.g. steps to obtain fuel such as light oil and how to connect power sources).
- Protection of external power sources against inundation
  - Review location/arrangement of incoming electricity transformers and switchyards, and make them watertight as needed.
- Protection of emergency DGs and related facilities against tsunamis
  - Review location/arrangement of emergency DGs, power-supply facilities (high and low voltage) and cooling systems for emergency DGs, and secure in watertight structures as needed.
- Protection of DC power-supply facilities against inundation

- Review location/arrangement of DC power-supply facilities, and protect against possible water damage as needed.
- Establish DC power-supply (battery) charging routes from backup power sources.
- Protection of inter-building power-supply facilities (severe accident measures) against inundation
  - Review protection of inter-building power-supply facilities (severe accident measures) against inundation, and improve reliability as needed.

In order to improve the seismic capacity of external power sources, all power companies have been directed by the government to review the seismic adequacy of their transmission wires and improve the reliability of the facilities at locations where landslides may occur. Power companies are also to address the reliability and performance of multiple power systems.

Expansion of battery capacity is a logical strategy, but feasibility is questionable due to required space for such a system and its limited effectiveness. Therefore, in order to secure DC power supply, the first step will be to secure power sources to feed the DC power supply. The second step will be to establish methods to charge batteries as soon as the power source has been lost.

Factors that could interfere with power recovery operations are common to other operations. These factors and approaches are described in “4.10 Preparation for emergency situation.”

## **4.8 Examples of measures addressing the heat sink loss**

### **4.8.1 Water Injection to the reactors**

In this accident, the electric-driven water injection system of ECCS could not be activated due to loss of power supply while the steam-driven water injection system could not continue to operate due to loss of the control DC power supply batteries after a certain period of time or for some unknown reason.

In this case, the alternative low-pressure cooling water injection system required some time before starting cooling water injection because it needed to first depressurize the reactors which lost the driving power supply and the driving air pressure of SRV (ADS function, relief valve function). In addition, MUMC, an alternative water injection system, could not operate because the pump was inundated and the FP diesel fire pump failed. Furthermore, the alternative high-pressure injection facilities (CRD, SLC) were in a state that could not be started due to the complete loss of power supply.

As stated above, the water (fresh water) injection to reactors could not be implemented using the existing injection facilities, and eventually fire engines were used for emergency injection of seawater.

In addition, as for water injection facilities, the actual situation of damages was unknown because they could not function due to loss of power supply, except some of the equipment was known to be damaged by seawater flooded into the building.

### **Findings/lessons learned**

- It was unsuccessful in dealing with the situation that all ECCSs lost their functions due to complete loss of power supply for a long time caused by the earthquake and tsunami, and that the facilities for preventing severe

accidents could not be used. Therefore, it is necessary to examine the measures to ensure long-term water injection (including securing water sources) even if tsunami and earthquake hit.

- In the event that the high-pressure injection system loses its function, the alternative low-pressure injection should perform to depressurize the reactor. However, it is difficult to reduce the pressure due to loss of the source which drives the valve for reactor depressurization. It would take some time before the alternative low-pressure injection system can be used. Therefore, it is necessary to examine the measures to cope with loss of driving source of facilities required for reactor depressurization.
- For the body of the water injection facility, it is also necessary to have measures to deal with seawater flood into the building in a tsunami.

### **Measures to take**

In light of those described above, the following measures should be considered to cope with, for example, the events of BWR.

- To ensure the water injection function to achieve secure water injection to reactors in the event of loss of existing driving sources for a long period of time.
  - To improve the power supply reliability for the existing injection system by deploying a backup power unit or large-capacity power supply
  - To secure alternative means of injection to reactors using portable power pumps and hoses that do not depend on the existing power supply
  - To prepare backup power supply and reserved air cylinders necessary for driving to ensure reliable depressurization of reactors through SRV
  - To secure water source (including seawater as the last resort)
- Among the severe accident prevention facilities, there should be anti-inundation measures by establishing the seawall and watertight doors to the extent expected as the last resort in combination with other alternative means.
- To establish anti-inundation measures by ensuring the watertightness of compartments of safety equipment, such as emergency cooling systems for reactor cores.

In PWR, there should be cooling means of the secondary system required when a station blackout occurs. In these means, water will be supplied to the steam generators through the turbine-driven auxiliary water feed pumps with steam as the driving source; and a steam generator is available for discharging the steam through the main steam relief valve. This is equivalent to secure the function of water injection to reactors in the BWR; therefore, it is important to ensure the means of water supply to steam generator and steam discharge means. In order to achieve continuous heat removal for a long time, the following measures are suggested.

- Improve the power supply reliability for the existing water injection system by deploying a backup power unit or large-capacity power supply
- Secure alternative means of water injection to steam generators using portable power pumps and hoses that do not depend on the existing power supply
- Secure more reliable measures to cool the reactors with the steam generators through the main steam relief valve (including reserved air cylinders)

- Secure water source (including seawater as the last resort)

As stated in the report, “the fire hydrant erupted water, but the filtered water could not be used as the water source”. At this investigation meeting, there was an argument whether it is necessary to improve the reliability of fire-fighting water system. However, Tokyo Electric Power Co., Inc. gave the explanation, “it was difficult to respond to the accident when the FP was damaged by the earthquake”. It is unknown yet whether it is a fact; therefore, the need to examine FP will be decided after the investigation results of Tokyo Electric Power Co., Inc. become available.

#### **4.8.2 Loss of seawater cooling**

As the tsunami was stronger than expected in design, the seawater pump motor and ancillary equipment were damaged and could not operate. The heat removal route “reactor → residual heat removal system → reactor building closed cooling water system → reactor building closed cooling sea water system → seawater” for final heat relief (final heat sink) loses its function, so the heat generated by reactor could not be removed.

In addition, due to the effects other than loss of function of the seawater pump, the ancillary equipment cooling water pump and heat exchanger required for cooling by seawater pumps could not be used; therefore, ECCS and ancillary reactor equipment could not operate even without the power loss.

#### **Findings/lessons learned**

- It is necessary to examine the measures for inundation caused by tsunami because the seawater pumps will no longer be used in a tsunami stronger than expected. (Refer to the section of Tsunami for measures)
- It is necessary to examine the means to recover inundated seawater pumps.
- It is necessary to examine a way to secure the heat removal route in the event that the seawater pumps could not be recovered early.

#### **Measures to take**

In light of those described above, the following measures are suggested.

- Alternatives to sea water pumps
  - Deploy redundant sea water pump motors and develop a replacement procedure after loss of functionality
  - Ensure the power supply which can back up the minimum functions required for sea water pumps
- Have measures for early recovery of sea water pumps
  - Have the cleaning and drying materials available for sea water pump motors
- Ensure an alternative heat removal route
  - Disperse the heat to atmosphere through the containment vent (see the following section)

In addition to the need to take the same measures as above for PWR, there should be an alternative heat removal route “reactor → steam generator → atmosphere” using the secondary system with steam generator in the event that the heat removal route “reactor → residual heat removal system → reactor building closed cooling water system → reactor building closed cooling sea water system → seawater” as final heat sink loses its function.

### 4.8.3 Containment vent

In this accident, the route for heat removal to the final heat sink (sea) failed to function due to loss of sea water cooling; therefore, the heat from reactor was handled according to the procedure using the route “reactor → containment → atmosphere (vent)”.

To allow a rapid depressurization by opening the SRV, it was necessary to lower the containment pressure through the vent before discharge of steam.

Furthermore, when the containment pressure rose, the venting and depressurization were performed in order to ensure the integrity of containment.

In this case, it needed some time before starting the vent because of the following reasons.

- The containment pressure could not be properly understood because of loss of power supply to the metering instruments.
- The remote control was disabled due to loss of power supply to the vent valve and the cylinder pressure. Although alternative manual operation was planned, some time was needed to examine and establish the ways for implementation.
- In addition, due to the increase in building radioactive dose and surrounding room temperature, it was extremely difficult to access the vent valve area.
- The evacuation of the surrounding residents was finally confirmed.

#### Findings/lessons learned

- The temporary rechargeable batteries that could be used for metering instruments, and temporary power supply and air cylinder for driving the vent valves were not prepared in advance for the event when the station blackout continued for a long period of time; the radioactive dose was very high around the vent valve area when the reactor core was damaged, and some time was needed for the vent operation. Therefore, it is necessary to examine how to improve the reliability of vent operation in the event a station blackout continues for a long time.
- It is necessary to remove the radioactive substances other than rare gas caused by the scrubbing effects of pool water of S/C while strengthening the prevention measures for over-heating damage in order to prevent damages to containment while performing the vent.

#### Measures to take

In light of those described above, the following measures are suggested in case of BWR.

- Improve the reliability of vent operation during a complete loss of power supply
  - Deploy temporary power supply to feed the monitoring instruments required to determine the vent preparation and vent implementation
  - Deploy a backup power supply and driving source for vent operation
- Optimize the operating conditions of the vent
  - Conduct future examinations for optimization of the time to start the vent and perform a review as needed.
- Reinforce the alternative containment spray after damages of the reactor core

In addition, in the PWR, there should be a secondary cooling system with steam generator even if the heat removal to the final heat sink fails due to loss

of sea water cooling. This system should be able to continue to remove the heat generated by the reactor. Therefore, for PWR, it is not necessary to discharge the energy in the containment through the vent.

The design of rupture disk has been established, and will include a function to prevent discharge into environment of the containment atmosphere caused by malfunction of valves, and the operation pressure will be set higher than the designed pressure in consideration of the malfunction. If the valve of the vent system can be reliably opened during the pressure rise within the containment, it will achieve its original function of lowering the pressure; therefore, it is believed not necessary to make a change in the design of the rupture disk. However, the measures to lower the set value for operation of rupture disk, or to remove the rupture disk, will have a wider choice in response to accidents as these measures might depressurize the containment early; and whether these measures should be adopted will be determined based on judgment of electric power, considering that there would normally be a small amount of emission of radioactive materials associated with malfunctions.

## **4.9 Hydrogen measures**

In this accident, the hydrogen leaked and was deposited in the reactor building caused by the damage to the reactor core. As a result, the hydrogen-induced explosions occurred in the No. 1 reactor building at 03:36 PM on March 12, and in the No. 3 reactor building at 11:01 AM on March 14.

Due to these explosions, it was difficult to lay power cables and connect the hoses.

Also, an explosion, possibly caused by hydrogen, occurred in the No. 4 reactor building at around 6:00 AM on March 15.

### **Findings/lessons learned**

- As a result of the continued leakage and deposit of hydrogen caused by damage to the reactor cores, the hydrogen-induced explosions occurred in the reactor buildings. It is necessary to consider measures to prevent such a situation.
- In the case of containment vent using the reinforced pressure-enduring vent line, it is necessary to examine the measures to prevent the roundabout of hydrogen from SGTS exhaust pipe, or to prevent the roundabout of hydrogen through the junction of the exhaust pipes shared with other units.
- If temperature rises in the containment and pressure exceeds the design value, the hydrogen from containment penetration and gaskets will leak into the reactor building, which may lead to a hydrogen explosion.

### **Measures to take**

In light of those described above, the following measures are suggested.

- In order to prevent the hydrogen-induced explosion, it is necessary to examine measures to prevent or reduce emission of hydrogen which will be deposited in the reactor building.
- In this accident, it is necessary to examine the route of hydrogen leaked into the reactor building, and to examine the need to set gas detectors to appropriately monitor the deposit of hydrogen in the reactor building if needed.
- If branch pipes are installed in the containment vent line, it is necessary to examine the measures to prevent the roundabout of hydrogen from such exhaust pipes.

- If an exhaust pipe is shared, it is necessary to examine the measures to prevent the roundabout of hydrogen to other units, and ensure independence in terms of engineering.
- It is necessary to have trainings and procedures designed to cope with leaks and deposit of hydrogen.

As for the containment penetration and seals, it is unrealistic to demand proper sealing under a condition exceeding the designed, and measures should be proposed to avoid such a condition. Considering that hydrogen is easy to leak if the reactor core is damaged, it is necessary to take corresponding measures to cope with the hydrogen leaks that may occur.

## **4.10 Emergency preparedness (Especially training)**

### **4.10.1 Training**

Because of severe work environment of the incident response site in this accident where there were hardly any lightings or communication means, and high-dose of radiation with scattered wreckage of building etc., it was very difficult to perform fieldwork such as cable laying from power-supply car and join up, laying alternative injection hose and so forth. Usually the fieldwork needs to take a lot of time and trouble, but we tackled it within a relatively short time through workers' effort. The fieldwork required this time has not been assumed in the countermeasures training for severe incidents so far.

And this accident is a multi-unit and coincident accident that is not presumed in the conventional training, therefore prompt decision-making and response was required with a limited number of staffs on a moment-to-moment basis.

#### **Findings/lessons learned**

- The countermeasures training for severe incidents should include field operation trainings considering the fieldwork under the severe conditions based on real actions, and train on a routine basis so as to take systematical actions in the event of an accident.
- Personnels should get training for various situations on a routine basis in order to take actions in line with time in the event, and are encouraged to understand how the incident response activities affect the course of events.

#### **Measures to take**

Based on the above results, some examples of the countermeasures are shown below.

- Assemble knowledge/proficiency
  - Assemble the knowledge and proficiency requested for each personnel during a severe accident, and provide each personnel with a data-type education and proficiency training in an appropriate manner.
- Field trainings based on real actions
  - Provide personnels with the field trainings for the fieldwork presumably required as countermeasures for severe incidents so as to take the personnels' proficiency in procedures and methods to a higher level.
  - Simulate the fieldwork during nighttime or without communication means, and the fieldwork with full range of protective gears such as a protection clothing and a full-face mask etc. Also consider an impact of obstacles on approaching the field.
- Training based on proceeding with time in the event

- Provide a training having effectiveness with a focus on reliable cooperation and decision under the the same condition as real such as blind training and real-time training etc. in addition to a training based on a scenario.
- Confirm time required for such as approaching the field, wearing the protective gears, and performing fieldwork etc., and then ensure how his/her activities affect the course of events.
- Make use of simulator etc. to enable each personnel to take actions in line with time in the event.

The trainings mentioned above are preferably provided on a regular basis to remind the lessons learned and to maintain/improve the proficiency continuously.

#### **4.10.2 Air conditioning and shield at Central control room**

In this accident, operators couldn't enter MCR or couldn't stay at MCR for a long time because of high radiation dose.

And MCR ventilation system having a charcoal air filter for iodine removal didn't work due to loss of electric power for a long time, therefore it is necessary to wear a full-face mask even in MCR.

These conditions made MCR habitability lower, which was an obstacle to the incident response activities.

#### **Findings/lessons learned**

- Loss of electric power for a long time disabled the MCR ventilation system. In response to this situation, it is required to consider a countermeasure.
- Due to high radiation dose, operators couldn't enter MCR or couldn't stay at MCR for a long time. In response to this situation, it is required to consider a countermeasure.

#### **Measures to take**

Based on the above results, some examples of the countermeasures are shown below.

- A countermeasure to ensure MCR habitability for a long time
  - Ensure power supply to facilitate the MCR ventilation system during emergencies. And therefore put the operation procedure for it in place.
  - Examine the reason why high radiation dose is increased so as to strengthen countermeasures of the radiation protection.

#### **4.10.3 Measurement during accidents**

In this accident, instrument power supply was lost, because DC power supply unit was loss in function in addition to Station blackout for a long time. Therefore, important parameters such as Reactor water level, pressure, and temperature etc. were not measured or records for these parameters were lost, status of a reactor like the injection status was not determined. To restore the instruments, it was required to connect batteries collected from vehicles to the MCR instrument board as temporary power supply.

And from the viewpoint of instrument data reliability, water level of reactor varied from instrument to instrument. According to comparative result of a water level instrumentation installed temporarily to confirm the reliability of instrumentations, actual water level of reactor might be less than the measurement limit of the water level instrumentation in the fuel zone. Therefore,

trend monitoring for reference-plane water level of the water level instrumentation indicated that the reference-plane water level might be lowered continuously by evaporation due to the effect of high temperature in the containment vessel.

With the progress of the accident, unexpected measurement were requested such as water level measurement due to evaporation of pool water at the spent fuel pool, hydrogen-concentration measurement to determine hydrogen leakage and accumulation from the containment vessel at the reactor building and so forth. In fact, there was no means of measurement, so it became difficult to do incident response. Moreover, the building exposed to high radiation prevented staffs from approaching to the instrumentations so that restoring the measurement system became difficult.

### **Findings/lessons learned**

- (Dependable source of power) Losing MCR monitoring function due to loss of electric power for a long time was beyond the scope of assumption. In response to this situation, it is required to be considered.
- (Enlargement of measurement specification) Because Reactor water level was less than the measurement limit of the instrumentation during a severe accident, it is required to consider the outbreak of a severe accident in terms of the measurement system of important parameters that are necessary to understand the plant status.
- (Addition to measurement parameters) There was no means of handling unexpected measurement requests which was not expected in conventionally assumed event occurrence, such as hydrogen-concentration in the reactor building. In response to this situation, it is required to be considered.
- (Ensuring measurement reliability) There was no means of confirming the reliability of the measurement system (measurement data) regarding the important parameters such as Reactor water level during a severe accident. In response to this situation, it is required to be considered.

### **Measures to take**

Based on the above results, some examples of the countermeasures are shown below.

- (Considering dependable source of power) Consideration for restoring instrumentation early in case of loss of electric power for a long time.
  - Prepare temporary storage battery and connection cable near MCR as a backup of power supply.
  - Reconsider the instrumentation power supply such as utilizing power-saving technology or uninterruptible power supply if necessary.
- (Considering enlargement of measurement specification) Consideration of the means to measure important parameters such as Reactor water level to understand the plant status during a severe accident.
  - Consider development of the measurement system having an enlarged measurement limit of Reactor water level, and means to understand the reactor status by measuring the containment vessel even when reactor instrumentation is lost in view of the outbreak of a severe accident.
- (Considering addition to measurement parameters) Consideration of selecting parameters that are newly requested to measure in this accident, and measurement system for them.
  - Establish a parameter measurement system such as hydrogen-concentration in the reactor building.

- (Considering securement of measurement reliability) Consideration of a way to ensure reliability of the measurement system (measurement data) regarding the important parameters during a severe accident.
  - Develop a measurement system that strengthens environment resistance and a variety of measurement means in view of the outbreak of a severe accident.

#### **4.10.4 Emergency Operation Facility**

Emergency Operation Facility is a facility to give countermeasure instructions during an accident and placed within Examination Guide for Safety Design for Nuclear Power Facilities. However, in this accident the available communication method between Emergency Operation Facility and MCR were only hot-line and land line after Station blackout. Communication environment became worse so that the communication between Emergency Operation Facility and the field was hardly established, which impacted on discussion on countermeasures and posed a problem for giving instructions. And personnel went to the administration building that was a restricted area to get valve drawings while aftershock occurrence so as to study the procedure of vent operation for the containment vessel after Station blackout. The storage place of valve drawings should be reconsidered when discussing stored judgment material in Emergency Operation Facility.

From the viewpoint of radiation control in Emergency Operation Facility, since originally any buffering area was not specified to put on/off radiation protection clothing in the earthquake-proof principal building where Emergency Operation Facility was located, the concentration of radioactive materials in the air of building was beyond the limits by law to the day of April 3rd, so that it didn't protect personnel from the risk of internal dose even in the building and it didn't provide enough space for relaxation for staffs who have been working over a long time.

However, the earthquake-proof principal building could withstand the earthquake and Tsunami with independent emergency electric power supply unit and air conditioning system. Though it had problems as mentioned above, it is noticeable that it functioned as a base for incident response activities.

#### **Findings/lessons learned**

- Emergency Operation Facility is a facility to give countermeasure instructions during an accident. It inevitably ensures the communication means to MCR or the field and enables to get plant parameters required for determining countermeasures even under the severe conditions such as Station blackout. Also judgment materials for emergency countermeasures should be prepared at Emergency Operation Facility and personnel should be capable to get them easily if required.
- Emergency Operation Facility is a facility where personnel stay and use when an emergency arises including radioactive release. It needs adequate radiation protection including preventing the internal retention of radiation and considering the external environment when used.

#### **Measures to take**

Based on the above results, some examples of the countermeasures are shown below.

- Emergency Operation Facility is expected to use under the severe natural phenomenon such as an earthquake, tsunami etc., and under the severe

conditions such as Station blackout for a long time, releasing large amount of radioactive material into the environment etc. so that it should be prepared to provide its functionality considering above mentioned situations. Especially consider the following points.

- Building designed and located to withstand an earthquake and tsunami
- Plant capable of using in case of loss of external power supply for a long time and ensuring independent emergency electric power supply
- Collecting the plant parameters required for the countermeasure instructions and ensuring the communication means to MCR and the field
- Radiation protection countermeasures considering large volume of radioactive material release
- Ensuring habitability for long-stay personnels
- Ensuring emergency material for severe environment
- Scrutinizing and ensuring judgment material required for emergency countermeasures

#### **4.10.5 Radiation control/working control**

In this accident, APDs which were used for personal exposure control, submerged in water and part of them became unusable, due to the effects of tsunami. Therefore, number of APDs was not sufficient for all workers. Only some of workers could use APD. And the exposure control system didn't work due to loss of power, so we had to manually record the irradiated dose. Charcoal filter masks which used as iodine adsorbent were also in short, as a result, risk of internal exposure increased. Holding-counter type WBC for measuring internal exposure became unavailable partly because background of radioactive materials on site increased. Measurement using mobile type WBC and measurement in other power station was performed, but it was not enough. It caused confusion because of shortage of all sort of radiation measuring instruments and radiation protection clothing, and also loss of related function.

In the midst of the confusion, exposed persons beyond dose limit were found. It confirmed that multiple staffs involved in emergency works exposed beyond the dose limit 250mSv. And two female staffs who have stayed in the earthquake-proof principal building exposed beyond the dose limit 5mSv per 3 months in total of external exposure and internal exposure. And 3 workers from the contracted company exposed beyond 170mSv ignoring alarmed APD. Especially two of them, wearing low quarter shoes, got their feet wet in radiated water. Since possible beta ray burns were suspected on the basis of radioactive materials attachment, they were taken to a hospital and then to National Institute of Radiological Sciences (NIRS).

In the earthquake-proof principal building, since any buffering area was not specified to put on/off radiation protection clothing, the concentration of radioactive materials in the air of building was beyond the limits by law to the day of April 3rd.

In this accident, because of the vent operation for the containment vessel, radioactive material release to environment due to hydrogen explosion, and scattered wreckage with high-dose of radiation, radiation control service including measurement of environment increased abruptly so that it was very difficult to handle the radiation control service.

## **Findings/lessons learned**

- Due to tsunami and loss of electric power for a long time, it is beyond the scope of assumption that personal dosimeters like APD became heavily unavailable, that radiation protection clothing like mask run short due to rapid progress of the accident, and that WBC became unavailable due to high radiation dose.
- Because radioactive material possibly releases to environment such as the vent operation for the containment vessel during an accident, internal exposure by iodine might become beyond expectation if there is no radiation protection clothing like mask. A base for incident response activities also might have radiation pollution, and as progress of an accident, some of the workplace might increase dose rate or be polluted locally, radiation control should manage both external exposure and internal exposure depending on the situation. And working control should assume it previously.
- During an accident, radiation control service might increase abruptly so it should reinforce the system for acting more quickly.
- Since the doctor who stayed in the earthquake-proof principal building had knowledge of emergency exposure medical treatment, he examined two workers who possibly had beta ray burns and swiftly took them to National Institute of Radiological Sciences. It is an anecdotal experience and we should continuously promote understanding associated with emergency exposure medical treatment.

## **Measures to take**

Based on the above results, some examples of the countermeasures are shown below.

- Prepare materials and equipment such as radiation measuring instruments and radiation protection clothing so as to do adequate radiation control. Following measures are listed for example.
  - Ensure diversification of electric power sources like battery-operated for the radiation measuring instruments and enough electric power sources to use for a long time. Place required number of batteries in the place unaffected by tsunami. And make a plan arranging to interchange required radiation measuring instruments beforehand.
  - Ensure mobile WBC such as WBC on-vehicle, or arrange to use WBC of other facilities.
  - Ensure required number of the radiation protection clothing considering rapid progress of an accident.
- Make Emergency Operation Facility which becomes a base for incident response activities during an accident to be available on the assumption that radioactive material exists in the environment. Let all staffs know the latest information regarding dose rate and pollution in the workplace with the progress of an accident, and open their eyes to the importance of exposure dose reduction.
- Reinforce the system in terms of staffs for acting more quickly to handle the radiation control service which might increase abruptly. For example, arrange a support system that includes radiation management staffs from other sites and staffs who count up the radiation dose without the knowledge of radiation control so that radiation management staffs focus on more important operations.
- Prepare to arrange an emergency exposure medical treatment team in case

of an accident.

#### **4.10.6 Organization/command or order**

Originally director of a plant can decide to do the vent operation for the containment vessel as written in the internal manual. But in this accident, we needed to ask government authorization and to negotiate with local government, when the vent operation became inevitable. External adjustment took time because, for example, it needed to wait until evacuation completed.

And when doing sea water injection at Unit 1, it was proceeded with based on a confirmation and agreement of company president. After that, as a result of discussion between head office and the power plant, the sea water injection was decided to temporarily stop, but it was continued based on a judgment by the director of the power plant. There was a confusion of chain of command or order.

#### **Findings/lessons learned**

- Regarding emergency measures, in the confusion during emergencies it needs an adjustment with associated organizations, therefore, there is a possibility of delay or confusion in a decision of execution.

#### **Measures to take**

Based on the above results, some examples of the countermeasures are shown below.

- Clearly articulate a timing of judgment for the emergency measures that affect badly convergence of an accident, and proceed with external adjustment for them at an early date preparing to do a prompt operation.

#### **4.10.7 Communication**

In this incident response activities, due to water exposure by tsunami and Station blackout for a long time, internal PHS or paging device etc. which was ordinary communication means among the fields, countermeasures headquarter, and MCR, was hardly used.

Because field worker put on full range of protective gears such as protection clothing and a full-face mask etc., they had to work under a severe environment and without communication one another. Therefore, it was very difficult to do the incident response activities because it took time to confirm the field status and to provide direction of a fieldwork.

On the other hand, regarding communication between Power station and outward, in fact the leased line network to internal and external organization was available in this accident, but there is always a risk to be disrupted like internal network in Power station due to an earthquake or tsunami etc.

#### **Findings/lessons learned**

- The communication means within Power station and to outside should be built/maintained by means which is free of the influence of an earthquake or tsunami, and which is capable of using power source even when Station blackout for a long time.
- One communication means between field workers and another communication means among field worker, Countermeasures headquarter and MCR should be prepared considering use with full range of protection gears and under a severe environment during an accident.

#### **Measures to take**

Based on the above results, some examples of the countermeasures are shown below.

- Countermeasures for communication means within Power station and to outside which is free of the influence of an earthquake or tsunami, and which is capable of using power source even when Station blackout for a long time.
  - Prepare backup power such as battery which is free of the influence of an earthquake or tsunami, and which is independent from the reactor facility.
  - Design facilities used on an emergency basis such as servers, communication equipment like switch, and cable communication line or wireless staging base so that they can't just be disrupted by natural disaster such as an earthquake and tsunami.
  - Deploy multiple communication devices such as leased line, satellite phone, and wireless line, and clarify the way of their operation.
- Countermeasures for facilitating communication between field workers, or among worker, MCS and Emergency Operation Facility.
  - Deploy required number of communication devices including the field.
  - Clarify the way of operation for the deployed communication devices and improve worker's proficiency through training at the same time.

#### **4.10.8 Environmental monitoring**

According to government's "Basic disaster prevention plan", in terms of environmental monitoring at the time of nuclear disaster, business operator takes charge of border line and inside of the site boundary, and mainly local government takes charge of outside of the site boundary.

In this nuclear disaster, regarding environmental monitoring for inside of the site boundary and border line which business operator takes charge of, measurement at MP within the site boundary and on border line became unavailable due to loss of external power supply caused by tsunami. Therefore, until the external power supply was restored, the environmental monitoring was continued by use of monitoring vehicle, temporary MP and survey meter etc. And the measurement results were released on the Internet as applicable, though it was limited due to manual creation.

In case of local government's environmental monitoring, environment monitoring equipments and facilities required were not available due to the effect of power outage, communication line disconnected, and local government building swept away by tsunami. And also, the environmental monitoring activities had major obstacle, because persons in local government had to focus on responses to the earthquake and tsunami occurred in a wide area, and because the onsite countermeasures headquarter had to move from the offsite center to Fukushima prefectural government. Moreover, related government offices should help local government to execute and support monitoring based on local government's request, but they were engaged in other earthquake responses such as a lot of missing persons' investigation that covered a wide range, so it was difficult to build the environmental monitoring system just after disaster of the earthquake.

On the other hand, business operators except Tokyo Electric Power Co., Inc. dispatched personnels based on Atomic energy cooperation agreement and supported the environmental monitoring outside the site boundary executed by local government utilizing a monitoring vehicle.

As mentioned above, there was a lot of problems such as monitoring facilities or shortage of personnels etc., but monitoring activities have been done as much as possible. However, some of mass media criticized the delay in releasing monitoring data, and low reliability of offshore monitoring data, and doubted some of monitoring-vehicle measurement data per 2 minutes by Tokyo Electric Power Co., Inc. was not released by reason of complementary data.

#### **Findings/lessons learned**

Since an entity taking charge for the environmental monitoring is different depending on inside or outside of the site boundary, we only describe the monitoring executed by business operator.

- Due to the effect of power outage by tsunami, the permanent monitoring facility of business operator became unavailable, so alternative means had to be used.
- Although accepting personnels based on Atomic energy cooperation agreement and working with environmental monitoring activities conducted by local government to do monitoring activities continuously, it took a long time to build the system to do the environmental monitoring under the condition that extensive natural disaster and nuclear accidents occurred at the same time.
- The monitoring data by business operator was released on Internet or by the mass media if applicable, but from the viewpoint of promptness of release and reliability of released value, it failed to satisfy general public and the mass media.

#### **Measures to take**

- Public-private partnership such as cooperation/support in the environmental monitoring conducted by local government, and private-private partnership such as cooperation among businesses should be reconstructed. Specific details are shown below.
  - Reconfirm the monitoring equipments and facilities that are required to interchange on an emergency basis, and deploy required number of them.
  - Reconsider the dispatched personnels on an emergency basis, and clarify rules associated with the dispatch.
- Considering this natural disaster (earthquake, tsunami), the utility used for the permanent MP should be reinforced. Specific details are shown below.
  - Reinforce electric power supply and transmission line
  - Reinforce resistance characteristics to an earthquake and tsunami
- Monitoring procedure using alternative means should be clarified in case the permanent MP becomes unavailable. Specific details are shown below.
  - Reconsider the measurement procedure by use of alternative means such as temporary monitoring equipment
  - Confirm the required equipments and facilities by use of alternative means, and deploy them
- Required information and transmitted means for common people, related organization, and personnels involved should be clarified. Specific details are shown below.
  - Streamline the contents of transmitted information, how to coordinate them, and required personnels
  - Consider transmitted means (Newspaper, HP etc.) and timing of release

#### **4.10.9 Preparing disaster countermeasures (heavy equipment/rescue),**

## **emergency cooperative framework**

In this accident, extensive natural disaster and nuclear accidents occurred at the same time. Therefore, it was very difficult to do contact/communication, emergency call up, and procurement of goods etc., and it was not quickly and sufficiently to accept the materials and equipment for use in emergency measures or rescue team who support the accident management activities at the initial reaction of the accident. Also, the high radiation level at the field became an obstacle to human responses. Other conditions such as looking out for aftershock and its tsunami, darkness, high contamination status, ensuring electric power supply in anticipation of worse environmental conditions like contaminated water, arranging materials and equipment and temporary work, removing blockages to pass through on and off site, were there. These conditions greatly influenced following incident response activities.

### **Findings/lessons learned**

- Due to earthquake and tsunami, route to access such as public highway, general road, and entranceway were damaged within and outside the power plant, so it took time to bring in materials and equipment for use in incident response and to call up supporting staffs. It worked against doing the incident response activities smoothly. Materials and equipment that facilitates constrained conditions for various sort of work were expected.
- Preparing a multi-unit and coincident accident like this accident was not enough, so that protection clothing, dosimeter and mask etc. for use in incident response were not deployed in an appropriate manner. And human work under high radiation for a long time was not assumed specifically. Because preparation for work under these conditions didn't exist, incident response was not able to proceed promptly.

### **Measures to take**

Based on the above results, some examples of the countermeasures are shown below.

- On the assumption that route to access such as public highway, general road, and entranceway are blocked within and outside the power plant due to natural disaster (earthquake, tsunami), preparing heavy equipments to remove scattered wreckage and staffs and diversifying means of transport for materials and equipment are required. Considering cooperation with related organizations, specific details are shown below.
  - Clarify required heavy equipments except the loader which was deployed as severe accident countermeasures, and deploy them.
  - Establish means for sea transportation and air transport instead of land transport, and deploy the system.
- It is required to ensure required materials and equipment for use in incident response, and to reconstruct a system to interchange among business operators on an emergency basis. Considering cooperation with related organizations, specific details are shown below.
  - Clarify required materials and equipment based on the incident response of this accident, confirm required number of them, and deploy them. (including temporary light, temporary air conditioning, and temporary drainage equipment etc.)
  - Reconfirm a system to interchange among business operators on a

emergency basis and deploy means of interchange.

- Focus on a remotely-operable facility/equipment(robot, unmanned helicopter) for Nuclear Emergency Preparedness that can work under high radiation level, participate in review session associated with its development and operation, and deploy a cooperative system with business operators and related organizations for actual installation.

#### **4.11 Security of integrity of the spent fuel**

All external power sources were lost due to the earthquake. However, all emergency DGs were activated excluding one emergency DG that was under inspection. However, all of the emergency DGs excluding the 6B emergency DG of Unit 6 were stopped due to the tsunami that hit the power station afterwards. In addition, the cooling function of the spent fuel pool was lost in all units because the function of the sea water pump was lost due to the tsunami.

Further, it is considered that there is no exposure of fuel in the spent fuel pool.

##### **Findings/lessons learned**

- When the cooling function of the spent fuel pool was lost, the security of the water level of the spent fuel pool is extremely important, and maintaining and strengthening the water level of the spent fuel pool and the monitoring function of the pool water temperature are also important.
- From the viewpoint of preventing a decrease of the pool water level and damage on the spent fuel followed by the loss of cooling function of the spent fuel pool, it is considered with this accident as a turning point that new countermeasures have to be additionally prepared in order to maintain the cooling function of the spent fuel pool when all of the AC power sources were lost in a plurality of units including adjacent units and when the function of the sea water pump was lost.

##### **Measures to take**

Based on the above results, some examples of the countermeasures are shown below.

- It is necessary to secure the alternative coolant injection means to secure the water level of the spent fuel pool.
  - Supplying water by fire engines, pump trucks, etc. and securing a coolant injection route and a water source
- It is necessary to secure and strengthen the water level of the spent fuel pool and the monitoring function of the pool water temperature.
  - Securing the power source supply from the emergency power source to the water level meter and the thermometer of the spent fuel pool
  - Strengthening the monitoring function of the status of the spent fuel pool (connection of the emergency power source to the ITV, battery connection, etc.)
- It is necessary to investigate the maintainance of the cooling function of the spent fuel pool as a continuous cooling means after the water level was secured.
  - Securing the alternative cooling function of the spent fuel pool water.

#### **4.12 Summary of the countermeasures**

As described in Chapter 3 “Summary of the Causal Analysis”, to prevent reoccurrence of the accident it is important to increase the safety margin by

assuming a scenario of the accident extending and by preparing for it by taking appropriate countermeasures.

The profoundness of the system of countermeasures are summarized and outlined in Table 4.12-1 by combining the countermeasures that have already existed and the countermeasures that are exemplified here as new countermeasures.

In the causal analysis, the main cause of the extension of the accident extending was the loss of the power source, and it was described that the function of the safety components was lost due to the loss of the power source. Therefore, we decided to confirm the status of the system of countermeasures regarding the power source. Further, there was a loss of a heat sink (including the auxiliary component cooling system) as a main factor causing the loss of function of the safety components other than the power source, and a confirmation is performed from that viewpoint. Furthermore, a confirmation is performed for hydrogen because the hydrogen explosion largely affected the discharge and diffusion of radioactive substance in addition to becoming a hindrance to taking action for responding to the accident.

The countermeasures are outlined, and basically the following approach can be followed.

First, resolution of an assumed major accident at the stage of designing the countermeasures can be attempted with the safety components (the sea water pump, the emergency DG, the ECCS, etc.) that have been already installed. Reviewing what happened this time, protection of these safety components that have been already installed shall be strengthened.

The safety components that have been already installed have multiplicity and variety. Severe accident countermeasures (accident management) have been prepared independently at each nuclear power station in the 1990s by assuming a case where the functions of all of these safety components are lost. In the Fukushima Daiichi accident, most of the accident management could not be applied due to various constraints such as the loss of the power source and high contamination. Because of this, countermeasures for ready application shall be considered.

Because this accident management did not sufficiently function, severe accident countermeasures that will be added this time shall be prepared.

Therefore, as shown in the confirmation table, selectively treating the countermeasures means adding protection to the safety systems and severe accident countermeasures that have been already installed.

In such way, a layered protection system can be prepared by adding severe accident countermeasures to the safety components that have been already installed and to the accident management components, and this is considered to become an effective countermeasure for preventing progress of the accident.

#### — Power Source

The power source shall be secured surely against an earthquake and a tsunami by layered countermeasures.

- The power is supplied by an external power source during a blackout in the conventional design. However, the power source is supplied by an emergency DG when external power source is lost. Protection for this is performed.
- Assuming a case that these functions are lost, the power source is supplied by an alternative means such as deployment of a power source truck.
- Valves, etc. are individually addressed by deploying a storage battery, etc.

- Heat sink (coolant injection and cooling)
  - The core shall be certainly cooled when an accident occurs by layered countermeasures.
  - The sea water system and the ECCS component that are expected to prevent an accident from extending in the conventional design shall be protected.
  - Spares for the sea water system are deployed as countermeasures when the protection is broken. These are protected by the facility of severe accident countermeasures (accident management) against the loss of the function of the ECCS.
  - Considering a case that these do not function effectively, a pump that can separately inject water is deployed and the water source is secured. Countermeasures shall be taken for reducing the RPV pressure to secure the injection of water.
  - Countermeasures shall be taken in the BWR for certainly performing a container vent that is a final cooling means when an accident extends.
  
- Countermeasures for a hydrogen explosion
  - An explosion shall be prevented by countermeasures for each stage of the event such as prevention of hydrogen generation, prevention of leakage, and reduction of discharge.
  - The generation of hydrogen due to damage of the fuel is prevented in the conventional design by securing the cooling of the core. An explosion is prevented in the BWR by confining the generated hydrogen in a container of a nitrogen atmosphere. Therefore, the countermeasures of the water injection and cooling are effective also as countermeasures for hydrogen.
  - Hydrogen is generated when the core is damaged. However, countermeasures are taken for discharging or reducing hydrogen so that it does not stay in the building by considering that hydrogen leaks from the container because hydrogen easily leaks.
  - Countermeasures are taken for the leaked hydrogen not going into other units from a vent line.

Specifically for investigating (adapting and combining) other layered countermeasures, it is effective to consider the issues such that

- an appropriate balance shall be taken among the prevention of core damage, the prevention of container damage, and the degree of prevention,
- we shall not be biased toward administrative measures,
- the protection against possible common causal troubles shall not be decreased and new common causal troubles shall not be induced,
- independency of barriers shall not be decreased,
- preparation for human error shall be maintained, and
- functions shall be secured that are planned in a plant design standard.

In order to determine priority among individual countermeasures, the following criteria shall be used.

- The means such as the UHS and the power source which have an effect and influence on a larger number of functions are more important.
- The means and the measures having a larger contribution to the “thickness” of layers have higher priority.

- Qualitatively, an individual step is considered to be more important as the number of steps is smaller.

For example, a step that is added to one existing step is more important than a step that is added to two existing steps.

The layers of the countermeasures that are prepared are determined depending on the extent of internal and external hazards and failures.

By combining various countermeasures at this time with the countermeasures that have been considered at the stage of designing and constructing, countermeasures shall be taken that are sufficiently effective for securing safety and for effectively preventing an accident where a large amount of radioactive substance is discharged to the environment even when the prepared functions are lost one by one.

As a result of outlining the points as described above, countermeasures that are considered to have high priority from the viewpoint of preventing reoccurrence of the accident among the 80 countermeasures exemplified in the present investigative commission are identified in a Table. We suggest that these items shall be adopted in the implementation of countermeasures by each company.

— Power source

- Establishment of a tide embankment and a breakwater as a facility that is important for safety
- Prevention of flooding of the area where components that are important for safety are provided
- Prevention of soaking of an opening and a penetration part of an air supply port such as improvement of sealing the opening corresponding to the soaking height
- Sealing the sites where the transformer for receiving and the switching station are arranged from water or countermeasures for soaking of the components
- Sealing the sites where the DC power source facility is arranged from water or countermeasures for soaking of the components
- Deployment of a power source truck or a power source having a large capacity (a gas turbine or a diesel generator) and preparation of its emergency procedure
- Preparation of a DC power source charging route by the backup power source
- Improvement of reliability by countermeasures for soaking of the facility that accommodates a power source between the units (severe accident countermeasures)

— Heat sink (water injection and cooling)

- Measures for preventing soaking of a bulkhead, etc. around the sea water pump
- Disposition of spares for the sea water pump
- Prevention of soaking of areas where safety components such as the emergency core cooling system are installed
- Prevention of soaking of the facility for severe accident countermeasures
- Disposition of a movable coolant injection pump
- Preparation of the backup power source for driving the SRV, spare air tanks,

- etc. (BWR)
  - Security of the core cooling through the SG by a main vapor releasing valve (PWR)
  - Disposition of a backup power source for operating a vent and a driving source (BWR)
  - Improvement of reliability of the coolant injection system by deployment of a backup power source truck and a power source having a large capacity
  - A portable power pump, a hose, etc. that do not depend on the existing facility
  - Security of the water source
  - Releasing heat to the air by the container vent (BWR)
- Hydrogen
- Discharge and decrease of remaining hydrogen
  - Prevention of wraparound of hydrogen from a pressure resistant strengthened vent line
  - Prevention of wraparound of hydrogen between the units sharing an exhaust pipe

Further, countermeasures are combined by considering safety of the plant as a whole and selecting for implementation. Various combinations of the countermeasures can be considered corresponding to the condition of each power station and the strategy for securing safety, and they are not limited to the above-described countermeasures. All countermeasures that were identified are summarized and shown in Fig. 4.12-1.

Table 4.12-1 Checklist processed in terms of defense in depth

		Prevent accident occurrence		Mitigating the impact of accident			
Multiple levels of protection		First layer (normal operation)	Second layer (Anomaly in the expected operation)	Third layer (Design basis accident and event during combined operation)	Fourth layer (Severe accident)	Fifth layer (Severe accident)	
Purpose		Prevention of abnormal operations and failures	Control abnormal operations and detect failures	Control the accidents in the design base	Progress in preventing accidents	Mitigation of SA	
Mandatory measures		High quality in conservative design, construction and operation	Control, limitation and protection systems	ECCS and accident procedures	Complementary measures and accident management	AM included the protection of complementary measures and PCV	
Core	Source	Before earthquake	<ul style="list-style-type: none"> <li>Assess the expected tsunami height by basic design earthquake ground motion. Tsunami with the height greater than site height is not expected.</li> <li>Supply the power by external power source if the power generation of the plant is stopped.</li> <li>Evaluated that seismic capacity of transmission tower is enough. Implementation of measures to improve the seismic reliability are in process.</li> </ul>	<ul style="list-style-type: none"> <li>Backup with emergency DG when there is a loss of AC power. Install 100% emergency DG in 2 systems serially.</li> <li>Assure independence for power supply by installing the steam-driven equipment's</li> <li>The water immersion through the openings such as building discharge valves by tsunami are not considered.</li> </ul>	<ul style="list-style-type: none"> <li>Not considered the flooding.</li> <li>Ensure the emergency D/G and power of DC battery.</li> </ul>	<ul style="list-style-type: none"> <li>It is estimated that AC power is restored early (in about 8 hours), long term power supply is not expected.</li> <li>The core cooling will be performed by DC-powered equipment after station blackout and AC power will be restored.</li> </ul>	<ul style="list-style-type: none"> <li>Improve the flexibility of power between the Unit as AM measure. However, the loss of power for multiple units at the same time is not expected.</li> </ul>
		Proposed measures	<ul style="list-style-type: none"> <li>Setup the storm surge barrier and breakwater in the important safety related equipment.</li> </ul>	<ul style="list-style-type: none"> <li>Measures to prevent water immersion into the vital areas of safety related major components</li> <li>Measures to prevent water immersion through the openings like air supply opening depending on the height of water by improving seal for penetration area</li> </ul>	<ul style="list-style-type: none"> <li>Anti-flood device or water tightness of arrangement parts for switchyard and receiving voltage converter</li> <li>Anti-flood device or water tightness of vital arrangement parts of D.C. power supply system</li> <li>Place the drainage pump for movable</li> </ul>	<ul style="list-style-type: none"> <li>Place power unit or high-capacity power supply (diesel generators and gas turbines), develop emergency procedures</li> <li>Develop root of DC power supply by backup power source</li> </ul>	<ul style="list-style-type: none"> <li>Improve reliability through the tsunami measures of the power interchange facilities between different units</li> </ul>
	Heat sink (Injection/cooling)	Before earthquake	<ul style="list-style-type: none"> <li>Assess the expected tsunami height by the latest knowledge of construction engineer. The measures for these has already been carried out.</li> </ul>	<ul style="list-style-type: none"> <li>Install the series of 2 100% Sea water systems or 4 50% Sea water systems. Ensure the diversity.</li> <li>Enable handling of transient by operational action without safety system equipment's such as ECCS etc.</li> <li>The loss of functionality of all equipment's at the same time due to the immersion of water into Sea water pump and power panel is not expected.</li> </ul>	<ul style="list-style-type: none"> <li>Install a series of 2 safety systems such as ECCS.</li> <li>Install systems (IC, HPCI, RCIC) that function only with DC power supply.</li> <li>Multiplicity, diversity and independence has been ensured.</li> <li>Although sea water system has unwanted HPCI and RCIC in the cooling of oil and bearing, if the DC power supply is cutoff, it will fail to operate.</li> </ul>	<ul style="list-style-type: none"> <li>Develop measures for severe accidents (accident management). Use the existing equipment as alternative injection facility if required.</li> <li>Loss of power and flood is not expected.</li> <li>No alternative driving sources for various types of valves.</li> </ul>	<ul style="list-style-type: none"> <li>No development of injection measures other than AM measure.</li> </ul>
		Proposed measures	<ul style="list-style-type: none"> <li>Measure to prevent the water immersion like bulkhead around the Sea water pump</li> </ul>	<ul style="list-style-type: none"> <li>Place the spare part for sea water pump motor</li> <li>Wash the sea water pump motor and place the dry material</li> </ul>	<ul style="list-style-type: none"> <li>Measures to prevent the water immersion in the vital areas related to Emergency Core Cooling System</li> <li>Install waterproof pumps</li> </ul>	<ul style="list-style-type: none"> <li>Place mobile injection pump</li> <li>Prepare SRV drive backup power supply and spare air cylinders etc.</li> <li>Ensure the injection procedures by deploying the backup power unit or high-capacity power supply</li> <li>Measures to prevent water immersion into AM system</li> <li>Portable pumps and hoses independent of existing power supply</li> <li>Ensure river head (also include sea water as last resort)</li> <li>Loose heat to atmosphere by containment vent (emission of heat from S/C)</li> <li>Deploy the backup power supply and drive source for Vent operation</li> <li>Optimization of operating conditions of vent</li> </ul>	<ul style="list-style-type: none"> <li>Loose heat to atmosphere by containment vent (guarantee the containment integrity)</li> <li>Deploy the backup power supply and drive source for Vent operation</li> <li>Optimization of operating conditions of vent</li> <li>Ensure the injection, injection route and river head due to fire</li> </ul>
	Hydrogen (H)	Existing state *			<ul style="list-style-type: none"> <li>Prevent hydrogen generation by core cooling due to ECCS etc.</li> <li>Set well below the flammability limit even though there is a hydrogen leakage by encapsulating the nitrogen in the PCV and by setting inactivated environment.</li> </ul>	<ul style="list-style-type: none"> <li>Hydrogen leakage is likely to occur from containment if core is damaged.</li> <li>Reverse flow of gas between the units is not considered.</li> </ul>	
		Proposed measures				<ul style="list-style-type: none"> <li>Reduce emission of retained hydrogen</li> <li>Measure to prevent wraparound from pressure reinforced vent line</li> <li>Prevent hydrogen wraparound in the different units that share the vent stack</li> </ul>	<ul style="list-style-type: none"> <li>Reduce the emission of retained hydrogen in the containment</li> </ul>
SFP	Injection, cooling, source, water level	Before earthquake	<ul style="list-style-type: none"> <li>Install the equipment with sufficient cooling capability for decay heat of maximum storage capacity.</li> </ul>	<ul style="list-style-type: none"> <li>Set the height of discharge pipe above the required water level and maintain the required water level even though there is a leakage in pipe due to siphon break.</li> <li>Contains the supply function of river head of seismic S class. Maintain the water level by supplying the water from water supply system.</li> </ul>	<ul style="list-style-type: none"> <li>Loss of cooling procedure is not expected.</li> </ul>		
		Proposed measures			<ul style="list-style-type: none"> <li>Ensure the injection route and river head due to fire</li> </ul>	<ul style="list-style-type: none"> <li>Ensure alternative cooling function (or early recovery of auxiliary cooling system)</li> </ul>	

— PREPARATION AGAINST EARTHQUAKES, TSUNAMI 1, 6, 7, 9, POWER SUPPLY PREPARATION 3, 5, CORRESPONDING HEAT SINK LOSS (BWR) 2, 4, 8, 10, 11

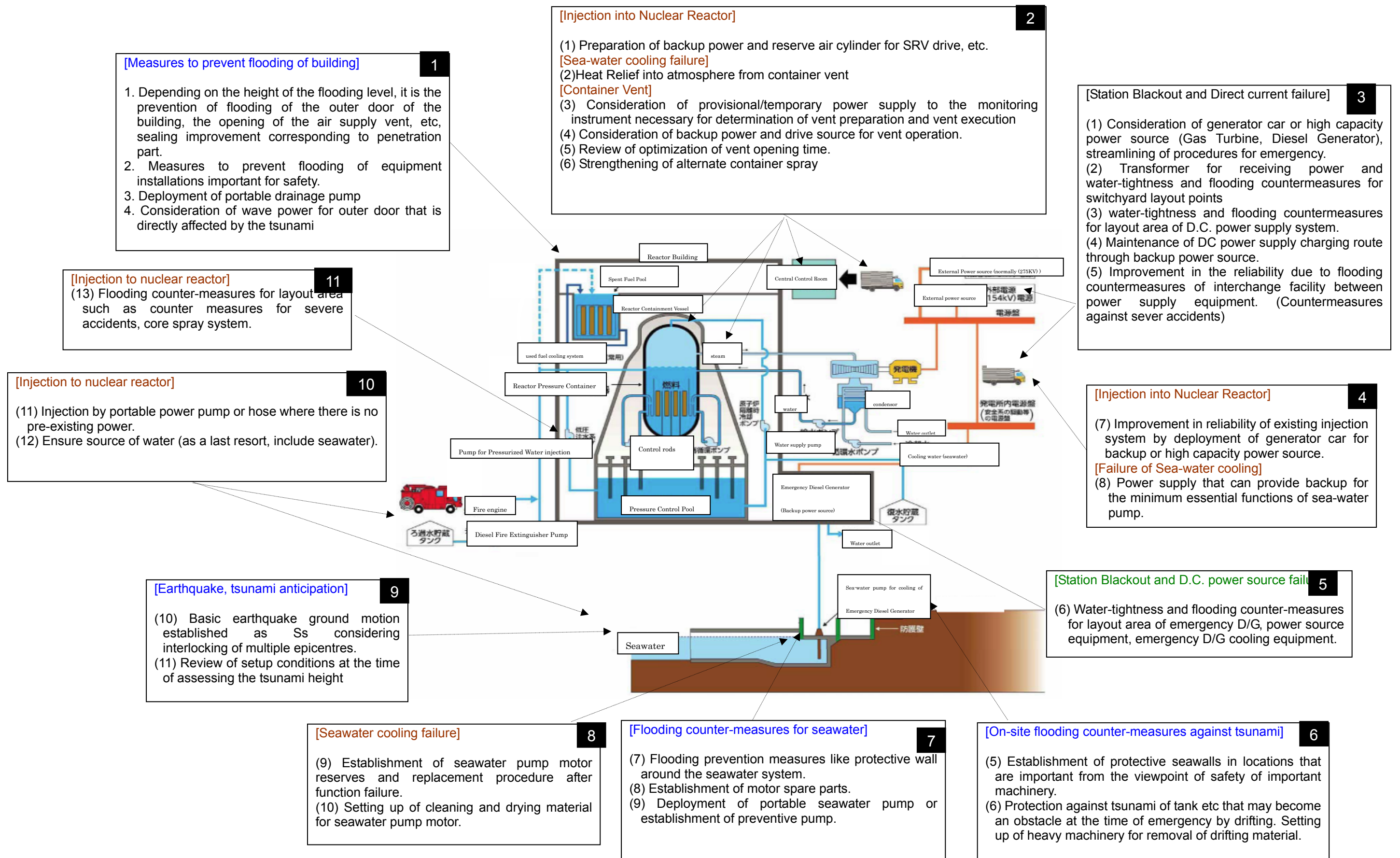

Figure 4.12-1 Examples of Countermeasures 1/3

- Hydrogen Countermeasures 14 | Emergency Preparedness 12, 15, 16, 17, 18, 20, 21, Integrity Assurance of Used Fuel 13, 19 -

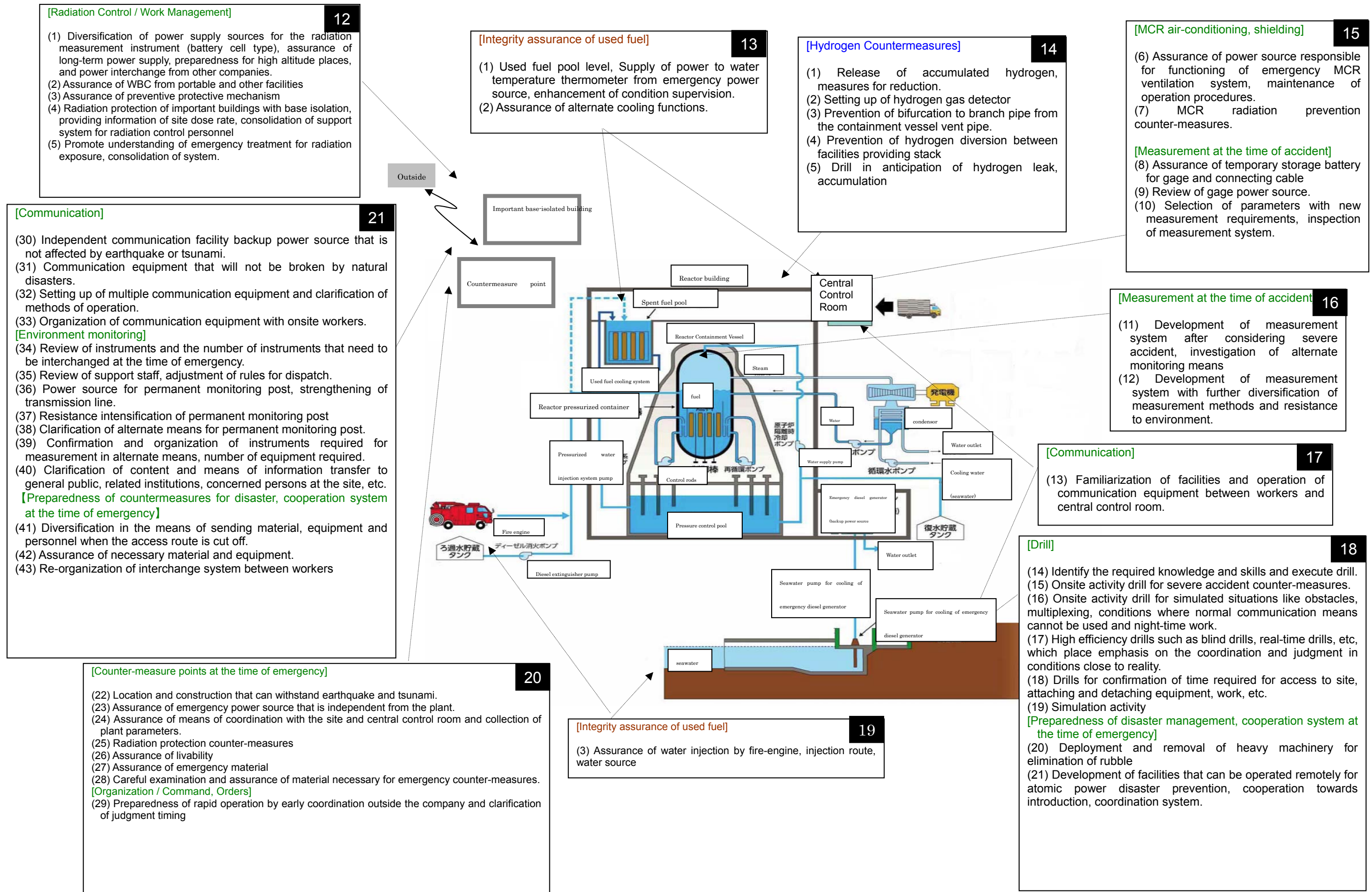

Figure 4.12-1 Examples of Counter-measures 2/3



## Chapter 5 Timeline of the Accident to the Present

The Tohoku earthquake and tsunami which occurred at 2:46 PM on March 11, 2011 struck the Fukushima Daiichi and Daini Nuclear Power Stations, a long-term nuclear accident unprecedented in scale.

In units 1 to 3 of the Fukushima Daiichi Nuclear Power Station, water continued to be unable to be injected into the RPV for a period, exposing the fuel in the cores and leading to core meltdown. A portion of the melted fuel pooled below the RPV.

A large quantity of hydrogen was produced from a chemical reaction between zirconium in the cladding and other fuel rod parts and steam, the fuel rod cladding was damaged, radioactive substances in the fuel rods were released into the RPV, and hydrogen and radioactive substances were released into the storage container during the RPV decompression process.

The internal pressure in the RPV that lost core cooling functionality rose and leaked into the storage container through the safety valve, raising the pressure inside the storage container. To prevent damage to the containment buildings of units 1 to 3, they were vented to the wetwells a number of times.

After the venting of the first and third units, an explosion thought to be caused to hydrogen leaking from the containment building occurred in the upper part of the reactor building and the operation floor collapsed.

An explosion which appears to have been caused by hydrogen occurred in the nuclear building of the unit 4, destroying the upper portion of the building. Around 6 AM on March 15, the sound of a large impact was confirmed, but at this time, it is not clear whether this was due to a hydrogen explosion, or the location where it occurred. Nearly simultaneously, the S/C pressure indicated 0 Mpa (abs), and the reason for that is unclear.

Cooling of the used fuel pools for units 1 to 4 was shut down due to the loss of power, and the evaporation of water due to heat from the used fuel caused the water level to continue to drop. To address the water level, helicopters and spray vehicles were used to inject water into the used fuel pools, though ultimately a concrete truck pump was secured, which pumped seawater, followed by freshwater.

On March 11, the government declared a nuclear emergency situation and established a Nuclear Emergency Response Headquarters and a Local Nuclear Emergency Response Headquarters, with the prime minister serving as the director-general. Further, on March 15, the Accident Measures Integration Headquarters was established to integrate efforts of the government and nuclear operators.

On March 11, the Nuclear Emergency Response Headquarters set the area within a three-kilometer radius from Fukushima Daiichi as an evacuation zone and the area within a three- to 10-kilometer radius as an indoor evacuation zone. On March 12, with subsequent development of the accident, the area within a 20-kilometer radius was established as an evacuation zone and that within a 20- to 30-kilometer radius as an indoor evacuation zone. On April 21, the area within a 20-kilometer radius was established as a no-entry zone, with only restricted entry allowed.

Although the Local Nuclear Emergency Response Headquarters was initially established off-site, it was subsequently moved to the Fukushima Prefectural Office when the location subsequently became a high-radiation environment, causing communication interruptions and impeding logistics.

The provisional assessment of the accident according to the INES was initially a level 3 due to the determination of inadequate water in the emergency core cooling system on March 11. On March 12, this was raised to level 4 due to the state of radioactive material emissions, and on March 18, it was raised to level 5 in response to an increase in the quantity of radioactive material being emitted. On April 12, the total quantity of emitted radioactive material was determined to be roughly one-tenth of that of Chernobyl, and the level was raised to level 7.

As a result of the total loss of AC power at Fukushima Daiichi, the internal Personal Handy-phone System (PHS) and Safety Parameter Display System for ascertaining station status became non-functional.

The Emergency Response Support System (ERSS) for predicting nuclear core status and developments during a nuclear accident was unable to obtain the required station information and was otherwise unable to perform its primary functions. Further, the System for Prediction of Environment Emergency Dose Information could not acquire emission source data or otherwise perform its primary function of making quantitative predictions, including how the concentration of radioactive materials in the atmosphere would change.

Towards restoration of the power facilities, power supply vehicles from all branches were dispatched to Fukushima Daiichi; however, progress was impeded by road damage and traffic congestion. Air transport of the power supply vehicles could not be provided by the Self-Defense Forces because the power supply vehicles were beyond their weight capacity. Before daybreak on the 12th, power supply vehicles that had been secured were used and cables laid with the aim of restoring power. On March 15, external power was restored to the internal switching stations for units 1 and 2, and on March 24, MCR lighting was restored for unit 1. Further, on March 18, external power was restored to the mobile M/C installed on the unit 3 premises, and on March 22, MCR lighting was restored for unit 3.

Taking into account the records collected from MCR and other locations as well as the operating status of equipment, a Modular Accident Analysis Program composed of severe accident analysis code was used to assess the status of the reactor core, and found that in the most rapid scenario, fuel exposure began approximately two hours after the tsunami struck and approximately three hours after the earthquake struck, with core damage occurring about one hour after that. As no water was being injected into the nuclear core at that time, melting of the fuel progressed, and when water injection commenced around 6:00 AM on March 12, the melted fuel had already migrated to the lower part of the RPV, and apparently leaked to the containment vessel.

At unit 2, fuel exposure apparently began approximately four hours after 1:25 PM on March 14, when it was determined that the RCIC shut down, approximately 75 minutes after the earthquake struck, followed by damage to the core approximately two hours later. At unit 3, fuel exposure apparently began approximately four hours after 2:24 A.M. on March 13 when it was determined that the HPCI shut down, approximately 40

minutes after the earthquake struck, followed by damage to the core approximately two hours later.

With regards to stable cooling of the nuclear reactors, before carrying out the flooding operation (filling the containment vessel with water up to the upper fuel region) initially planned, a review was made and it was decided to establish a “recycled water injection cooling” to process contaminated water that had accumulated in the reactor building for reuse as nuclear reactor injection. Additionally, the reliability of the injection water was ensured (with measures to address abnormalities and multiple water injection methods), a hydrogen explosion was avoided through filling the containment vessel with nitrogen, and “stable cooling” was reached, the second step of the road map.

Currently, the temperature of each part of the RPV has stabilized, and the temperature of the bottom portion of the RPVs at units 1 and 3 is stable at no greater than 100°C. The quantity of injection water was experimentally varied at unit 2, and a stable temperature of no greater than 100°C was confirmed for the bottom portion to the RPV.

Concerning cooling of the used fuel pools, a heat exchanger was used for circulating cooling at all units, 1 to 4, and “more stable cooling” was achieved, step 2 of the road map, by August 10.

Seawater and underground water from the tsunami, as well as water injected into the nuclear reactor and used fuel pools leaked, resulting in an accumulation of highly radioactive water in the reactor building, which leaked to the cable trenches outside and then to the ocean from cracks in the concrete frame. Measures were taken to prevent leakage to the ocean, including capping the trenches and stopping the water; additionally, treatment equipment was installed to treat the accumulated water so that the water level would not overflow. To carry out treatment of the accumulated water and inject it into the nuclear reactor in a stable, efficient manner, an evaporation-concentration apparatus was put into service on August 7 as a second line of treatment equipment to increase the desalting capacity, and the operation moved forward smoothly. On October 9, the augmentation of the salt treatment equipment with evaporation-concentration apparatuses was completed, making nuclear reactor water injection more stable.

Currently, progress is at the second step of the road map, and work on measures to control the release of radioactive materials is progressing.

## Chapter 6 Conclusion

The accident at the Fukushima Daiichi Nuclear Power Station has engendered distrust in nuclear power not only in Japan but around the world as well.

Cause analysis and recommendations for action have been provided by a variety of agencies, including a national accident measure commission. In this report, electrical operators having the primary responsibility for construction and operation of nuclear power stations have worked with electrical engineers directly involved with the design and construction of power stations, voluntarily summarizing the results of their impartial analysis of the causes of the accident, their deductions of the most significant lessons to be learned, and countermeasures they have considered.

JANTI is composed of many companies involved in the nuclear power industry as well as electrical operators, and through this association, power engineers and station engineers have been able to come together to hold discussions. The positions of power production and station construction were separated, and the abilities of experienced specialists were employed to objectively study the issues from an engineering perspective to further delve into the results that were assembled by the power and station specialists. These efforts were also reflected in this report.

Furthermore, specialists of the technical analysis subcommittee of the Atomic Energy Society of Japan have provided a review of this report, providing additional perspectives.

Central to this investigation have been the cause analysis into why it was not possible to avoid core meltdown at the Fukushima Daiichi Nuclear Power Station after the tsunami struck and proposals for countermeasures. In short, the factors may be summarized as being that the cooling, control and monitoring functions of the internal electrical equipment, particularly the emergency AC and DC electrical panels were lost due to incoming water, and that due to the time required to establish a reactor core cooling means as an alternative to the regular power supply, flooding of the reactor core could not be maintained. At power stations around Japan, emergency safety measures have already been implemented for the present to prevent incidents caused by tsunamis, and through this investigation, multilayered countermeasures have been deduced, including those already implemented in power stations throughout Japan and those planned for implementation.

In this investigation, however, it was not possible to directly interview the operators working at the time of the accident. By conducting an investigation with a perspective focused on finding room for improvement, if only to alleviate the burden on the station operators, the experience of operating during such an emergency situation could likely be used to acquire knowledge useful in further improving measures against other incidents.

Recommendations in this investigation on alleviating the effects of post-meltdown radioactive materials on the environment, estimates and criteria of the quantity of radioactivity that people in the vicinity were exposed to, measures for resident evacuation facilities, and disaster-related matters such as information dissemination and disclosure, and a system for instructions and orders were based solely on information obtained from the industry. In relation to these matters, however, there are likely to be many issues that ought to be reconsidered and many lessons to be learned when the perspectives of people in the local communities and others are taken into consideration, and those issues should be the focus of investigations going forward.

When engineers design facilities, they must ensure that certain conditions, including regulations, are satisfied. The thinking of the people who set those conditions is

susceptible to various influences, and phenomena may occur that exceed those conditions. Given this premise, it may be that the most important lesson that nuclear power engineers should learn from this accident is that they should appreciate anew the importance of continuing the search for rational means to solve engineering issues. Particularly when your adversary is a natural phenomenon such as a tsunami, it is critical to take yet another look at whether any of a variety of methods are needed to minimize the effects of a phenomenon should it exceed expectations. Deep consideration should also be given to the import of the words, "The prime responsibility for safety must rest with the person or organization" in the IAEA's Fundamental Safety Principles. Moreover, it is surely the responsibility of the engineer to continuously, repeatedly question safety without falling into the illusion that satisfying regulatory requirements is an adequate discharge of one's duties, and we should demand that nuclear engineers recall to mind what their purpose is in being engineers.

Whether such investigations will be conducted with due seriousness and without getting caught up in the past history, and whether the results of those investigations will be reflected in stations to improve safety is truly a call to the ability of the nuclear power industry and to each and every nuclear engineer. It is hoped that the industry and engineers will return to the roots of their calling as engineers and move forward in making on-going improvements.

The investigation described in this report was conducted based on information currently available, as described above, and was carried out with our best efforts. When others view the report from their various perspectives, they will likely notice many oversights and consider measures superior to those offered here. We hope that the reader will subject this report to the strictest of scrutiny and point out all such shortcomings.

In closing, as members of the Fukushima Daiichi Nuclear Power Station Accident Investigation Commission, we would like to express our deep gratitude to all of those who earnestly participated in the long, frequent discussions despite the heavy workload that dealing with the accident entailed for all concerned.

## **Appendix-1 A Comparison of the Development of the Accident at the Fukushima Daiichi Nuclear Power Station and at Other Stations (Detailed Version)**

Section 3.6 “Comparison to Other Stations” summarizes a comparison of Fukushima Daiichi units 1 to 3 to Fukushima Daini, Onagawa and Tokai Daini. Details for each station are provided below.

### **A Summary of the events at the Fukushima Daini Nuclear Power Station**

Although the functionality of the sea water cooling systems were lost at the Fukushima Daini units 1, 2 and 4 due to the tsunami, RCIC operation ensured the capability of reactor core cooling, and subsequently, a make-up water system was used to provide an alternative means for injecting water into the nuclear reactors and containment vessels. As a result, cooling of the reactor cores and SFP fuel was maintained for roughly three days without venting the containment vessels. Meanwhile, the sea water system was restored, and residual heat removal functionality was finally restored through the resumption of the RHR equipment, and a transition was made to a cold shutdown. Because the power supply was secured, it was possible to secure extra time by utilizing safety equipment for serious accidents even without the functionality of the sea water system, and it was possible to transition the station into a safe state.

At unit 3, reactor core cooling was ensured with RCIC operation, followed by injection of water from an alternate source. The residual heat removal system using RHR was secured with the B system.

The development of events at Fukushima Daini are shown in an event tree in Appendix 1-1.



## **(1) The effects of the earthquake and tsunami**

### **a. The effects of the earthquake**

The maximum acceleration rate obtained in the reactor building base mat (the bottommost underground floor) due to the earthquake was confirmed to be less than the maximum response acceleration for basic earthquake ground motion S<sub>s</sub>, formulated to include the revised guidelines for seismic design review.

Also, although the response spectrum of the seismological record exceeded the response spectrum for basic earthquake ground motion S<sub>s</sub> during a portion of the periodic band, it was confirmed as generally being equivalent or lower.

The seismological record was used to analyze the seismological response of the critical safety equipment, and it is believed that the safety functions were secure during and subsequent to the earthquake.

### **b. The effects of the tsunami**

A study on the tsunami caused by the Tohoku earthquake that struck on March 11 showed that the water level and tsunami flooded areas on the ocean side and major building and equipment areas were as follows (ground movement due to the earthquake is not included):

#### **1) Water level**

##### **(a) Ocean side area (site O.P. + 4 meters)**

- Approximately + 7 meters\* (tsunami water depth, approximately 3 meters)

\* There were local levels that were higher such as on the south side of the unit 1 heat exchanger building.

##### **(b) Primary building and equipment area (site O.P. + 12 meters)**

- Approximately + 12 to 14.5 meters\* (tsunami water depth, approximately 2.5 meters or lower)

\* Locally, O.P. + approximately 15 to 16 meters from the south side of the unit 1 building to the base-isolation structure

(Flooding depth: approximately 3 to 4 meters)

#### **2) Flooded areas**

(a) Although the entire ocean side area was affected, flooding was not found in the main building and equipment area beyond the slope of the ocean side area

(b) Flooding was concentrated on the roads from the southeast side of the main building and equipment area to the base-isolation structure, and the building environments of units 1 and 2 as well as the south side of the building of unit 3 were inundated (there was no flooding near the building of unit 4)

## **(2) Unit 1**

### **a. Station behavior upon occurrence of the earthquake**

During the constant operation at the rated thermal output, Unit 1 automatically shut down at 14:48 p.m. on March 11, 2011 due to the "earthquake-accelerated large trip" caused by the earthquake occurred at 14:46 p.m. on the same day (the epicenter was Sanriku-oki). The maximum acceleration observed was 305 gal at the second floor of the basement of the Unit 1 building of the nuclear power station. All reactors automatically shut down because their protection system became activated properly as designed. Immediately after the automatic shutdown of the reactor, the following facts were confirmed: the reactor was subcritical; all control rods were fully inserted; and all the facilities required for cold shutdown of the reactor and cooling of SFP were in normal and stable conditions.

However, such facilities required for cold shutdown of the reactor and cooling of SFP became disabled by the tsunami which occurred after the earthquake (the

first wave of the tsunami was visually confirmed at 15:22 p.m. on the same day, March 11). In addition, due to loss of the reactor's heat removal function, S/C could not be cooled down, Therefore, the S/C water temperature gradually increased to over 100°C.

Subsequently, in order to partially restore the facilities required for cold shutdown of the reactor and cooling of SFP to their usable states, the flooded facilities were inspected and repaired, and power was supplied from a temporary power source. After recovering the heat removal function of the reactor, the S/C water was cooled down to a temperature lower than 100°C. Since then until 17:00 p.m. on March 14, the reactor's water temperature had been maintained at a temperature lower than 100°C (i.e., in the cold shutdown state) through the RHR1 system, while at the same time the SFP system had been continuously cooling down. Currently, the station is under stable conditions.

**b. State of the “shut down” function**

Upon occurrence of the “earthquake-accelerated large trip” at 14:48 p.m. caused by the earthquake (at the second floor of the basement of the reactor building, set point for operation in a vertical direction: 100 gal), all control rods were fully inserted immediately. The reactor automatically shut down as designed, and the reactor became subcritical at 15:00 p.m. on the same day.

At 05:58 a.m. on March 12, the alarm went off, detecting the abnormality in the position indicating probe (hereinafter referred to as PIP) of the control rod 10-51. Although the alarm condition was cleared once at 10:30 a.m. on the same day, this situation was repeated several times. There are two ways to indicate the control rod position. One is to indicate the “full insertion” state. The other is to indicate the position of the rod itself. When the alarm went off, while the PIP's “full insertion” indicator lamp was not on, the position indicator lamp was indicating that the control rods were fully inserted. When the alarm condition was cleared, the full insertion indicator lamp was on.

Furthermore, when the alarm went off, no significant change was observed in indication of the start-up range neutron monitor (hereinafter referred to as SRNM) and the reactor's subcritical state remained unchanged. Although the alarm condition was cleared at 12:02 p.m. on March 13, the control rods were isolated (bulb-out) at 15:18 p.m. on the same day to avoid activation. Since then, no significant change has been observed in the SRNM indication and the reactor's subcritical state has been maintained.

**c. State of the “cooling” function**

Immediately after the automatic shutdown of the reactor, the reactor output rapidly declined, thus decreasing the void in the reactor core. As a result, the reactor water level dropped to the “reactor water level low (L-3).” Subsequently, the reactor water level returned to the automatic-initiation water levels\*2 of the ECCS pumps\*1 and the RCIC system without any fall due to the water supply from the reactor feed water system.

\*1 ECCS pumps (common among reactors 1 to 4 of this power station)

- HPCS pump
- Low-pressure core spray (hereinafter referred to as LPCS) pump
- RHR pumps (A, B, C) low-pressure coolant injection (hereinafter referred to as LPCI) mode

\*2 Automatic-initiation water levels (common among reactors 1 to 4 of this power station)

- HPCS and RCIC •••••••L-2
- LPCS and RHR (LPCI) •••••••L-1

MSIV was completely closed at 15:36 p.m. on March 11 and the reactor pressure was controlled through SRV in preparation for the following situations: the circulation water pump (hereinafter referred to as CWP) may shut down due to a tsunami, and may thus cause malfunction of the main steam condenser; and the turbine gland sealing steam may become lost due to the auxiliary boiler shutdown caused by earthquakes. Furthermore, upon full closure of the MSIV, the RCIC system was manually activated at 15:36 p.m. on the same day in order to pour water onto the reactor. After the RCIC system automatically shut down at 15:40 p.m. on the same day due to the “reactor water level high (L-8)” the reactor water level was adjusted via the manual activation and automatic shutdown of the RCIC system.

It was decided that none of the pumps for the emergency equipment cooling system<sup>\*3</sup> was activatable (it was later confirmed at the scene that some motors and emergency power supplies (P/C 1C-2, 1D-2) were unusable due to submersion) because the sea water heat exchanger building was flooded by the tsunami and the operation/shut down indication lamp indicated that these pumps shut down. All the ECCS pumps therefore became unactivatable, thus causing loss of the reactor’s residual heat removal function. Moreover, the emergency power supplies (M/C 1C and 1HPCS) became unusable due to submersion of the annex of the reactor building caused by the tsunami, thus causing the unactivatable conditions to the LPCS pump, RHR pump (A) and the HPCS pump.

\*3 Pumps for the emergency equipment cooling system:

- Residual heat removal cooling system (hereinafter referred to as RHRC pumps) pumps (A, B, C, D)
- Residual heat removal cooling system via sea water (hereinafter referred to as RHRS) pumps (A, B, C, D)
- Emergency exchanger cooling water (hereinafter referred to as EECW) pumps A, B)
- High pressure core spray system (hereinafter referred to as HPCSC) pump
- HPCS cooling sea water system (hereinafter referred to as HPCSS) pump

Initially, water was poured onto the reactor using the RCIC system. However, the alternative method using MUWC was introduced at 00:00 a.m. on March 12 as the countermeasure for severe accidents and implemented along with the RCIC system for pouring water. Furthermore, rapid reactor depressurization was initiated at 03:50 a.m. on the same day because the relationship between the reactor pressure and the S/C water temperature turned the situation into the operation prohibition status because of the heat capacity limitation. The RCIC system was manually shut down at 04:58 a.m. on the same day due to the decrease in the pressure of the steam to drive the RCIC turbine due to the rapid depressurization of the reactor. Subsequently, the reactor water level was adjusted through the alternative water pouring method using MUWC.

At 17:35 p.m. on March 11 the alarm went off after detecting the state of “D/W pressure high” (set point: 13.7kPa [gage]). There was an entry (system A) describing the state of “MSIV reactor water level low (L-2)” in the alarm typer that was recorded at 15:37 p.m. of the same day.

It was later discovered that the state of “MSIV reactor water level low (L-2)” (system A) was caused by loss of the MSIV trip logic circuit power supply due to

shutdown of the AC120V station vital panel board 1A that was caused by the tsunami. Although the automatic activation signals of all the ECCS pumps properly worked upon detection of the "D/W pressure high" state, of those ECCS pumps, the LPCS pump, the RHR pump (A) and the HPCS pump did not automatically activate because of the unavailable emergency power supplies (M/C1C, 1HPCS). Also, the RHR pumps (B, C) were manually shut down because the RHRC pumps (B, D), the RHRS pumps (B, D) and the EECW pump (B) were unusable. After this incident, the preventive measure for automatic activation (the control switch is maintained at the "pull" position) was undertaken.

Subsequently, the S/C water temperature increased to a temperature over 100°C at 05:22 a.m. on March 12. It further increased up to approximately 130°C (at 11:30 a.m. on March 13). At 06:20 a.m. on March 12 in order to cool down the S/C, the coolant (MUWC) was poured into the S/C from the cooler of the flammability (flammable gas) control system (hereinafter referred to as FCS) via the coolant drainage line. At 07:10 a.m. on the same day the alternative method using MUWC was undertaken. D/W spraying was initiated at 07:10 a.m. and the cooling method was switched to the S/C spraying at 07:37 a.m. Thus PCV alternative cooling was conducted by alternating these two methods according to the situation.

Furthermore, along with the implementation of the alternative water pouring method using MUWC, the PCV alternative cooling method and the S/C cooling method using the FCS coolant (MUWC), the following pumps were inspected and repaired: the PHRC pump (D); the RHRS pump (B); and the EECW pump (B). (Motors were replaced for the RHRC pump (D) and the EECW pump (B).) Additionally, because the sea water heat exchanger building was submerged and the emergency power supplies (P/C 1C-2, 1D-2) were flooded, the RHRC pump (D), the RHRS pump (B) and the EECW pump (B) were restored to their activatable state by supplying power from the temporarily installed cable, which received electricity from the power source (P/C 1WB-1) in the radioactive waste treatment building, which in turn received electricity from external power supply system and a high voltage power supply vehicle, which was urgently procured outside the power station. These pumps were activated one by one at 20:17 p.m. on March 13.

Subsequently, the RHR pump (B) was activated at 01:24 a.m. on March 14. Also, as a result of S/C cooling using the RHR pump (B), the S/C water temperature gradually dropped to a temperature lower than 100°C at 10:15 a.m. on the same day.

Furthermore, in order to cool down the reactor water as well as the S/C water at an early stage, the implementation procedures were created based on the predetermined emergency operation procedures. At 10:05 a.m. on the same day the procedure to pour the S/C water onto the reactor via the LPCI line was initiated using the RHR pump (B), while at the same time temporarily cooling the reactor via the circulation line, through which the reactor water was allowed to flow into the S/C through the SRV, and the S/C water was cooled using the RHR heat exchanger (B), then again poured back into the reactor via the LPCI line (S/C → RHR pump (B) → RHR heat exchanger (B) → LPCI line → reactor → SRV → S/C). Through this operation, it was confirmed that the reactor water temperature dropped to a temperature lower than 100°C at 17:00 p.m. on the same day, and thus cold shutdown was confirmed.

As described above, although the reactor's cooling function was temporarily lost,

water was continuously poured onto the reactor. As a result of the reactor water sampling conducted after the incident, the level of iodine-131 was lower than the detection threshold. Therefore, it did not damage the fuel.

**d. State of the “trapping” function**

When the alarm went off detecting the state of “reactor water level low (L-3)” when the reactor automatically shut down, the Primary Containment Isolation System (hereinafter referred to as PCIS) and the SGTS properly worked. Therefore, the PCV was isolated, and the negative pressure in the reactor building was maintained. Although the PCV pressure increased up to approximately 282kPa [gage] (at the S/C side), it did not reach the PCV maximum allowable working pressure of 310kPa [gage].

In addition, no abnormal change was observed in the stack radiation monitor or the MP value. It was therefore confirmed that no radiation affected the environment outside the building.

Moreover, assuming that the PCV pressure was going to increase and that it would take a while to recover the reactor heat removal function, a PCV pressure-resistant vent line (the state in which one action for operating the outlet valve at the S/C side was left undone) was created.

**e. State of the spent fuel pool cooling system**

With regard to systems required for cooling the SFP, the SFP water level was maintained higher than the overflow through the FPC system, and the SFP water temperature was maintained at approximately 38°C before the occurrence of the earthquake. However, the SFP cooling through the FPC could not be continued because the coolant could not be supplied to the FPC heat exchanger due to the disability of some pumps for the following reasons: the FPC pump tripped (“skimmer surge tank water level low” or “pump suction pressure low”) due to the earthquake; the auxiliary sea water system (hereinafter referred to as SW) pump (A, B, C) of the closed cooling water system located near the outside intake was flooded by the tsunami; and the reactor building closed cooling water system (hereinafter referred to as RCW) pump (A, B, C) located at the lower ground floor one in the sea water heat exchanger building was submerged by the tsunami.

Consequently, the SFP water temperature increased up to approximately 62°C. Therefore, the operation to pour water into SFP using the fuel pool make-up water system (hereinafter referred to as FPMUW) was conducted at 16:30 p.m. on March 14, and the water circulation operation using the FPC pump (B) was initiated at 20:26 p.m. on the same day to cool the SFP. Subsequently, at 00:42 a.m. on March 16 the SFP cooling operation was conducted using the RHR pump (B). By 10:30 a.m. on the same day, the SFP water temperature returned to approximately 38°C, which was the temperature prior to the occurrence of the earthquake.

As a result of the above countermeasures, although the SFP system temporarily lost its cooling function, it satisfied the operational limits (SFP water level: near overflow water level, water temperature: 65°C or lower) stipulated by the Safety Preservation Rules of Nuclear Facilities.

**f. State of the “power supply” function**

Although all the power supplies in the station were in usable conditions

immediately after the automatic shutdown of the reactor, because the annex of the reactor building was submerged by the tsunami, the emergency power supplies (M/C 1C and 1HPCS) became disabled. Moreover, because the sea water heat exchanger building was flooded by the tsunami, the emergency power supplies (P/C 1C-2 and 1D-2) became disabled.

At that time, the power supply was cut off from MCC 1C-1-8 because the emergency power supply (M/C 1C) was disabled, thereby shutting down the AC120V station vital panel board 1A, thus causing disability to some recorders in the MCR.

In addition, all the emergency DG systems (systems A, B and HPCS) were in usable conditions immediately after the automatic shutdown of the reactor. However, after being flooded by the tsunami, all emergency machinery cooling system pumps became unactivatable. Furthermore, because the annex of the reactor building was also flooded by the tsunami, the DG main unit and its accessory equipment (including pumps, a control panel and MCC) were also flooded, thus disabling all the DG units.

During the subsequent restoration the AC120V station vital panel board 1A was restored to a usable state by receiving electricity from the cable temporarily installed on the temporary supply panel board of Unit 2 (conducted on March 12). Furthermore, with regard to the disabled emergency power supply (P/C 1D-2), the RHRC pump (D) and the RHRS pump (B), all of which were required for cooling the reactor and the SFP, received electricity from the power supply (P/C 1WB-1) of the radioactive waste treatment building via the temporarily installed cable. As well, the EECW pump (B) received electricity from a high voltage power supply vehicle (conducted on March 13 and 14).

Subsequently, the temporary power supply for the EECW pump (B) was switched from the high voltage power supply vehicle to the emergency power supply (P/C 1D-1) (switched on March 30). In addition, expecting to lose the external power supply system, the procedures to receive electricity from the emergency power supplies of Reactors 2 and 3 (M/C 2D and M/C 3D, respectively) were devised as a standby power supply system for the DG (B) of the usable emergency power supply (M/C 1D) (conducted on April 21).

In addition, even if the external power supply systems failed, the emergency power supplies (M/C 2D and 3D) can receive electricity from DGs (B) of Reactors 2 and 3 because they are in usable condition.

Moreover, Unit 1's DG (B) was also restored on July 15. Thus all the emergency power supplies required for the reactor and the SFP have been secured.

**Table Appendix 1-1 Fukushima Daini Nuclear Power Station Reactor Unit 1 Situation in Chronological Order After the Occurrence of the Earthquake**

Friday, March 11, 2011

- 14:46 Earthquake occurs.
- 14:48 The reactor automatically shuts down. (The alarm goes off detecting the state of “earthquake-accelerated large trip”.) All control rods are fully inserted.
- 14:48 One of Tomioka circuits shuts down (number 2 trips, the system continues to receive electricity from number 1).
- 15:00 The subcriticality of the reactor is confirmed.
- 15:22 The first tsunami wave is confirmed. (Since then the tsunami has been continuously confirmed until 17:14 p.m.)
- 15:33 The CWP (C) is manually shut down.
- 15:34 DGs (A), (B) and (H) are automatically activated. Immediately after the activation, they shut down due to the tsunami.
- 15:36 The MSIV is fully closed manually.
- 15:36 The RCIC system is manually activated (Subsequently, the system starts and stops randomly.)
- 15:50 All Iwaido circuits shut down.  
(Number 2 shuts down. Number 1 was not operated before the occurrence of the earthquake due to inspection.)
- 15:55 The reactor depressurization is initiated (the SRV automatically opens). (Subsequently, reactor pressure is controlled through automatic and manual switches.)
- 15:57 The CWPs (A) and (B) automatically shut down.
- 17:35 The alarm goes off detecting the state of “D/W pressure high.” There is an entry describing the state of “MSIV reactor water level low (L-2)” in the alarm typer at 15:37 p.m. of the same day. Based on these facts, one cannot deny the possibility that the cause of the pressure increase could be a leakage of reactor coolant in the PCV. It is therefore determined that the specified events (leakage of reactor coolant) stipulated in Article 10, Clause 1 of the Special Law for Nuclear Emergency has occurred. (As a result of the inspection on the relevant parameters subsequently conducted, no reactor coolant leakage is observed. Therefore, at around 18:33 p.m. on the same day, it is determined that the situation does not fall under the above event.)
- 17:53 The D/W cooling system is manually activated.
- 18:33 Based on the fact that the activation of the sea water pump that has the function to remove heat from a reactor cannot be confirmed, it is determined that the specified event (loss of the function to remove heat from a reactor) stipulated in Article 10, Clause 1 of the Special Law for Nuclear Emergency has occurred.

Saturday, March 12, 2011

- 00:00 MUWC alternative water pouring is initiated.
- 03:50 Rapid depressurization of the reactor is initiated.  
(This is because the situation has turned into the operation prohibition status.)
- 04:56 Rapid depressurization of the reactor is complete.

- 04:58 The RCIC is manually shut down (operation prohibition due to the reactor pressure decrease).
- 05:22 Because the S/C temperature has exceeded 100°C, it is determined that the specified event (loss of the pressure suppression function) stipulated in Article 15, Clause 1 of the Special Law for Nuclear Emergency has occurred.
- 05:58 The alarm goes off detecting the abnormality in control rod 10—51 PIP
- 06:20 The S/C cooling operation using the FCS coolant (MUWC) is conducted.
- 07:10 The D/W spraying operation using MUWC is conducted. (From this point forward, it has been conducted according to the situation.)
- 07:37 The S/C spraying operation using MUWC is conducted. (From this point forward, it has been conducted according to the situation.)
- 07:45 The S/C cooling operation using the FCS coolant (MUWC) is terminated.
- 10:21 Creation of the PCV pressure-resistant vent line is initiated.
- 10:30 The alarm for the abnormality in control rod 10—51 PIP is cleared. (Subsequently, it repeatedly goes off and becomes cleared several times.)  
Around 13:38 One of Iwaido circuits begins receiving electricity. (The restoration of Number 2 has been completed.)
- 18:30 Creation of the PCV pressure-resistant vent line is complete.

Sunday, March 13, 2011

- 05:15 (appx.) Two Iwaido circuits begin receiving electricity (The restration of Number 1 has been completed.)
- 20:17 The RHRS pump (B) is manually activated. (Electricity is received from P/C 1WB-1 through the temporarily installed cable.)
- 21:03 The RHRC pump (D) is manually activated. (Motor replacement/receiving electricity from P/C 1WB-1 through the temporarily installed cable.)

Monday, March 14, 2011

- 01:24 Due to the manual activation of the RHR (B) pump (the initiation of the S/C cooling mode) and the activation of the RHR (B) pump, it is determined that the specified event (loss of the function to remove heat from a reactor) stipulated in Article 10, Clause 1 of the Special Law for Nuclear Emergency has occurred.
- 01:44 The EECW (B) is manually activated. (motor replacement/receiving electricity from the high voltage power supply vehicle)
- 03:39 The RHR (B) S/C spray mode is initiated.
- 10:05 The water pouring operation is conducted under the RHR (B) LPCI mode.
- 10:15 Because the S/C water temperature has dropped to lower than 100°C, it is determined that it has recovered from the specified event (loss of the pressure suppression function) stipulated in Article 15, Clause 1 of the Special Law for Nuclear Emergency.
- 16:30 The water pouring operation through the FPMUW system is initiated to cool down the SFP.

- 17:00 Because the reactor temperature has dropped to lower than 100°C, the reactor cooling operation is terminated.
- 20:26 Circulation operation of the FPC (B) is initiated.
- 22:07 Because the radiation level that exceeds 5μGy/h is measured at the MP (No. 1), it is determined that the specified event (increase in the site boundary radiation dose) has occurred. (It can be surmised that the increase in the radiation dose was caused by radioactive substances discharged into the atmosphere upon the occurrence of the accident at Fukushima Daiichi.)

Tuesday, March 15, 2011

- 00:12 Because the radiation level that exceeds 5μGy/h is measured at the MP (No. 3), it is determined that the specified event (increase in the site boundary radiation dose) has occurred. (It can be surmised that the increase in the radiation dose was caused by radioactive substances discharged into the atmosphere upon accident at Fukushima Daiichi.)

Wednesday, March 16, 2011

- 00:42 The RHR (B) SFP cooling operation is initiated.
- 10:30 The SFP water temperature of approximately 38°C is confirmed. (It returned to the temperature before the occurrence of the earthquake.)

### **(3) Unit 2**

#### **a. Station behavior upon occurrence of the earthquake**

The reactor was running at normal rated heat output when an earthquake centered in Sanriku-coast occurred at 14:46, March 11, 2011. The reactor automatically shut down its operation at 14:48 with a “large earthquake acceleration trip” alert. Immediately thereafter, full-insertion of all control rods (CR) and the reactor’s subcriticality were confirmed. It was also confirmed that equipment necessary for the reactor’s cold shutdown and cooling of SFP were in a sound and stable condition.

However, due to the tsunami after the earthquake (1<sup>st</sup> wave of the tsunami was visually confirmed at 15:22, on the same day), these equipment for cold shutdown and SFP cooling became disabled because of water intrusion, etc. Also, S/C cooling was not possible due to loss of the reactor heat removal function, and S/C water temperature gradually rose up to over 100°C.

Later, to enable a part of the equipment for reactor cold shutdown and SEP cooling, inspection and repair of submerged equipment were conducted. Also, power supply was obtained from a temporary power source. After recovery of the reactor’s heat removal function, S/C cooling was performed, and the S/C water temperature fell below 100°C. Thereafter, by RHR1 system, the reactor maintained its cold shutdown temperature below 100°C until 18:00, March 14. At the same time, SFP had been continuously cooled down, and the station had maintained its stable condition.

#### **b. State of the “shut down” function**

The earthquake triggered a “large earthquake acceleration trip” alert at 14:48 (operational set point in vertical direction in reactor building underground 2<sup>nd</sup> floor: 100 gal), which immediately led to full-insertion of all control rods. The reactor automatically shut down as designed and became subcritical at 15:01.

#### **c. State of the “cooling” function**

Shortly after automatic shutdown of the reactor, a void (coefficient) in the core of the reactor decreased due to the sharp decline of the reactor output. The water level of the reactor dropped down to “reactor vessel low water level (L3).” After that, with the water supply from the reactor’s feedwater system, the water level was recovered and did not drop to the point at which the ECCS pump and RCIC would automatically start.

At 15:34, March 11, Main Steam Isolation Valve (MSIV) was fully closed manually, and the reactor’s pressure control was implemented by SRV. This measure was taken to prepare for the situation where the condenser fails to condense main steam, following CWP shutdown due to the Tsunami, and in the case of losing turbine ground seal steam, following shutdown of the auxiliary boiler due to impact of the earthquake.

With MSIV fully-opened, RCIC was manually activated at 15:43, and water injection into the reactor was conducted. After RCIC’s automatic shutdown at 15:46 by “reactor vessel low water level (L8)”, the reactor’s water level was adjusted by manual start-up and automatic shutdown of RCIC.

Based on indication of the operation/ shut off lamp displays and the fact that sea water heat exchanger was flooded by the tsunami, it was determined that RHRC pump (A,B,C,D), RHRS pump (A, B, C, D), EECW pump (A,B) and HPCSC pump could not be started (it was confirmed later at the station that pumps were inoperable due to water exposure on a part of the monitors and emergency power

source (P/C 2C-2, 2D-2). Thus, all ECCS pumps became unusable, and the function of removing residual heat from the reactor was lost.

Initially, water injection into the reactor was performed by RCIC. However, with opening of SRV, reactor pressure lowered. Accordingly, at 4:50, March 12, water injection by MUWC was started based on operation procedure manual which was implemented as a severe accident countermeasure. RCIC automatically shut down at 4:53, on the same day, due to lower steam pressure for the RCIC turbine caused by depressurization of the reactor. Subsequently, the reactor's water level was adjusted by alternative water injection with MUWC.

With operation of RCIC and opening of SRV, temperature and pressure inside PCV increased. However, as cooling with RHR pump (A,B) was not possible, an alarm signal was triggered at 18:50 on March 11, indicating "high D/W pressure" (design value: 13.7kPa [gage]).

As a result, all ECCS pump's auto-start signals were issued. However, as RHRC pump (A,B,C,D), RHRS pump (A,B,C,D), EECW pump (A,B) and HPCSC pump were disabled, manual shutdown was conducted after startup. After this, the auto-start prevention measure (hold pull of control switch) was implemented.

Later on at 5:32 on March 12, S/C water temperature rose over 100°C. The temperature rose up to approximately 139°C at 7:00 a.m. on March 14.

To cool down S/C, from 6:30, March 12, MUWP, which is cooling water, was injected into S/C using the cooling water drain line from FCS's cooler to S/C. Alternative injection into the reactor by MUWC was changed into D/W spray from 7:11, and changed into S/W spray from 7:35 as necessary to perform alternative cooling of PCV.

Inspection and repair of RHRC pump (B), RHRS pump (B) and EECW pump (B) were conducted along with alternative injection into the reactor by MUWC, PCV alternative cooling and S/C cooling by FCS cooling water (MUWP). The sea water heat exchanger building and emergency power supply unit (P/C 2C-2, 2D-2) were submerged in water. Therefore, temporary cables obtained offsite were used to feed emergency power. Power was supplied from the radioactive waste treatment building (P/C 1WB-1) receiving power from the external power system. Power was also received from No.3 heat exchanger building emergency power (P/C3D-2) by installation of temporary cables. By reception of this power, RHRC pump (B), RHRS pump (B) and EECW pump (B) recovered their function and started sequentially from 3:20 on March 14.

Later on, RHR pump (B) was started from 7:13, March 14. Also, S/C cooling performed by RHR pump (B) resulted in gradual decline in water temperature. As of 15:52, S/C water temperature fell below 100°C.

To promptly cool down the reactor water as well as S/C water, an implementing procedure manual was created using a previously formulated accident operation manual as reference. From 10:48 on the same day, S/C water was injected into the reactor by RHR pump (B) via LPCI line. At the same time, the reactor water was flowed into S/C via SRV, and the S/C water was cooled by RHR heat exchanger (B) to re-inject into the reactor via LPCI line again. Such circulation line (S/C → RHR pump (B) → RHR heat exchanger (B) → LPCI line → Reactor → SRV → S/C) was implemented as an emergency cooling measure. It was confirmed that this measure cooled down the reactor temperature to below 100°C at 18:00, the same day.

The above indicates that despite a temporary loss of the reactor's cooling function, water injection into the reactor was continued. Later sampling of the

reactor water showed that iodine 131 was below detection limit. Thus, no fuel damage was incurred.

**d. State of the “trapping” function**

With “reactor vessel low water level (L3)” alert triggered at the reactor’s automatic shutdown, PCIS and SGTS operated normally, and PCV was isolated, and reactor building subatmospheric pressure was maintained. PCV pressure increased up to approximately 279kPa [gage], but it did not reach the maximum operating pressure of 310kPa [gage].

It was confirmed that there was no abnormal change in stack radiation monitor or MP values, or radiation impacts to outside.

Assuming PCV pressure’s tendency to increase and the long recovery time for the reactor’s heat removal function, a line configuration for PCV pressure vent was implemented (one action remained for an operation to open the outlet valve on S/C).

**e. State of the spent fuel pool cooling system**

As for the equipment necessary for cooling of SFP, FPC had maintained SFP water temperature at about 32.5°C and water level higher than the level of overflow water prior to the earthquake. Due to the impact of the earthquake, FPC pump tripped (“low water level of skimmer surge tank” or “low pump pressure”). The tsunami flooded SW pump (A,B,C) in non-safety service water system near the outside water intake. RCW pump on the ground floor of the sea water heat exchanger building was also under water and unusable. For these reasons, cooling water was not supplied to the FPC heat exchanger, and SFP cooling by FPC was not possible.

This raised SFP water temperature up to about 56°C, but cooling of SFP by RHP pump (B) was started from 1:28 on March 16, and by 10:30, the temperature was down to about 32.5°C, the same level as that before the earthquake.

The above indicates that while cooling function was also temporarily lost on SFP, operational limits (SFP water level; near the level of overflow. Water temperature; 65°C or lower) specified under Safety Preservation Rules of Nuclear Facilities were met.

**f. State of the “power supply” function**

Immediately after automatic shutdown of the reactor, the facility’s power system was usable. However, as the sea water heat exchanger building was submerged due to the tsunami, the emergency power source (P/C 2C-2 and 2D-2) became unusable.

Emergency DGs were all usable right after the reactor’s automatic shutdown, but after the Tsunami reached the facility, it was not possible to start RHRS pump (A,B,C,D), EECW pump (A,B) and HPCSC. As a result, all emergency DGs became unusable.

Through the recovery afterwards, out of the power loads of disabled emergency power (P/C 2D-2), the following secured power by temporary cable installation (performed on March 14): Power for RHRC pump (B) and RHRS pump (B) necessary for cooling the reactor and SFP was supplied from the power source (P/C 1WB-1) of the radioactive waste treatment building. EECW pump (B) received power from the emergency power source (P/C 1WB-1) of the No.3 heat exchanger building.

As the above measure enabled use of RHRC pump (B), RHRS pump (B) and

EECW pump (B), emergency power (M/C 2D) became available via DG (B) even if external power source was lost. From April 2, DG (HPCS) became usable, thus emergency power source for cooling of the reactor and SFP has been secured.

**Table Appendix 1-2 Fukushima Daini Nuclear Power Station Reactor Unit 2  
Situation in Chronological Order After the Occurrence of the  
Earthquake**

Friday, March, 11, 2011

- 14:46 Earthquake occurred
- 14:48 Automatic shutdown of reactor ("large earthquake acceleration trip" alert was triggered and all control rods were fully inserted.)
- 14:48 Tomioka line No. 1 shutdown (No. 2 was tripped, power continued to be received from No. 1.)
- 15:01 Reactor's subcritical status confirmed
- 15:22 The first tsunami wave was confirmed (thereafter, tsunami waves were confirmed intermittently until 17:14)
- 15:34 DG (H) automatically started/immediately thereafter it shut down due to tsunami impact
- 15:34 MSIV fully closed manually
- 15:35 RHR (B) manually started (shut down at 15:38)
- 15:35 CWP (C) manually shut down, CWP (A) (B) automatically shut down
- 15:41 DG (A) (B) automatically started/thereafter shut down due to tsunami impact
- 15:41 Depressurization of the reactor commenced (SRV automatically opened) (thereafter, valve was repeatedly opened and closed to control reactor pressure)
- 15:43 RCIC manually started (thereafter, starts-stops occurred as the circumstances demand)
- 15:50 Iwaido line fully shut down (No. 2 shutdown, No.1 had been shut down for checkup before earthquake)
- 18:33 Because startup of a sea water pump for equipment having capability to remove heat from the reactor could not be confirmed, it was determined that an event specified under Article 10, Clause 1 of Special Law for Nuclear Emergency had occurred (loss of reactor heat removal capability).
- 18:50 "High D/W pressure" alert was issued.
- 20:02 Drywall cooling system manually startup

Saturday, March 12, 2011

- 04:50 Alternative water injection started using the make-up water condensate system (MUWC)
- 04:53 RCIC automatically shut down (due to lower reactor pressure)
- 05:32 Because S/C temperature had risen above 100°C, it was determined that an event specified under Article 15, Clause 1 of Special Law for Nuclear Emergency had taken place (loss of pressure suppression capability)
- 06:30 S/C cooling implemented using coolant (MUWP) from flammable control system (FCS).
- 07:11 D/W spraying implemented using MUWC (thereafter implemented as circumstances demanded)
- 07:35 S/C spraying implemented using MUWC (thereafter implemented as circumstances demanded)
- 07:52 S/C cooling using FCS coolant (MUWP) shut down
- 10:33 Configuration of PCV hardened venting line commenced

10:58 Configuration of PCV hardened venting line completed  
13:38 (appx.) Power received from Iwaido line No.1 (No.2 restored)

Sunday, March 13, 2011

5:15 (appx.) Power received from Iwaid line No.2 (No.1 restored)

Monday, March 14 2011

03:20 EECW (B) manually started up  
(Power received from P/C 3D-2 via temporary cable)  
03:51 RHRS (B) manually started up  
(Power received from P/C 1WB-1 via temporary cable)  
05:52 RHRC (B) manually started up  
(Power received from P/C 1WB-1 via temporary cable)  
07:13 RHR (B) manually started up (S/C cooling mode commenced)  
With startup of RHR (B), it was determined to cancel the occurrence of a special event (loss of capability to remove heat from reactor) under the provision of Article 10, Clause 1 of Special Law for Nuclear Emergency.  
07:50 RHR (B) S/C spraying mode commenced  
10:48 Coolant injection into reactor was started in RHR (B) low pressure coolant injection (LPCI) mode  
15:52 Because S/C temperature had fallen below 100°C, it was determined that the station recovered from the event specified under Article 15, Clause 1 of Special Law for Nuclear Emergency (loss of pressure suppression capability)  
18:00 Reactor temperature had fallen below 100°C, and cold shutdown of reactor achieved.  
22:07 As radiation dose measured exceeded 5μGy/h at MP (No.1), it was determined that a special event (increase in radiation dose in site boundary) under the provision of Article 10, Clause 1 of Special Law for Nuclear Emergency took place (the cause of the dose increase is surmised to be due to the effects of radioactive material released into the atmosphere, following the accident at Fukushima Daiichi Nuclear Power Station).

Tuesday, March 15, 2011

0:12 As radiation dose measured exceeded 5μGy/h at MP (No.3), it was determined that a special event (increase in radiation dose in site boundary) under the provision of Article 10, Clause 1 of Special Law for Nuclear Emergency took place (the cause of the dose increase is surmised to be due to the effects of radioactive material released into the atmosphere, following the accident at Fukushima Daiichi Nuclear Power Station).

Wednesday, March 16, 2011

01:28 RHR (B) commenced cooling of SFP  
10:30 SFP water temperature was confirmed to be about 32.5°C  
(recovered to the temperature before earthquake)

#### **(4) Unit 3**

##### **a. Station behavior upon occurrence of the earthquake**

The station was in operation at a constant rate thermal power when the earthquake occurred at 14:46, March 11, 2011. The earthquake's epi-center was offshore of Sanriku. At 14:48 on the same day, the reactor shut down due to "large earthquake acceleration trip" alert. Immediately thereafter, all control rods were fully inserted, and the reactor's subcriticality was confirmed. It was also confirmed that equipment necessary for the reactor's cold shutdown and cooling of SFP were steadily operating in sound condition.

While equipment for the reactor's cold shutdown and cooling of SFP became partially disabled, cooling of the reactor was implemented from March 12, using RHR1 system which was operatable without impacts of the tsunami. Cold shutdown of the reactor was confirmed on the same day.

##### **b. State of the "shut down" function**

Due to the earthquake, "large earthquake acceleration trip" alert (reactor building underground 2<sup>nd</sup> floor, operational set point value in horizontal direction: 135 gal) was issued at 14:48. Immediately thereafter, all control rods were fully inserted. The reactor automatically shut down as designed, and it was in subcritical state at 15:05 on the same day.

##### **c. State of the "cooling" function**

Immediately after the reactor's automatic shutdown, void in the reactor core decreased, following drastic decline of reactor output. Water level of the reactor decreased to "reactor vessel low water level (L3)." With water supply from the reactor's feedwater system, the water level of the reactor was later recovered and did not drop to the point at which the ECCS pump and RCIC would automatically start. On March 11, at 15:37, Main Steam Isolation Valve (MSIV) was fully closed manually, and the reactor's pressure control was implemented by SRV. This measure was taken to prepare for the situation where the condenser fails to condense main steam, following CWP shutdown due to the Tsunami, and loss of turbine ground seal steam, following shutdown of auxiliary boiler due to earthquake impact.

With full opening of MSIV, Reactor Core Isolation System (RCIC) was manually started at 16:06 on the same day, and water was injected into the reactor.

Due to the fact that the sea water heat exchanger building was flooded by the tsunami along with indication by operation on/off lamp, it was determined that RHRC pump (A,C), RHRS pump (A,C) and EECW pump (A) could not be started (it was confirmed later at the station site that these pumps were not usable because the motors and emergency power source were partially flooded). For this reason, it was not possible to start LPCS pump and RHR pump (A).

As for the emergency power source (P/C 3D-2) and its load, RHRC pump (BD), RHRS pump (B,D) and EECW pump (B) as well as HPCSC pump and HPCSS pump, the amount of sea water exposure to the sea water heat exchanger building was smaller compared with other pumps. Based on this reason, these pumps were presumed to be usable as there was little impact on this equipment.

Also, RHR pump (B,C) and HPCS pump were usable because there was no water intrusion in the 2<sup>nd</sup> underground floor of the reactor ward of reactor building.

Water injection into the reactor was initially performed by Reactor Core Isolation Cooling System (RCIC). However, from 22:53, March 11, alternative water injection by MUWC introduced as a severe accident countermeasure, was also

implemented. Later, lower reactor pressure due to SRV opening reduced steam pressure for RCIC turbine operation. This led to manual shutdown of RCIC at 23:11 on the same day. Thereafter, alternative water injection using MUWC had been performed. However, at 00:06, on the same day, water injection and cooling was implemented by the usable RHR pump (B). At 12:15, March 12, the reactor's water temperature fell below 100°C, and its cold shutdown was confirmed.

At 19:46, March 11, "high D/W pressure (design value: 13.7kPa [gage]) alert was issued due to temperature and pressure rise inside PCV, following RCIC operation and SRV opening. This was followed by the automatic start-up signal for all ECCS pumps. However, HPCS pump, LPCS pump and RHR pump(A,C) were not automatically started because the automatic start prevention measure was in place (hold pulling control switch) due to the disabled cooling system (RHRC (A, C), RHRS (A,C) and EECW(A)). RHR pump (B) was in operation for cooling of S/C at "high D/Wpressure" alert (started at 15:36, March 11).

Based on the above, it is found that fuel was not damaged as the reactor's cooling function was maintained. Later sampling of the reactor water confirmed that iodine 131 was below detection limits.

**d. State of the "trapping" function**

With "reactor vessel low water level (L3)" alert issued at automatic shutdown of the reactor, Primary Containment Isolation System (PCIS) and Stand-By Gas Treatment System (SGTS) were in normal operation, and PVC isolation and maintenance of the reactor's subatmospheric pressure were conducted. PCV pressure rose up to about 38kPa [gage] at D/W, but it did not reach PCV's maximum operating pressure, 310kPa [gage].

Also, it was confirmed that there was no abnormal change in stack radiation monitor and MP values, or radiation impact to the outside.

In case of rising PCV pressure, line configuration of PCV hardened venting line was implemented (one action remained for an operation to open the outlet valve on the S/C).

**e. State of the spent fuel pool cooling system**

The following describes the condition of equipment necessary for cooling of Spent Fuel Pit (SFP). Before the earthquake, Fuel Pool Cooling & Filtering System (FPC) had maintained SFP's water level above overflow level and kept SFP's water temperature about 34°C. Yet, with the impact of the earthquake, FPC pump tripped ("low water level of skimmer surge" tank or "low pump pressure"). At the same time, due to the Tsunami impact, SW pump (A, B, C) in non-safety service water system placed near water intake outside was flooded and became unusable. Also, RCW pumps (A, B, C) in the ground floor of the sea water heat exchanger building were submerged and disabled. For these reasons, cooling water was not supplied to the FPC heat exchanger, thereby disabling SFP cooling by FPC.

These events raised SFP water temperature up to about 51°C. However, from 17:42, March 15, cooling water of FPC heat exchanger was switched from RCW to RHRC. By this measure, SFP cooling by FPC was implemented. At 22:30, March 16, SFP's water temperature was restored back to about 34.0°C, the same level prior to the earthquake.

Based on the above, it was found that while SFP suffered temporary loss of cooling capability, it met operational limits (SFP water level: about overflow level, water temperature; below 65°C) specified under the Safety Preservation Rules of

Nuclear Facilities.

**f. State of the “power supply” function**

Immediately after the reactor’s automatic shutdown, all power systems in the facility were usable. However, as the sea water heat exchanger building was flooded by the tsunami, emergency power (P/C 3C-2) became unusable.

Also, emergency diesel generators (DG) were all (A system, B system and HPCS system) usable right after reactor’s automatic shutdown. However, after the tsunami reached the facility, it was not possible to start RHRS (A,C) pump and EECW (A) pump. As a result, DG (A) became unusable.

Since DG (B) and DG (HPCS) were usable, emergency power (M/C 3D and 3HPCS) were receivable by DG (B, HPCS) even in case of losing external power supply.

Based on the above, it is found that emergency power necessary for cooling of the reactor and SFP were secured.

**Table Appendix 1-3 Fukushima Daini Nuclear Power Station Reactor Unit 3  
Situation in Chronological Order After the Occurrence of the  
Earthquake**

Friday, March 11, 2011

- 14:46 Earthquake occurred
- 14:48 Automatic shutdown of the reactor ("large earthquake acceleration trip" alert was issued), and all control rods were fully inserted
- 14:48 Tomioka line No.1 shutdown (NO. 2 tripped, power continued to be received by No. 1)
- 15:05 Reactor's subcriticality confirmed
- 15:22 The first wave of tsunami was confirmed (thereafter, tsunami waves were confirmed intermittently until 17:14)
- 15:34 CWP (C) Manual shutdown
- 15:35 DG (A) (B) (H) automatic startup/Immediately after that DG (A) shutdown due to tsunami impact
- 15:36 RHR (B) Manual startup (S/C cooling mode commenced)
- 15:37 MSIV fully closed manually
- 15:38 CWP (B) Manual shutdown
- 15:46 Depressurization of the reactor commenced (SRV automatically opened) (thereafter, valve was repeatedly opened and closed to control reactor pressure)
- 15:50 Iwaido line fully shutdown (No.2 shutdown, No. 1 had been shut down for checkup before the earthquake)
- 16:06 RCIC manually started (thereafter, starts-stops occurred as the circumstances demand)
- 16:48 CWP (A) Manual shutdown
- 19:46 "High D/W pressure" alert was issued (RHR (B) automatically switched from S/C cooling mode to LPCI mode)
- 20:07 RHR (B) Switched from LPCI mode to S/C cooling mode
- 20:12 D/W cooling system manually started
- 22:53 Alternative water injection using MUWC commenced
- 23:11 RCIC manual shutdown (due to lower reactor pressure)

Saturday, March 12, 2011

- 00:06 RHR (B) Commenced preparation for SHC mode configuration
- 01:23 RHR (B) manual shutdown (to prepare for SHC mode)
- 02:39 RHR (B) Manual startup (S/C cooling mode commenced)
- 02:41 RHR (B) S/C spraying mode commenced
- 07:59 RHR (B) Manual shutdown (S/C cooling mode and S/C spraying mode shutdown)
- 09:37 RHR (B) Manual startup (SHC mode operation commenced)
- 12:08 Configuration of PCV hardened venting line commenced
- 12:13 Configuration of PCV hardened venting line completed
- 12:15 Water temperature of the reactor fell below 100°C, and reactor cold shutdown achieved
- 13:38 (appx.) Power received by Iwaido line No.1 (No. 2 restored)

Sunday, March 13, 2011

- 05:15 (appx.) Power received by Iwaido line No. 2 (NO. 1 restored)

Monday, March 14, 2011

22:07 As radiation dose exceeded 5 $\mu$ Gy/h at MP (No. 1), it was determined that a special event (increase in radiation dose in site boundary) under the provision of Article 10, Clause 1 of Special Law for Nuclear Emergency took place (the cause of the dose increase is surmised to be due to the effects of radioactive material released into the atmosphere, following the accident at Fukushima Daiichi Nuclear Power Station).

Tuesday, March 15, 2011

00:12 As radiation dose exceeded 5 $\mu$ Gy/h at MP (No. 3), it was determined that a special event (increase in radiation dose in site boundary) under the provision of Article 10, Clause 1 of Special Law for Nuclear Emergency took place (the cause of the dose increase is surmised to be due to the effects of radioactive material released into the atmosphere, following the accident at Fukushima Daiichi Nuclear Power Station).

17:42 FPC heat exchanger cooling water was switched (RCW  $\rightarrow$  RHRC)

Wednesday, March 16, 2011

22:30 SFP water temperature was confirmed to be about 34 $^{\circ}$ C (recovered to the temperature before the earthquake)

## **(5) Unit 4**

### **a. Station behavior upon occurrence of the earthquake**

During the constant thermal output rated operation, due to the earthquake occurred at 14:46 on 11 March 2011 with epicenter off the coast of Sanriku region the reactor automatically shut down by "trip due to high seismic acceleration" at 14:48 on the same day. Right after the event, ensuring that all control rods were fully inserted and the reactor was subcritical, all facilities necessary for cold shutdown of the reactor and SFP cooling were confirmed integrity and in stable condition.

However, because of the tsunami after the quake (the first wave was observed to reach at 15:22 on the same day) the facilities necessary for cold shutdown and SFP cooling were submerged in water and unavailable.

In addition, S/C cooling was unavailable due to the loss of heat removal function of the reactor, and then the S/C water temperature gradually rose and exceeded 100°C.

After those events, in order to recover part of the facilities for cold shutdown and SFP cooling, the submerged facilities were checked and repaired, and power supply from the temporary source was started. By cooling S/C after the recovery of heat removal function of the reactor, the S/C water temperature dropped under 100°C. From that time on, by using RHR1 system the water, temperature of the reactor was lowered to less than 100°C and kept in cold shutdown state by 7:15 on 15 March, SFP has been continuously cooled down, and the station is currently kept stable.

### **b. State of the "shut down" function**

The earthquake caused "high seismic acceleration trip" (on the second floor of the reactor building, the horizontal trip value setting: 150 Gal) to be issued at 14:48, and then all of the control rods were fully inserted immediately.

The reactor automatically shut down as designed, and it became subcritical at 15:05 on the same day.

A drift alarm on control rod 10-19 was issued at 12:43 on 13 March, which was cleared at 20:19 on 14 March but was issued again at 21:07 on 14 March. Control rod position was readable both with the indicator of "fully inserted" and the display of position. When the alarm was issued, the control rod status was presented as "fully inserted" with the indicator lit while the position display was unlit.

When the alarm was issued, no significant change was observed in SRNM indication and the reactor remained subcritical. The control rod status was presented as fully inserted. The drift alarm was continuously issued, and in order to stop it the countermeasure was taken by isolating the control rod (valve out) at 16:56 on 15 March. From that time on, no significant change has been observed in SRNM and the reactor remains subcritical.

### **c. State of "cooling" function**

Just after the reactor automatically shut down, the reactor water level dropped to "reactor vessel low water level (L-3)" as voids inside the core decreased due to the steep drop of reactor output. Later, the reactor water level recovered by supply from the reactor feedwater system without dropping to the level to automatically start ECCS pump and RCIC.

For the possibility of stop of CWP and subsequent outage of main steam condensation by the condenser due to damage from tsunami, and for the

possibility of loss of steam in the turbine gland seal caused by stop of auxiliary boiler due to the quake, MSIV was fully closed by manual operation at 15:36 on 11 March to control the pressure of the reactor by SRV.

Along with full close of MSIV, RCIC was manually started at 15:54 on the same day to inject water to the reactor. And then, after the automatic stop of RCIC due to "reactor vessel high water level (L-8)" at 16:11 on the same day, the reactor water level was controlled by manual start and automatic stop of RCIC.

Judging from the fact that the seawater heat exchanger was submerged in water due to the tsunami and from the lamps to indicate operating/halt, RHRC pumps (A, B, C, D), RHRS pumps (A, B, C, D) and EECW pumps (A, B) were estimated as inoperable (some of the motors and power supplies (P/C 4C-2, 4D-2) were confirmed at the site on the later day that they were inoperable because of submersion). Under that situation, LPCS pumps and RHR pumps (A, B, C) were inoperable, and therefore the function to remove the residual heat of the reactor was lost.

HPCSC pumps and HPCSS pumps were estimated that they were available because of less damage from water submersion as there was less amount of seawater submersion in the pump area inside the seawater heat exchanger building in comparison to other pumps. In addition, as there was no inundation on the second basement floor of the reactor building, HPCS pumps were in operable condition.

Injection of water to the reactor was initially done by RCIC, but because the steam pressure to drive RCIC turbine decreased due to the reactor pressure drop caused by opened SRV, after the automatic stop of RCIC at 0:16 on 12 March, alternative water injection was started according to the operation manual by MUWC which was installed as a countermeasure to severe accidents. From that time on, the reactor water level was adjusted by start/stop of HPCS pumps which were operable without damage from the tsunami.

The temperature and pressure inside PCV increased along with the operation of RCIC and opening of SRV. Because the cooling by RHR pumps (A, B) was not available, "high D/W pressure" (setting: 13.7kPa [gage]) was issued on 19:02 on 11 March.

The signal to automatically start all of the ECCS pumps was generated along with that alarm, but the water injection to the reactor was done by RCIC and the automatic start was prevented (the control switch was pulled and hold) because the cooling system (RHRC, RHRS and EECW) were not operable, each ECCS pump was not automatically started.

After those events, S/C water temperature exceeded 100°C at 6:07 on 12 March. The S/C water temperature has reached the maximum of 137°C (12:30 on 14 March).

In order to cool down S/C, the injection of cooling water (MUWP) to S/C was started at 7:23 on 12 March by use of cooling water drain lines from FCS cooler to S/C, and in addition to that, the alternative cooling of PCV was performed at 7:35 by switchover to S/C spray from alternative water injection by MUWC.

In parallel with the alternative water injection to the reactor by MUWC, the alternative cooling of PCV and the cooling of S/C by FCS cooling water (MUWP), RHRC pump (B), RHRS pump (D) and EECW pump (B) (the motor was replaced for RHRC pump (B)) were checked and repaired. Because the seawater heat exchanger building was submerged in water and its emergency power supplies (PC 4C-2, 4D-2) were inundated, high voltage power supply vehicles and temporary power cords were emergently prepared from outside the site and used.

By installing temporary power cords and providing power from the emergency power supply (P/C3D-2) of the heat exchanger building of reactor 3 whose power was supplied from the electric system outside and by providing power from the high voltage power supply vehicles, RHRC pump (B), RHRS pump (D) and EECW pump (B) were recovered to operable conditions, and then they were started one by one from 11:00 on 14 March.

After that, RHR pump (B) was started on 15:42 on 14 March.

As a result of S/C cooling by RHR pump (B), the S/C water temperature started gradually dropping and fell under 100°C at 07:15 on 15 March.

Furthermore, in order to quickly cool down the reactor water in addition to the cooling of S/C water, the implementation procedure was improvised by referencing the predefined emergency operation manual. Along with the start of S/C water injection to the reactor by RHR pump (B) from LPCI line at 18:58 on the same day, the emergency cooling procedure with the circulating line was performed by flowing the reactor water into S/C via SRV, cooling S/C water by RHR heat exchanger (B), and injecting the water to the reactor from LPCI line again (S/C → RHR pump (B) → RHR heat exchanger (B) → LPCI line → the reactor → SRV → S/C). With this configuration the reactor water temperature dropped under 100°C and the reactor was confirmed in cold shutdown state at 7:15 on 15 March.

The mentioned above suggests that the water injection to the reactor was successfully continued although the cooling functions of the reactor was temporarily lost, and no fuel damage occurred because the level of iodine-131 was found lower than detection limit in the reactor water sampled in a later investigation.

#### **d. State of the “trapping” function**

In accordance with the issuance of "reactor vessel low water level (L-3)" on the automatic shutdown of the reactor, PCIS and SGTS operated correctly to isolate PCV and maintain the negative pressure of the reactor building. The pressure of PCV has reached the maximum value of about 245kPa [gage] (S/C side), but not reached its maximum operating pressure of 310kPa [gage].

No unusual changes in the stack radiation monitor or MP values were observed and no outside radioactive influence was confirmed.

Because there was a rise trend in the pressure of PCV and it could possibly take long time to recover the heat removal function of the reactor, the line for PCV pressure control vent was configured (so that it could vent in an action by opening the outlet valve in S/C side).

#### **e. State of the spent fuel pool cooling system**

The facilities for SFP cooling maintained the water level of SFP more than its overflow level by FPC, and the water temperature of SFP at around 35°C before the earthquake occurred. However, because of the trip of FPC pumps due to the influence of the quake ("skimmer surge tank water level very low" or "pump suction pressure low"), the inundation of SW pumps (A, B, C) of the non-safety service water system near the water intake outside the building and the submersion of RCW pumps (A, B, C) on the first basement of the seawater heat exchanger building, all of them became inoperable and unable to supply water to FPC heat exchanger, and therefore SFP cooling by FPC became unavailable.

As a result, the water temperature of SFP has reached the maximum of 62°C, but by switching cooling water of FPC heat exchanger from RCW to RHRC for

SFP cooling at 16:35 on 15 March, the water temperature of SFP dropped to around 35°C at 17:00 on 16 March as low as before the earthquake.

The mentioned above suggests that although SFP temporarily lost its cooling function, it successfully satisfied the operation limits and conditions (SFP water level; close to the overflow level, water temperature; 65°C or less) defined by the Safety Preservation Rules of Nuclear Facilities.

**f. State of the “power supply” function**

The distribution systems were all available just after the automatic shutdown of the reactor, but the emergency power source (P/C 4C-2, 4D-2) became unavailable because the seawater heat exchanger building was submerged due to the tsunami.

Just after the automatic shutdown of the reactor all of the emergency DGs (A system, B system and HPCS system) were operable, but after the tsunami reached, because RHRS pumps (A, B, C, D) and EECW pumps (A, B) became unable to start, the emergency DGs (A, B) became also unavailable.

In a later recovery procedure, among the loads of the unavailable emergency power source (P/C 4D-2), RHRC pump (B) and RHRS pump (D) were allocated power to cool down the reactor and SFP, by the installment of temporary cords and the power supply from the emergency power source (P/C 3D-2) of the seawater heat exchanger of the reactor 3, and to EECW pump (B) by the high voltage power supply vehicle prepared from outside the site (performed on 14 March).

By this procedure, the emergency DG (B) was in operable condition, and the emergency power source (M/C 4D) became ready to receive power from the emergency DG (B) even if the external power source was lost.

Later, the temporary power source for the EECW pump (B) was switched from the high voltage power supply vehicle to the emergency power source (P/C 4D-1) (switched on 29 March).

The emergency DG (HPCS) was in operable condition from the time of the automatic shutdown of the reactor, and therefore the emergency power supplies enough to cool down the reactor and SFP had been secured.

**Table Appendix 1-4 Fukushima Daini Nuclear Power Station Reactor Unit 4  
Situation in Chronological Order After the Occurrence of the  
Earthquake**

Friday, March 11, 2011

- 14:46 Earthquake occurred.
- 14:48 Reactor automatically shut down ("trip due to high seismic acceleration" was issued), all of the control rods were fully inserted.
- 14:48 One of Tomioka line was shut down (line 2 tripped and continued receiving power from line 1)
- 15:05 Confirmed that the reactor was subcritical.
- 15:22 Reach of the first wave of tsunami (tsunami waves were observed intermittently from this time to 17:14).
- 15:33 CWP (C) was stopped by manual operation.
- 15:34 (appx.) Emergency DGs (A) (B) (H) automatically started. / DG (A) (B) stopped right away due to damage from the tsunami.
- 15:35 CWP (A) (B) automatically stopped.
- 15:36 MSIV was fully opened by manual operation.
- 15:36 RHR (B) was manually started (automatically stopped at 15:41).
- 15:37 RHR (A) was manually started (automatically stopped at 15:38).
- 15:46 Started depressurizing the reactor (SRV was automatically opened) (from this time on, the reactor pressure was controlled by automatic and manual operations).
- 15:50 All of Iwaido line shut down. (Line 2 shut down. Line 1 had been shut down for checkout before the earthquake occurred.)
- 15:54 RCIC was started by manual operation (from this time on, RCIC was started or stopped as required).
- 18:33 Because the start of seawater pump of the facility for heat removal of the reactor was not confirmed, it was judged that there occurred a particular event (loss of the heat removal function of the reactor) defined by Article 10, Clause 1 of Special Law for Nuclear Emergency.
- 19:02 "D/W pressure high" alert was issued.
- 19:14 D/W cooling system was started by manual operation.

Saturday, March 12, 2011

- 00:16 RCIC automatically stopped (due to the drop of the reactor pressure).
- 00:16 Alternative water injection by MUWC was started.
- 06:07 Because the temperature of S/C exceeds 100°C, it was judged that a particular event (loss of the function to control pressure) occurred as defined by Article 15, Clause 1 of Special Law for Nuclear Emergency.
- 07:23 Cooling down of S/C was performed by use of FCS cooling water (MUWP).
- 07:35 S/C spray was performed by use of MUWC.
- 11:17 Water injection to the reactor was switched from MUWC (alternative injection) to HPCS.
- 11:44 Started configuration of PCV pressure control vent line.
- 11:52 Completed configuration of PCV pressure control vent line.
- 13:38 (appx.) Received power from one of Iwaido lines (Line 2 was recovered).
- 13:48 Water injection to the reactor by HPCS was stopped (from this time on, this procedure was done as required).

Sunday, March 13, 2011

05:15 (appx.) Received power from two lines of Iwaido lines (Line 1 was recovered).

12:43 Drift alert was issued on control rod 10-19.

Monday, March 14, 2011

11:00 EECW (B) was started by manual operation (receiving power from the high voltage power vehicle).

13:07 RHRS (D) was started by manual operation (receiving power via temporary cords from P/C 3D-2).

14:56 RHRC (B) was started by manual operation (the motor was replaced./receiving power via temporary cords from P/C 3D-2)

15:42 RHR (B) was started by manual operation (started S/C cooling mode). Because RHR (B) started, it was judged to cancel the particular event (loss of the heat removal function of the reactor) defined by Article 10, Clause 1 of Special Law for Nuclear Emergency.

16:02 RHR (B) spray mode was started.

18:58 RHR (B) started water injection to the reactor in LPCI mode (stopped at 19:20) (from this time on, it was started/stopped as required).

20:19 Drift alert on control rod 10-19 was cleared.

21:07 Drift alert on control rod 10-19 was issued (from this time on, the alert was continuously issued).

22:07 Because greater radiation dose than 5 $\mu$ Gy/h was detected at MP (No.1), it was judged that a particular event (rise of radiation dose at site boundary) occurred as defined by Article 10, Clause 1 of Special Law for Nuclear Emergency. (the rise of radiation dose was estimated due to the radioactive release to the air caused by the accident in the Fukushima Daiichi Nuclear Power Station.)

Tuesday, March 15, 2011

00:12 Because greater radiation dose than 5 $\mu$ Gy/h was detected at MP (No.3), it was judged that a particular event (rise of radiation dose at site boundary) occurred as defined by Article 10, Clause 1 of Special Law for Nuclear Emergency. (the rise of radiation dose was estimated due to the radioactive release to the air caused by the accident in Fukushima Daiichi Nuclear Power Wtation.)

07:15 Because the temperature of S/C dropped under 100°C, it was judged that it recovered from the particular event (loss of the function to control pressure) defined by Article 15, Clause 1 of Special Law for Nuclear Emergency.

07:15 The water temperature of the reactor dropped under 100°C, and the reactor was in cold shutdown.

16:35 Cooling water of FPC heat exchanger was switched (from RCW to RHRC).

Wednesday, March 16, 2011

17:00 SGF water temperature was confirmed as around 35°C (recovered to the water temperature before the earthquake occurred).

## **Summary of the events on Onagawa Nuclear Power Station**

### **(1) Influence of the earthquake and tsunami**

All of Onagawa's reactors from 1 to 3 automatically shut down due to the earthquake off the Pacific coast of Tohoku. Some damage was found in part of the facilities due to the influence of the quake and tsunami, but there was no influence to the cooling function of the reactors and spent fuel pools because the external power and the emergency power supply were secured and the multiplicity and redundancy of the cooling facilities effectively worked, and all of the reactors quickly halted into a cold shutdown state.

The series of events on Onagawa are shown in Figure Appendix 1-2 with the event tree.

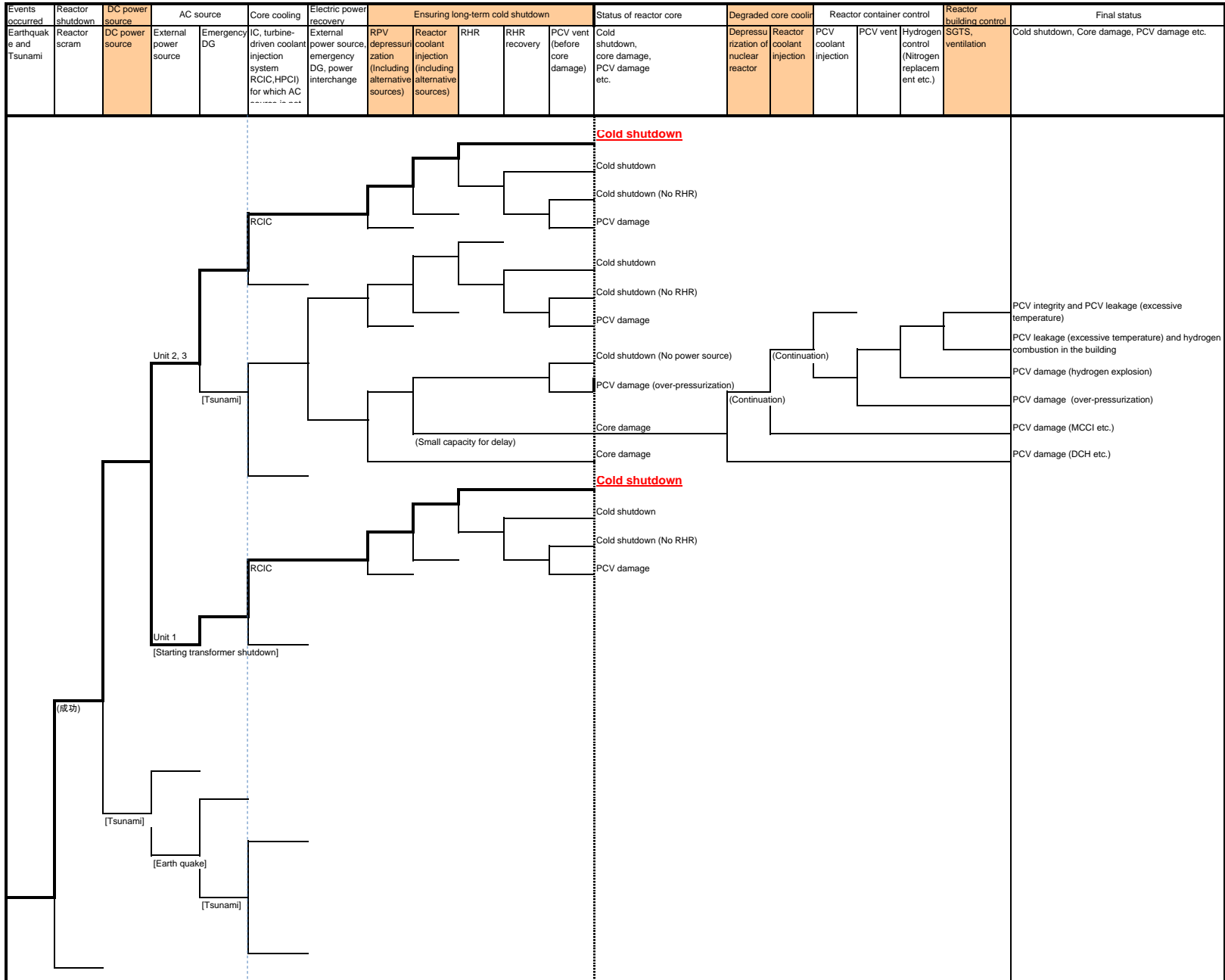

Diagram Appendix 1-2 Onagawa Nuclear Power plant disaster identification events tree

### **a. Impacts of earthquake**

The seismic intensity observed on site of power station during the Tohoku - Pacific Ocean Earthquake was slightly lower than Level 6. Even on a seismograph arranged for safety purpose on the 2nd basement level in the Unit 1 reactor building, 567.5gal was observed.

The maximum acceleration observed on each level of Onagawa Units 1~3 reactor buildings was almost equivalent, while some levels indicated the maximum acceleration that exceeded the maximum response acceleration for basic design earthquake ground motion  $S_s$  based on the Examination Guide for Seismic Design of Nuclear Power Reactor Facilities (as revised in September 2006).

With regard to the response spectrum for site ground recorded in the instrumental earthquake data, every location indicated almost equivalent response spectrum, while some values exceeded the response spectrum for basic design earthquake ground motion  $S_s$  (reflecting the impact of ground status above the seismograph). As a result of earthquake response analysis based on the current instrumental earthquake data and the evaluations of deformation of earthquake resisting wall in Onagawa Units 1~3 reactor buildings as well as the shear force applied on the earthquake resisting wall of each level, maintenance of the functions of reactor buildings was confirmed.

5 circuits supply power to Onagawa Power Station as external power sources (No.1 and No. 2 lines of Ojika Main Line [275 kV system], No.1 and No. 2 lines of Matsushima Main Line [275 kV system], Tsukahama Branch Line [66 kV system]). While only No. 2 line of Matsushima Main Line was available immediately after the Earthquake due to actuation of system protection circuit accompanying the accident of power transmission line in the jurisdiction area of TEPCO, No.1 line of Ojika Main Line was recovered at 20:12 of March 12, and then, No. 2 line of Ojika Main Line at 20:15 on the same day. This was followed by No.1 line of Matsushima Main Line at 10:47 of March 17 and Tsukahama Branch Line on 15:41 of March 26.

### **b. Impacts of tsunami**

The maximum height of tsunami confirmed on a current meter immediately after the Earthquake was O.P. + approx. 13m\* (at 15:29 of March 11) at maximum. This height did not exceed the altitude of Onagawa site (O.P.+ approx. 13.8 m\*)(Before the Earthquake: O.P.+ approx. 14.8m).

While a trace of sea water intrusion was observed due to runup in a part of plant site along the coastline, the waves did not reach the main buildings.

\* : This value reflects the diastrophism (Approx. -1m : based on the value of top line report) in vicinity of Onagawa announced by Geospatial Information Authority of Japan after the Earthquake.

## **(2) Unit 1**

### **a. Plant behavior after the Earthquake**

Upon the Earthquake occurred at 14:46 of March 11 during the constant rated thermal power operation, the seismic acceleration high signal was transmitted and control rods were fully inserted, which resulted in the automatic shutdown of the reactor.

The starting transformers were shut down due to short circuit / earth fault inside non-essential metal clad switchgear 6 – 1A that occurred in the Earthquake, which led to temporary loss of non-essential on-site power. While this caused a

shutdown of entire pump units in the Condensate and Feed Water System, prompt actuation of RCIC enabled water feed to the reactor.

Because the on-site non-essential power was lost temporarily through the starting transformer shutdown, control of the reactor pressure was achieved via SRVs instead of condensers by fully closing MSIVs. After reactor depressurization via SRVs, RCIC was shut down and water was fed to the reactor by using the control rod drive hydraulic control system (hereafter "CRD").

Cooling of the reactor was carried out without problem by RHR and the cold shutdown was achieved at 0:58 of March 12.

**b. Status of "Shutdown" function**

Under the impact of the Earthquake, seismic acceleration high signal ("O.P.15.00m vertical direction seismic sensor motion trip" : Set point 100gal) was transmitted and all control rods were fully inserted (14:46, March 11, 2011). Then the reactors were shutdown automatically as designed and subcriticality was confirmed at 15:05 on the same day.

**c. Status of "Cooling" function**

The starting transformers were shut down due to short circuit / earth fault inside non-essential metal clad switchgear 6 – 1A that occurred in the Earthquake, which led to temporary loss of non-essential on-site power. While this caused a shutdown of entire pump units in the Condensate and Feed Water System, prompt actuation of RCIC enabled water feed to the reactor.

Because the on-site non-essential power was lost temporarily through the starting transformer shutdown, control of the reactor pressure was achieved via SRVs instead of condensers by fully closing MSIVs. After reactor depressurization via SRVs, RCIC was shut down and water was fed to the reactor by using the CRD. Cooling of the reactor was carried out without problem by RHR and the cold shutdown was achieved at 0:58 of March 12.

**d. Status of "Confinement" function**

PCIS motions accompanying the reactor vessel low water level (L – 3) signal were normal and no abnormal value was observed on stack monitor, radioactive waste discharge water monitor and MP. There was no radioactive impact on the external environments.

**e. Status of spent fuel storage pool**

While the Earthquake caused FPC shutdown at 14:47 of March 11, it was restarted at 19:30 of the same day upon confirming that there was no abnormality in the equipment. During the shutdown, no significant elevation was seen on the temperature of spent fuel storage pool. The cause of FPC shutdown seems to be the actuation of level switch for "skimmer surge tank level low low" due to the seismic vibration, or, the drop of FPC pump suction pressure through temporal drop of spent fuel storage pool level due to the seismic vibration.

**f. Status of "Power Source" function**

With regard to the power source, the station was receiving the external power from No. 2 line of Matsushima Main Line via starting transformers. However, at 14:55 on March 11, on-site power was lost due to shutdown of the starting transformers. Accordingly, power was supplied to emergency bus by DG (A) and DG (B) based

on the design.

The cause of the starting transformer shutdown was the earth fault / short circuit occurred inside the non-essential metal clad switchgear 6 – 1A (this resulted in fire later), which actuated the overcurrent relay of the starting transformers.

Thereafter, integrity of the starting transformers was confirmed based on the appearance inspection and the measurement of the insulation resistance and the starting transformers were restored at 2:05 on March 12. After the restoration of the starting transformers, power supply of non-essential bus was recovered on by one excluding the non-essential metal clad switchgear 6 – 1A.

The emergency power supply needed to cool down the reactor and the spent fuel storage pool until the restoration of the starting transformers was secured.

## Table Appendix 1-5: Chronological report for Onagawa Unit 1 after the Earthquake

Before the Earthquake : Constant rated thermal power operation

March 11, 2011 (Friday)

14:46 East Japan Great Earthquake occurred  
(Seismic intensity observed on site: Slightly lower than Level 6)  
Vertical direction seismic acceleration high; Reactor automatic shutdown

14:47 Full insertion of all control rods was confirmed  
DGs (A), (B) automatic startup  
FPC pump (A) automatic shutdown

14:55 DGs (A), (B) load operation started

14:59 RCIC manual startup

15:00 RHR pump (A) manual startup (For S/P cooling operation)

15:01 RHR pump (C) manual startup (For S/P cooling operation)

15:05 Reactor subcriticality was confirmed

15:05 RHR pump (B) manual startup (For S/P cooling operation)

15:12 RHR pump (D) manual startup (For S/P cooling operation)

15:55 RHR pump (A), (C) automatic shutdown

16:15 RHR pump (A) manual restart (For S/P cooling operation)

Approx.17:10 Reactor depressurization started (SRV was used)

18:29 RCIC turbine automatic shutdown (via L-8)

Approx.19:30 FPC pump (A) manual startup (Fuel pool cooling)

20:20 CRD pump (A) manual startup (Water feed to reactor)

21:56 RHR pump (A) manual shutdown (SHC preparation [for flushing])

23:46 RHR pump (A) manual startup (SHC mode)

March 12, 2011 (Saturday)

0:57 Reactor coolant temperature reached 100 °C

0:58 Reactor status "Cold shutdown"

2:05 After the power supply (restoration) of starting transformers, non-essential buses were recovered excluding M/C6-1A which was damaged by fire.

### **(3) Unit 2**

#### **a. Plant behavior after the Earthquake**

The reactor was in start-up operation from 14:00 on March 11 for the 11th periodical inspection. After the Earthquake occurred at 14:46 on the same day, seismic acceleration high signal was transmitted. Then, all control rods were fully inserted immediately and the reactor was shut down.

Because the Unit 2 was in the status immediately after starting reactor operation and the status immediately before the Earthquake was of subcriticality with reactor water temperature lower than 100 °C, cold shutdown was implemented at 14:49 on March 11 by operating the reactor mode switch “Shutdown.”

#### **b. Status of “Shutdown” function**

The reactor was in start-up operation from 14:00 on March 11 for the 11th periodical inspection. After the Earthquake occurred at 14:46 on the same day, seismic acceleration high signal (“R/B bottom horizontal direction seismic acceleration high trip” : set point 200gal) was transmitted. Then, all control rods were fully inserted immediately and the reactor was automatically shut down as designed. Status of subcriticality was maintained.

#### **c. Status of “Cooling” function**

Because the Unit 2 was in the status immediately after starting reactor operation for the 11th periodical inspection and the status immediately before the Earthquake was of subcriticality with reactor water temperature lower than 100 °C, cold shutdown was implemented at 14:49 on March 11 by operating the reactor mode switch “Shutdown.”

Under the impact of Tsunami accompanying the Earthquake, the seawater intruded from the cooling water intake canal of the sea water pump area entered a part of reactor building via underground trench, which resulted in the function loss of 2 systems (RCW-B and HPCW). However, because RCWA system was sound, there was no negative impact on the cooling function of reactors by RHR.

#### **d. Confinement**

No abnormal value was observed on stack monitor, radioactive waste discharge water monitor and MP. There was no radioactive impact on the external environments.

#### **e. Status of spent fuel storage pool**

While the Earthquake caused FPC shutdown at 14:47 of March 11, it was restarted at 20:29 of the same day upon confirming that there was no abnormality in the equipment. During the shutdown, no significant elevation was seen on the temperature of spent fuel storage pool.

The cause of FPC shutdown seems to be the actuation of level switch for “skimmer surge tank level low low” due to the seismic vibration, or, the drop of FPC pump suction pressure through temporal drop of spent fuel storage pool level due to the seismic vibration.

Under the impact of Tsunami accompanying the Earthquake, the seawater intruded from the cooling water intake canal of the sea water pump area entered a part of reactor building via underground trench, which resulted in the function loss of 2 systems (RCW-B and HPCW). However, because RCWA system was sound, there was no negative impact on the cooling function of spent fuel storage pool by

FPC similar to the case with reactor cooling function by RHR.

**f. Status of “Power Source” function**

With regard to the power source, the station was receiving the external power from No. 2 line of Matsushima Main Line via starting transformers and on-site power has been secured constantly.

Under the impact of vibration caused by the Earthquake, generator loss of field signal was transmitted, which resulted in the automatic start-up of DGs (A) / (B) and the high pressure core spray system DG (hereafter “DG(H)”) followed by stand-by status with no load operation. Thereafter, the seawater intruded from the cooling water intake canal of the sea water pump area entered a part of reactor building via underground trench, which resulted in the function loss of 2 systems (RCW-B and HPCW). While this event triggered the automatic shutdown of DG(B) and DG(H), DG(A) was sound and, even if the external power was lost, the emergency power supply needed to cool down the reactor and the spent fuel storage pool could be secured.

**g. Loss of function in RCW-B, RSW-B and HPCW systems**

Under the impact of vibration caused by the Earthquake, generator loss of field signal was transmitted, which resulted in the automatic start-up of DGs (A) / (B) / (H) followed by no load operation. Then, at 15:34, RCW pump (B) shut down automatically and the RCW pump (D) that was started up as a back-up immediately also shut down automatically. This led to the loss of cooling water supply for emergency DG (B) and it was shut down automatically at 15:35. Further at 15:41, HPCW pump shut down automatically, which resulted in the loss of cooling water supply for emergency DG (H) and it was shut down automatically at 15:42.

Inspection of the site revealed that the sea water intruded into the RCW heat exchanger (B) area, HPCW heat exchanger area and the staircase that accessed the elevator in the uncontrolled area on the 3rd basement level of the reactor building (submergence depth: approx. 2.5m), and that the RCW pumps (B) / (D) and HPCW pump were submerged and the sea water intruded also into the RCW heat exchanger (A) area (submergence depth: approx. 0.5m). Therefore, the task to drain sea water in the submerged area outside the building was started at 20:25 by using temporary pumps. The draining process was completed at 10:30 on March 16.

Further, the patrol after the Earthquake revealed that the sea water system (hereafter “RSW”) pump (B) area in the outdoor sea water pump area was submerged and the RSW pumps (B) / (D) installed in this area might have been submerged, too.

We inspected the motors of RCW pumps (B) / (D), RSW pumps (B) / (D) and HPCW pump affected by sea water intrusion (or suspected sea water intrusion) as well as the submerged actuator of the motor operated valves in the factory. As a result of an overhaul inspection, rusts were observed on all the components, while insulation resistance value of some components satisfied the criteria. Accordingly, these pumps were judged as incapable to satisfy the functions necessary to secure safety of the reactor facility.

This event belongs to the type of events for which reporting is mandatory based on the Rules for the Installation, Operation, etc. of Commercial Power Reactors, Article 19-17, Item 1, and No.3.

To protect the area against back wave of tsunami, level instrumentation for CWP

automatic shutdown (hereafter “this level instrumentation”) was installed additionally in the RSW pump (B) section of the sea water pump area (in 2002). However, consideration in selecting the location for installation as well as water shielding measure were insufficient to protect the area from the impacts of the waves that push forward.

Therefore, the following process was estimated: Under the impact of Tsunami accompanying the Earthquake, the seawater intruded from the cooling water intake canal entered the sea water pump area via this level instrumentation box, causing submergence of RSW pump (B) area and water intrusion in a part of reactor building via underground trench. This event resulted in the function loss of RCW-B system, RSW-B system and HPCW system.

While this type of level instrumentation is installed also in the Unit 1 and the Unit 3, there was no damage on the RCW system etc. because they are installed in the different area (dust extractor area).

Although there was a trace of sea water intrusion also into the dust extractor area, the cover of this level instrumentation was not detached. Therefore, we estimate that the sea water must have entered from the opening of the dust extractor installed in front of this level instrumentation.

Following countermeasures were implemented to prevent recurrence of the loss of function in RCW (B), RSW (B) and HPCW systems:

- This level instrumentation was detached and water shielding work was carried out to its opening.  
The location to install this level instrumentation is to be changed to an area less susceptible to sea water intrusion.
- Repair work was conducted on the section from sea water pump area to the pipe penetration to trench and the cable tray penetration.
- As mid-term / long-term countermeasures, we will implement the improvement of water sealing performance of the building doors and the installation of tide embankment and tide wall as a part of countermeasures to prevent submergence by tsunami. These measures are implemented within the framework of emergency safety countermeasures for Onagawa Nuclear Power Station complied based on the instructions of Minister of Economy, Trade and Industry dated March 30, 2011, “On the Implementation of Emergency Safety Measures at Other Power Plants drawn from the 2011 Accident at Fukushima Dai-ichi and Dai-ni Nuclear Power Stations (Minister’s Instructions, Released on March 30th)”

With regard to the submerged pump motors and motor operated valve actuators, repair work (cleaning and maintenance etc.) was conducted based on the result of overhaul inspection.

## Table Appendix 1-6: Chronological report for Onagawa Unit 2 after the Earthquake

Before the Earthquake : “start-up” immediately before the Earthquake for the 11th periodical inspection

March 11, 2011 (Friday)

14:00 Reactor mode switch “Refueling” → “Start-up” (Reactor status “Start-up” )

Control rod withdrawal started

14:46 East Japan Great Earthquake occurred  
(Seismic intensity observed on site: Slightly lower than Level 6)  
R/B bottom horizontal direction seismic acceleration high; Reactor automatic shutdown

14:47 Full insertion of all control rods was confirmed  
Emergency DGs (A), (B) and (H) automatic startup

\* Based on generator loss of field signal

FPC pump (B) automatic shutdown

14:49 Reactor mode switch “Start-up” → “Shutdown”  
(Reactor status “Cold shutdown”)

15:34 RCW pumps (B) and (D) automatic shutdown (due to pump submergence)

15:35 Emergency DG (B) automatic shutdown (due to RCWs (B) and (D) shutdown)

15:41 HPCW pump automatic shutdown (due to pump submergence)

15:42 Emergency DG (H) automatic shutdown (due to HPCW shutdown)

20:29 FPC pump (A) manual startup (Fuel pool cooling)

March 12, 2011 (Saturday)

12:12 RHR pump (A) manual startup (SHC mode)

**Table Appendix 1-7: Chronological report on RCW-B system, RSW-B system and HPCW for Onagawa Unit 2**

March 11, 2011 (Friday)

- 14:00 Reactor start-up
- 14:46 Earthquake occurred (Seismic intensity observed on site: Slightly lower than Level 6)  
Reactor automatic shutdown  
Emergency DGs (A), (B), (H) automatic startup (No-load operation)
- 14:49 Issue of great tsunami alarm
- Approx.15:21 The 1st wave of tsunami (An operator confirmed the time visually)
- 15:34 RCW pump (B) automatic shutdown  
RCW pump (D) automatic shutdown (Shutdown immediately after started up as back-up)
- 15:35 Emergency DG (B) shut down automatically by “RCW differential pressure low” signal
- 15:41 HPCW pump automatic shutdown
- 15:42 Emergency DG (H) shut down automatically by “HPCW differential pressure low” signal
- Approx.16:00 The operator who inspected the reactor building confirmed intrusion of water in the RCW heat exchanger (B) area on the lowest basement level, stairs (2 points) on the 3rd basement level to access the HPCW heat exchanger area and in the RCW heat exchanger (A) area (uncontrolled area).
- 16:01 RSW pump (B) manual shutdown (due to submergence of RCW B system)
- 16:06 HPSW pump manual shutdown (due to submergence of HPCW system)
- Approx.20:12 As a result of analysis of the intruded water, no radioactivity was detected and the water was found as the sea water.
- 20:25 Temporary pumps were installed and work to drain the sea water flow into the 3rd basement level of the reactor building (uncontrolled area) to outside the building was started.

March 16, 2011

- 10:30 Draining of the sea water from the building was completed.

#### **(4) Unit 3**

##### **a. Plant behavior after the Earthquake**

Upon the Earthquake occurred at 14:46 of March 11 during the constant rated thermal power operation, the seismic acceleration high signal was transmitted and control rods were fully inserted, which resulted in the automatic shutdown of the reactor.

Under the impact of Tsunami, a “sea water pump area level low low” signal was transmitted, which resulted in the shutdown of CWP. At the same time, submergence under the sea water intruded in the sea water pump area of the heat exchanger building caused the shutdown of Turbine Building Closed Cooling Sea Water System (hereafter “TSW”) pumps. Due to the loss of cooling water supply caused by this event, all of reactor feed water pumps were manually shut down. Then, RCIC was started up to feed water to the reactor, and reactor pressure control was carried out by SRVs upon fully closing MSIVs, because the condensation of main steam by using condenser failed.

After the shutdown of RCIC accompanying the reactor depressurization, water was supplied to the reactor by CRD. Thereafter, cooling of the reactor was conducted by RHR without problem and a cold shutdown of the unit was achieved at 1:17 on March 12.

##### **b. Status of “Shutdown” function**

Upon the Earthquake occurred at 14:46 of March 11 during the constant rated thermal power operation, the seismic acceleration high signal (“R/B bottom vertical direction seismic acceleration hightrip” : Setpoint 100gal) was transmitted and control rods were fully inserted, which resulted in the automatic shutdown of the reactor as designed. Status of subcriticality was confirmed at 14: 47 on the same day.

##### **c. Status of “Cooling” function**

Under the impact of back wave of Tsunami, a “sea water pump area level low low” signal was transmitted, which resulted in the shutdown of CWP as designed. At the same time, submergence under the sea water intruded in the sea water pump area of the heat exchanger building caused the shutdown of TSW pumps. Due to the loss of cooling water supply caused by this event, all of reactor feed water pumps were manually shut down. Then, RCIC was started up to feed water to the reactor, and reactor pressure control was carried out by SRVs upon fully closing MSIVs, because the condensation of main steam by using condenser failed.

To feed water to the reactor after the shutdown of RCIC accompanying the reactor depressurization, multiple options could be considered; i.e. the ECCS by using suppression pool water as water source, the MUWC by using condensate storage tank as water source and so on. We selected MUWC using condensate storage tank as water source to feed water to the reactor with giving considerations to the decrease of decay heat through plant shutdown and the maintenance of reactor water quality.

Cooling of the reactor was carried out without problem by RHR and the cold shutdown was achieved at 1:17 of March 12.

##### **d. Status of “Confinement” function**

No abnormal value was observed on stack monitor, radioactive waste discharge water monitor and MP. There was no radioactive impact on the external

environments.

**e. Status of spent fuel storage pool**

While the Earthquake caused FPC shutdown at 14:47 of March 11, it was restarted at 15:23 of the same day upon confirming that there was no abnormality in the equipment. During the shutdown, no significant elevation was seen on the temperature of spent fuel storage pool.

The cause of FPC shutdown seems to be the actuation of level switch for “skimmer surge tank level low low” due to the seismic vibration, or, the drop of FPC pump suction pressure through temporal drop of spent fuel storage pool level due to the seismic vibration.

**f. Status of “Power Source” function**

With regard to the power source, the station was receiving the external power from No. 2 line of Matsushima Main Line via starting transformer, and on-site power has been secured constantly. Further, all of the emergency DGs were sound and, even if the external power was lost, the emergency power supply needed to cool down the reactor and the spent fuel storage pool could be secured.

## Table Appendix 1-8: Chronological report for Onagawa Unit 3 after the Earthquake

Before the Earthquake : constant rated thermal power operation

March 11, 2011 (Friday)

- 14:46 East Japan Great Earthquake occurred  
(Seismic intensity observed on site: Slightly lower than Level 6)  
R/B bottom vertical direction seismic acceleration high; Reactor automatic shutdown
- 14:47 Full insertion of all control rods was confirmed
- 14:57 Reactor subcriticality was confirmed
- 15:26 RCIC manual startup (Water feed to reactor)
- 15:28 RSW pump (D) manual startup (S/P cooling operation)
- 15:30 RCW pump (B) manual startup (S/P cooling operation)
- 15:30 RHR (B) manual startup (S/P cooling operation)
- 15:43 RSW pump (C) manual startup (S/P cooling operation)
- 15:44 RHR (A) manual startup (S/P cooling operation)
- 15:45 RCW pump (A) manual startup (S/P cooling operation)
- 16:40 Reactor depressurization started (by using SRV)  
RCIC turbine shutdown(by L-8)
- 16:57 RCIC manual startup (Water feed to reactor)
- 21:44 RHR pump (A) manual shutdown (SHC preparation)
- 21:45 RCIC turbine manual shutdown
- 21:54 Water feeding by MUWC (Water feed to reactor)
- 23:51 RHR pump (A) manual startup (SHC mode)

March 12, 2011 (Saturday)

- 1:17 Reactor coolant temperature lower than 100 °C (Reactor status "Cold shutdown")

## Summary of Events in Tokai Daini Nuclear Power Station

### (1) Impacts of earthquake and tsunami

The Earthquake attacked the Tokai Daini Nuclear Power Station during its constant rated thermal power operation. At 14:48 on March 11, the reactor shut down automatically due to turbine trip caused by large vibration of turbine bearing under the impact of the Earthquake. Immediately after the Earthquake, all three circuits for external power were lost. However, the power source for emergency components was secured because of the start-up of 3 emergency DG units. Immediately after the automatic shutdown of the reactor, its water level was kept normal by RCIC and HPCS and the reactor pressure was controlled by SRV. Decay heat after the reactor shutdown was removed through cooling of RHR suppression pool.

Thereafter, under the impact of tsunami, sea water pumps for cooling Emergency DG2C were automatically shut down, which resulted in unavailability of Emergency DG2C. Nevertheless, emergency power could be secured by operation of the remaining 2 emergency DGs without causing any disturbance to the cooling function for the reactor and SFP. At 0:40 on March 15, the cold shutdown of the reactor was achieved.

The development of events in Tokai Daini Nuclear Power Station is illustrated as an event tree in Figure Appendix 1-3.

Events occurred	Reactor shutdown	Direct power source	AC source		Core cooling	Electric power recovery	Ensuring long-term cold shutdown					Status of reactor core
			External power source	Emergency DG			RPV depressurization (Including alternative sources)	Reactor coolant injection (including alternative sources)	RHR	RHR recovery	PCV vent (before core damage)	
Earth quake and Tsunami	Reactor scram	DC power source	External power source	Emergency DG	High pressure core cooling system (RCIC,HPCS)	External power source, emergency DG, power interchange	RPV depressurization (Including alternative sources)	Reactor coolant injection (including alternative sources)	RHR	RHR recovery	PCV vent (before core damage)	Cold shutdown, core damage, PCV damage etc.
												<p><b>Cold shutdown</b></p> <p>Cold shutdown</p> <p>Cold shutdown(No RHR)</p> <p>PCV damage (over-</p>

Figure Appendix 1-3 Fukushima Daiichi Nuclear power plant disaster identification events tree

## Impacts of earthquake

Seismic intensity observed on site (Tokai in Tokai Village) was slightly lower than Level 6, and the maximum accelerations recorded on a seismograph arranged on the 2nd basement level of the reactor building was 214gal in the North-South direction, 225 gal in the East-West direction and 189 gal in the vertical direction. It was confirmed that the maximum acceleration observed on each level of the reactor building was maintained below the maximum acceleration for the basic design earthquake ground motion  $S_s$  based on the Examination Guide for Seismic Design of Nuclear Power Reactor Facilities (as revised in September 2006). With regard to the response spectrum for the instrumental earthquake data, while some records indicated that they locally exceeded the response spectrum for the basic design earthquake ground motion  $S_s$ , the analysis result revealed that the data maintained the level below the response spectrum for the basic design earthquake ground motion  $S_s$  in most frequency bands including those where natural frequencies for the important components in terms of seismic design centered upon.

Immediately after the Earthquake, 3 external power circuits (275kV systems and 154kV system) were lost. Thereafter, 154kV system was restored on March 13 and one circuit of 275kV systems was restored on March 17. Another 275kV system was recovered on April 27. With this, all circuits of the external power were recovered.

## Impacts of tsunami

Status of flood caused by tsunami during the Earthquake was inspected at the intake area. As a result, it was confirmed that, at around 15:35, the intake area located at altitude\* +3.3m (approx.) (altitude before the Earthquake) suffered flooding with approx. 1m depth (depth of submergence is estimated based on the images from monitor cameras in every case).

Further, it was confirmed that the submergence of approx. 2m occurred in the intake area also at around 16:51. This was followed by submergence of several times (depth <1m) in the intake area.

Based on the results of on-site investigation including the investigation of flood traces, the height of tsunami in the Tokai Daini Nuclear Power Station is estimated as altitude\* +5.3m (approx.) (altitude after the diastrophism investigation).

Because this height did not exceed the height of Tokai Daini Nuclear Power Station site (altitude\* +8.0m (altitude before the Earthquake)), the tsunami didn't reach the main buildings of the power station.

The tsunami reached the point around the sea water pump area in the plant site along the coastline (altitude\* +3.3m (altitude before the Earthquake)). While there was no water intrusion from above the North-South side walls of the sea water pump area because they had altitude \* +6.1m height (altitude before the Earthquake) as a countermeasure against tsunami, some water intrusion from penetration hole was observed in the north pump area, since the area was under construction for sealing the side wall penetrations.

\* : This altitude is based on Tokyo Peil (T.P.) (i.e. It does not reflect the ground subsidence caused by diastrophism).

## (2) Status of “Shutdown” function

Under the impact of the Earthquake, vibration of turbine bearing increased and “turbine bearing vibration high” signal was transmitted, which resulted in a turbine

trip and, as a consequence, an automatic shutdown of the reactor.

All control rods were fully inserted normally (at 14:48 on March 11) and the reactor core was maintained in subcriticality status.

### **(3) Status of “Power Source” function**

While 3 external power circuits were lost upon occurrence of the Earthquake, 3 emergency DG units (2C, 2D and HPCS) started up automatically and the power supply to the emergency power bus was started.

Emergency DG sea water pump (2C) shut down due to intrusion of sea water into the north pump tank under the impact of tsunami. This event caused an unavailability of Emergency DG2C, which led to the power loss of the Emergency AC Power Bus 2C.

Because the power on the Emergency AC Power Bus 2D and HPCS Bus could be ensured continuously, power supply to emergency components could be maintained.

With regard to emergency DC power, power charges to the batteries as well as a power supply to the DC power load were implemented from the emergency power bus. While the Emergency AC Power Bus 2C was in power loss, the DC power source connected to this bus was switched to the power supply from the sound emergency AD power bus and the power charge to the batteries was conducted without problem. Therefore, the DC power was not lost from site.

### **(4) Status of “Cooling” function**

Due to the water level fluctuation immediately after the reactor shutdown, an automatic start-up of HPCS and RCIC as a part of ECCS occurred. This secured the function to inject coolant to the reactor in high pressure status, which contributed to the maintenance of normal water level of the reactor. Thereafter, the maintenance of the reactor water level was achieved by RCIC (at first CST, and then, suppression pool was used as water source) and the pressure control for the reactor was implemented by SRVs.

To remove decay heat after the reactor scram, RHR was started up manually and the cooling of suppression pool was started.

Excluding the Emergency DG sea water pump (2C) installed in the north pump tank, no negative impact on the function was observed on the RHR sea water pumps (A) / (C) and the sea water pumps (A) / (C), although they were submerged up to the bottom level of the generators.

### **(5) Status of “Confinement” function**

Water level fluctuation (level drop) immediately after the reactor scram caused normal actuation of the containment isolation system, leading to isolation of reactor containment.

Similarly, water level fluctuation (level drop) immediately after the reactor scram caused automatic isolation of the reactor building and the normal swathing of reactor building ventilation system from normal ventilation system to the Standby Gas Treatment System (SGTS).

### **(6) Status of spent fuel pool cooling**

Sloshing by the Earthquake actuated an alarm for the spent fuel pool level (“FUEL POOL LEVEL HI/LO”). At the same time, the water level decreased by approx. 20cm from the normal level, because the flooding from the pool occurred.

To address this event, water was filled in the spent fuel storage pool by using CST water.

While the water level dropped, spent fuels stored in the spent fuel storage pool were sufficiently covered by water continuously (fuel top + approx. 7m).

While the Fuel Pool Cooling and Clean-up System was shut down due to loss of external power, cooling was resumed by power supply from the sound Emergency DG2D.

#### **(7) Cause of sea water intrusion into north pump tank under the impact of tsunami and countermeasures**

With regard to the emergency sea water pump tanks, separation walls of altitude\*+6.1m height (altitude before the Earthquake) had been installed to protect the area against tsunami of altitude\* + 5.7m height (approx.) (altitude before the Earthquake). At the time point of March 11, a construction work for water sealing for pump tanks was going on.

The height of the tsunami observed in the current disaster was altitude\* + approx. 4.8~5.3m (altitude after the diastrophism investigation). While this height did not exceed the height of the separation walls of altitude\* +6.1m (altitude before the Earthquake), sea water intruded in the north pump tank from following 2 points under water sealing work.

The water sealing work on the south pump tank had been completed then.

- ① Opening between the north pump tank and ASW strainer area (discharge channel)
- ② Unsealed structure of the cable pit

Therefore, blockage was implemented to these 2 points by placing of concrete.

\* : This altitude is based on Tokyo Peil (T.P.).

## **Table Appendix 1-9: Chronological report for Tokai Daini Nuclear Power Station after the Earthquake**

Before the Earthquake : Constant rated thermal power operation

March 11, 2011 (Friday)

- 14:46 The Earthquake occurred (Seismic intensity observed on site: Slightly lower than Level 6)
- 14:48 The reactor shut down automatically with turbine stop valve closure due to automatic shutdown of turbines caused by large vibration of turbine bearing.
- 14:48 Full insertion of all control rods was confirmed
- 14:48 PCIS actuation
- 14:48 HPCS automatic startup
- 14:49 RCIC automatic startup
- 14:52 HPCS injection valve automatic closure and RCIC automatic shutdown (by Reactor Water Level High (L-8))
- 15:01 Suppression pool cooling operation started by Residual Heat Removal A System (Manual)
- 15:10 Reactor subcriticality was confirmed
- 15:36 RCIC manual startup (Water feed to reactor)
- 16:40 Suppression pool cooling operation started by Residual Heat Removal B System (Manual)
- 19:01 Emergency DG sea water pump 2C automatic shutdown
- 19:21 Suppression pool cooling operation by Residual Heat Removal A System shut down (Manual)
- 19:22 Emergency DG2C manual shutdown
- 21:52 Reactor depressurization started (by using SRV intermittently)

March 12, 2011 (Saturday)

- 11:37 Control of reactor water level was switched from RCIC to HPCS
- 13:11 RCIC manual shutdown (as a result of reactor pressure drop)

March 13, 2011 (Sunday)

- 19:41 Power supply from external back-up power (154 kV) to the on-site power sources one after another

March 14, 2011 (Monday)

- 23:43 Shutdown cooling mode operation started by Residual Heat Removal A System

March 15, 2011 (Tuesday)

- 0:40 Reactor coolant temperature lower than 100 °C (Reactor status "Cold shutdown")

March 17, 2011 (Thursday)

- 15:47 Tokai Nuclear Power Station Line No.1 (275 kV) was charged

March 22, 2011 (Tuesday)

- 22:10 Emergency DG2C stand-by (Inspection of Sea Water Pump 2C completed)

April 27, 2011 (Wednesday)

- 16:29 Tokai Nuclear Power Station Line No.2 (275 kV) was charged

## Appendix-2 Agenda for Future Review

In this report, we summarized the results of investigation into the initial phase of the accident in Fukushima Daiichi Nuclear Power Station, the analysis of the accident causes and the countermeasures considered effective based on the lessons we learned from the accident.

However, because there are many aspects that require further collection / analysis of information regarding the international approaches for improving safety, further approaches to control the impacts of this accident, and the consultations with national and local governments, we still have a series of agenda that are not included in the scope of the current review. Therefore, we would like to identify the items requiring examination in future by nuclear industry community for further improvement of safety in nuclear power stations.

In the current review, we did not cover the analysis of root cause of the accident including the organization factors, because it was impossible for TEPCO staffs in charge of each area to share their time for interview that may last for long time due to their intensive efforts and time pressure they are exposed to for controlling this accident. If additional information that are not accessible to us at this moment become unveiled in future, we want to proceed with our examination by integrating the new information.

Agenda for future review are shown below:

- Countermeasure against the fire associated with earthquake  
Industry-wide examinations have been made and various countermeasures have been implemented to secure plant-specific safety against the fire so far. However, we want to proceed with our examination on items, if any, that need to be addressed based on the findings from the current earthquake.
- Countermeasure against the flood associated with earthquake  
With regard to the flood, assessments of impacts on safety-related components have been made and protection measures have been examined since the Niigata-oki Earthquake. However, we want to proceed with our examination on items, if any, that need to be addressed based on the findings from the current earthquake.
- Countermeasure against the facility destruction by terrorist attacks  
Since 9.11 in 2001, The United States have promoted diverse commitments to prevent terrorist attacks on the nuclear power stations. It is necessary for Japan to promote examinations on how to secure functions of nuclear power stations (“shutdown,” “cooling” and “confinement”) to address the large-scale destruction of facilities by terrorist attacks.
- Reinforcement of disaster preparedness measures  
In the current accident of Fukushima Daiichi Nuclear Power Station, the extent of discharge / diffusion of radioactive materials exceeded the scope of impacts estimated in the conventional disaster preparedness plans. Radical review of the disaster preparedness plans are needed with reflecting the findings of the current disaster. Realization of elaborate countermeasures should be sought for from the standpoint of nuclear power station owners with reflecting the contents to be reviewed.

- Reconsideration of approaches for safety culture
 

Industry-wide serious reconsideration is needed on the cause of inability to prevent this accident including the aspects such as “Why was preventive measure not implemented in anticipation of tsunami in the scale far beyond the estimation?” and “Why was countermeasure not taken in anticipation of long time power loss?” The results of the reconsideration should be reflected in the approaches to nurture the safety culture with the purpose to prevent recurrence of the accident.
- Approaches to PSA
 

While industry-wide arguments have been accumulated on the seismic probabilistic safety assessment (PSA) so far, the current accident calls an enhanced attention to the importance of PSA-based approaches to natural phenomena. Accelerated review and establishment of various types of PSA evaluation methods are necessary to implement appropriate evaluation of each nuclear power plant facility. Further, identification of the points to be reinforced and the countermeasures to address the points are desired.
- Approaches to human resources development
 

It is impossible for the industry to learn lessons directly from this accident as to “what kind of strategy should be in place to develop appropriate human resources.” From the standpoints of improving safety of nuclear power stations and the nuclear disaster preparedness, it is necessary for the industry to examine possible policies for development of human resources in future so as to establish a system to enable a systematic human resource recruitment / education with wide outreach. Further, at least the educations to hand down the lessons from this accident as well as the leaning of the new countermeasures are essential and it is imperative to establish a mechanism to keep this cycle running on continuous basis.
- Approaches to the agenda related to multiple reactor siting
 

At present, the scope of impact and problems associated with specific measures against the accident in multiple-reactor site are yet to be identified except the hydrogen explosion occurred in the Unit 4 caused by the hydrogen generated in the Unit 3 and migrated to the Unit 4 via an exhaust line.  
Based on the experience of explosion in the Unit 4, we plan to screen out the similar type of systems from the standpoint to ensure independency as one of the lessons learned from this accident.  
If further information concerning the multiple-reactor siting is obtained in the process of the accident investigation in future, we want to proceed with our approach to extract the lessons on the multiple-reactor siting and examination on specific countermeasures.  
We consider that the manpower deployment should be reviewed depending on the necessity through the trainings based on the assumption of simultaneous accidents in multiple units.
- Approaches to the findings related to accident handling
 

While many kinds of works are going on currently to terminate the accident, we receive various lessons from each of these works. For instance, with regard to the handling of retained water, there are various lessons in a series of its

process including the generation of the polluted water, prevention of its leakage to the environment, management and disposal. Approaches to the issues related to the accident handling should be continued on mid-term / long-term basis.

- Containment filter vent

Based on the experience of this accident, necessity and importance of containment ventilation are recognized to prevent damage of the containment through pressurization. However, with regard to the containment ventilation particularly under the severe accident condition, impact of discharged radioactive materials on surrounding environments is a concern.

To address this issue, some overseas countries (Europe) install containment filter vent to suppress discharge of high amount of radioactive materials to the atmosphere as one of the countermeasures for severe accidents. This practice has yet to be introduced to Japan.

In the current accident, the discharge route of radioactive materials has not been identified yet. Therefore, it is unknown at present whether or not the installation of a containment filter vent could have prevented discharge of the high amount of radioactive materials. Nevertheless, appropriateness of installing a containment filter vent should be examined as a part of countermeasure to mitigate impacts on the surrounding environment.

## **Appendix-3 Comparison with Government Report / NRC Task Team Report**

In conducting the current review, we, as the industry, extracted the items that need to be addressed from the wide range of issues to prevent recurrence of the accident in terms of both direct factors and indirect factors based on the clearly defined facts at this stage without eliminating the guessing as much as possible. Further, we manifested our continued commitment to the review by identifying the agenda requiring further examination in future besides the lessons perceived from development in the accident of Fukushima Daiichi Nuclear Power Station. Meanwhile, in the report of Japanese Government to the IAEA Ministerial Conference on Nuclear Safety held in June 2011, 28 lessons were compiled that require commitments by operators, national government and local authorities. To clarify the industry's attitude to these 28 items, a comparison between these items and the lessons compiled by the industry is indicated in Appendix-3.1. Further, in "Recommendation for Enhancing Reactor Safety in the 21st Century" compiled by US NRC task force as a report of investigation and review on the accident in Fukushima Daiichi Nuclear Power Station, 12 recommendations are listed including the requests to regulatory bodies. We also made comparison with these recommendations and listed the comparison result in Appendix-3.2 to identify any additional issues to be addressed.

## Comparison with the training of 28 items of Government Report to IAEA and the measure against this report on the first nuclear power plant accident of appendix-3.1 Fukushima

Group name	Items	Contents	Additional requirements in attachment data	Comparison with the measures of this report
The preventive measure of a severe accident	(1) Measure tempering to an earthquake and tsunami	<p>This earthquake was a very large-scale earthquake due to the interlocking of multiple epicenters. As a result, in the first nuclear power plant of Fukushima, the acceleration response spectrum of the earthquake motion observed on the reactor building basic board exceeded with some periodic belts as against to the acceleration response spectrum of the basic earthquake ground motion of a design. Due to the earthquake, damage was observed for external power source.</p> <p>Although the major damage caused by an earthquake is not checked for important facility to safety or important safety related equipment. Detailed situation is still not known and further investigation about it is required.</p> <p>The assumed height of the Tsunami that struck the Fukushima nuclear power station, was exceeded to a large scale of 14~15m against the construction permit design and valuation. As a result of this tsunami there is major damage to sea water pumps etc., and cause of this damage is due to the non- possibility of assurance / reservation of emergency diesel power supply and assurance/ reservation for reactor cooling function. In the manual, intrusion of tsunami was not assumed but only the measures against an undertow were defined. Thus, assumption of the generating frequency of tsunami or height is insufficient, and correspondence against extensive tsunami attack is insufficient.</p> <p>From the view point of design, in the nuclear power station for the aseismic design, range of activity period of active fault is considered within 120000~130000 years (as per the old guidelines it is 50000 years. Recurrence cycle of a big earthquake and residual risk should be considered. On the other hand, the design to tsunami is performed based on the past tradition and clear trace of tsunami. For attaining safety objectives, there were no efforts by considering appropriate recurrence cycle.</p> <p>Due to this, while assuming earthquake, multiple epicenters interlocking should be considered and at the same time external power source resistance should be improved. About tsunami, the suitable generating frequency of the tsunami in consideration of sufficient recurrence cycle for achieving a safety objective and sufficient height are assumed from a viewpoint of preventing a severe accident. For the tsunami having appropriate height, safety design of construction which prevents flood influence on the site, should be executed with consideration of destructive ability of that Tsunami. From the view point of defense in depth, risk existence should be recognized by observing exceeded tsunami's coverage on site as against planned design for tsunami. Counter measures that can preserve important safety functions should be taken by considering site flood or destruction ability of running wave.</p>		<p>About evaluation of an earthquake and tsunami, the following evaluation conditions are added based on the knowledge acquired from this data.</p> <ul style="list-style-type: none"> <li>As per the present view, Ss measures for standard earthquake are considered to be an almost satisfying decision, in order to be assure further safety, interlocking of two or more epicenters should be considered.</li> <li>After the valuation of Tsunami expected as per earthquake, consideration should be done for interlocking of multiple epicenters as wave source at plate barrier and, examine the necessity of setting sliding quantity of epicenter fault, on a large scale.</li> </ul> <p>Related to the external power supply, on the basis of NISA direction document [About reliability reservation of the external power supply of a nuclear power plant and a reprocessing facility], the measure (circuit connection, tower tempering, measure against switching station flood) for reliability reservation is performed.</p> <p>Valuation of assumed tsunami height is done and, prevention should be done against intrusion of tsunami within site. Moreover, following multi level counter measures should be performed. Assurance of functions of safety installation should be finalized.</p> <p>Counter measures should be performed against the attack of the tsunami inside site. Examples are as follows.</p> <ul style="list-style-type: none"> <li>Care should be taken for the equipments of safety important power source installations. While preparing for the flood by tsunami, coastal levee (storm surge barrier) or breakwater should be installed, or from the view point of multilevel security, protection barrier should be installed in the important system.</li> <li>Protection to tsunami, such as a tank which may serve as flotsam and may interfere with emergency correspondence (protective barrier etc.). Disposition of the heavy industrial machine for flotsam removal.</li> </ul> <p>Moreover, counter measures should be taken for preventing intrusion within the building. Illustrative examples are as follows.</p> <ul style="list-style-type: none"> <li>Regarding to the Tsunami which exceeds site height, as per the flood height, tsunami preventive measures such as improvement of the external gate of the building or the sealing of air supply opening and penetration should be executed.</li> </ul>

Group name	Items	Contents	Additional requirements in attachment data	Comparison with the measures of this report
				<ul style="list-style-type: none"> <li>• Regarding to the Tsunami which exceeds site height, for the flood prevention of safety important installations, counter measures should be improved for water tightness of the ground stage gate and the gate which is passes through the main ground stage.</li> <li>• For early re-establishment, portable water discharging pumps should be deployed in building for discharging entered flooded sea water.</li> <li>• Regarding to the impact of wave power of tsunami, attention should be paid to the places where direct impact of tsunami is observed.</li> </ul> <p>Moreover, tsunami counter-measures should be taken against seawater pumps.</p> <p>■Written part in this report is 4.6 Preparation against earthquake · tsunami</p> <p>■Counter-measure Examples Preparation against earthquake tsunami (1)~⑨</p>
	(2) Power source assurance	<p>The major factor of this accident is that a required power supply was not assured. This cause indicated that the, power supply diversity is not done so as to overcome vulnerability for common cause failure due to the external events; setup of power board etc. was not good so as to bear severe environment. Moreover, battery life ended till the returning of AC source, it indicates that the, objective of battery is not clear. Time needed till the restoration of external power source was not known properly.</p> <p>For this, power supply can be assured for a long time in severe situation, by installing multiple power air cooled diesel generator, combustion turbine etc, planning for the diversification of power source by deploying of power source car, distributing frame having high environmental tolerance installation of battery charging generator.</p>	<ul style="list-style-type: none"> <li>• For external power supply reception, from the view of reliability improvement, counter-measures such as connection of each machine and all power lines, transmission tower (power lines) switch yard soaking etc. were indicated.</li> <li>• Entrepreneur is asked about the measure required for the power supply reservation in an emergency. These measures are such as, assurance of high capacity of rechargeable battery or battery charging from the existing backup power source, safety important equipment or power supply boards having Higher evaluation so that entire functioning will not be lost by flood · decentralized geometry which can be installed on height, earthquake-proof tempering of switching station equipment, maintenance of the organization which supplies fuel oil required for backup power reservation etc.</li> </ul> <p>【2011.9.11 attached Government Report】 As a future measure, rechargeable battery having high capacity or earthquake-proof tempering of the fuel tank of backup power, etc. are planned.</p>	<p>From the view point of power source assurance, external power supply should be assured, and when it is useless, equipment should be installed for supplying power from DG in emergencies. However, these preparations carried out loss of function this time.</p> <p>Therefore, the reliability of an external power supply should be improved.</p> <p>① External power supply is based on the NISA directions [reliability reservation of the external energizer of a nuclear power plant and a reprocessing facility.] and, it is corresponding to the measures (line connection, steel tower strengthening, and measure against switching station flood) for power source reliability assurance.</p> <p>Following details are based on the assumption, when emergency DG functioning is failed.</p> <p>(2)As backup power supply of emergency DG for emergency, diversification of power source should be done by power source car or high capacity power source installation (including necessary fuel). Regarding power panel, preparations are done for tsunami attack by tsunami counter-measures. Moreover, the power source car is installed on the heights which are not subject to tsunami influence. Separate consideration is done for direct power supply and measures at the time of loss is also considered.</p> <p>(3)Rechargeable battery reserves charge route from power source car and it is prepared for tsunami attacks with flood measures.</p> <p>Reliable power supply reservation is achieved by these multilevel measures.</p> <p>■Written part in this report</p>

Group name	Items	Contents	Additional requirements in attachment data	Comparison with the measures of this report
	(3) Assurance of secured cooling function of reactor and containment	<p>In this accident, as per the function loss of seawater pump, last heat escaping place (last heat sink) is lost. The nuclear reactor cooling function is operated by injection, but depletion of water source for injection or prevention of core damage due to the loss of power was not possible. Container cooling function was not operated properly. After that, reactor decompression also will take time. As an accident management counter-measure, for the reactor injection, installation of heavy machines like fire truck was not done for the injection after decompression. In such a way reactor and container has lost cooling functionality and, aggravation of accident has increased.</p> <p>Due to this, alternate cooling function of reactor or container should be assured by the diversification of an alternative injection function, diversification of water source for injection or increase of capacity, introduction of an air cooling system, and assurance of an alternate long lasting heat sink.</p>	<ul style="list-style-type: none"> <li>Entrepreneur is asked about the necessary measures required for the reservation of means of injection. Intake pit or large raw water tank Reinforcement against earthquakes, countermeasures necessary for water source assurance of injection to reactor and container or, check reinforcement against the component of containment spray ring, Installation of pump for absorption of reservoir or seawater pit or, pump which can perform external injection to reactor which is not requiring power supply and steam generator, Maintenance of injection equipment (example: DG drive pump, high-pressure piping, etc.), etc.,</li> <li>The entrepreneur is asked also about the necessary measures which are required, for the assurance of the heat sink used for removing decay heat and components. These measures are such as an intake pit installation for cooling in seawater, disposition of intake pump spare parts, diversification of a intake parts, Development and maintenance of an air-cooled system etc.</li> </ul> <p><b>【2011.9.11 attached government report】</b> As a future measure, earthquake-proof strengthening of a large-scale fresh water tank etc. is planned.</p>	<p>4.7.1 Complete blackout and direct power source loss</p> <p>■Counter-measure examples Preparation of power source (1)~⑥</p> <p>In this accident, external power supply lost due to the earthquake and the seawater pump was flooded by tsunami, it resulted in complete blackout and loss in seawater functioning. Regarding RCIC, HPCI, IC, reactor core cooling system can be used at the time of complete blackout, but this functionality is lost due to the loss or depletion of direct power supply.</p> <p>For this reason, the following measures are considered as an example of measure. And these measure examples can be considered as multilevel measures by combining them with the conventional equipment.</p> <p>① Injection cooling function reservation of reactor is corresponding to the assurance of injection means to reactor, by portable power pump which is not present in existing power source, assurance of water source for injection having seawater, assurance of backup driving source necessary for SRV operations because during injection, secured reactor decompression is necessary for SRV etc.</p> <p>(2)It corresponds about assurance of the last heat sink by the sea water system restoration by early restoration of a seawater pump, or spare-parts disposition.</p> <p>(3)Assurance of alternate last heat sink is corresponding with escaping of in atmosphere through containment vent.</p> <p>■Written part in this report 4.8.1 Injection to reactor 4.8.2 Seawater cooling loss</p> <p>■Counter-measures example Heat sink loss correspondence (1)、(2)、⑧~⑩</p>
	(4)Assurance of secured cooling function of used fuel pool.	<p>This time, since cooling of the used fuel pool became impossible by loss of the power supply, in parallel to accident correspondence of a nuclear reactor, the correspondence which prevents the severe accident by the cooling function loss of a used fuel pool is also necessary. Until now, risk of major accident of used fuel pool was considered minor compared with the risk of reactor accident. Because of this, measures like alternate injection etc. are not considered.</p> <p>For this reason, at the time of power supply loss, secured cooling is assured by introducing the alternative cooling function of a natural circulation cooling system or an air cooling system, and alternative injection function so that cooling of a used fuel pool can be maintained.</p>	<p>The entrepreneur is asked about the measure required for assurance of the secured cooling function of a used fuel pool such as, earthquake-proof strengthening of cooling system piping of a spent fuel storage pool, assurance of the power supply from emergency power source to the water gauge and thermometer of a used fuel pool, Strengthening of check of the cooling pump etc. of a used fuel pool,, Strengthening of the condition monitoring of a used fuel pool (ITV etc.),introduction of dry cask storage, etc.</p> <p><b>【2011.9.11 attached government report】</b> As a future measure, earthquake-proof strengthening of cooling piping of a used fuel</p>	<p>For assurance of the secured cooling function of a used fuel pool, maintenance of water level is very important when cooling function is lost, used fuel should not be exposed. For that purpose, assurance of an alternative injection means is important. For example, assurance of injection with fire truck/pump car and assurance of corresponding injection route and water source.</p> <p>Moreover, in order to check the validity of an alternative injection measure, enhancement of the monitoring function of pool water level and pool water temperature is also necessary. For example, power source supply to level instrumentation and thermometer or status monitoring enhancement of pool using ITV etc. of battery drive measures should be considered.</p> <p>Thus, there is possibility of securing the soundness of used fuel by performing injection to a used fuel pool and maintaining</p>

Group name	Items	Contents	Additional requirements in attachment data	Comparison with the measures of this report
			pool, etc. are planned.	<p>pool water level. For further improvement in reliability, it is mentioned as an example of a measure also for the policy which maintains a cooling function.</p> <p>■Written part in this report 4.11 Soundness assurance of used fuel</p> <p>■Measure example Soundness assurance of used fuel (1)~(3)</p>
	(5)Accident management (AM) measures compliance	<p>This accident results in a severe accident. For minimizing the possibility of severe accident or mitigating the influence of severe accident, the accident management measures are introduced also in the Fukushima nuclear power plant. From the view point of this accident situation, part of alternate injection of reactor from the Fire Working Water System was working, and various correspondences of power source or reactor cooling function assurance were fail and accident management measures were insufficient. Moreover, it was fundamentally considered as the entrepreneur's independent measure, and the demand for laws and regulations was not carried out, but maintenance contents were lacking. Furthermore, accident management guidelines were designed in 1992,and they are not reexamined, improved and reinforced.</p> <p>For this reason, accident management measures are performed for preventing severe accidents effectively and efficiently. These measures are, self control safety precautions are re-modified by an entrepreneur. This is done on the demand of laws and regulations. Probabilistic valuation techniques are applied. Design requirement items are re-modified.</p>		<p>About the state of regulation, it is jurisdiction of a country and as a subject it is not raised in this report of industrial world.</p> <p>However, the validity of PSA use would be recognized from this accident, and here onward use of PSA will be considered.</p> <p>About the example of measure, measures are examined in multiple ways. Handling of valid measures regarding the severe accident measures such as preventing outbreak of accident, is strongly recommended in [4.5 chapter measures collection].</p>
	(6) Correspondence to the subject for multiple furnaces.	<p>In this accident, the accident occurred simultaneously at multiple furnaces, and resources required for accident correspondence distributed. Moreover, as two nuclear reactors are having shared equipments or the physical interval between them was very small, etc., emergency correspondences of adjoining reactor was affected by the progress of one reactor accident</p> <p>for this reason, when multiple nuclear reactors are located in one plant, and in case accident occurred in one reactor, operations of other reactor should be separated and executed independently. Also, Engineering independency of each nuclear reactor should be ensured and care should be taken so as, impact of reactor under accident should not extend till adjoining reactor. Moreover, it is recommended that, chief person should be assigned for reactor safety assurance and he should execute independent accident correspondence.</p>	<p>The entrepreneur is asked about the necessary measures for the correspondence for the subject in the location of same site of majority basis, assurance of issue period necessary for safety assurance, thoroughness isolation of building period, assurance (Rationalization of arrangement of a reactor building and a turbine building) of the engineering independency in the location of multiple units etc.</p> <p>【2011.9.11 attached government report】 Hereafter the verification of the policy for making engineering in-dependency, of each nuclear reactor in multiple furnace locations in a more positive way, is scheduled.</p>	<p>At present, the level or problem of influence to concrete accident correspondence by multiple furnace location, are not in sight other than the influence on work with the affair in which the hydrogen which occurred at No. 3 started surroundings lump explosion from the exhaust line to No. 4, and the contiguity number machine by hydrogen explosion. If the information more than the former about multiple furnace location will come out in the process of accident investigation here onward, consideration can be done that examination of a concrete measure is advanced. For the time being, training will be conducted by considering occurrence of a simultaneous accident at two or more furnaces. In it, reexamination of a procedure, the necessity for reexamination of staff disposition, etc. are checked.</p>
	(7) Consideration on basic designs of nuclear power plant arrangement.	<p>This time, the difficulty generated in accident correspondence, as the used fuel pool was located in the high position of the reactor building. Moreover, the contaminated water of the reactor building was not able to prevent expansion of the contaminated water between a turbine building and a building.</p> <p>For this reason, even though occurrence of a serious accident is considered in basic design like an arranging nuclear power generation institution, hereafter cooling etc. can be carried out certainly., and suitable arrangement of the institution and building which can prevent expansion of the influence of an accident is advanced. In that case, the additional measure for having an equivalent function is taken against the existing institution.</p>	<p>The entrepreneur is asked for rationalization of arrangement of a reactor building and a turbine building, etc.</p> <p>【2011.9.11 attached government report】 Materialization of examination is planned by considering the institution of a nuclear power plant, suitable arrangement of a building, etc. in the basic design for nuclear reactor establishment etc.</p>	<p>In an establishment plant, about arrangement of apparatus, designing should be done in such a way that it reflects this accident perception. For the existing plant, following concrete examples of a measure are raised for filling the gap between ideal conditions and present conditions.</p> <p>It is necessary to think on counter measures in case of examining injection route to used fuel pool, and when pool is at natural height.</p> <ul style="list-style-type: none"> <li>Injection of water by fire truck, pump truck etc, as well as water injection route and water source should be ensured.</li> </ul>

Group name	Items	Contents	Additional requirements in attachment data	Comparison with the measures of this report
				<p>The counter-measures such as the isolation from water for the compartments or breakwater or sealing the opening, should be carried out with respect to the installation location or installation conditions.</p> <ul style="list-style-type: none"> <li>• Build sea wall as well as breakwater, also build protective wall for important installations.</li> <li>• Evaluate the tsunami impact in case of site height exceeding, building outdoor, air supply opening aperture &amp; penetration with respect to flood height, implement flood prevention counter-measures related to seal improvement etc</li> <li>• Evaluate the tsunami impact in case of site height exceeding and perform counter measures like flood prevention of safety equipments, improve isolation from water of openings leading to basement and basement openings and limit the impact of flood</li> <li>• Deploying portable drainage pump to drain sea water inside the building for early restoration</li> <li>• Have consideration of tsunami wave impact power in case of sea facing door etc have chances of direct tsunami impact.</li> <li>• Have flood prevention measure like water prevention wall around sea water pump.</li> <li>• Deploy motor spare parts for early restoration &amp; implementation</li> <li>• Deploy movable sea water pump or waterproof pump installation</li> </ul> <p>■Items mentioned in this report</p> <ul style="list-style-type: none"> <li>4.6.2 Tsunami flood prevention within the premises</li> <li>4.6.3 (1) Waterproofing of important facilities</li> <li>4.6.3 (2) Flood counter-measures of sea water system</li> <li>4.11 Ensure soundness of spent fuel</li> </ul> <p>■Counter-measures</p> <ul style="list-style-type: none"> <li>Provisions against earthquake · tsunami (1) – (2)</li> <li>Ensure soundness of spent fuel (1) – (2)</li> </ul>
	(8)Ensuring Waterproofing of important facilities	<p>One of the reason of this times accident was, lot of important equipment facility like sea water pump facility for auxiliary cooling, Emergency Diesel Generator, switchboard were flooded in the tsunami, As a result there were difficulties in ensuring electricity supply and cooling system.</p> <p>As a result from the viewpoint of achieving objective level of safety, tsunami exceeding the design time assumption. Ensure necessary safe functionality even in case of flood striking due to exceeding design time assumptions of river side adjacent location. Basically, installation of doors based on destructive force of tsunami or flood, blocks in the piping or flood pathway, using emergency water pump installation, ensuring water proofing of important equipment facility</p>	<p>Moving and distributing important safety equipments to upper floor or upland, demanding the counter measures to ensure water proofing of important facilities to the operators.</p>	<p>For Tsunami, Firstly doing scientifically reasonable assumptions to evaluate tsunami height , For that 1 [ensure necessary sight height] is the top priority counter measures. But from multi layered protection viewpoint , considering assumptions for the case of the attack of tsunami exceeding site height, In case push force of tsunami is more powerful then investigation of avoiding destruction of important safety facility.</p> <p>Considering the importance 2. Perform defense of breakwater etc, moreover, assumptions based on tsunami height being exceedingly high, places where the sea water can infiltrate like building aperture, pathways places where equipments loss of function can occur. 3. Counter measures like Installation of</p>

Group name	Items	Contents	Additional requirements in attachment data	Comparison with the measures of this report
				<p>waterproof doors, Sealing of apertures etc. Also making assumptions that prevention can not be done at building infiltration and doing important safety to each instrument. 4. Doing waterproofing of each compartment, ensure the safety functions, more over, still if the water enters water proof compartments necessary assumptions to be done. emission of flooded water as early as possible 5. Deploy emission pump. Again, about emergency light etc 6. In case of tsunami reaching, crossing upland and also moving in, and impacts certainly and the existing power supply fails, in that case back up is expected to work.</p> <p>Like this multi layered counter measures counter measures for tsunami attack. Assuming these counter measures, power supply failure or heat sink failure and other common factored failures or functionality failures prevention and expansion of certain accident prevention.</p> <p>■Items mentioned in this report  4.6.2 Flood prevention from tsunami within the premises  4.6.3 flood prevention measures for building  4.7.1 Complete loss of AC power supply and loss of DC power supply</p> <p>■counter-measures  Provisions for earthquake · tsunami 1-3, 5  Power supply preparation 1-3, 5, 6  Heat sink failure measures 12</p>
Responding to incidents in severe accident	(9) Reinforce the counter-measures for prevention of hydrogen explosion.	<p>In case of the present accident, it was seen that there was hydrogen explosion in each of unit 1 of nuclear reactor building at 15:36 on March 12, and in unit 3 of nuclear reactor building at 11:01 on March 14. Moreover, there was an explosion which seemed to be due to hydrogen in unit 4 at 15:06 on March 15.</p> <p>That is, no help can be received from the initial explosion for unit 1 and the conditions were such that the explosions occurred in continuation, and that was a major thing in case of the present accident. In order to maintain the soundness of the containment vessel in boiling water reactor, as per the design standards, inner part of containment vessel was inactivated, and burnable gas control system is setup. However, it was not assumed that there will be leakage of hydrogen gas in the nuclear reactor building and will lead to conditions that can create explosion, hence, hydrogen counter-measures were not implemented in nuclear reactor building.</p> <p>Hence, in order to precisely reduce the escape of generated hydrogen should, along with the hydrogen related counter measures for containment vessel, it is necessary to reinforce the hydrogen explosion prevention counter-measures for burnable gas control system setup in nuclear reactor, which is used in case of severe accidents and completion of facilities in order to escape the hydrogen outside.</p>	<ul style="list-style-type: none"> <li>With respect to BWR, it is demanded that the implementation of decision and practice of measures with an objective of hydrogen explosion prevention and blowout panel opening means should be ensured. For BWR, implementation of the measures for prevention of hydrogen accumulation in the burnable gas control system in nuclear reactor building, is demanded. Based on the analysis of the conditions which occurred in Fukushima Daiichi (leakage), the important counter-measures such that hydrogen detector device within the building or setup in nuclear reactor building for hydrogen vent etc should be reinforced.</li> <li>For PWR, the power supply for the annulus exhaust system for the electric car for escape of the hydrogen at the time of leakage, power supply for the igniter for the electric car (hydrogen ignition device) should be ensured. The important counter-measures such as the installation of passive catalytic</li> </ul>	<p>Based on the design standards up till now, with respect to the hydrogen which can generate due to acid reaction of nuclear reactor coolant with fuel cladding tube, it is done such that there is prevention of hydrogen generated by reactor cooling by emergency reactor cooling system or in case of boiling water reactor (BWR), the deactivation is done due to nitrogen inclusion in nuclear reactor containment vessel and hence even if hydrogen leaks by some chance, the atmosphere inside the nuclear reactor containment vessel remains below combustible limits.</p> <p>However, in case of BWR, due to circumstances which were out of design conditions, there was hydrogen leakage from the same container to the inside of the nuclear reactor building. For this, (1) [the counter-measures for releasing the hydrogen stagnated in the nuclear reactor building etc or reducing its concentration]</p> <p>(2) [Based on the analysis of path where hydrogen leakage had occurred, setting up of the hydrogen gas detector system, which will carefully monitor the accumulation of hydrogen gas inside the nuclear reactor building] are proposed.</p> <p>Moreover, in order to prevent the collection of hydrogen inside the nuclear reactor building, at the time of containment vessel venting corresponding to severe accident, the following counter-measures : (3) [In case junction is present in the</p>

Group name	Items	Contents	Additional requirements in attachment data	Comparison with the measures of this report
			<p>hydrogen supply device on containment vessel should be reinforced.</p> <p>[Refer 2011.9.11 government report] About the mid-range efforts hereafter</p> <ul style="list-style-type: none"> <li>For BWR, it is planned that the hydrogen vent device should be setup at the top of the nuclear reactor building. Hydrogen detector should be setup inside the nuclear reactor building. For PWR, it is planned to set up a device which will reduce the concentration of hydrogen inside the containment vessel of passive catalytic hydrogen reunion device etc , which does not use power supply.</li> </ul>	<p>containment vessel vent line, prevention of circulation of hydrogen from that exhaust pipe]</p> <p>(4)[Prevention of circulation of hydrogen in the other units sharing this exhaust pipes] are proposed and the prevention of accumulation of hydrogen inside the nuclear reactor building is done as shown in the diagram.</p> <p>Thus, the explosion due to hydrogen accumulation in the nuclear reactor building is prevented by implementing these counter-measures and the severity of the accident can be prevented.</p> <p>Furthermore, if the counter-measures for prevention of generation of hydrogen are certainly implemented, it is possible to prevent hydrogen explosion, and the setup of burnable gas control system inside the nuclear reactor building for BWR is not essential.</p> <p>■Items mentioned in this report 4.9 hydrogen counter-measures</p> <p>■Examples of counter-measures Hydrogen counter-measures (1) ~ (4)</p>
	(10) Reinforce of containment vessel vent system	<p>In this times accident, at the time of occurrence of severe accident there were problems in the operability of containment vessel vent system. Also containment vessel vent system could not handle functionality of radioactive substance removal management, hence accident management could not make effective use of counter measures. Also could not do the isolation of vent line hence due to connecting pipes etc there was a chance of bad impact on other areas.</p> <p>Hence here after, it will be ensured to have independent operability of containment vessel vent system. reinforcing of radioactive substance removal management and hence reinforcing of containment vessel vent system</p>	<ul style="list-style-type: none"> <li>Installation of Filter etc at vent, design of rupture disk, evaluation of operating condition or review, installation of accumulator at vent AO valve, independence of vent exhaust line which was assumed at accident, reinforcing leakage prevention at adjacent Unit, seeking necessary counter measures at reinforce of containment vessel vent to the operator.</li> <li>[2011.9.11 Government Report] By doing the broader study of domestic technical knowledge, reinforce radioactive material and work out reinforcement of containment vessel vent system</li> </ul>	<p>Contentment vessel vent has post accident over pressure prevention and heat release functionality as severe accident counter measures. To ensure the actual vent functionality, as line configuration counter measure 1. Preparation for existing source failure, ensuring necessary backup for operation of containment vessel vent valve (driving source - electricity / Pump)</p> <p>2. [Optimization of operating conditions for vent] Investigation about leakage prevention to adjacent unit through exhaust line (wrap around).</p> <p>3. Moreover, after the core damage of containment vessel investigation of counter measure of cooling using substitute spray.</p> <p>■ Items mentioned in this report 4.8.3 containment vessel vent 4.9 hydrogen counter-measures</p> <p>■Counter measures Measures for heat sink failure 3 - 5 Hydrogen counter measures 3</p>
	(11) Strengthening the environment corresponding to the accident	<p>At the time of this accident, the radiation dose of the central room was increased, once the conditions were such that the operators could not even enter and it was difficult to do work for a long time, and hence presence in the central control room was reduced a lot. Moreover, the radiation dose rose even in nuclear power station emergency station which becomes central location for emergency counter-measures implementation. It became more and more difficult to perform the activities corresponding to this accident due to worsening of communication environment or illumination conditions,</p> <p>Hence, the protection of central control room or emergency station from the radiation, exclusive air heating and ventilating system on the site should be reinforced. The communication which will not depend on AC power supply, setup pf</p>	<ul style="list-style-type: none"> <li>Ensure that the emergency power supply is available for in campus PHS communication system, ensure communication tools such as transceiver etc., ensure portable illumination device, maintaining radiation shielding function of central control room corresponding to air heating and ventilating system installation for emergency electric supply car and completion of such infrastructure of the environment corresponding to the accident</li> </ul>	<p>For livable conditions inside the central control room, setup of central control room ventilation fan containing charcoal filter for leaving behind raw materials and while designing shielding, ensuring that the conditions are livable even at the time of accident is done.</p> <p>However, due to complete loss of AC power supply the central control room ventilation fan containing charcoal filter for leaving behind raw materials could not function and hence, the following counter-measures (1)[ Ensure the availability of power supply to the central control room ventilation fan so as to perform functions in case of emergency. Moreover, complete</p>

Group name	Items	Contents	Additional requirements in attachment data	Comparison with the measures of this report
		<p>illumination systems should be reinforced. Even if severe accident occurs, the activities corresponding to the accident should be able to be continued and such an environment should be reinforced.</p>	<p>situation etc is demanded.</p> <ul style="list-style-type: none"> <li>Reinforcement of communication system (diversification of electric supply etc) and reinforce the functions of emergency room (ensure isolation, shielding, important personnel skills etc) The aseismic reinforce for administration building, countermeasures to reinforce the environment corresponding to accident should be implemented.</li> </ul> <p>[Refer 2011.9.11 government report]  Along with shifting the PHS etc devices within the site, to higher elevation, reinforcing the functions of emergency counter-measure building or aseismic reinforce of administration building is planned.</p>	<p>the operation procedures for this.]</p> <p>Also, (2) [Investigate the main cause for rise of radiation dose in the central control room, reinforce the counter-measures for radiation protection of the central control room] are proposed.</p> <p>Hence it is possible to improve the environment corresponding to the accident, by implementing the counter-measures for improving the livability of the central control room at the time of accident.</p> <p>Regarding communication system, which is an important device for support in unusual conditions of class 3 importance classification, it is ensured that the authenticity is maintained at least equal or above the general industry facility.</p> <p>However, if natural phenomenon much beyond the assumptions occur, similar to this time, it is feared that such communication systems become unusable and hence regarding communication facility within the power plant as well as with the outside, the following counter-measures</p> <ol style="list-style-type: none"> <li>Ensure a self reliant backup supply system which is not affected by earthquake, tsunami etc.</li> <li>Implement the facilities such that they are not cut off easily due to earthquake, tsunami etc.</li> <li>Deploy multiple means of communication Are proposed.</li> </ol> <p>Also, from a viewpoint that the information sharing with the actual site should take place smoothly at the time of accident</p> <ol style="list-style-type: none"> <li>Necessary number of communication devices should be set up including the actual site.</li> <li>It is proposed that the counter-measures such as mastering the operation by conveying the definition of the method of practical use and practice etc.</li> </ol> <p>Such important counter-measures for maintaining the environment at the time of accident have been proposed and because of these counter-measures, the communication within the power plant as well as with the outside is maintained even if unusual natural phenomenon exceeding all the assumptions occur.</p> <p>Emergency station は, In case of complete loss of AC power supply for long duration in case of severe natural phenomenon, such as earthquake or tsunami etc and severe conditions such as release of large amounts of radioactive material in the environment, the functions of emergency station become important, hence arrangements should be made such that these functions should be successful after assuming these conditions.</p> <p>Hence, (1) the structure should be resistant to the earthquake or tsunami.</p> <ol style="list-style-type: none"> <li>Ensure an emergency power supply system which is independent from the plant.</li> <li>Ensure monitoring important plant parameters and</li> </ol>

Group name	Items	Contents	Additional requirements in attachment data	Comparison with the measures of this report
				<p>means for communication with the central control room, actual site.</p> <p>(4)Radiation protection counter-measures.</p> <p>(5)Taking into consideration the things such as ensuring livability of necessary person corresponding to emergency conditions and that of important materials and equipments, complete the emergency station.</p> <p>Regarding the emergency station, all the aspects are extensively considered, if the environment corresponding to the accident is reinforced by implementing these countermeasures, the activities corresponding to the accident can be carried out smoothly.</p> <p>■Items mentioned in this report  4.10.2 Central control room air conditioning, shielding  4.10.7 Communication  4.10.4 Emergency station</p> <p>■ Example of counter-measures  Arrangements for emergency situations. (6), (7),(13), (22)~(28),(30)~(33)</p>
	(12) Reinforcement of radiation exposure administration system at the time of accident	<p>In this time accident, there were lots of individual dosimeters or radiation reading devices immersed in water and become unusable. Hence adequate radiation measurement control was difficult; personnel engaged in radiation work were difficult to get to the site. Also in air radioactive material measurement was also delayed.</p> <p>Risk of internal exposure was increasing.  Hence individual dosimeter or radiation protection equipment at the time of accident should be kept in abundance. At the time of accident, system of expansion of radiation control personnel to be done. Radiation control workers' exposure measurement should be fast.</p> <p>Radiation exposure control system should be reinforced at the time of accident instead of just fast moving system or equipment completion system.</p>	<ul style="list-style-type: none"> <li>• Ensure seeking of more individual dosimeter based on no of people at emergency work at the time of accident</li> <li>• Seek system completion for expandable radiation control personnel at the time of accident.</li> </ul>	<p>Based on this times accident, in case of severe accident occurrence, support activities need to be done in high radiation environment. There could be a situation in which radiation control may become essential in area where in normal time radiation control not required. Considering the factor of severe accident, severity of natural phenomena, power failure of power plant, can lead to considerable confusion.</p> <p>In such kind of situation, adequate personnel doing radiation control to prevent excess radiation, to report 1. Necessary equipment need to be ensured at radiation control. 2. Ensure adequate radiation control personnel. 3. Policy to avoid unwanted radiation exposure is under proposal.</p> <p>Basically about 1, considering complete power failure, preparation of radiation measurement instrument, accommodating the radiation measurement instrument for alternate power source, based on accident review the no of protection equipments, 2 is about, completion of radiation control support system, 3 is about information sharing on radiation etc.</p> <p>Apart from these counter-measures, the completion of emergency station which has taken measures for radioactive protection, as a completion of support environment at the time of accident, is demanded, also, it is pursued to take measures to prevent each type of accident and furthermore, considering occurrence of accident and then taking counter measures to reduce radiation exposure</p> <p>■Items mentioned in this report  4.10.5 Radiation control / Work management</p> <p>■Example of counter-measures  Preparations corresponding to emergency (1) ~ (5)</p>

Group name	Items	Contents	Additional requirements in attachment data	Comparison with the measures of this report
	(13) Reinforce practice for dealing with an accident	<p>In case of severe accidents, to deal with nuclear power station accidents, effective practice for implementing convergence of related facilities was not much in place till now. For e.g., this time, at the time of accident, time was needed to establish cooperation between Nuclear Emergency Response Headquarters, local nuclear emergency response headquarters and emergency station inside the power plant, cooperation between self defense force, police, fire department etc which play an important role in dealing with an accident, it is possible to prevent it by implementing precise practice regarding these points also.</p> <p>Hence, in case severe accident occurs, then, to smoothly carry out emergency assembling of skilled persons for dealing with an accident, and to ensure the understanding of the conditions that occur inside and outside of the power plant and safety of citizens, practice should be done regarding how to deal with severe accident.</p>	<ul style="list-style-type: none"> <li>• It is pursued that workers should carry out the practice to deal with emergency conditions with assumptions of occurrence of severe accident due to short time breaking of coolant material etc, as well as its prolonged duration and severe conditions.</li> <li>• Important counter-measures are demanded from the workers regarding practice for dealing with terrorism.</li> </ul> <p>[Refer 2011.9.11 Government Report]</p> <p>The country will seek that workers should carry out the practice to deal with emergency conditions with assumptions of occurrence of severe accident due to short time breaking of coolant material etc, as well as its prolonged duration and severe conditions.</p>	<p>It is assumed that, when the severe accident takes place, then the activities to deal with the accident are mainly focused on various operations on the actual site, also the operations on actual site are executed under severe working conditions assumptions and hence, following counter-measures</p> <ol style="list-style-type: none"> <li>(1) The knowledge and abilities required from each necessary person should be sorted out and practice should be done based on this.</li> <li>(2) Execute practice of activities on actual site related to accident management.</li> <li>(3) It is proposed to execute counter-measures by carrying out practice in modeled severe conditions such as night time work, heavy equipments etc.</li> </ol> <p>Also, in order to be able to properly deal with events as they progress, it is proposed that the counter-measures as below should be executed:</p> <ol style="list-style-type: none"> <li>(4) High level executions such as blind practice, real time practice etc is carried out.</li> <li>(5) Accessing the actual site or prior confirmation of the required time for the actual work</li> <li>(6) Practical usage of simulator etc,</li> </ol> <p>Thus, without forgetting the lessons learned this time, accident management practice at the time of occurrence of severe accident should be completed and carried out continuously; due to which it is thought that it is possible to perform activities much more smoothly to deal with accident.</p> <p>Moreover, there is a plan to conduct investigation afterwards regarding the nuclear reactor emergency practice to be executed by the country as well as self governing organizations, but the workers should deal appropriately on the basis of this analysis result and should cooperate positively.</p> <p>■ Items mentioned in this report 4.10.1 Practice</p> <p>■ Examples of counter-measures Arrangements related to emergency (14) ~ (19)</p>
	(14) Reinforce the instrumentation system of nuclear reactor as well as containment vessel	<p>It was difficult to ensure important information such as water level or pressure of nuclear reactor, source of release of radioactive material, release quantity quickly and accurately, if the instrumentation system of nuclear reactor and containment vessel does not work under severe accident conditions.</p> <p>Hence, reinforce the instrumentation system of the nuclear reactor and containment vessel which performs sufficient functions at the time of severe accident.</p>	<ul style="list-style-type: none"> <li>• It is demanded that the business operators should reinforce development as well as completion of instrumentation system of nuclear reactor and containment vessel, which performs sufficient functions at the time of severe accident, and that of spent fuel pool and the instrumentation system for understanding the situation.</li> </ul> <p>[Refer 2011.9.11 Government Report]</p> <p>Planning the preparation and development of the instrumentation system of the nuclear reactor and containment vessel which performs sufficient functions at the time of</p>	<p>Regarding the instrumentation system of the nuclear reactor and containment vessel, inspection within the estimated scope for fluctuations was possible till now; irrespective of taking measures at the time of accident after knowing about the accident, the design is capable of monitoring important parameters by distributing over a sufficient scope using proper methods and</p> <p>However, the supply of the meter is lost due to loss of functionality of DC power supply system and total loss of AC power supply for long duration, the important parameters, the measurement or recording of important parameters was not possible and hence, the following things</p> <ol style="list-style-type: none"> <li>(1) [Install temporary storage battery or connection cable in the vicinity of central control room for electricity backup.]</li> </ol>

Group name	Items	Contents	Additional requirements in attachment data	Comparison with the measures of this report
			<p>severe accident as well as instrumentation system of spent fuel pool.</p>	<p>(2)[Reconsider conservation of electric power of the meter or non failure of electricity as per requirement] are proposed.</p> <p>Also, under the conditions at the time of occurrence of severe accident, it was not assumed that there will be circumstances which lower the range of measurement of the water level meter and hence, the following measure is proposed.</p> <p>(3)[Consider the occurrence of severe accident, development of the meter system with wide range of measurement of reactor water level or investigate the means to understand the condition of the nuclear reactor from containment vessel meter, even if the reactor meter became non functional.]</p> <p>Also, there was no measurement requirement till now, for the things such that hydrogen concentration of the nuclear reactor building and hence, support can not be given to those items which were other than the requirements for measurements. Considering this, the following action is proposed.</p> <p>(4) [Establish a measurement system for the parameters such as concentration of hydrogen inside the nuclear reactor building.]</p> <p>Furthermore, the means for confirming authenticity of measurement system for important parameters such as nuclear reactor water level etc, under the circumstances of occurrence of severe accident and hence the following action is proposed</p> <p>(5)[Considering the occurrence of severe accident, development of measurement system to reinforce diverse environmental qualifications, measurement methods etc.]</p> <p>■Items mentioned in this report 4.10.3 Measurement at the time of accident</p> <p>■Examples of counter-measures Preparations to deal with emergency(8)~(12)</p>
	<p>(15)Focused management of equipments for dealing with emergency and completion of one part of the forces.</p>	<p>In case of accident this time, around the J village, all the concerned persons corresponding to the emergency or accident, concentrated the materials and equipments and are providing earnest support from behind. Initially, though people were there in the surrounding area, the mobilization of the part of rescue team forces, supporting the activities of accident management and emergency support materials and equipments, could not be carried out fast as earthquake or tsunami disaster had occurred.</p> <p>For this, the completion of the rescue team supporting the management of emergency support materials and equipments and their practical use, is promoted so that the support for emergency conditions can be smoothly carried out even in case of severe conditions.</p>	<ul style="list-style-type: none"> <li>• In order to carry out restoration rapidly at the time of accident, sufficient devices to process rubble etc should be deployed. Ensure sufficient protection clothes, protection mask under high radiation dose, the procedures for doing transactions between the enterprises during a period of dealing with accident, should be defined.</li> <li>• Complete the management system of collection of all the emergency support equipments including robot or unmanned helicopter. Reinforce the completion of one part of the rescue team forces having high level of skills of supporting emergency conditions by practically using these equipments.</li> </ul>	<p>About the diversification of means of transport by assuming conditions such as blocking of access route or simultaneous occurrence of accident in multiple units, and about the preparation of materials and equipments, the lessons from the accident this time, are、</p> <p>(1)Bringing of important heavy guns and materials and equipments and their deployment</p> <p>(2)Establish the means of air transport as well as transport through sea, instead of land transport, completion of setup</p> <p>(3)Finalizing of means for setup of finance between enterprises and reconfirmation.</p> <p>(4)Establish equipments or devices (robot, unmanned helicopter etc) for remote operation under high radiation conditions, of the reactor in case of emergency. Cooperation for the investigation committee concerning the development and practical use of such equipments, as well as, for actual bringing in of the equipments, perform setup of cooperation between the enterprises and related equipments.</p>

Group name	Items	Contents	Additional requirements in attachment data	Comparison with the measures of this report
				<p>Investigation is done to promote completion of one part of the rescue forces, while using the existing resources from the country or self governing body. Also, it is also considered that there can be conditions when transportation by normal means is not possible. The cooperation is planned beforehand such that requests for cooperation of self defense force etc is possible.</p> <p>■Items mentioned in this report 4.10.9 Provision for emergency counter-measures (heavy gun, rescue), cooperation set-up in case of emergency</p> <p>■Examples of counter-measures Preparations to deal with emergency (20), (21),(41)~(43)</p>
Support for nuclear hazard	(16)Support for complex circumstances of nuclear reactor disaster and large scale natural calamity	<p>This time, along with a large scale natural calamity, there was a nuclear reactor accident leading to extreme difficulties with respect to contact, communication, assembling of people, provision of goods etc. Also, due to prolonged period of reactor accident the measures for evacuation of citizens have been forced to prolong though it was initially assumed for a short duration.</p> <p>For this, support for the conditions when large scale natural calamity as well as nuclear reactor accident simultaneously occurred, the environment should be established which will ensure appropriate means of communication and method of supply of materials. Also, it should be assumed that the nuclear reactor accident can occur for a long time and reinforce the support for mobilization of important persons from every field related to support for accident or disaster.</p>		<p>Presently, due to basic disaster prevention plan, support will be done as a country, self governing bodies, but for that it is being investigated how enterprises will support. Corresponding to the complex conditions, it is necessary to review this basic disaster prevention plan. Afterwards, it is important to do the review as per the investigation done by the country along with the support from the enterprises.</p> <p>However, this report proposes to carry out the reinforcement of arrangement of communication equipments and materials and equipments. Hereafter, we aim to support, investigation of added counter-measures and means of communication with the country, in case of wider investigations.</p> <p>Battery supply which is independent of the nuclear reactor facility and does not have any impact of earthquake, tsunami etc, is allowed.</p> <ul style="list-style-type: none"> <li>• The facility should be done such that the communication setup for server and converter etc which are used in case of emergency, cable communication circuit and wireless relay base, should not cut off due to natural calamities such as earthquake, tsunami etc.</li> <li>• Deploying various communication equipments such as exclusive circuit, satellite phone and, wireless devices etc, and clarify the method of use of these devices.</li> </ul> <p>Assuming the conditions such that, due to natural calamity (earthquake, tsunami), when the access route inside the power plant from outside is blocked, the consolidation of the device to remove rubble is done. The diversification of methods of transportation of people and materials and equipments is important, hence considering the cooperation with the related facilities, basically, the following support is thought of:</p> <ul style="list-style-type: none"> <li>• Identifying and deploying important heavy equipments other than foil holder which is deployed for severe accident counter measures.</li> <li>• Completion of establishment and setup of means of air</li> </ul>

Group name	Items	Contents	Additional requirements in attachment data	Comparison with the measures of this report
				<p>transport , sea transport instead of land transport</p> <ul style="list-style-type: none"> <li>• Based on the support for this accident, identification and deployment of important materials and equipments as well as confirmation of necessary quantity</li> <li>• Completion of procedures for finance transactions between the enterprises reconfirmation and setup in case of emergency.</li> <li>• Establish equipments or devices (robot, unmanned helicopter etc) for remote operation under high radiation conditions, of the reactor in case of emergency. Cooperation for the investigation committee concerning the development and practical use of such equipments, as well as, for actual bringing in of the equipments, perform setup of cooperation between、 the enterprises and related equipments.</li> </ul> <p>■Items mentioned in this report 4.10.7 communication 4.10.9 Preparation of emergency counter-measures (heavy equipment, rescue), cooperation setup for emergency</p> <p>■Examples of counter-measures Preparation with respect to emergency ⑬, ⑳~㉓, ㉔, ㉕, ㉖~㉙</p>
	(17)Reinforcing environment monitoring	Currently, emergency environment monitoring is the duty of local government but, as the environment monitoring equipment damaged by earthquake and tsunami, forced to perform evacuation by base facility for emergency response and counter measures, hence adequate environment monitoring could not be done, to compensate this by taking cooperation of Ministry of education etc agencies monitoring activity was performed.		<p>As the basic plan for Emergency Preparedness, in case of nuclear power disaster monitoring, site boundary and its internal is by operator and outside the site boundary is by local government is decided primarily.</p> <p>On this times nuclear power disaster, site boundary and within premises of power plant monitoring done by operator, similarly local government was doing environment monitoring outside the site boundary, here towards cooperation support as counter measure was assigned to operator</p> <p>Industry supported environment monitoring done by local government, re completion of support structure for Industry along with operators was needed, contents of that completion was thought as bellow</p> <ul style="list-style-type: none"> <li>• Monitoring equipment necessary to accommodate in emergency, reconfirmation of instrument and deploying necessary numbers.</li> <li>• Review of necessary person for support at emergency ,completion of rules related with that dispatch</li> </ul> <p>Important utility need to be reinforced on constant set monitoring host which is based on this time natural disaster – earthquake, tsunami, the contents of reinforce are thought as bellow</p> <ul style="list-style-type: none"> <li>• Reinforce of electric and communication line.</li> <li>• Tolerance reinforce against earthquake, tsunami</li> </ul> <p>Alternative monitoring procedure for Constant set monitoring host etc need to be defined. The contents of the same are</p>

Group name	Items	Contents	Additional requirements in attachment data	Comparison with the measures of this report
				<p>considered as following</p> <ul style="list-style-type: none"> <li>• Review of measurement alternate procedure for Constant set monitoring host instrument</li> <li>• Deploy important equipments and its determine its numbers</li> </ul> <p>■Items mentioned in this report 4.10.8 Environment monitoring</p> <p>■Preparation against Counter – measures side emergency 34-39</p>
	(18) Definition of roles of local and central administrative agencies	<p>During the initial period of the accident, ensuring means of communication was difficult. From this it is seen that, starting from local and central agencies, the communication, cooperation between the related administrative agencies was not sufficient, also the sharing of roles as well as responsibility relationship was not always clear. Basically, regarding the relationship between nuclear reactor disaster counter-measures headquarters and local nuclear emergency response headquarters, relationship between government and Tepco, relationship between Tepco and the actual nuclear power station site, sharing of roles among the internal departments of the government etc, the structure of rights and responsibilities had some uncertain things. Particularly, the mutual understanding between the government and Tepco was not sufficient.</p> <p>Hence, for this, we recommend, starting with nuclear reactor disaster counter-measures headquarters, doing review and defining responsibility relationship and sharing of roles among the related administrative agencies etc, defining and consolidating set-up of roles and responsibilities related to information communication.</p>	<p>[Refer 2011.9.11 Government Report]</p> <p>Regarding the television conference used at the time of nuclear reactor disaster, the plan is to promote consolidation of the government administrative agencies and all the electric supply enterprises so that emergency instructions as well as information collection can be carried out clearly and rapidly, by connecting with the nuclear power station.</p>	<p>As for the items necessary to be investigated, considering the organization / command, order within the enterprises, instructions were given for the following counter measures.</p> <p>Among the support operations in case of emergency, one is to define the time for doing judgment regarding the things which exert bad impact for the convergence of the accident. Preparations should be made such that analysis is done fast and operations can be carried out rapidly.</p> <p>About the basic conditions at the time of accident or the judgement, they can be clear from the analysis of Fukushima daiichi nuclear power plant accident and interview of the concerned people taken by investigative commission, if new facts are identified, investigation should be done to decide whether the counter-measures and lessons should be added or not.</p> <p>Furthermore, regarding nuclear reactor disaster prevention counter-measures, country, local self governing body, related administrative agencies and enterprises should implement as one body , for relation between the other agencies, enterprises should take measures based on result of analysis of this accident, and analysis of investigative commission.</p> <p>■Items mentioned in this report 4.10.6 organization / command order</p> <p>■Examples of counter-measures Arrangements corresponding to emergency (29)</p>
	(19) Reinforce the communication related to the accident	<p>Regarding sharing of information with the citizens in the surrounding area, in the initial period when accident has occurred, difficulties came due to damage of means of communication owing to the occurrence of large scale earthquake disaster. After this, even information communication with the citizens of the surrounding area or with the self governing bodies could not be achieved at proper timing. Moreover, there was no sufficient, easy-to-understand explanation regarding thinking of International Commission on Radiological Protection(ICRP) related to radiation protection, or health impact of radiation for the citizens in the surrounding area. Also, regarding official announcement of information to the nationals, the precise facts have always been announced to the public till now but the review of risks etc have never been described in details official announcement of information to the nationals and hence, there was anxiety regarding future happenings.</p> <p>Hence, we strengthen sharing of accurate information with the citizens of the surrounding area, giving proper explanation regarding impact of radiation.</p> <p>Regarding the information announcement when accident was progressing,</p>		<p>AT the time of this accident, it was under the jurisdiction to give instructions regarding evacuation of citizens in the surrounding area, hence this topic is not raised in this report which is for the industry.</p> <p>However, press was carried out on enterprise side also, and lessons should be extracted from the press conditions this time. The examples of counter-measures related to official announcement of environment monitoring data etc, are specified.</p> <p>It is important to define the means of communication or the contents of the important information to be communicated to general people, related administrative agencies, persons related to the actual site actual site. Following things are thought of regarding this.</p>

Group name	Items	Contents	Additional requirements in attachment data	Comparison with the measures of this report
		attention should be given to the point that information should include the description of future risks etc.		<ul style="list-style-type: none"> <li>• Contents of information to be communicated, the method of deciding this, sorting out necessary persons</li> <li>• Means for transmission (press, HP etc) and study of official announcement timing</li> </ul> <p>■Items mentioned in this report 4.10.8 Environment monitoring</p> <p>■Examples of counter-measures Arrangements related to emergency (40)</p>
	(20)Strengthening of dealing with aid from each nation and information sharing with the public	<p>After the occurrence of this accident, the proposals regarding aid of materials and equipments from each nation could not be dealt sufficiently as there was no system in place within the government which will associate this with the news in the country. Also the communication was not done beforehand with the neighboring countries and with the community about the release of water contaminated with low radiation levels. Thus there was no sufficient information sharing with the international community.</p> <p>Hence, a list of stock of materials and equipments should be prepared beforehand for international cooperation. In case of accident, the contact points of each nation should be clearly kept in advance. The things such as strengthen the setup of information sharing by improving the international reporting system, enable evidence based reports, provide information more rapidly and accurately should be done and a proper structure should be formed for effectively dealing with international world.</p>		<p>There is no topic raised regarding the government support offered by each country and information sharing in this industrial report.</p> <p>However, the investigation is being done regarding the related industries such as national nuclear power industrial organizations such as WANO and INPO and the nuclear reactor related administrative agencies.</p>
	(21)Prediction of accurate understanding of release of radioactive material	<p>System for Prediction of Environmental Emergency Dose Information network system (SPEEDI) could not obtain information about the source of release of radiation, hence prediction of impact of radiation based on the original source of information, could not be done. Due to such constraints, And hence according to SPEEDI, with certain assumptions, and hence guessing the spreading tendency of the radioactive material, the action to execute evacuation was must. Also, regarding the calculation results of SPEEDI, things from the initial stage till the necessary information was officially announce.</p> <p>Hence, strengthen the measuring equipment which will clearly obtain the information about the source of release at the time of accident. Also, while SPEEDI etc provide effective action plan in various situation , the result of actions should also be officially announce from initial stage.</p>		<p>Regarding the activities of SPEEDI, it is under the jurisdiction of government and hence no topic is raised in this industrial report.</p> <p>Counter-measures of strengthening the environment monitoring utilities of the nuclear power plant which are implemented by the enterprises are specified which are not about the source of release at the time of accident, but used to understand the impact of radioactive material</p> <p>Strengthening important utilities for posting constant monitoring, based on this natural disaster(earthquake, tsunami), is important.</p> <p>The contents to be strengthened are thought as below:</p> <ul style="list-style-type: none"> <li>• Strengthening of electric supply and transmission line.</li> <li>• Strengthening the tolerance with respect to earthquake, tsunami</li> </ul> <p>Also, to strengthen the means of communication with the outside, following counter-measures are specified.</p> <p>counter-measures.</p> <p>■Items mentioned in this report 4.10.8 environment monitoring 4.10.7 communication</p> <p>■Examples of counter-measures Arrangements related to emergency (37),(38),(31)</p>
	(22)Define the wide area	In case of this accident, from the start of accident occurrence, evacuation zone and		About the way of having a complete system for disaster

Group name	Items	Contents	Additional requirements in attachment data	Comparison with the measures of this report
	evacuation or radiation protection standards at the time of nuclear reactor disaster	<p>the zone where people should be inside their houses, was set , and with the cooperation from all the related people such as police as well as local self governing bodies etc, the evacuation operation initially for the citizens from the surrounding areas, was carried out rapidly. On the other hand, due to the prolonged duration of the accident, the evacuation as well staying inside the residence also got prolonged. After that, as per plan, the evacuation zone and emergency evacuation preparation zone were set and according to that the activities could be carried out very fast as per the guidance of ICRP and IAEA. Furthermore, the scope of the protection area set at the time of this accident, was considered as the area which should be improved as per the protection counter-measures and was increased to about 8~10km.</p> <p>For this, based on the experience of this accident, a structure should be setup to define the scope of wide area of evacuation at the time of accident and guide for radiation protection standards.</p>		<p>prevention, it is under the jurisdiction of the government and hence no topic is raised in this industrial report.</p> <p>However, accompanying the review of plan of disaster prevention, the review of support program at the Tepco side, is to be considered as next investigation topic. Also, the review which needs adjustment with the government as well as self governing bodies, we process by cooperating as enterprises and will be investigated later by checking the related points.</p>
Ensure basic safety	(23) Reinforce safety regulation administration system	<p>Safety regulations as a regulatory agency the primary by Nuclear and Industrial Safety Agency, METI, monitor regulatory administrative agencies the primary by the Nuclear Safety Commission, Cabinet Office, and the implementation of environmental monitoring by provincial and local governments involved in an emergency, ensure nuclear safety divided by the relevant administrative organizations, and their whereabouts were unclear have the primary responsibility to ensure that adequate safety work is carried out to the public on disaster prevention. In addition, the current system, when a large nuclear accident such as this, in order to respond swiftly to mobilize the power had not forced the issue.</p> <p>For this, Nuclear and Industrial Safety Agency is made independent of Ministry of economy, and we should start the investigation for implementing environment monitoring and nuclear safety administration regulations including Nuclear Safety Commission and all the ministries.</p>		<p>Regulatory framework with respect to safety it is under the jurisdiction of the government and hence no topic is raised in this industrial report.</p> <p>However, if there is a chance, we would like to participate in a discussion about the method for the desirable regulation, based on the lessons from this accident.</p> <p>About the way of having an organization from Tepco side, for support for the accident, the following counter-measures are specified.</p> <p>Among the support operations in case of emergency, one is to define the time for doing judgment regarding the things which exert bad impact for the convergence of the accident. Preparations should be made such that analysis is done fast and operations can be carried out rapidly.</p> <p>■Items mentioned in this report 4.10.6 organization/command,order</p> <p>■Examples of counter-measures Preparation related to emergency 29</p>
	(24) Maintaining and reinforcing the legal system, standards and guidelines	<p>The current accident raised many issues regarding the legal system and the related standards and guidelines for nuclear reactor safety and nuclear reactor disaster prevention. Moreover, based on the experiences of the current accident, the IAEA was expected to reflect these experiences in the standards and guidelines.</p> <p>Therefore, the review and maintenance of the legal system concerning the nuclear reactor safety and nuclear reactor disaster prevention and the related standards and guidelines is under progress. In this case, the countermeasures for high ageing of the existing facilities will have to be re-examined not only from the viewpoint of structural authenticity, but also from the viewpoint of the latest findings that include the advancements in system concepts. Furthermore, the orientation of regulation system for technical demands based on latests laws and new findings related to existing authorized facilities has become clear. Also, maximum contributions have to be made by providing related data so that the IAEA can reinforce the standards and guidelines.</p>		<p>Discussion on the reviewed guidelines is a basically regulator's task and is not involved in the task of reporting to the industry. However, he participats in planning of the guidelines review such as positive recommendation of the items which are necessarily reflected in industrial field, discussion in advance, and independently backfeed for the measures which are necessary. Furthermore, the establishment of industry guidelines are expected in the future, to ensure a constant level of voluntary support for the private sector.</p>
	(25) Ensuring well-qualified personnel	<p>In case of an accident along the lines that happened this time, along with experts who can respond to severe accidents, it is also necessary to have experts in the</p>	<ul style="list-style-type: none"> <li>Aim for reinforcing the cooperation within the country as well as with educational</li> </ul>	<p>Until now, each company was engaged in ensuring the talent for its own compnay and the work of the entire industry as a</p>

Group name	Items	Contents	Additional requirements in attachment data	Comparison with the measures of this report
	for nuclear reactor safety and nuclear reactor disaster prevention	<p>fields of nuclear reactor safety, nuclear reactor disaster prevention, crisis-management, and radiation medical treatment, etc. and to handle such events using the latest and best knowledge. Moreover, it is also necessary to not only focus on the current accident, but it is extremely important to develop and promote personnel who are competent and well-qualified in nuclear reactor safety and nuclear reactor disaster prevention in order to ensure long and mid-term nuclear reactor safety work.</p> <p>Therefore, in addition to reinforcing the development of qualified personnel in educational establishments in the fields of nuclear reactor safety, nuclear reactor disaster prevention, crisis management, radiation medical treatment, etc., the talent development activities of nuclear reactor enterprises and regulatory bodies also need to be reinforced.</p>	<p>establishments in order to build up a network of nuclear reactor experts. Reinforce the development of qualified personnel in regulatory bodies and specialized agencies, arrange for active employment of experts including public-private exchange, etc., and regularize the methods of experts in on-site and off-site response.</p>	<p>whole was limited to some activities related to operating in-charge systems that were implemented by the Nuclear Power Technical Society. On the basis of the response conditions in the current accident and from the viewpoint of improving the nuclear power station safety and nuclear reactor disaster prevention, it is necessary to study the important measures for developing qualified personnel for the entire industry and to build a systematic and broad-range talent development system.</p>
	(26) Ensuring self reliance and diversity of safety system	<p>For ensuring the authenticity of safety system, multiplicity was been pursued so far, but there was lack of response to avoid common cause failure, and sufficient self reliance and diversity could not be ensured.</p> <p>Therefore, for accurate handling of the common cause failure and further improvement of authenticity, ensuring self reliance and diversity of safety system is reinforced.</p>	<p>[Refer 2011.9.11 Government Report]</p> <p>For ensuring self reliance and diversity in the types and installation sites of emergency generators and sea water cooling systems, the plan is to reinforce ensuring self reliance and diversity of safety system in addition to the accurate handling of the common cause failure and further improvement of authenticity.</p>	<p>Based on the lessons learned from this accident, counter-measures are examined from the point of multilayered protection, and concrete counter-measures are presented by taking into account self reliance and diversity.</p> <p>Loss of power and loss of heat sink are considered to be the common factors for failure. Although examples of concrete counter-measures against such factors are given, they are the counter-measures that have taken multiplicity and diversity into consideration.</p> <p>To be more specific, the counter-measures are described in '4.12 Summary of Counter-measures' as follows.</p> <p>— Injection / Cooling</p> <ul style="list-style-type: none"> <li>• Flood prevention measures such as bulkhead etc around the sea water pump</li> <li>• Deployment of sea water pump motor spare parts</li> <li>• Flood prevention counter-measures such as core spray system etc of the establishment area related to the safety system</li> <li>• Deployment of movable sea water pump</li> <li>• Preparation of backup power for SRV drive and extra air container</li> <li>• Deployment of backup power for vent operation and driving source</li> <li>• Improvement in the authenticity of existing injection system by deployment of backup power supply car or mass power supply</li> <li>• Flood prevention counter-measures of severe accident counter-measures system</li> <li>• Improvement in the authenticity with the flood counter-measures of severe accident counter-measures system</li> <li>• Portable power pump and hose etc that are independent of existing systems</li> <li>• Ensuring water supply</li> <li>• Heat escape in air through containment vessel vent</li> </ul> <p>— Power supply</p> <ul style="list-style-type: none"> <li>• Install sea wall and breakwater in important safety</li> </ul>

Group name	Items	Contents	Additional requirements in attachment data	Comparison with the measures of this report
				<p>equipments.</p> <ul style="list-style-type: none"> <li>• Flood prevention counter-measures of the important safety equipments in the establishment area</li> <li>• Flood prevention counter-measures such as improvement in the sealing of the opening such as air supply opening and penetration corresponding to the flood height</li> <li>• Water-tightness of the placement location of receiving transformer and switchyard or flood counter-measures of the equipments</li> <li>• Water-tightness of the installation area of the direct current power supply system or flood counter-measures of the equipments</li> <li>• Deployment of backup power supply car or mass power supply, Improvement in the emergency procedures</li> <li>• Improvement in the direct power supply charging route with the backup power</li> </ul> <p>■Items mentioned in this report 4.12 Summary of counter-measures ■Examples of counter-measures Provisions against earthquake / tsunami (1)(2)(5)(7)⑨ Corresponding to the loss of heat sink (1)~(3),⑥,⑧,⑩~⑫ Power supply preparations (1)~(4)</p>
	(27) Effective utilization of the Probabilistic Safety Assessment Methodology (PAS) in the risk management	<p>It was found after systematic examination of the efforts taken to reduce the risks of the nuclear reactor power generation facility that PSA has not been effectively used. In addition, quantitative evaluation of the unusual events such as massive tsunami are very difficult also by using PSA, but with more uncertainty, the efforts that increases the authenticity has not been taken sufficiently by clearly specifying the uncertainty of such risks.</p> <p>Hereafter, apply the PSA again actively and promptly based on the opinion related to the uncertainty and develop the safety improvement measures including effective accident management counter-measures based on that.</p>		<p>Till now the deterministic plan and operations have been conducted, and it has been concluded that the accident will not occur by confirming that the accident will not occur with sufficient conservative conditions. As for this review, it is necessary to evaluate by the PSA though the probability is very low and it is also necessary to improve safety by checking for any event that cliff edge. One of it is the stress tests conducted under the guidelines of the country, and as a result, upcoming new challenges are also taken into consideration. Regarding the efforts to PSA, it is necessary to work on the agenda for the future.</p>
Bring about a culture of safety	(28) Bringing about a culture of safety	<p>All those involved in nuclear power generation should inculcate a safety culture. According to (IAEA), 'Nuclear Safety Culture' means, 'The organization and individual should be prepared with the attitude of an integrated recognition and temperament to give priority according to the importance of nuclear safety issues'. According to our terms, it is a starting point, duty and responsibility of those involved in nuclear power generation. There is no constant improvement in safety, if safety culture is not adopted.</p> <p>However, when compared with this time accident, nuclear operator of our country are those who bear the primary responsibility to ensure the safety along with the organizations and individuals, everybody have looked for the new opinions, which confirms that whether it means vulnerability of own plant, and when it was found that it is affecting the hope of reducing the risk related to public safety of our plant, the sincere efforts are taken to improve the safety measures.</p> <p>Moreover, as personnel who assume the responsibility for ensuring nuclear safety</p>	<ul style="list-style-type: none"> <li>• The country and enterprises need to work on establishing safety objectives of the organizations, promotion, evaluation, improvement of activities for building a safety culture in individuals and organizations, reinforcing the cooperation with educational establishments and working towards developing qualified personnel for regulatory bodies.</li> </ul> <p>[Government Report dated 2011.9.11] Both organizations and individuals involved in nuclear reactor enterprises and safety regulations, are sincerely working on</p>	<p>Following the JCO accident and concealment of troubles by Tokyo Electric Power Company, the nuclear power industry is working honestly towards reinforcing the activities for developing a safety culture. The industry needs to reflect sincerely on the reasons in to why the accident at Fukushima Daiichi Nuclear Power Plant could not be prevented and to review the methods related to safety culture. The industry should work on the future problems in having an ideal safety culture.</p>

Group name	Items	Contents	Additional requirements in attachment data	Comparison with the measures of this report
		<p>for both organizations as well as individuals, the people involved in setting the nuclear power regulations for the country must show sensitivity and agility towards latest findings and opinions, without downplaying even the smallest of doubts related to ensuring safety.</p> <p>Therefore, it is necessary to return the basic focus back on the absolute necessity for pursuing defense in depth for ensuring nuclear reactor safety in the future. The personnel involved in nuclear reactor safety must never neglect learning and gaining expert knowledge related to safety and must work towards building a complete safety culture by always working to find out any weak points in the nuclear reactor safety and to find room for improving the safety.</p>	<p>restructuring the professional attitude towards understanding and gaining new knowledge. Steadfast acquisition of a nuclear reactor safety culture by all organizations and individuals is the starting point for personnel involved in nuclear reactor safety and is an obligation and responsibility. Constant improvement in nuclear reactor safety in places where there is no safety culture is the starting point for ensuring future safety of our country and it needs to be confirmed and implemented through renewed and various formats.</p>	

### Appendix-3.2 Comparison of Recommendation of 12 items of NRC Japan Task Force with the countermeasures of this report

Item	Recommendation	Detailed requirements for electric power	Comparison with the countermeasures of this report
Clarification of regulatory framework	(1) A logical, systematic and consistent regulatory framework should be established to coordinate the defense in depth and risk consideration in a right way for adequate protection.	-	This is related to the concept of regulations and it is not raised as an issue in this report for industry.
Guarantee of protection	(2) NRC should re-evaluate the protection of each active reactor's SSC for earthquake and flood of design standards, and ask business operator to raise the standards if needed.	<p>○ According to the existing requirements and guidelines of RC, earthquake and flood hazards on the premises should be re-evaluated and whenever required, the important security design standards and SSC which must be protected from updated hazards should be updated.</p> <p>○ A walk down preventive measure for earthquake and flood should be implemented, along with the specification and improvement in the plant specific vulnerability, the appropriateness of monitoring and preservation of the protection function such as temporary waterproof barrier and sheet should be verified until the long-term activity to update the design standards for outside events is completed.</p>	<p>For the evaluation of earthquake and Tsunami, the following evaluation conditions are added based on the knowledge acquired from this data.</p> <ul style="list-style-type: none"> <li>· Standard earthquake motion Ss design is considered as almost satisfactory as per the present way of thinking, but working of multiple earthquake centers is considered for further safety assurance.</li> <li>· At the time of evaluation of Tsunami height which arrives along with the earthquake, hereafter the working of multiple earthquake centers is considered as a wave source at plate boundary and the necessity of setting the slip amount of earthquake source fault to a larger value is also verified at the same time.</li> </ul> <p>A possible Tsunami height is evaluated, and protection is provided for the intrusion of Tsunami on the premises. Further, the following several measures are taken and security for the functions of safety equipment is provided.</p> <p>Measures are taken for the intrusion on the premises due to invasion of Tsunami. The concrete example is as follows.</p> <ul style="list-style-type: none"> <li>· Attention is ensured for the arrangement of power-supply system important to safety, and provided with the intrusion due to Tsunami, the storm surge barrier (flood barrier) or breakwater is setup or the protection barrier is setup on important equipment from the viewpoint of multi-tiered protection.</li> <li>· Protection against Tsunami such as tank responsible for problem like a sea wrack at emergency response (protection barrier etc.). Deployment of heavy machinery to remove a sea wrack.</li> </ul> <p>Further, measures are taken for the protection against intrusion in the building. The concrete example is as follows.</p> <ul style="list-style-type: none"> <li>· For a Tsunami which exceeds the assumption, intrusion prevention measure such as improvement in the sealing of opening section and penetration section of the outside door or air supply opening of a building as per Tsunami height is implemented.</li> <li>· For a Tsunami which exceeds the assumption, measures are taken such as improvement in water-tightness of the door necessary to prevent the intrusion in equipments important to safety, and the impact of instruction is determined.</li> <li>· For the early restoration, a portable drainage pump is arranged to pump out the sea water entered in the building</li> <li>· About the impact of wave power of Tsunami, places where there is a direct impact of Tsunami at the outside door facing the sea are considered.</li> </ul> <p>Also, measures for flooding from tsunami are taken for the sea water pump.</p> <ul style="list-style-type: none"> <li>■ Describing section in this report <ul style="list-style-type: none"> <li>4.6 Preparation for earthquake or Tsunami</li> </ul> </li> <li>■ Example of countermeasure</li> </ul>

Item	Recommendation	Detailed requirements for electric power	Comparison with the countermeasures of this report
			Preparation for earthquake Tsunami ① to ⑤, ⑦, ⑩, ⑫
Strengthening mitigative capacity	(3) As a part of long-term re-examination, a possibility of capacity building to prevent or mitigate the earthquake fire and overflow stream must be evaluated.  (4) For the design standards and non-design standards outside events, SBO mitigative capacity of all the active reactors and new reactors should be strengthened.	<p>-</p> <p>○ Rulemaking to revise 10 CFR 50.63 should be started, and for the business operators of active reactors as well as new reactor, (1) Response time of minimum 8 hours should be verified for the station blackout, (2) The equipments, procedure and training required to implement the response time of 72 hours during “station blackout extension” for the reactor core and cooling of already used fuel pool, or soundness of reactor cooling system and primary containment as required, should be established, and (3) External traffic infrastructure function related to the large scale natural disasters should include the capacity to acquire equipment in the given time for response capacity building under significantly reduced conditions, and persistent cooling capability of the reactor core and already used fuel pool on the premises or the external resource to support the soundness of reactor cooling system and primary containment system as required, should be planned and prepared in advance.</p> <p>○ According to 10 CFR 50.54(h)(2), currently provided equipment should be rationally protected from outside events of design standards and together the other requirements are revised and implemented, hence respond to events of multiple reactors by adding equipment as required.</p>	<p>Fire protection measures are already implemented for the fire. And for the internal overflow stream, investigation is in progress as a part of earthquake response of Kashiwazaki Kariwa. But, combining with the earthquake, hereafter it is necessary to continue working on the investigation of measures for composite events.</p> <p>From a power supply security viewpoint, firstly when the secured external power supply was not good, the equipment was already installed to supply the power by emergency DG. However, this time the equipment did not work due to loss of function. Therefore, firstly it is necessary to improve the reliability of external power supply.</p> <p>① The external power supply is based on NISA instructions document "About ensuring reliability of external power supply for nuclear power station and reprocessing plant", and corresponds to the measures (circuit connection, suspension tower strengthening, switching station intrusion measure) to ensure the reliability of power supply. Next, preparation is done by assuming the loss of function of emergency DG.</p> <p>② As a backup power supply of emergency D/G, diversification of power supply is provided by deploying (including the required fuel) the power supply car or power supply with large capacity, and for the power panel, preparation is done for Tsunami invasion by taking intrusion countermeasures. Further, the power supply car is placed on the elevated location. And for DC power supply, separately countermeasures are taken for the loss.</p> <p>③ Battery secures the charging route from backup power supply and also ready for Tsunami invasion by intrusion countermeasures. A good power supply security is achieved by taking these several countermeasures.</p> <p>Following countermeasures are taken to secure the functions of cooling system.</p> <p>① Security of injection measures to the reactor by portable power pump independent of the existing power supply, security of water source for injection including sea water, and depressurization of a good reactor by SRV is necessary in injection, hence a good injection cooling function to the reactor is secured by securing the backup drive force necessary for SRV operation.</p> <p>② Security of alternate last heat sink corresponds to heat escape to the air by container vent.</p> <p>③ The last heat sink security corresponds to the sea water system restoration by early restoration of sea water pump or arrangement of spare parts.</p> <p>About the time factor, it is not necessary to set up the time. Training is conducted by considering the time from loss of function of equipment of safety system to the core damage, and it is cleared through the confirmation of whether the alternative measure is ready before the core is damaged.</p> <p>Further, basically all the necessary equipments are placed inside the power station.</p> <p>Refer to item (7) for cooling of spent fuel pool.</p>

Item	Recommendation	Detailed requirements for electric power	Comparison with the countermeasures of this report
			<ul style="list-style-type: none"> <li>■ Describing section in this report               <ul style="list-style-type: none"> <li>4.7 Preparation for power supply</li> <li>4.8 Heat sink loss response</li> </ul> </li> <li>■ Recommended example of countermeasure               <ul style="list-style-type: none"> <li>Preparation for power supply ① to ⑥</li>   <li>Heat sink loss response ①, ②, ⑧ to ⑩</li> </ul> </li> </ul>
	(5) Pressure vent design should be demanded to BWR provided with Mark type I and Mark type II container.	○ A reliable pressure vent should be installed in BWR provided with Mark I type and Mark II type container.	<p>Not only for the installation of pressure vent, but also to secure a good vent function, as an example of countermeasure for line configuration</p> <p>① In case of loss of existing drive source, the security of backup drive source (power supply or pump) which is required to operate the container vent valve is increasing.</p> <p>And the vent operating procedure will be considered hereafter, by taking into consideration the possibility of over temperature failure.</p> <p>② Investigation will proceed for “Optimization of operating conditions of vent” and “Preventive measures for the leakage (wrap) to neighbouring unit from vent exhaust line”.</p> <p>③ Further, investigation is carried out as a countermeasure for cooling by container alternate spray after core damage.</p> <ul style="list-style-type: none"> <li>■ Describing section in this report               <ul style="list-style-type: none"> <li>4.8.3 Container vent</li> <li>4.9 Hydrogen measure</li> </ul> </li> <li>■ Example of countermeasure               <ul style="list-style-type: none"> <li>Heat sink loss response ①, ③ to ⑤</li> <li>Hydrogen measure ③</li> </ul> </li> </ul>
	(6) Hereafter with the disclosure of additional information by investigation of an accident occurred in Fukushima Daiichi Nuclear Power Station, a vision should be determined for mitigation and hydrogen control in the container and in the building as a part of long-term re-examination.	—	<p>For the hydrogen which may generate due to the oxidizing reaction between reactor coolant and fuel cladding, based on the past design basis events, the atmosphere in the reactor containment is made below the fuel limit by preventing the hydrogen generation by core cooling such as emergency core cooling system or by creating inert gas environment by nitrogen sealing to reactor containment in the boiling water reactor (BWR) even though the hydrogen is generated suddenly.</p> <p>However, when hydrogen is generated in the same container of BWR and design conditions are exceeded, the hydrogen leakage occurred inside the reactor building. Hence, ① “Countermeasure to release or reduce the hydrogen retained inside the reactor building” and ② “Installation of hydrogen gas detector to properly monitor the retention of hydrogen in the reactor building, along with the investigation of a channel where the hydrogen leaked inside the reactor building” are recommended.</p> <p>Moreover, during container vent in severe accident management response, ③ “Prevention of hydrogen wrap from the ventilation pipe when a branch pipe is placed in the container vent line” and ④ “Prevention of hydrogen wrap to other units sharing the vent stack” are recommended to prevent the wrap of hydrogen inside the reactor building, and tried to prevent the accumulation of hydrogen inside the reactor building.</p> <p>In this way, for the hydrogen which may generate in the reactor core, explosion of reactor building due to accumulation of hydrogen can be prevented by taking the above countermeasures.</p> <p>Further, the hydrogen explosion can be prevented by ensuring the action on hydrogen generation prevention and release countermeasures, and hence it is</p>

Item	Recommendation	Detailed requirements for electric power	Comparison with the countermeasures of this report
			<p>not necessary to install flammable gas control system in the reactor building in BWR.</p> <ul style="list-style-type: none"> <li>■ Describing section in this report 4.9 Hydrogen countermeasure</li> <li>■ Example of countermeasure Hydrogen countermeasure ① to ④</li> </ul>
	(7) Condenser capacity and instrumentation of spent fuel pool should be strengthened.	<p>○ Enough safety system instrumentation which can withstand natural phenomenon of design standards, and can be monitored from the control room of important parameters (water level, temperature and area radiation level) of spent fuel pool should be provided.</p> <p>○ Safety system AC power supply should be provided to the makeup system of spent fuel pool.</p> <p>○ Technical specifications should be revised so that the demand to provide operable one house emergency power supply train for the makeup and instrumentation of spent fuel pool is fulfilled, irrespective of the operation mode of a reactor, when there is irradiated fuel in the spent fuel pool.</p> <p>○ Already installed equipment to spray the water on the spent fuel pool which is confirmed after considering the earthquake should be provided including the connection where the access to water supply is easy on the same plane (by using the portable pump or pump train) as external building.</p>	<p>In the security of a reliable cooling function of a spent fuel pool, it is extremely important that the water level in the pool is maintained even if the cooling function is lost and the spent fuel is not exposed. For that, securing alternative injection measure is important. For example, countermeasures such as injection by fire extinguisher car or pump car and together the security of injection route and water source can be considered.</p> <p>Moreover, it is necessary to intensify the monitoring function of pool water level and pool water temperature to check the validity of alternate injection measure. For example, power supply to the level instrumentation and thermometer from emergency power supply or monitoring enhancement of pool using battery drive ITV can be considered as countermeasures.</p> <p>In this way, soundness of the spent fuel can be secured by maintaining the pool water level by injection to the spent fuel pool, but this can also be raised as an example of countermeasure to get further improvement of reliability or a measure to maintain the cooling function.</p> <p>In Fukushima Daiichi Nuclear Power Station, it is good enough from the viewpoint of fuel damage prevention that to certainly supply the water by temporary equipment, than making a power supply of a permanent makeup water system when all the power supply is lost. (Therefore, it is not necessary to revise the technical specifications.)</p> <ul style="list-style-type: none"> <li>■ Describing section in this report 4.11 Soundness security of spent fuel</li> <li>■ Example of countermeasure Soundness security of spent fuel ① to ③</li> </ul>
	(8) The ability to respond during emergency in the facilities such as plant emergency operation procedure (EOP), severe accident management guidance (SAMG) and EDMG must be strengthened and integrated.	<p>○ Technical guidelines (supplement 1 "Requirements for emergency response ability" for NUREG-0737 in GL 82-33) for plant emergency operation procedure must be revised so as to (1) include the plant emergency operation procedure, severe accident management guidance and EDMG in an integrated format, (2) specify precise command and control strategy related to the implementation and (3) grant the rights and provide training to the staff with suitable qualifications to make a decision during emergency.</p> <p>○ Section 5.0 "Administrative control" of standard technical specifications to refer to technical guidelines for plant emergency operation procedure approved for plant in each reactor operation design must be revised, and the technical specifications of each plant must be revised so as to comply with those changes.</p>	<p>· Countermeasure is taken such as installation of equipment by considering all power supply loss or heat sink loss, and measures are also raised for making the procedure for that.</p> <p>· As a countermeasure related to the organization/command or order, for the things which get badly affected by accident convergence due to delay in the judgment, the timing of judgment is clarified, and external adjustment is carried so that the operation can be done quickly. And a countermeasure to buildup communication facility is also raised. On the emergency station, securing collection means of the plant parameters required for command is also raised as a countermeasure.</p> <p>About the qualification, it is not demanded officially, but seeking to secure a knowledge and technique as a part of training.</p> <ul style="list-style-type: none"> <li>■ Describing section in this report 4.7 Preparation for power supply 4.8 Heat sink loss response 4.10.1 Training 4.10.4 Emergency station 4.10.6 Organization/command or order</li> </ul>

Item	Recommendation	Detailed requirements for electric power	Comparison with the countermeasures of this report
			<p>4.10.7 Communication</p> <p>■ Example of countermeasure Preparation for power supply ①, ④ Heat sink loss response ①, ③, ④, ⑥, ⑧ to ⑩</p> <p>Preparation for emergency time ⑦ to ⑦, 24, 28, 29, 31 to 33</p>
Strengthening emergency response	(9) NRC should request the summary to respond to long-term SBO and multiple unit events in facility emergency countermeasures.	<p>○ The following points should be implemented until rule making activity is completed.</p> <ul style="list-style-type: none"> <li>· Determination of workers to fulfill all the positions required to respond to multiple unit events and its implementation.</li> <li>· Addition of guidelines in the documented emergency plan for the implementation method of multiple unit dose evaluation (including the discharge from spent fuel pool) using the dose evaluation software and approach specialized for the facility given by business operator.</li> <li>· Implementation of periodical training and practice for multiple units and long-term SBO scenario. Exercise related to the identification and acquisition of non-institutional resources within the possible range (simulate).</li> <li>· Assurance about the fact that facilities and equipment for emergency response will properly deal with the scenario of multiple units and long-term SBO.</li> <li>· Power supply measures to communication equipment required for the communication within the plant (wireless communication between the response team and the plant etc.) as well as outside the plant (cellular phone, satellite phone etc.) during long-term SBO.</li> <li>· Maintenance of capacity of emergency response data system throughout the accident occurrence period.</li> </ul> <p>○ To secure the monitoring capability of multiple units, initiative to bring the emergency response data system to the last state needs to be completed before June 2012.</p>	<ul style="list-style-type: none"> <li>· Countermeasure is taken such as installation of equipment by considering all power supply loss or heat sink loss, and measures are also raised for making the procedure for that.</li> <li>· For communication equipment strengthening or emergency response for system, instrument, monitoring, measures cited in the countermeasures. Its validity will be checked through training.</li> <li>· Implementation of training is raised as a countermeasure. Whether the preparation to respond to multiple units is done will be checked through training, and as a result, re-examination such as strengthening of system will be carried out if required.</li> <li>· Provision of disaster control measures and building a cooperative system are taken as measures for resources.</li> </ul> <p>■ Describing section in this report 4.7 Preparation for power supply 4.8 Heat sink loss response 4.10.1 Training 4.10.7 Communication 4.10.8 Environmental monitoring</p> <p>■ Example of countermeasure Preparation for power supply ①, ④ Heat sink loss response ①, ③, ④, ⑥, ⑧ to ⑩</p> <p>Preparation for emergency time ⑦ to ⑦, 30 to 43</p>
	(10) As a part of long-term review, NRC should search for additional themes to emergency response, which are related to multiple unit events and long-term SBO.	<p>○ <i>Based on the insights taken from Fukushima Daiichi Nuclear Power Station accident, analysis should be carried out for emergency responder about the requirements and guidelines related to the current security equipment.</i></p> <p>○ <i>About long-term SBO or multiple unit events or both, to secure the existence of proper level authority and monitoring system in a proper plant, evaluation should be carried out for command and control formulation as well as qualifications of the decision-maker.</i></p> <p>○ <i>Emergency Response Data System (ERDS) is evaluated by using the following methods.</i></p> <ul style="list-style-type: none"> <li>· <i>Alternative methods (such as satellite connection) are determined to send the data of emergency response data system, which is independent of the fixed-line infrastructure which may not be useful during large scale natural disaster.</i></li> <li>· <i>Currently received data set in various locations determines whether the conditions necessary in the updated evaluation are fulfilled.</i></li> <li>· <i>During emergency, whether the emergency response data system should continuously send the data so that the operator need not perform it is determined.</i></li> </ul>	<ul style="list-style-type: none"> <li>· As a countermeasure related to the organization/command or order, for the things which get badly affected by accident convergence due to delay in the judgment, the timing of judgment is clarified, and external adjustment is carried so that the operation can be done quickly. And a countermeasure to buildup communication facility is also raised. On the emergency station, securing collection means of the plant parameters required for command is also raised as a countermeasure.</li> <li>· About the qualification, it is not demanded officially, but seeking to secure a knowledge and technique as a part of training.</li> </ul> <p>■ Describing section in this report 4.10.1 Training 4.10.7 Communication</p> <p>■ Example of countermeasure</p>

Item	Recommendation	Detailed requirements for electric power	Comparison with the countermeasures of this report
	(11) As a part of long-term review, NRC should search for emergency response related to decision-making, radiation monitoring and promotion of citizens.	<p><i>○ Investigation should be carried out by emergency response resources within the plant about whether it is necessary to effectively implement the emergency response such as transportation capacity of local equipment, when there is no support from outside the plant or the support is delayed since the infrastructure outside the plant is destroyed due to the extensive natural disaster or there are other priorities for response resource.</i></p> <p><i>○ Insights obtained from the implementation of emergency response in Fukushima should be evaluated.</i></p> <p><i>○ Validity (including consideration about independence from AC source, availability of real-time internet) of radiation monitoring within the plant and in the range of emergency planning zone in real-time should be investigated.</i></p> <p><i>○ Training about radioactivity, its safety and correct dose method KI should be implemented in a local community around each nuclear power station.</i></p>	<p>Preparation for emergency time 27 to 28, 24, 28, 29, 31 to 33</p> <p>Country and the local government have carried out the monitoring at the time of accident and publicity of its result, and power will cooperate with that system. In response to this accident, investigation for accident response such as monitoring is proceeding in the country, but voluntary measures are taken regarding cooperation for the power.</p> <p>Basically, countermeasures are implemented for the following items.</p> <ul style="list-style-type: none"> <li>- Monitoring equipment required in advance for emergency, reconfirmation of equipment and their deployment as required</li> <li>- Re-examination of the supporting staff necessary during emergency and upgrading the rules related to their dispatch</li> <li>- Strengthening of power supply and transmission line</li> <li>- Buildup resistance for earthquake and Tsunami</li> <li>- Re-examination of the test procedure by alternative measures such as temporary monitoring equipment</li> <li>- Information to send, its compilation method and arrangement of the required staff</li> <li>- Review of means of communication (press, HP etc.) or announcement timing</li> </ul> <ul style="list-style-type: none"> <li>■ Describing section in this report 4.10.8 Environmental monitoring</li> <li>■ Example of countermeasure Preparation for emergency time 34 to 40</li> </ul>
Efficiency improvement of NRC program	(12) NRC should strengthen the regulatory monitoring for a safety record (that is, reactor oversight process) of a business operator, by keeping the focus on requirements to defense in depth which conform to the recommended defense in depth framework.	<i>○ To include the consideration of defense in depth completely, annual self-assessment of reactor oversight process and reorganization of reactor oversight process every 2 years should be implemented.</i>	<p>This is not raised as an issue in this report for industry as it is a regulator's approach.</p> <p>Further, hereafter in the peer review carried out by WANO or JANTI, EP or SAM will also be tackled as review items.</p>

(Note) Text written in Italic is the countermeasure which may relate to both regulations as well as business operator.

## Appendix -4 MARK-I Containment

Various arguments have been raised concerning the MARK-I Containment. We will summarize the industry's opinions on the MARK-I Containment as below. With regard to the details of the arguments, please access General Electric Co. website ([http://www.ge.com/jp/docs/1307504328207\\_NEI\\_Report.pdf](http://www.ge.com/jp/docs/1307504328207_NEI_Report.pdf)) to read the explanations.

Primarily, MARK-I containment has been designed to have sufficient strength by being compliant to various design requirements including the seismic resistance. Further, the recent engineering findings have been integrated in the facilities at each stage. Accordingly, the safety performance of the MARK-I containment is judged as equivalent at least to the other containment models.

The points raised as targets of arguments are the 4 items as below:

1. The containment is vulnerable to earthquakes
2. Because of small containment capacity, the capacity for absorbing the energy discharged from the core in the event of accident is low.
3. The containment is likely to be damaged when dynamic load is applied to the inner wall of its suppression chamber in the event of disasters such as an earthquake.
4. Containment Failure Probability is high when a severe accident is assumed.

Our opinions on these points are indicated below.

### 1. Earthquake-resistant performance of MARK-I Containment

MARK-I Containment has following characteristics:

- A suppression chamber is arranged on the side of RPV.
- Its center of gravity is low, because low containment can be made.
- Its center of gravity is low, because the position to arrange RPV in the containment is low.

In MARK-I Containment, height of the facility can be made low by arranging the suppression chamber on the side of PRV. At the same time, it contacts the ground with wider area.

Accordingly, the MARK-I is considered as an advantageous containment type in terms of aseismic design.

A comparison of MARK-I Containment and MARK-II Containment is indicated in Figure Appendix-4-1.

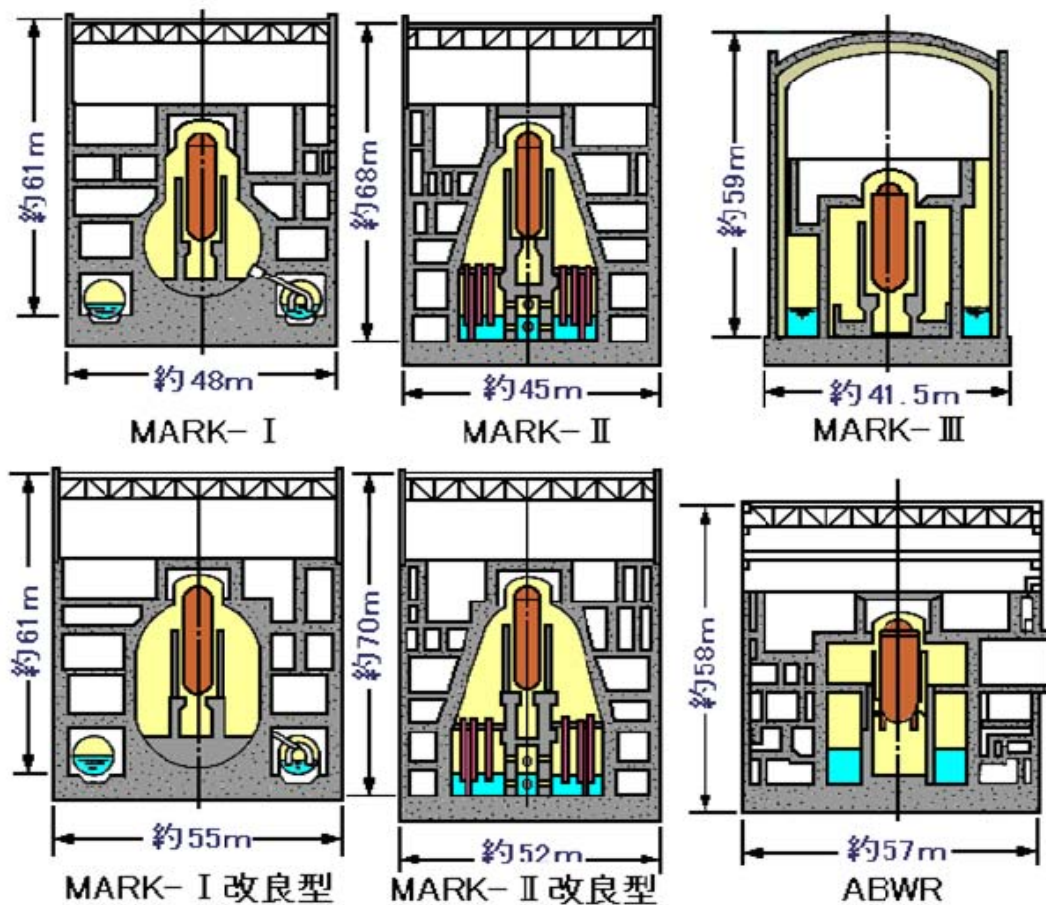

Figure Appendix-4-1

## 2. Capacity of MARK-I Containment

The energy discharged in the event of an accident is proportional to the thermal output of the reactor. Comparing the proportion of reactor containment capacities that absorb the energy, the proportion of MARK-I Containment is higher than those of MARK-II containment or PCCV. While the capacity of the MARK-I Containment is smaller, it shows an equivalent level of energy absorption to the energy absorption in other models in terms of absorption of energies discharged from the core in the event of an accident.

Table Appendix-4-1 indicates the average containment space volume and the average reactor thermal output in MARK-I Containment and the other types of containments.

**Table Appendix-4-1 Containment space volume versus thermal output**

Containment type	Average containment space volume [m <sup>3</sup> ]	Average reactor thermal output [MW]	Containment space volume ÷ thermal output [m <sup>3</sup> /MW]
MARK-I	6558	1681.8	4.10
MARK-I (Revised)	12500	2581.2	4.95
MARK-II	9775	3293	2.96
MARK-II (Revised)	14406	3293	4.37
RCCV	13355	3926	3.40

## 3. Dynamic load to suppression chamber pool

Following two conditions are considered to generate pressure on internal wall of the suppression chamber in the arguments.

- (1) Earthquake
- (2) Steam discharge from SRVs

### (1). Earthquake

As indicated below, dynamic load by an earthquake is not a MARK-I Containment-specific problem.

Following 2 items are the key points in the arguments:

- Sloshing of pool water caused by an earthquake generates a dynamic load on the internal wall of suppression chamber.
- Sloshing of pool water caused by an earthquake results in exposure of steam exhaust pipes from SRVs to the suppression chamber space. If this event occurs concurrently with a loss of coolant accident, steam from RPVs is discharged directly to the suppression chamber space. This may elevate the pressure inside the suppression chamber.

The dynamic load generated by sloshing of pool water under the impact of an earthquake has been confirmed to have no negative impact based on the structural analysis. With regard to the SRV exhaust pipes, the exhaust pipes should not come above the water level, even if the water level of the suppression pool is the lowest and considering the point where amplitude of the pool water sloshing is the maximum. Therefore, it is confirmed that the event raised in the arguments never occurs.

(2). Impact of steam discharge from SRVs

A countermeasure has been implemented against the dynamic load through the SRV steam applied on internal wall of the suppression chamber. Therefore, it does not constitute a problem specific to MARK-I Containment.

When an internal pressure of RPV elevates, SRVs are actuated to discharge RPV steam into the water of suppression chamber pool with the purpose to prevent damage on the RPV.

In this occasion, the possibility of applying a local dynamic load on suppression chamber has been pointed out due to local discharge of the steam.

To address this issue, an improvement was conducted so that the steam exhaust pipe should be located on the cross type nozzle instead of a straight nozzle. In this configuration, the steam is distributed and discharged into the water (quencher type). Based on this modification local pressure can be avoided.

4. Security of containment integrity based on the assumption of a severe accident

Each operator carried out the probabilistic safety assessment (PSA), identify and implement valid countermeasures against the severe accidents. Integrity of the containment in the event of severe accident is secured based on this process.

Following two factors are identified as causes of the containment damage:

- Pressure that exceeds maximum operating pressure of the containment
- Temperature that exceeds maximum operating temperature of the containment

Following four countermeasures have been examined and implemented to maintain integrity of the containment by eliminating the aforementioned damage factors.

1. Containment vent
2. Alternative coolant injection
3. Containment spray
4. Alternative cooling

## **Reference -1 Plant Overview**

Plant overviews for the Units 1, 2 and 3 of Fukushima Daiichi Nuclear Power Station are indicated in Table Reference -1, Figure Reference1-1 and Figure Reference 1-2. Further, the outlines of severe accident countermeasures already implemented in the Units 1, 2 and 3 are indicated in Table Reference-2 and from Figure References 1-3 through Figure Reference 1-8.

**Table Reference 1-1 Plant overview**

Plant	Unit 1	Unit 2	Unit 3
Reactor type	BWR3	BWR4	BWR4
Containment type	Mark-I	Mark-I	Mark-I
Thermal output (MWt)	1380	2381	2381
Power output (MWe)	460	784	784
Fuel assembly #	400	548	548
Control rod #	97	137	137
Safety relief valve	4	8	8
Safety valve	3	3	3
Emergency condenser (Heat exchanger #)	2	—	—
Cooling system at isolation ( Pump #)	—	1	1
Emergency core cooling system ( Pump #)	HPCI:1 CS:4 ADS	HPCI:1 CS:2 LPCI:4 ADS	HPCI:1 CS:2 LPCI:4 ADS
Containment cooling system / Residual heat removal system	—	2	2
Containment cooling sytem ( Pump #)	4	—	—
Shutdown cooling system ( Pump #)	2	—	—
Emergency DG (Unit #)	2	2	2
Containment capacity	DW:3410 m <sup>3</sup> WW:2620 m <sup>3</sup> SP:1750 m <sup>3</sup>	DW:4240 m <sup>3</sup> WW:3160 m <sup>3</sup> SP:2980 m <sup>3</sup>	DW:4240 m <sup>3</sup> WW:3160 m <sup>3</sup> SP:2980 m <sup>3</sup>

**Table Reference 1-2 Countermeasures implemented for severe accident**

Function	Countermeasure for severe accident	Unit 1	Units 2/3
Reactor shutdown function	Recirculation pump trip (RPT)	○	○
	Alternative control rod insertion (ARI)	○	○
Coolant injection to reactor and containment	Alternative coolant injection (Coolant injection to reactor / containment by using condensate water makeup system/ Fire extinguishing pump etc.)	○	○
	Automatic actuation of reactor depressurization (Addition of ADS interlock)	—	○
Function to remove heat from containment	Alternative heat removal (Positive use of DW cooler / Reactor coolant cleanup system)	○	○
	Restoration of failed component of residual heat removal system (Procedure)	○	○
	Pressure resistant reinforced vent	○	○
Function to support safety features	Additional installation of emergency D/Gs (2 dedicated DGs for each plant)	○	○
	Interchange of power source (480V is made available by adjacent plant)	○	○
	Restoration of failed component of emergency D/Gs (Procedure)	○	○

What is the countermeasure against severe accident (=accident management)?

A countermeasure against severe accident (=accident management) means a countermeasure to prevent development of an event that may lead to a severe accident (=a large scale accident that may result in a serious damage of reactor fuels) as well as a countermeasure to mitigate the impacts of a severe accident even if the event should develop into a severe accident.

In May, 1992, the Nuclear Safety Commission made recommendations on the accident management for severe accidents, and in July, the government requested each electric utility to implement an accident management. In these recommendations, electric utilities are requested to make voluntary commitments to reduce accident risks and to enhance safety, although it is admitted that no additional safety regulations are necessary because the safety in the domestic nuclear power stations has been sufficiently guaranteed by currently available safety measures.

Upon receiving these recommendations, electric utilities have implemented their own accident management measures and a report summarizing the contents of these measures was submitted to the government in May 2002. The Nuclear Safety Commission reviewed the report and evaluated that the countermeasures developed by electric utilities were appropriate.

In the accident management, a situation is assumed where abnormality (or abnormalities) occurred and the entire emergency core cooling system (ECCS) failed. In such a situation, some special countermeasures are taken such as pumps normally used for fire extinguishing are used to inject coolant to the core for cooling the fuels. In the accident management, it is necessary to make most of the components originally used for some other functions to address an abnormal situation so as to prevent development of the event and to mitigate its impacts.

Accident management is also a requirement in IAEA standards.

#### IAEA NS-G-2.15 SEVERE ACCIDENT MANAGEMENT PROGRAMMES FOR NUCLEAR POWER PLANTS

1.4. Accident management is the taking of a set of actions during the evolution of a beyond design basis accident:

- (a) To prevent the escalation of the event into a severe accident;
- (b) To mitigate the consequences of a severe accident;
- (c) To achieve a long term safe stable state [4].

The second aspect of accident management (to mitigate the consequences of a severe accident) is also termed severe accident management. Accident management is essential to ensure effective defence in depth at the fourth level

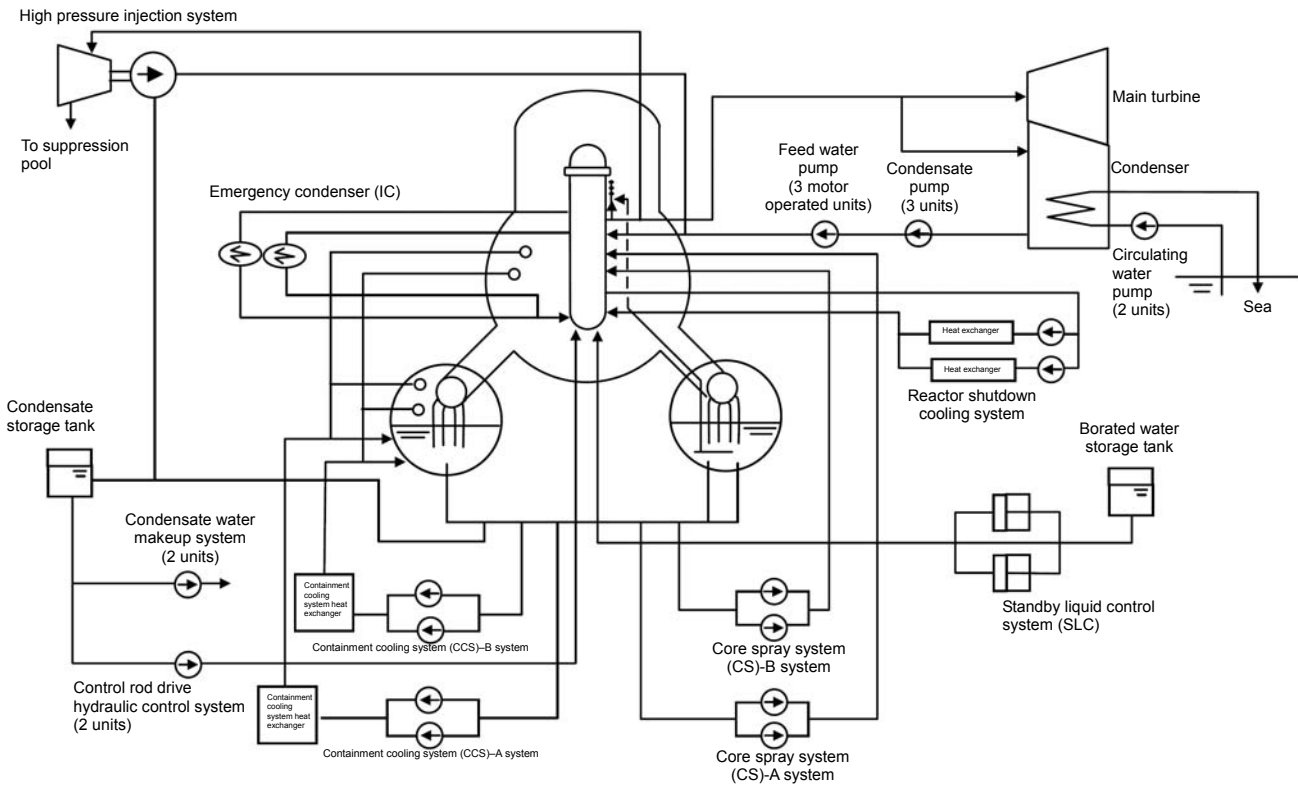

**Figure Reference1-1 Plant overview (Unit 1)**

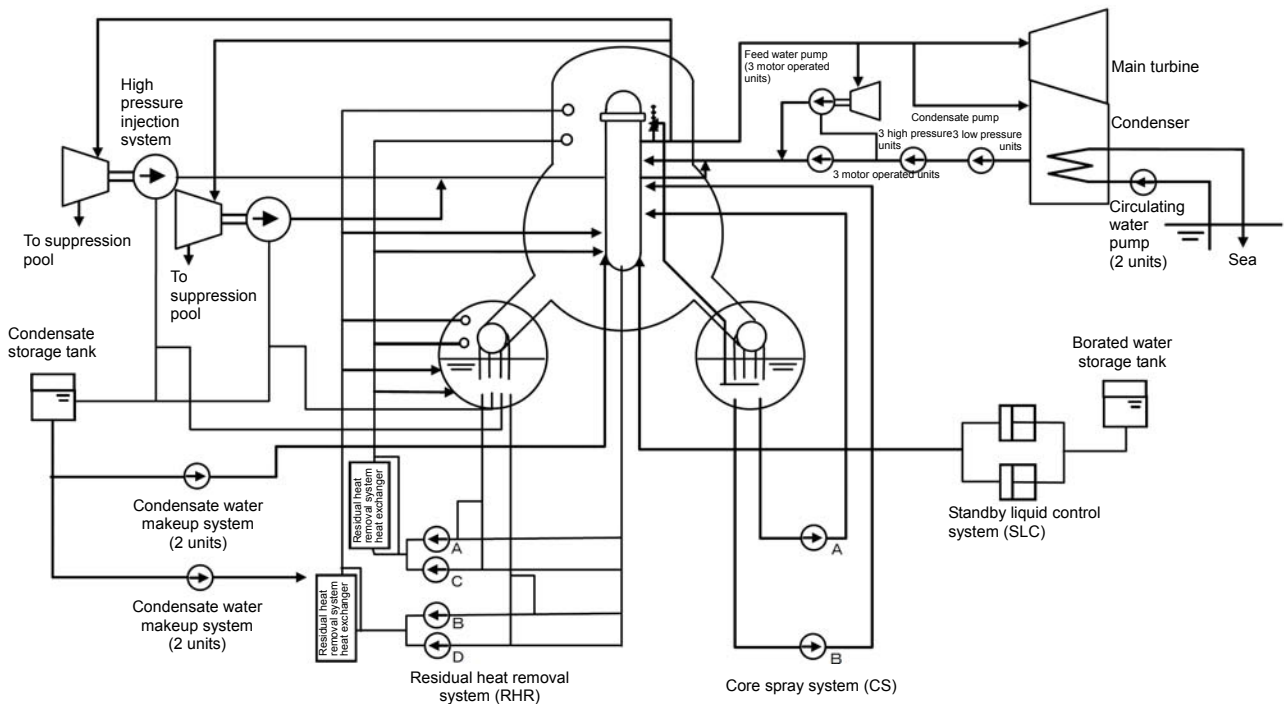

**Figure Reference1-2 Plant overview (Units 2 / 3)**

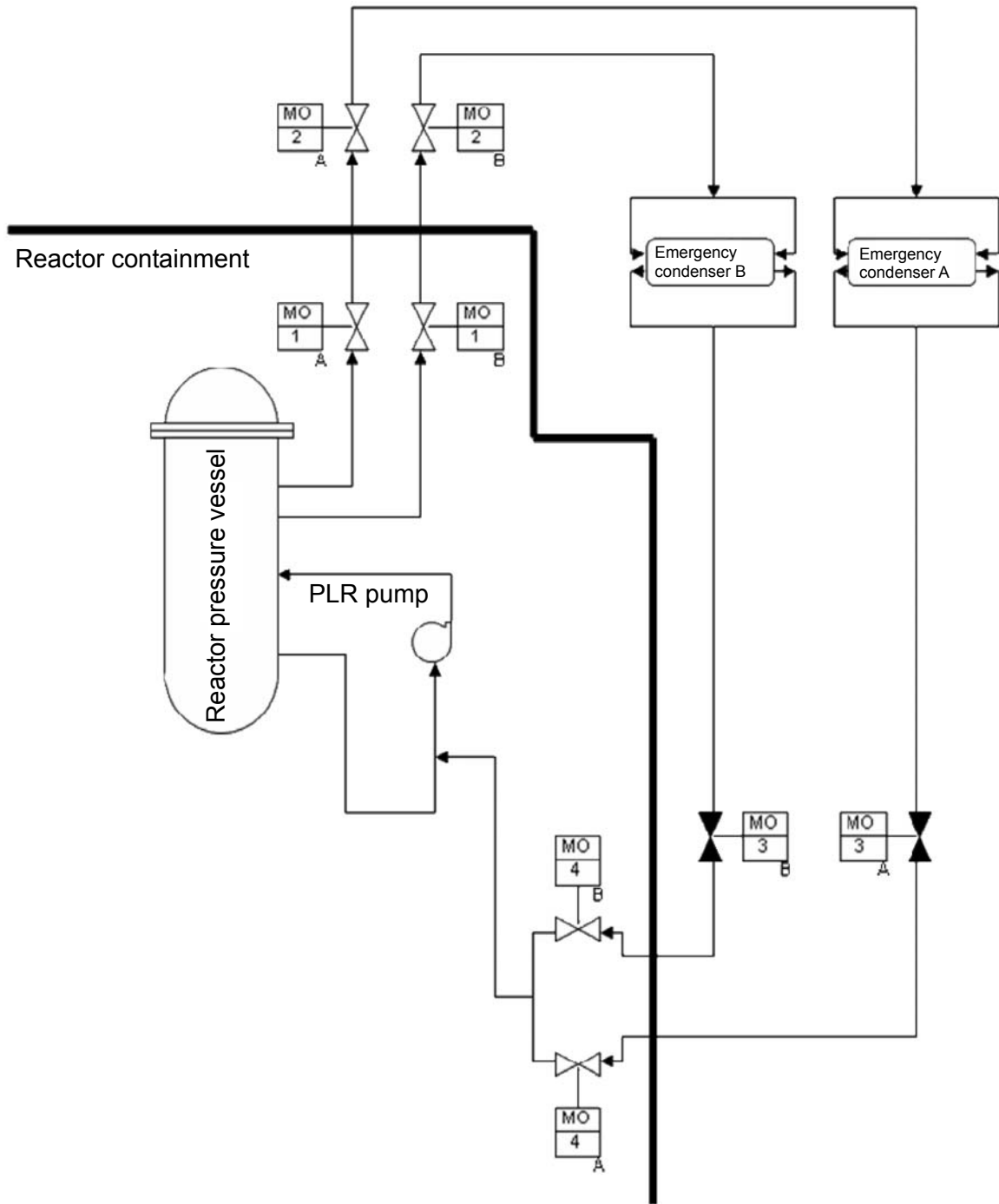
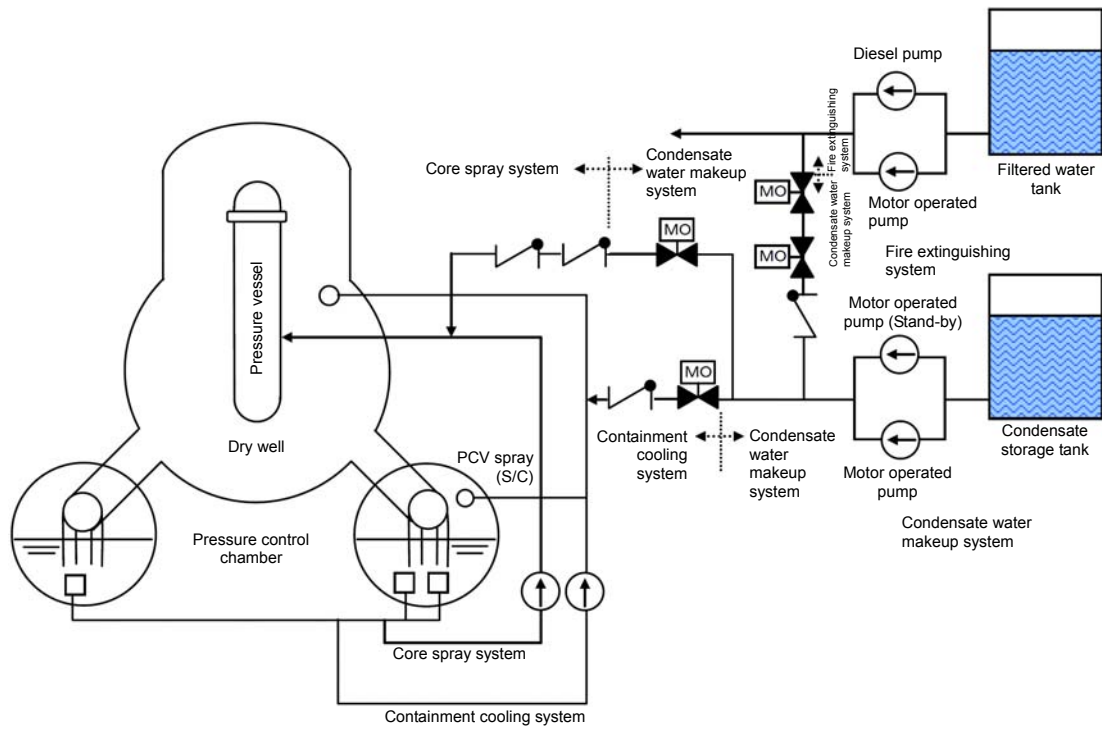
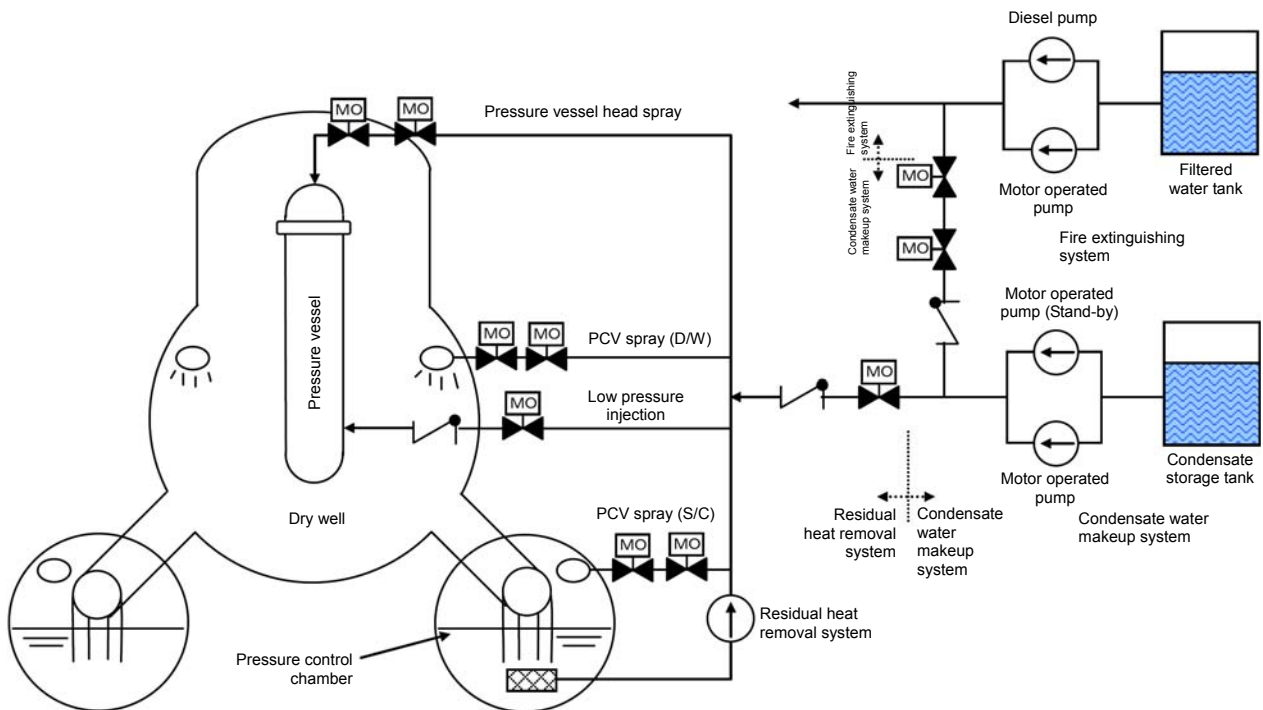

Figure Reference1-3 Emergency condenser



**Figure Reference 1-4 Alternative coolant injection system (Unit 1)**



**Figure Reference 1-5 Alternative coolant injection system (Units 2/3)**

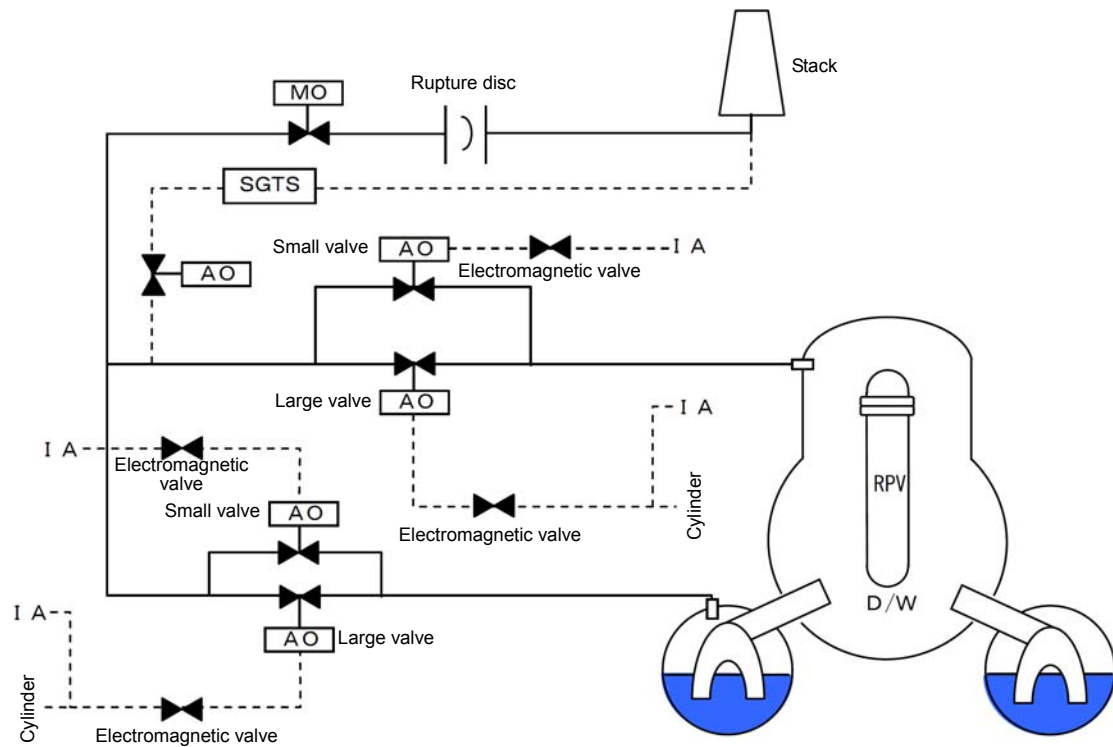

**Figure Reference1-6 Pressure resistant reinforced vent system (Unit 1)**

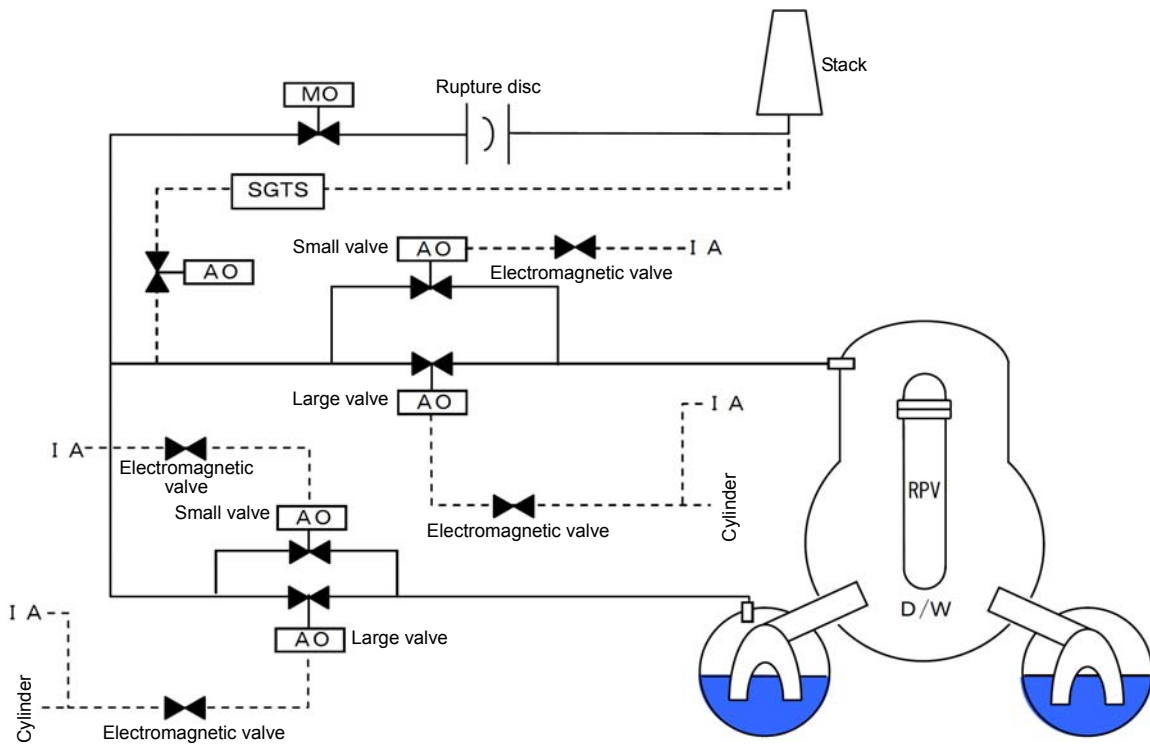

**Figure Reference1-7 Pressure resistant reinforced vent system (Units 2 / 3)**

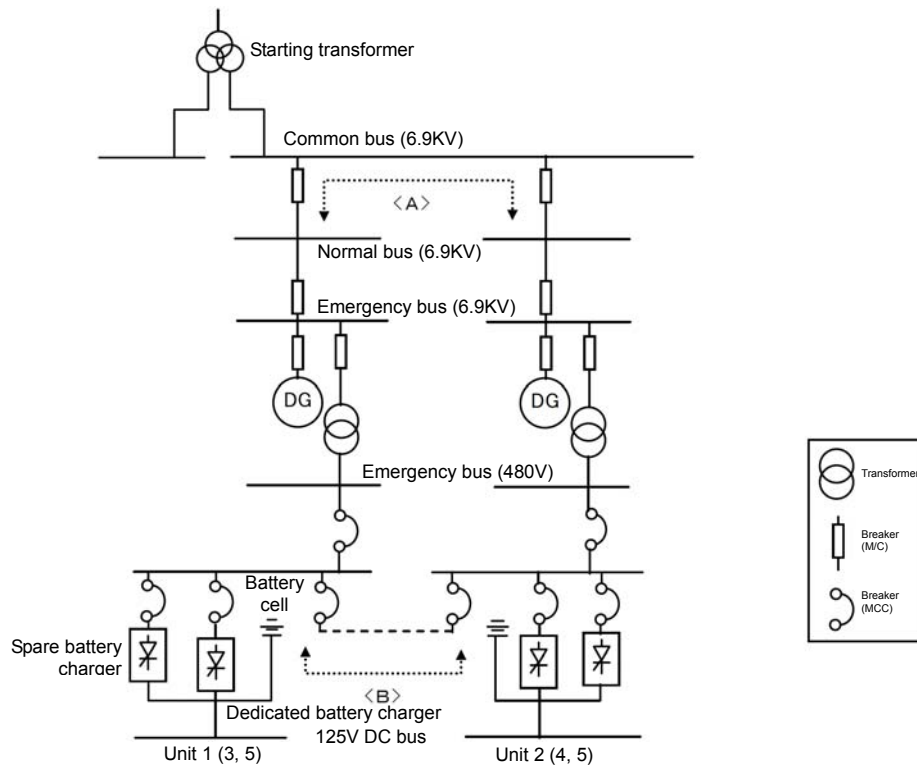

- <A> Route: Interchanges 6.9KV AC power source.  
(Operation at M/C is possible only if DC power is available)
- <B> Route: Interchanges 480V AC power source.  
(MCC is manually operated. MCC is normally open and its access is controlled by key lock.)

**Figure Reference 1-8 Power source interchange**

