

Examination of Accident at Tokyo Electric Power Co., Inc.'s Fukushima Daiichi Nuclear Power Station and Proposal of Countermeasures

October 2011

Japan Nuclear Technology Institute

**Examination Committee on Accident at Fukushima Daiichi Nuclear
Power Station**

Revision History

Revised Date	Revised Part	Revised Content	Note
October 27, 2011	All pages	New	
October 28, 2011	All pages	Correction of errors in writing, making descriptions appropriate	
December 16, 2011	2-10 2-13 to 2-15 2-17 3-27, 4-11 4-1 to 4-2 Appendix-2	Added a description about integrity of the piping function after the earthquake Added a figure showing integrity of the piping function Correction of descriptions Added a description about a hydrogen leaking route Added a description about loss of DC power supply Matching of comment described pages	

Introduction

We, the Examination Committee on Accident at Fukushima Daiichi Nuclear Power Station, recognize that the accident at Tokyo Electric Power Co., Inc.'s Fukushima Daiichi Nuclear Power Station (hereafter called Fukushima Daiichi) caused by the Great East Japan Earthquake has shaken the foundation of the Japanese nuclear industry, and damaged the credibility of Japanese nuclear engineers. It has therefore made people deeply skeptical of the morale of the engineers who could not prevent the accident.

It is widely known that the direct cause of the accident was the tsunami which was far larger than had been anticipated when the power station was designed. The assumptions made at the time of designing the plant had been based on scientific data that were then the latest. However, it is true that the plant had insufficiently prepared for the worst case in which a tsunami far larger than anticipated might occur. As a result, the cores of Unit 1 to Unit 3 melted one after the other and radioactive materials were emitted into the environment to a degree as high as level 7 of the International Nuclear Event Scale (INES). We are very sorry that the accident caused a great deal of anxiety to the people living around the power stations that had understood and supported the operation of the power stations but were now forced to evacuate and live in unspeakable hardship.

The situation at Fukushima Daiichi has been stabilized for now thanks to the intensive work of the Self-Defense Forces, police, firefighters and local governments; desperate struggle of the power station staff and the employees of cooperative companies; the cooperation of each electric power company in neighboring monitoring; and various support and equipment provided by plant makers in Japan and overseas. Nevertheless, we still have to expect that it will be quite a long time until we can restore the surrounding environment.

Meanwhile, there is growing concern about the safety of nuclear power stations which were not directly affected by the Great East Japan Earthquake too, and stations located in populated areas. Therefore, the power stations that were stopped for periodical inspection or to investigate the causes of trouble or implement countermeasures still have not restarted even though the prescribed inspection or construction has finished. This is in part because the general public does not sufficiently understand the explanation of the situation given by the nation or electric companies. Therefore, the supply and demand balance of electricity in the summer was tight in many areas throughout the country, though this was narrowly overcome thanks to the efforts made by companies and individuals to save electricity, and the substitute use of thermal power stations.

A stable energy supply is the basic premise of our national economy and, in Japan where energy resources are scarce, the necessity of a stable power supply provided by nuclear power stations will not change at all in the future.

We think that the most overriding priority for the nuclear power industry is to calmly analyze the cause of the accident by returning to its origin, taking as many lessons as possible from the analysis. It must then use those lessons to improve the safety of Japanese nuclear power stations and, by doing so, make the efforts of the industry known to society.

In the case of Japanese nuclear power stations, emergency measures have been implemented twice at the initiative of supervising governmental bodies. However, some people living near nuclear power stations say that the correlation between the measures taken as the emergency measures and the cause of the accident or the passage of

events seen at Fukushima Daiichi is not clear. And they are not convinced that such measures can prevent an accident that would threaten the lives of neighboring people like that of the Fukushima Daiichi Nuclear Power Station did.

Under the circumstances mentioned above, detailed data on the plant behavior or analysis results were publicized by Tokyo Electric Power Co., Inc. during this period, which was almost half a year after the accident. In addition, the Japan Nuclear Technology Institute (JANTI) has established the "Accident Examination Committee" within the institute, convening many experts from inside and outside the nuclear power industry in addition to the experts of the JANTI as if collecting all of the power of the industry. It aims to clarify the view of the industry, analyze the sequence of events noticed at the accident site and the cause of the accident, extract lessons to be learned and, based on the lessons obtained put together measures which are likely to enhance the safety of nuclear power stations as the committee's proposal.

We, the Accident Examination Committee, asked the professionals of the "Nuclear Power Safety Professional Committee, Technology Analysis Subcommittee" within the Atomic Energy Society of Japan, which is the only academy to totally deal with nuclear power issues, to review our proposal. It will check if there were elements we overlooked or unreasonable points which were inconsistent with the measures to be taken.

The examination conducted this time is limited to the events which happened at the power station site during approximately the 5 initial days including the occurrence of the earthquake, the coming of the tsunami and the following core melting and hydrogen explosion. The purpose is to find a way to prevent core melting and the following emission of radioactive materials to the environment. We are of the opinion that if each company seriously takes up the measures described in this report, much stronger nuclear power stations can be built with multiple safety measures which can resist tsunami which are much bigger than the design grade, like the one that hit the Fukushima Daiichi Nuclear Power Station. However, we know that there are some points that have still not been clarified among the events that happened at Fukushima Daiichi Nuclear Power Station. Hence, we believe we need to review this report and add new findings whenever new information comes to light from now on. Furthermore, concerning the behavior of radioactive materials around power stations and the reaction of people concerned too, we need to analyze the lessons to be learned and study proposals for improvement.

The biggest lesson learned from this accident is that we must always review the safety measures imagining what will happen when there are events that exceed the conditions considered in designing or operating plants, and what measures are to be taken to ease the impact of such events. And we believe that the first step in restoring the credibility of nuclear power stations or of engineers working for nuclear power, i.e., the credibility lost in this accident, is to seriously continue to implement such measures and make the situation known not only to professionals but also to the general public.

We would greatly appreciate any opinions or comments you may have on this report.

October 2011

Examination Committee on Accident at Fukushima Daiichi Nuclear Power Station
Chief Examiner, Takashi Dodo

Members of the Examination Committee

Deliberation Members of the Examination Committee on Accident at Fukushima Daiichi Nuclear Power Station

(Title omitted, position at the time of deliberation)

Chief examiner	Japan Nuclear Technology Institute, Executive Director	Takashi Dodo
	Hokkaido Electric Power Co., Inc., Nuclear Power Division Nuclear Fuel Control Office, Nuclear Power Technology Group Leader	Tomohiro Kodaira
	Tohoku Electric Power Co., Inc., Thermal Nuclear Power Headquarters Nuclear Power Division (Nuclear Power Technology), Section Manager	Tsunehiro Tada
	Chubu Electric Power Co., Inc., Nuclear PowerHeadquarters, Nuclear Powder Division Safety Technology Group Manager	Kouhiro Takeyama
	Hokuriku Electric Power Co., Inc., Nuclear Power Headquarters, Nuclear Powder Division Vice Manager (in charge of Technology and Quality Assurance)	Toshihiko Takahashi
	Kansai Electric Power Co., Inc., Nuclear Power Business Headquarters Nuclear Power Technology Division Manager	Hirohiko Yoshida
	Chugoku Electric Power Co., Inc., Electric Power Supply Business Headquarters (in charge of Nuclear Power Construction Electric Design) Manager	Yuichi Ida
	Shikoku Electric Power Co., Inc., Nuclear Power Headquarters Nuclear Power Division, Operation Group Leader	Masahiko Sato
	Kyushu Electric Power Co., Inc. Nuclear Power Generation Headquarters, Safety Technology Group Manager	Kazuaki Umada
	Japan Atomic Power Co., Inc., Power Generation Management Office Technology, Safety Group Manager	Satoru Fukuyama
	Japan Nuclear Fuel Limited, Safety Technology Office Safety Technology Division, Safety Technology Group	Tadashi Makihara
	Electric Power Development Co., Ltd. Nuclear Power Business Headquarters, Nuclear Power Construction Division, Assistant Manager	Sadayuki Kuramoto
	Toshiba Corporation Nuclear Power Fukushima Restoration Technology Division Manager	Mamoru Hatazawa
	Hitachi-GE Nuclear Energy, Ltd. Engineering Manager	Kumiaki Moriya
	Mitsubishi Heavy Industries Co., Ltd. Nuclear Power Business Headquarters, Safety Enhancement Measures Promotion Office, Office Manager	Yoshihiko Kato

Report Study Members of the Examination Committee on Accident at Fukushima Daiichi Nuclear Power Station

(Title omitted, position at the time of deliberation)

Hokkaido Electric Power Co., Inc.	
Nuclear Power Division, Nuclear Power Facility Group	Katsumi Dazai
Nuclear Power Division, Nuclear Fuel Control Office, Nuclear Power Technology Group	Shinichiro Yasui
Tohoku Electric Power Co., Inc.	
Thermal Nuclear Power Headquarters, Nuclear Power Division (in charge of Safety Enhancement) Section Manager	Kouji Tadakuma
Thermal Nuclear Power Headquarters, Nuclear Power Division (Nuclear Power Technology) Vice Manager	Daisuke Sato
Thermal Nuclear Power Headquarters, Nuclear Power Division (Nuclear Power Technology)	Jun Takaishi
Chubu Electric Power Co., Ltd.	
Nuclear Power Headquarters, Nuclear Power Division, Operation Group, Section Manager	Tetsuya Watanabe
Nuclear Power Headquarters, Nuclear Power Division, Safety Technology Group, Section Manager	Kazuyuki Matsumoto
Nuclear Power Headquarters, Nuclear Power Division, Safety Technology Group	Akihiro Urano
Hokuriku Electric Power Co., Inc.	
Nuclear Power Headquarters, Nuclear Power Division, Nuclear Fuel Technology Team	Seishi Arakawa
Nuclear Power Headquarters, Nuclear Power Division, Nuclear Power Facility Management Team	Junichi Nishii
Nuclear Power Headquarters, Nuclear Power Division, Nuclear Power Generation Operation Team	Akira Ohbata
Kansai Electric Power Co., Inc.	
Nuclear Power Business Headquarters, Plant Maintenance Technology Group Manager	Toshihiko Tanaka
Nuclear Power Business Headquarters Manager	Kensuke Yoshihara
Chugoku Electric Power Co., Inc.	
Electric Power Supply Business Headquarters (in charge of Nuclear Power Construction Electricity Design) Sub Manager	Takatsugu Takatori
Electric Power Supply Business Headquarters (in charge of Nuclear Power Construction Safety) Sub Manager	Takeo Makino
Shikoku Electric Power Co., Inc.	
Nuclear Power Headquarters, Nuclear Power Division, Operation Group Sub Leader	Daisuke Mizobuchi
Kyushu Electric Power Co., Inc.	
Nuclear Power Generation Headquarters, Power Generation Management Group	Tsuyoshi Muto
Japan Atomic Power Co., Inc.	
Power Generation Management Office, Plant Management Group, Sub Manager	Masashi Nachi
Power Generation Management Office, Technology, Safety Group Chief	Masaru Yamanaka
Japan Nuclear Fuel Limited	
Safety Technology Office, Safety Technology Division, Safety Technology Group	Tadashi Makihara
Electric Power Development Co., Ltd.	
Nuclear Power Business Headquarters, Nuclear Power Construction Division, Facility Technology Group	Kouzou Miyao

Toshiba Corporation Power Systems Company, Nuclear Power System Design Division	Hirohide Oikawa
Hitachi-GE Nuclear Energy, Ltd. Nuclear Power Planning Division, Nuclear Reactor Planning Group, Chief Engineer	Kohei Hisamochi
Mitsubishi Heavy Industries Co., Ltd. Nuclear Reactor Safety Technology Division Manager	Shigemitsu Umesawa
Nuclear Reactor Safety Technology Division, Safety Technology Control Group Manager	Hisanaga Takahashi
Nuclear Reactor Safety Technology Division, Safety Technology Control Group	Mitsuhiro Kano
Japan Nuclear Technology Institute Director, Operating Experience Analysis Division Manager	Masuhiko Nakano
Observer Tokyo Electric Power Co., Inc., Nuclear Power Operation Management Division Manager	Takeshi Takahashi
Federation of Electric Power Companies of Japan, Nuclear Power Division Sub Manager	Tai Furuta

Report Review Team of the Examination Committee on Accident at Fukushima Daiichi Nuclear Power Station

(Japan Nuclear Technology Institute)

Board Members

Director, General Affairs Division Manager	Akio Fukuda
Director, Safety Culture Division Manager	Etsuji Obu
Director, Codes and Standards Division Manager	Hiroyuki Ito
Consultant	Tamihei Nakamura Hiroaki Kawashima
Planning Office	Nobuyuki Kitamura Toshiki Nagasawa
General Affairs Division	Nobuyuki Onishi
Operating Experience Analysis Division	Ichiro Murakami Tomoyuki Yamazaki Kazuki Takada

Abbreviations

ADS	Automatic Depressurization System
AM	Accident Management
AOvalve	Air Operated Valve
APD	Alarm Pocket Dosimeter
ASW	Auxiliary Sea Water System
BAF	Bottom of Active Fuel
BWR	Boiling Water Reactor
CCS	Containment Cooling System
CRD	Control Rod Drive
CS	Core Spray system
CST	Condensate Storage Tank
CWP	Circulating Water Pump
D/D FP	Diesel Driven Fire Pump
DG	Diesel Generator
D/W	Drywell
DWC	Drywell Cooling System
ECCS	Emergency Core Cooling System
EECW	Emergency Equipment Cooling Water system
FCS	Flammability Control System
FP	Fire Protection system
FPC	Fuel Pool Cooling and Filtering system
HPCI	High Pressure Coolant Injection System
HPCS	High Pressure Core Spray System
HPCW	HPCS Closed Cooling Sea Water System
IA	Instrument Air-System
IC	Isolation Condenser
ITV	Industrial Television
M/C	Metal-Clad Switch Gear
MCC	Motor Control Center
MCR	Main Control Room
MOvalve	Motor Operated Valve
MP	Monitoring Post
MSIV	Main Steam Isolation Valve
MUWC	Makeup Water System (Condensated)
MUWP	Makeup Water system (Purified)
O.P.	Onahama Pile
P/C	Power Center
PCIS	Primary Containment Isolation System
PCV	Primary Containment Vessel
PSA	Probabilistic Safety Analysis
PWR	Pressurized Water Reactor
R/B	Reactor Building
RCIC	Reactor Core Isolation Cooling System
RCW	Reactor Building Closed Cooling Water System
RHR	Residual Heat Removal System
RHRC	RHR Cooling Water System

RHRS	RHR Sea Water System
RPV	Reactor Pressure Vessel
RSW	Reactor Building Closed Cooling Sea Water System
S/C	Suppression Chamber
S/P	Suppression Pool
SA	Severe Accident
SBO	Station Black Out
SFP	Spent Fuel Pit (Cooling System)
SGTS	Stand-By Gas Treatment System
SHC	Shutdown Cooling System
SLC	Stand-by Liquid Control
SRV	Safety Relief Valve
T/B	Turbine Building
TAF	Top of Active Fuel
TSW	Turbine Building Closed Cooling Water System
UHS	Ultimate Heat Sink

Glossary

Accident Management	(Measures against severe accidents) AM
Measures which are taken by effectively utilizing the safety allowance and the expected functions of the safety design in the existing design, other functions than the duly expected functions and devices which have been newly set up for such accidents in order to prevent a beyond design-basis accident which could lead to major core damage from expanding to a severe accident or to mitigate its impact in the event that the accident has developed to a severe accident.	
Air operated valve	AO valve
Valves which operate with compressed air	
Alarm Pocket Dosimeter	APD
A personal radiation monitor with an alarm using a semiconducting detector. It can record the name and time of the operation the carrier is engaged in.	
Alternative containment vessel spray	
It refers to the spray function for the containment vessel, effectively utilizing the existing condensate water makeup system and the water source and pumps of the fire service's water system.	
Alternative control rod insertion	
To shut down the reactor by automatically inserting the control rods after detecting an abnormality (high pressure, low water level in the reactor) by the instrumentation and control system, which is installed aside from the existing emergency shutdown system.	
Alternative reactivity control	
To conduct the recirculation pump trip and insert control rods by water level and pressure of the reactor with the use of an RPS signal.	
Alternative water injection	
It sprays water and removes heat when the emergency core cooling system does not function for some reason. In accordance with the original function, there is water injection to the high-pressure reactor and cooling of the containment vessel. A control rod drive hydraulic control system and reactor coolant clean-up system are used to conduct alternative water injection to the high pressure reactor, and the condensate make-up water system, the fire protection system, dry well cooler and the containment & vessel cooling water system are used to cool the containment vessel.	
Automatic depressurization system	ADS
One of the emergency core cooling systems, it refers to the back-end unit of the high pressure core spray system or the high pressure coolant injection. Its purpose is to lower the reactor pressure and facilitate the water injection of the low pressure injection system by opening the main steam relief safety valve installed in the main steam line.	
Auxiliary seawater system	ASW
A system for feeding seawater to the heat exchangers for the facilities which feed cyclically cooling fresh water to the process heat exchangers, bearing coolers and air-conditioners in the plant.	
B equipment	
Equipment which has to be worn when entering zones that could be contaminated with radioactive substances.	
Back wash valve pit	
A place where valves are installed for reversing the flow of the seawater in the tube to clean the condenser tubes.	

Boiling water reactor	BWR
It mainly uses enriched uranium as nuclear fuel and water as a moderator and coolant. Steam is sent directly to the steam turbine without going to the heat exchangers. The steam which contains radioactive substances is sent to the steam turbine.	
Bottom of active fuel	BAF
Bottom of the fuel assembly.	
Charcoal filter	
A filter filled with granular activated charcoal to remove the radioactive iodine. While iodine is removed by activated charcoal by the effect of physical absorption, it is often the case that some chemical material is added to the activated charcoal in order to absorb iodine compounds that are difficult to absorb such as methyl iodide.	
Circulating water pump	CWP
Steam that has been used in the main turbine is cooled down and condensed in the main condenser. Seawater is used to cool down the steam and is fed to the seawater system (circulating water system) by this pump.	
Cold shutdown	
It refers to the condition where the temperature of the core water is less than 100°C and the reactor mode switch is placed in "Start-up," "Shutdown" or "Refueling."	
Condensate and feed water system	
A system for pressurizing and heating condensate steam condensed by the condenser and feeding it to the reactor.	
Condensate storage tank	CST
A tank for storing the water of the condensate water system. It is used for feeding condensate, storing surplus condensate and make-up water and others. In BWR, it is used as water source for the emergency core cooling system.	
Condenser	
Seawater cooler for condensing the steam which has acted in the steam turbine. It reduces the final pressure of the turbine drive steam by the obtained high vacuum and expands the heat drop resulting in the improvement of the turbine efficiency.	
Constant rated electric power operation	
An operating mode to maintain a steady level of electric power output.	
Constant rated thermal power operation	
An operating mode to maintain a steady level of thermal power, in which the electric power output fluctuates depending on the environmental conditions such as the seawater temperature.	
Containment Cooling system	CCS
A device to cool down the energy of the coolant leakage and the decay heat of the fuel by spraying water in the containment vessel in order to prevent the pressure and temperature of the inside the containment vessel from exceeding the maximum operating temperature at the time of a loss of coolant accident. At the same time, it helps eliminate iodine in the containment vessel and reduce iodine leakage from the containment vessel.	
Control rod drive	CRD
A device for taking control rods into and out of the reactor core. Hydraulically-powered drives are generally adopted for BWRs. (For advanced BWRs, electrically powered drives are also used concurrently.)	

Control room air handling and ventilation system	
A system for maintaining a clean atmosphere in the control room by automatically isolating the room from the external air and by recirculating the air in the room, when a leakage of radioactive material takes place.	
Core	
It refers to the area where nuclear fuel is located and the chain reaction of nuclear fission takes place in the reactor. It consists of nuclear fuel and a moderator, among which coolant is traveling.	
Core spray system	CS
A system which is part of the emergency core cooling system of a BWR. It sprays water to the upper part of the fuel to cool it down at the time of a loss of coolant accident.	
Decay heat	
Heat generated when the atomic nucleus of a radioactive substance spontaneously transforms to another atomic nucleus.	
Demineralized water tank	
Tank for storing the demineralized water which is obtained by demineralizing the water from rivers or dams with the use of a demineralizer. It is used for the system that needs water of which quality is controlled.	
Diesel driven fire pump	D/D FP
Diesel driven pumps installed in the fire protection system. They are automatically to start, when the pressure in the fire protection system becomes low or electric-motor-driven fire pump cannot operate.	
Diesel generator	DG
A generator which feeds power to facilities necessary to safely shut down the power plant at the time of loss of normal power of the plant. It is driven by a diesel engine.	
Disconnect switch	
A device to disconnect the circuit for the safe checking work. Its capability to disconnect is originally low and basically it cannot switch the load current. It is equipped with an interlock so that equipment operation is not possible unless the breaker is open.	
Dry well	D/W
Space other than the suppression chamber in the containment vessel.	
Dry well cooler	DWC
Facility which cools the dry well while the reactor is operating and also cools during the periodical inspection to avoid a severe temperature rise in the containment vessel.	
Duct	
It serves as path for air or as a flow channel for water and gas.	
Dust extractor	
A device for extracting dust contained in the obtained seawater.	
Earthquake-proof class	
Classes according to the importance of the facility, determined in the importance classification concerning the aseismic design.	
Electric magnetic valve	
A valve which is opened and closed by the electromagnetic power.	

Emergency core cooling system	ECCS
Engineered safety features intended to effectively cool down the reactor core even when a loss of coolant accident takes place in the reactor. It has a volume sufficient to cool down the reactor core, regardless of the size of the pipe rupture on the primary cooling system for the reactor. It is comprised of a high pressure core spray system, high pressure coolant injection system, low pressure core spray system, low pressure core injection system and automatic depressurization system. (In the case of advanced BWR, the reactor core isolation cooling system is included in the ECCS.)	
Emergency equipment cooling water system	EECW
A facility to feed the cooling fresh water to emergency diesel generators and the coolers of emergency ventilation equipment so that every piece of emergency equipment can maintain its required function at the time of a loss of coolant accidents. (It also feeds the cooling water to residual heat removal pump motor.)	
Engineered safety features	
It refers to the facilities designed to have functions to contain or prevent the release of considerable radioactive material caused by a fuel failure or such like in the reactor, which are brought about by some damages or failure to the reactor facilities.	
Enhanced pressure resistant vent	
A containment vessel vent line of high pressure resistance, which was prepared as measures against severe accidents. There are two vent lines for D/W and S/C, each of which has big and small valves of AO valve. After the confluence of two lines, the MO valve and the rupture disk are placed and the converged line further connected to the vent stack. The word "containment vessel vent" in this report refers to the vent from this enhanced pressure resistant vent line.	
Fail-safe	
To ensure safety even when a failure occurs. It means that devices are designed to keep safety without endangering the original function even when part of the device fails or a failure takes place in the function of the safety protection device.	
Filtered water	
Water from rivers or dams is used after processing as the water for the plant. It is used in the systems which do not need high quality water.	
Fire protection system	FP
Fire protection system in a power plant. Besides the normal fire hydrants, carbon dioxide extinguishing systems for oil fires and others are available.	
Fire-resistant clothes	
Clothes which are difficult to burn.	
Flashing	
To wash radioactive substances away from piping with clean water to reduce the dose.	
Fuel Pool Cooling and Filtering system	FPC
Fuel assemblies taken out of the reactor need to be cooled down in the fuel pool, because the fission products they contain emit heat and radiation. It is a purification system for removing the impurities and maintaining the water quality, while cooling down the water of the pool.	
Fuel cladding tube	
A thin-walled circular pipe used as cladding material for the fuel rod. A zirconium alloy or a stainless steel pipe is adopted. Fuel cladding tubes are placed between fuel and coolant and play an important role in maintaining the integrity of the fuel. It is one of the five layer barriers and dissolved when reaching a temperature of 1800 degrees.	

Fuel day tank	
Light fuel oil, which is fuel for emergency diesel generators, is transferred from the light oil tank outside to the fuel day tank located in the building where the emergency diesel generators are found. A necessary stockpile for each tank according to the operation time is decided in safety regulations.	
Full-face mask	
One of the purification respiratory protection tools. It covers all of the face.	
HPCS Closed Cooling Sea Water System	HPCW
A system which feeds seawater to the heat exchanger of the facilities which cyclically feed freshwater to the cooler for the motors of the high pressure core spray system, bearings and oil cooler.	
Heat sink	
A cooling source for securing the heat removal function (heat release).	
High pressure coolant injection system	HPCI
One of the emergency core cooling systems, which, with the use of steam-turbine-driven high pressure pump, injects cooling water into the reactor core in the time of the accident where the break of the piping is relatively small and the reactor pressure does not rapidly fall. The flow (i.e., capacity) of the pump is approximately 10 times larger than that of the reactor core isolation cooling system, but smaller than that of the reactor shutdown cooling system and the residual heat removal cooling system (approximately 1800 m ³ /h, for Units 2 to 5 of the Fukushima Daiichi Nuclear Power Station). It is installed in Units 1 to 5 of the Fukushima Daiichi Nuclear Power Station.	
High pressure core cooling function	
High pressure core cooling function including the high pressure core spray system, the high pressure coolant injection system and others.	
High pressure core spray system	HPCS
One of the emergency core cooling systems, which has an independent power source (diesel generator) in the time of the accident in which the reactor pressure does not rapidly fall and sprays with the use of an electric-motor-driven high pressure pump to the reactor core for cooling.	
In-core instrumentation piping	
Instrumentation and equipment for measuring in the reactor the process volume needed for monitoring the control, safety and conditions of the reactor. It is a general name for an in-core neutron flux monitoring system, coolant flow monitoring system, control rod position monitoring system and others.	
Independence	
To design a system for operation and system for safety separately so that a failure on one system does not affect the other.	
Industrial television	ITV
TV camera installed for reducing the exposure of the plant worker, monitoring the operation and leakage of radioactive fluid, monitoring the alarm of the local control panel, monitoring the situation of the water intake structure in the winter time and others. Cameras installed for site monitoring in the industry are generally called ITV.	
Inflammability limit	
Breaking point of the gas concentration of hydrogen and oxygen generated by metal-water reactions or radiolysis of water in the time of the loss of coolant accident, above which combustion occurs.	
Instrument air system	IA

A system which feeds the clean and dry compressed air for the air operated valves, air-regulated devices and measuring instruments.	
Iodine preparation	
<p>Since the thyroid has a function to absorb and accumulate iodine, radioactive iodine is instantly combined with the thyroid hormone in the thyroid, which keep emitting the radiation inside the body, once the radioactive iodine in the atmosphere is absorbed in the human body. As a result, disorder of the thyroid gland caused by the radiation leads to development of goitrous tumor or hypothyroidism as late radiation injury.</p> <p>In order to prevent this disorder, people need to take iodine without radiation before being exposed in order to saturate thyroid with iodine without radiation so that the thyroid with radiation is not be taken into the thyroid, even if exposed internally. Thus a preventive effect can be expected.</p>	
Isolation condenser	IC
A heat removing device for the reactor at the time of the isolation of the core in the boiling water reactor. It cools down the reactor steam with the water of the secondary system and returns the condensate to the reactor by natural circulation. (Only installed for the Fukushima Daiichi Nuclear Power Station and Unit 1 in the Tsuruga Power Station.)	
Leak	
Leakage	
Loss of coolant accident	
One of the credible accidents of the reactor. In this accident coolant in the reactor pressure vessel is lost because of the damage of piping or other reasons. Cooling of the reactor is not possible because the coolant is lost from the reactor pressure vessel.	
Low pressure core cooling system	
Low pressure emergency core cooling systems. They include a low pressure core injection system, low pressure flooder system, low pressure core spray system and others.	
Lower plenum	
Space found in the lower part of a reactor core. During normal operation, water which flows down between the inside wall of the reactor pressure vessel and the core shroud or along the primary loop recirculation system to this space, where it turns back into the core to cool down. In the lower plenum, monitoring guide tubes and control rod guide tubes are found.	
Main control room	MCR
A room where a main control board, on which monitoring and operating devices necessary for the operation of the main system of the plant are collected, is placed and plant workers carry out the monitoring, control and operation in a centralized manner.	
Main steam isolation valve	MSIV
Valves installed in the main steam line, which close up when it is needed to isolate the reactor from the turbine facility.	
Makeup Water System (Condensated)	MUWC
A system for feeding the various types water (The water source is the condensate storage tank. The water is the purified water which has been used in the reactor. Though it contains some amount of radioactive substance, its dose is low.) necessary for operation of the plant by using pumps (condensate water transfer pump). It is not for emergency, but it is injected to the reactor in the implementation of the accident management. The flow volume of the pumps is smaller than those of the reactor core isolation cooling system (approximately 70 m ³ /h).	
Makeup Water System (Purified)	MUWP
A system feeding to the equipment, piping, valves and others installed in buildings, auxiliary facilities and others the make-up water with necessary volume and pressure, which is needed for the smooth operation and maintenance of a power plant.	

Maximum response acceleration	
Maximum value of acceleration of the vibration (response) of the structure when the seismic motion acts on that structure.	
Melted fuel	
Fuel assembly melted by high temperature, which became a lump.	
Metal-clad switch gear	M/C
A power panel used for high-voltage circuit in the plant, in which the electromagnetic breakers, vacuum breakers, protective relay and auxiliary instruments are compactly housed. It consists of regular, common and emergency switches.	
Metal-water reaction	
When zirconium used for the fuel cladding is heated, it gradually reacts with the surrounding coolant, which is water and becomes oxidized. This reaction produces hydrogen gas.	
Monitoring post	MP
They are placed in several places in the plant and monitor the rate of atmospheric gamma dose. The vehicle which can monitor is called monitoring car.	
Motor control center	MCC
A power panel used for low-voltage low-voltage circuits in the plant, in which line breakers, magnetic contactors and protective relay are compactly housed. It consists of regular, common and emergency switches.	
Motor operated valve	MO valve
A valve whose driving parts for opening and closing are operated by a motor.	
Multiplicity	
To prepare more than two systems or pieces of equipment of the same function and the same quality.	
Nonessential	
A system used normally	
Nuclide	
A term used to refer to types of atom or nucleus.	
Nuclide analysis	
To identify radionuclide from sample	
Off-site Center	
Facilities predesignated by the competent minister provided in Paragraph 1, Article 12 of the Special Law of Emergency Preparedness for Nuclear Disaster in order that the related personnel from the national, prefectural and municipal governments and other organizations meet together and that the local nuclear emergency response headquarters of the national government and the disaster countermeasures headquarters of the prefectural governments share the information in the time of nuclear disasters with a view to conducting concerted emergency measures and promoting the coordinated and smooth implementation of nuclear disaster countermeasures. Its legally official name is the Emergency Response Operation Facilities.	
On-site power	
AC power distributed to equipment and others in a power plant.	
Onahama Pile	O.P.
Datum level 0.727 m lower than the Tokyo Pile.	
Paging	

A facility of in-house communication consisting of handset stations and speakers placed in many places in the plant. It is easy to use and enables clear broadcasting and telephone calls in a very noisy environment.	
Pellet	
A highly compacted small cylindrical substance containing the fissionable material. It is one of the five layer barriers. It is generally made by compacting the oxidation product with high pressure, sintering it and making it into ceramic form. A fuel rod is made by putting them into the fuel rod cladding.	
Pier	
A part of the port facilities in the plant. It is the place for unloading the cargo carried by ships.	
Pool gate	
Gates for separating the spent fuel pool, the reactor well and the steam-water separator pool. During the periodical inspection, the in-core structures such as steam-water separator are transferred to the steam-water separator pool and the loaded fuel is transferred to the spent fuel pool after removing the lid of the reactor pressure vessel. Since those pieces of equipment or devices have a very high dose, they are transferred from one pool to another under the water, securing a biological shield wall.	
Power center	P/C
A facility for controlling electromotor loads, motor control center loads and others of intermediate capacity less than 600 V source voltage at one place in a centralized manner. It is comprised by arranging in one board units into which air circuit breakers and protection equipment.	
Pressurized Water Reactor	PWR
Type of nuclear reactor in which water, which is used as moderator and coolant, is highly pressurized to suppress boiling of water. Primary cooling system that is to retrieve the thermal energy generated in the core and secondary cooling system that is to generate steam is completely separated by the heat exchanger (steam generator).	
Primary Containment Vessel Cooling Seawater System	
A system supplying seawater to the components of the containment cooling system	
Primary Containment Vessel Vent	PCV Vent
A device to decrease the pressure inside the PCV by partially releasing the gas containing radioactive materials (mostly nitrogen) from the PCV in order to prevent the pressure from increasing abnormally and to protect the PCV.	
Primary Containment Vessel	PCV
A vessel housing reactor-related components and piping including reactor pressure vessel. This vessel needs to have a capability to resist a transient pressure and temperature which occur in the time of pipe rupture accident of reactor-related piping (what is called a Loss of Coolant Accident) and to maintain the post-accident integrity and has the leak-tightness for minimizing the leakage of the radioactive material from the vessel as low as possible. This is one of the five-layer barriers.	
Primary containment isolation system	PCIS
This system operates so that the pressure vessel is isolated in the time of the fuel damage accidents, that the isolation valves between the reactor pressure vessel and the damaged part close to prevent radioactive materials and coolant from leaking in the time of a break accident on the primary system outside of the containment vessel and that the release path of radioactive materials is shut to contain them in the containment vessel in the time of a break accident on the primary system inside the containment vessel.	
Probabilistic Safety Analysis	PSA
To assess the safety in consideration of the probability of various possible events	

Process computer	
<p>A computer for performing the process control, monitoring and controlling the process volume and arithmetic processing. The connection with the plant process volume is performed through the process input-output units and generally highly reliable computers are used, because high operational availability and effectiveness are required. In the nuclear plant they are installed for monitoring the process volume, calculating the core performance and the plant performance and often applied as systems having the plant operation supporting function. They are installed with the diagnosis function.</p>	
RHR cooling water system	RHRC
<p>A system which feeds cooling freshwater to the heat exchangers and the pumps of the residual heat removal system, mechanical seal coolers of the pumps of the low pressure core spray system and others.</p>	
Rapid depressurization	
<p>An operation to decrease the reactor pressure by opening the main steam safety release valve manually in order to supply water from low-pressure emergency core cooling system into the reactor.</p>	
Reactor building	R/B
<p>A building housing a reactor and its related facilities. This is one of the five-layer barriers.</p>	
Reactor building closed cooling seawater system	RSW
<p>Cooling water of the reactor building closed cooling water system cools through a heat exchanger. This system is feeding seawater for cooling down the cooling water of the reactor building closed cooling water system.</p>	
Reactor building closed cooling water system	RCW
<p>One of the component cooling systems. Cooling system for reactor-related non-safety components or cooling system for reactor-related non-safety and safety components.</p>	
Reactor coolant pressure boundaries	
<p>It refers to the zone where during the normal operation, the reactor coolant is included and the same pressure condition as the reactor. It forms a pressure barrier for the primary cooling system, breakage of which leads to the loss of coolant accident. It usually includes the reactor pressure vessel, primary piping and others, but it does not refer to the part that is isolated in the time of the loss of coolant accident.</p>	
Reactor core isolation cooling system	RCIC
<p>During the normal operation, when the main condenser somehow cannot be used due to the close of the main steam isolation valve or other reasons, the turbine-driven pump should be operated by steam of the reactor to feed the cooling water to the reactor in order to remove decay heat of the fuel and reduce pressure. When the water feeding system is out of order, the system is used as auxiliary water feed pump to maintain water level of the reactor. Since the source of power is steam generated by the reactor, this system cannot be operated without a certain level of the reactor pressure. The source of water is either the condensate storage tank or the suppression pool. Since steam is discharged to the suppression pool after the start of the turbine, the temperature in the suppression chamber and the suppression pool rises during the operation of this system. Therefore the operation of this system needs to be coordinated with the residual heat removal system to prevent the temperature from rising.</p>	
Reactor mode switch	
<p>A switch for selecting the interlock according to the situation of the reactor. Modes include "Operation," "Start-up," "Shutdown" and "Refueling."</p>	

Reactor pressure vessel	RPV
A vessel in which a reactor core, in-furnace structure, primary coolant and others are housed and steam are generated by nuclear reaction of the fuel.	
(Reactor) Subcritical	
To stop the chain reaction of nuclear fission by totally inserting control rods, which is a shutdown function at the time of the reactor scram. It is possible to shut down the reactor safely by the subcritical operation.	
Receiving circuit breaker	
Device for isolating the troubled circuit when an accident occurs on the transmission network.	
Reference surface	
Water is held to take a reference pressure for measuring the water level inside the reactor pressure vessel.	
Residual heat removal seawater system	RHRS
Cooling water of the residual heat removal system cools through a heat exchanger. This system feeds seawater for cooling down the cooling water of the residual heat removal system.	
Residual heat removal system	RHR
<p>A system for removing and cooling the decay heat and the sensible heat generated by the core after the shutdown of the reactor. It is operated in the below-mentioned operation modes according to the composition of valves: Shutdown cooling system, Low pressure coolant injection system, Containment vessel spray system, Suppression pool cooling system and Spent fuel storage pool cooling system.</p> <p>It's often the case that the alternative water injection as a countermeasure against severe accidents injects water into the reactor or the containment vessel with use of the piping of the residual heat removal system.</p>	
Rupture disk	
Quaquaversal metal board which is intended for preventing the air-tight devices such as the pressure vessel, rotating devices, piping and ducts from breaking because of excessive or negative pressure. It is a safety device, which is to break at a designed pressure, to release the abnormal pressure in the facilities by rupturing.	
Safety relief valve	SRV
A valve which discharges steam to the suppression pool automatically or in a manual manner from the control room for protection of the reactor pressure vessel when the reactor pressure rises abnormally (discharged heat is cooled down and condensed in the suppression pool), and additionally has function of ADS (Automatic Depressurization System) of ECCS (Emergency Core Cooling System).	
Scram	
It refers to a prompt shutdown of the reactor by automatically inserting negative reactivity to the reactor, when the signals of the detectors installed in the reactor exceed the limit of the range of operational conditions. Normally it is caused automatically by the safety devices of the reactor. Setting items of the predetermined conditions for scram, which is called scram conditions, include abnormal increase of output of the reactor, seismic acceleration and turbine trip. It is a generic term for emergency shutdowns.	
Sea Water Heat Exchanger Building	
Building housing pumps supplying seawater to heat exchangers of various types of fresh water cooling system, heat exchangers and others.	

Self-air set	
One of the respiratory protection tools, which feeds air from a portable cylinder. It is used for preventing the holder, who is in the atmosphere of high concentration of radioactive materials, from inhaling radioactive materials in the air.	
Cesium iodide	
An inorganic compound whose composition formula is CsI. It is the metal halogen compound which consists of cesium, which is an alkali metal, and iodine, which is a metal halogen. For scientific purpose, it is used as an X-ray fluoroc-magnifying pipe and as single crystal for detecting gamma rays. It is also used in the simple radiation measuring device "Hakarukun." Radioactive iodine generated in the reactor is emitted from the core to the containment vessel as CsI and most of it is absorbed in water.	
Severe accident	
An event, in which sufficient cooling of the reactor core and control of the reactivity cannot be realized by the measures assumed by the assessment of the safety design, considerably exceeding the design basis event and resulting in significant damages of the reactor core. The significance of a severe event depends on the degree of damages or the degree of loss of integrity of the containment facility.	
Shared auxiliary operational facilities	
Shared spent fuel pool in the Fukushima Daiichi Nuclear Power Station and buildings housing the emergency diesel generators for units 2 and 4 of the Fukushima Daiichi Nuclear Power Station.	
Shroud	
A cylindrical structure housing fuel assemblies and control rods constituting the core part.	
Shutdown cooling system Shutdown cooling mode	SHC
Facility for removing decay heat by cooling the coolant (reactor water) with the use of pumps and the heat exchanger after the shutdown of the reactor. It has capability to implement the cold shutdown. The pump flow is large and the heat exchanger is highly capable. (All units other than Unit 1 in the Fukushima Daiichi Nuclear Power Station have the cooling system "Shutdown cooling mode" in RHR system.)	
Significant building with base isolation	
A building constructed to set up the disaster countermeasure headquarters when natural disasters such as earthquakes take place. It is made with the reinforced concrete structure and base isolation and consists of meeting rooms, communication facilities, power supply system, air-conditioners and others. It is designed so that the first break after the earthquake can be performed without any problems even when the earthquake of 7th seismic intensity.	
Simulator training	
Training on how to shut down safely a reactor by simulating transients and severe accidents with the use of computers.	
Skimmer level	
Water level of skimmer surge tank. Supernatant fluid of the spent fuel pool flows over the skimmer weir and is guided to the skimmer surge tank. It is needed to maintain the suction pressure of the pumps of the spent fuel pool cooling and purification system, and water quality of the pool by removing the floating objects from the pool surface.	
Special Law for Nuclear Emergency	
An abbreviated name for Special Law of Emergency Preparedness for Nuclear Disaster.	
Spectrum	
It generally refers to an array of components laid out in quantitative order of some characteristics after breaking down an object of complex compound into components.	

Spent fuel pit	SFP
A pool for storing fuel taken out from the reactor. Besides spent fuel, fuel taken out for the periodical examination, neutron source, damaged fuel and others are stored there. Water plays a role of biological shield and removes decay heat. Quality of water is maintained by the spent fuel storage pool and filtering system.	
Stack	
Facilities intended to discharge and diffuse the radioactive gaseous waste into the air. The discharge of radioactive gaseous waste is regulated by the stipulation of the law down to the predetermined volume, and it is discharged from stacks into the atmosphere.	
Stand-by gas treatment system	SGTS
A facility, which is one of the engineered safety features, to automatically shut down regular ventilation systems and reduce the external emission of the radioactive iodine and radioactive material in particulate form while keeping the negative pressure inside the buildings, when a radioactive leakage accident takes place.	
Stand-by liquid control	SLC
A back-end system of the control rod drive system, which shuts down the reactor by feeding sodium tetraborate solution which can absorb a lot of neutron when it is impossible to insert control rods for some reason.	
Standard earthquake ground motion (Ss)	
An earthquake ground motion employed in the seismic design of a nuclear power plant. It is the earthquake ground motion which is properly assumed to have a probability to, though extremely rarely, occur during the period of the operation and a significant impact on the facilities from the viewpoint of seismology and earthquake engineering considering geological condition and structure and earthquake activity in the vicinity of the site. Both hypocenter-specified and hypocenter-not-specified standard earthquake ground motions on the free bed-rock surface in the site are to be prepared in horizontal and vertical directions respectively. Safety functions of the aseismatically important facilities need to be maintained in the face of seismic force of these standard earthquake ground motions Ss.	
Station black out	SBO
A loss of AC power, which is a necessary source of power for the power plant, for some reasons. Source of AC power includes external power supplies and emergency diesel generators.	
Suppression Chamber, Suppression Pool	S/C, S/P
The systems, adopted only in Boiling Water Reactors (BWR), constantly hold water of approximately 4,000 m ³ (in case of units 2 to 4 of The Fukushima Daini Nuclear Power Station). In case that cooling water in the reactor pressure vessel is reduced by some accident and the steam pressure is increased, these systems decrease the pressure inside the pressure vessels by guiding the steam through the vent pipes to the pressure chamber to cool it down. They are also utilized as a source of water for the emergency core cooling system.	
Survey	
To explore the presence of radioactive material and measure its dose.	
Switching Station	
Staging station set up for transmitting electric power generated by electric power stations to the power supply system and for bringing it from power system into the plant. Switching of the power supply system is made by switches.	
Temperature falling rate	
Fall rate of temperature per hour.	

Thermocouple	
A sensor for detecting the temperature difference. When two different types of metal are connected, voltages according to the different temperature are generated at the two connecting points due to the different thermopower of each type of metal and an electric current flows in a certain direction. This is a temperature sensor using a phenomenon (Seebeck effect) in which thermoelectromotive force arises because of the temperature difference between the two connecting points of different types of metal.	
Top of active fuel	TAF
Zero point of the fuel level instrument. It refers to the top of the pellet of the fuel assembly.	
Torus room	
A room which houses the doughnut-shaped tunnel (suppression chamber) containing water source for the emergency core cooling system. Since the shape of this tunnel is called torus, the room housing is called torus room. In the torus room piping other than the suppression chamber are also installed. The torus room is placed at the lower part of the containment vessel, surrounding it.	
Total black out	
A loss of both AC and DC power	
Transient Phenomenon record Server	
A server which ceaselessly records data of main parameters of the plant operation, automatically stores the data before and after the event when their values exceed or fall below the manually or previously set ranges, and supports the event analysis afterwards.	
Trench	
A tunnel intended to lay cables between buildings.	
Turbine Building Closed Cooling Water System	TSW
A system for feeding seawater to the heat exchanger of the turbine auxiliary cooling water system, which cools down turbine auxiliaries bearing, oil coolers, air conditioners and others with circulating fresh water.	
Turbine building	T/B
A building for housing main turbines, generators, main condensers, reactor feed water pumps, turbine auxiliaries and others.	
Ultimate heat sink	UHS
A final disposal place which removes and releases the heat collected from the fuel (decay heat) and operating machines. Usually the heat is removed through heat exchangers and disposed in the sea.	
Vent line nap	
Composition of system for vent.	
Ventilation system of Primary Containment Vessel	
= drywell cooler	
Void	
Air bubbles generated when boiling.	
Water radiolysis	
Water is decomposed by irradiating ionizing radiation into hydrogen and oxygen.	
Zirconium-water reaction	
Same as metal-water reaction. When zirconium used for the fuel cladding is heated, it gradually reacts with the surrounding coolant, which is water, and becomes oxidized. Oxidized zirconium cladding becomes brittle and generates hydrogen.	

Table of Contents

Introduction	1
Members of the Examination Committee	3
Deliberation Members of the Examination Committee on Accident at Fukushima Daiichi Nuclear Power Station	3
Report Study Members of the Examination Committee on Accident at Fukushima Daiichi Nuclear Power Station	4
Report Review Team of the Examination Committee on Accident at Fukushima Daiichi Nuclear Power Station	6
Abbreviations	7
Glossary	9
Chapter 1 Purpose	1-1
Chapter 2 Fukushima Daiichi Nuclear Power Station Accident Development	2-1
2.1 Complete overview of Fukushima Daiichi Nuclear Power Station and accident	2-1
2.1.1 Overview of Fukushima Daiichi Nuclear Power Station	2-1
2.1.2 Overview of Great East Japan Earthquake and Tsunami	2-3
2.1.3 Overview of accident due to Great East Japan Earthquake	2-6
2.1.4 Impact of earthquake	2-11
2.1.5 Impact of tsunami	2-17
2.2 Course of accident at Unit 1	2-21
2.2.1 Conditions from earthquake to arrival of tsunami	2-21
2.2.2 Situation of nuclear reactor building from tsunami to hydrogen explosion	2-22
2.2.3 Condition of nuclear reactor building after hydrogen explosion	2-27
2.2.4 Main events after accident	2-28
2.2.5 Status of spent fuel pool	2-28
2.3 Course of accident at Unit 2	2-40
2.3.1 From occurrence of earthquake to arrival of tsunami	2-40
2.3.2 From arrival of tsunami to malfunctioning of pressure suppression chamber	2-40
2.3.3 Major events thereafter	2-45
2.3.4 Condition of spent fuel pool	2-46
2.4 Course of accident at Unit 3	2-57
2.4.1 From occurrence of earthquake to arrival of tsunami	2-57
2.4.2 From arrival of tsunami to hydrogen explosion of the reactor building	2-57
2.4.3 After hydrogen gas explosion in the R/B	2-61
2.4.4 Major events thereafter	2-61
2.4.5 Condition of spent fuel pool	2-62
2.5 Course of accident at Unit 4	2-72
2.6 Course of accident at Unit 5	2-77
2.7 Course of accident at Unit 6	2-81
2.8 Status of dose rate around power station	2-83
2.9 Evaluation of core conditions of Unit 1 to Unit 3 at time of accident	2-84
2.9.1 Evaluation of core conditions of Unit 1 at time of accident	2-84
2.9.2 Evaluation of core condition of Unit 2 at time of accident	2-85
2.9.3 Evaluation of core conditions of Unit 3 at time of accident	2-86

Chapter 3	Analysis of Causes of Accident Events and Extraction of Problems	3-1
3.1	Flow of accident events	3-1
3.2	Extraction of subject from accident event progress	3-4
3.2.1	Cause analysis from accident event progress (event tree)	3-4
3.3	Arrangement of problems confirmed from functional viewpoint	3-16
3.3.1	Causal analysis of the accident in Units 1 to 3 and management of issues	3-16
3.3.1.1	Problems by function	3-23
3.3.1.2	Problems related to common factors and failures	3-30
3.4	Causal analysis of the accident at Unit 4 and management of issues	3-32
3.5	Management of events at Units 5 and 6	3-35
3.6	Comparison of course of events at Fukushima Daiichi Nuclear Power Station with other stations	3-39
3.7	Causal analysis	3-43
Chapter 4	Lessons Learned and Measures to Take	4-1
4.1	Countermeasures against natural hazards	4-1
4.2	Securing power supply	4-1
4.3	Measures against loss of heat sink systems	4-2
4.4	Measures against hydrogen leakage	4-3
4.5	Preparation for emergencies (training and drills)	4-3
4.6	Countermeasures against earthquakes and tsunamis (example measures)	4-4
4.6.1	Assumption of earthquake and tsunami strength	4-4
4.6.2	Protection of the site from tsunami	4-5
4.6.3	Protection of buildings	4-5
4.7	Preparation for power supply (example measures)	4-7
4.7.1	SBO and loss of DC power supplies	4-7
4.8	Examples of measures addressing heat sink loss	4-9
4.8.1	Water injection in reactors	4-9
4.8.2	Loss of seawater cooling	4-10
4.8.3	Containment vent	4-11
4.9	Hydrogen measures	4-13
4.10	Emergency preparedness (especially training)	4-14
4.10.1	Training	4-14
4.10.2	Air conditioning and shield at Main Control Room	4-15
4.10.3	Measurement during accidents	4-15
4.10.4	Emergency operation facility	4-17
4.10.5	Radiation control and working control	4-18
4.10.6	Organization and command or order	4-20
4.10.7	Communication	4-20
4.10.8	Environmental monitoring	4-21
4.10.9	Preparing disaster countermeasures (heavy equipment and rescue), emergency cooperative framework	4-23
4.11	Security of integrity of spent fuel	4-24
4.12	Summary of countermeasures	4-25
Chapter 5	Timeline of Accident to the Present	5-1
Chapter 6	Conclusion	6-1

Appendix 1	Countermeasure implementation situation at present nuclear power stations	app-1-1
Appendix 2	Comments from members of the technical analysis subcommittee, Atomic Energy Society and responses	app-2-1
Appendix 3	Comparison of the Development of the Accident at the Fukushima Daiichi Nuclear Power Station and at Other Stations (Detailed Version)	app-3-1
Appendix 4	Agenda for Future Review	app-4-1
Appendix 5	Comparison with Government Report and NRC Task Team Report	app-5-1
Appendix 6	MARK-I Containment	app-6-1
Reference 1	Station Overview	ref-1-1

Chapter 1 Purpose

The accident at the Fukushima Daiichi Nuclear Power Station that happened due to the major earthquake that took place on March 11, 2011, made us realize once again, how severe the consequences can be in the case of an accident at a nuclear power plant. It also destroyed the public's trust in nuclear technology, which had been built up till now by that industry. It is very important that we seriously consider why the nuclear power industry could not prevent such an accident and ensure that nuclear power plants are even safer so that serious accidents can be prevented.

Hence, we conducted an investigation by setting up the Fukushima Daiichi Nuclear Power Station Accident Investigation Committee in the Japan Nuclear Technology Institute. Our aim was to summarize the necessary countermeasures by gathering the lessons learned from the Fukushima Daiichi Nuclear Power Station accident and focusing all the efforts of the Japan nuclear power industry.

The investigation committee is formed of the Japan Nuclear Technology Institute, Tokyo Electric Power Corporation and manufacturers, and has proposed various necessary countermeasures by drawing lessons from this disaster and keeping a focus on the analysis of reasons. It has done so based on the information related to plant design and information accumulated from its experience operating power plants.

Presently, work to recover from the accident is going on in Fukushima Daiichi Nuclear Power Station, but at the same time, it is also necessary to execute countermeasures so as to ensure even more safety in the nuclear power plants functioning within the country. Likewise, the adequate countermeasures should be taken for the halted power plants.

The scope of the investigation covers from the occurrence of the earthquake to the tsunami and up to the release of radioactive material. It was based on all the information related to the Fukushima Daiichi Nuclear Power Station accident published by Tokyo Electric Power Corporation. The main purpose of the investigation was to analyze the reasons for the accident and investigate countermeasures with a view to ensuring policies to prevent accidents due to the tsunami, preventing such accident from escalating, and reducing their effects.

Based on the facts related to the development of the accident the analysis of the main cause for widespread of the accident was analyzed according to the event tree and topics were picked up. Moreover, the reason why the safety system could not work was organized in matrix format from the [stop], [cool] function screens ensuring safety and topics were picked up in such a way that no topic is missed.

Based on all these topics, lessons were extracted and a variety of concrete examples of countermeasures summarized.

Further, we are continuing to make investigations whenever we find new topics and continue to design countermeasures by giving importance to issues that should be tackled by the industrial world. We also decided that in the case of issues which need to be analyzed with the government or self-governing bodies, such as Bousai, we will continue investigations regarding how to deal with them as an enterprise.

Hereafter, we will keep proposing additional countermeasures so as to improve safety after conducting investigations and revising this report; if we identify new facts and find important topics.

Chapter 2 Fukushima Daiichi Nuclear Power Station Accident Development

2.1 Complete overview of Fukushima Daiichi Nuclear Power Station and accident

2.1.1 Overview of Fukushima Daiichi Nuclear Power Station

Fukushima Daiichi is located in the north-east of Japan (latitude 37° North, longitude 141° East), It is located in Okuma and Futaba City of Fukushima Prefecture, which is approximately 225 km to the north of Tokyo and is facing the Pacific Ocean. (Population of Okuma city: approximately 11,500, Futaba City: approximately 6,900.)



The site area of the power plant is approximately 3,500,000 m², in a semicircular shape stretching 1.5 km east-west and 3 km north-south. It is 35 m above sea level and is leveled at a height of approximately 10 to 13 m facing a flat beach and consists of 6 boiling water reactors (hereafter called BWR).

The arrangement of power plant premises is as shown below, units 1 to 4 are located in Okuma City and Unit 5 and Unit 6 are in Futaba City. The main office is located on elevated ground.

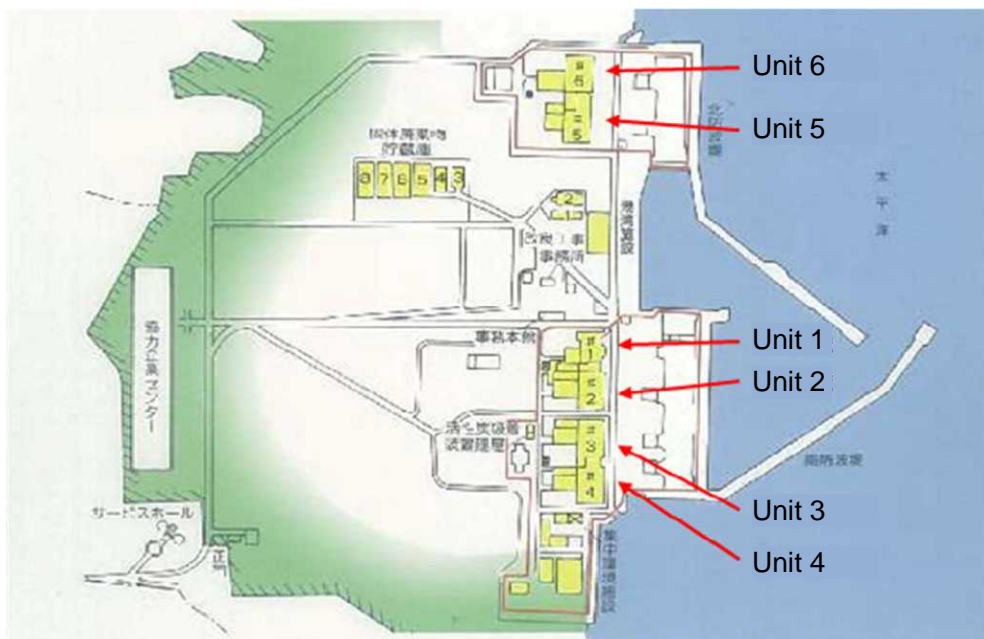

Each unit of the power plant units started operating in 1970 and the total power output is 4,696 MW. The salient features of each unit are described below.

Unit	Electric power (MW)	Operation start day	Reactor model	Container model	Reactor supplier
1	460	March 26, 1971	BWR-3	Mark I	GE
2	784	July 18, 1974	BWR-4	Mark I	GE, Toshiba
3	784	March 27, 1976	BWR-4	Mark I	Toshiba
4	784	October 12, 1978	BWR-4	Mark I	Hitachi
5	784	April 18, 1978	BWR-4	Mark I	Toshiba
6	1100	October 24, 1979	BWR-5	Mark II	GE, Toshiba

2.1.2 Overview of Great East Japan Earthquake and Tsunami

The earthquake took place at around 2:46 p.m. on March 11, 2011 with the epicenter located approximately 130 km to the east-south-east of Sanriku, Oshika Peninsula (latitude 38.1°N, longitude 142.9 °N)

- Scale: Moment Magnitude Mw 9.0
- Depth of epicenter: 24 km
- Aftershocks: 6 with a magnitude of more than M7.0, 93 with a magnitude of more than M6.0 (announcement on September 8 by meteorological agency).
- Maximum slippage: Approximately 30 m
- Rupture: Length approximately 450 km, width approximately 150 km
- Time of continuous destruction: Approximately 170 seconds

Earthquake of the coast of Sanriku at around 2.46 pm on March 11, 2011
Earthquake Distribution Diagram

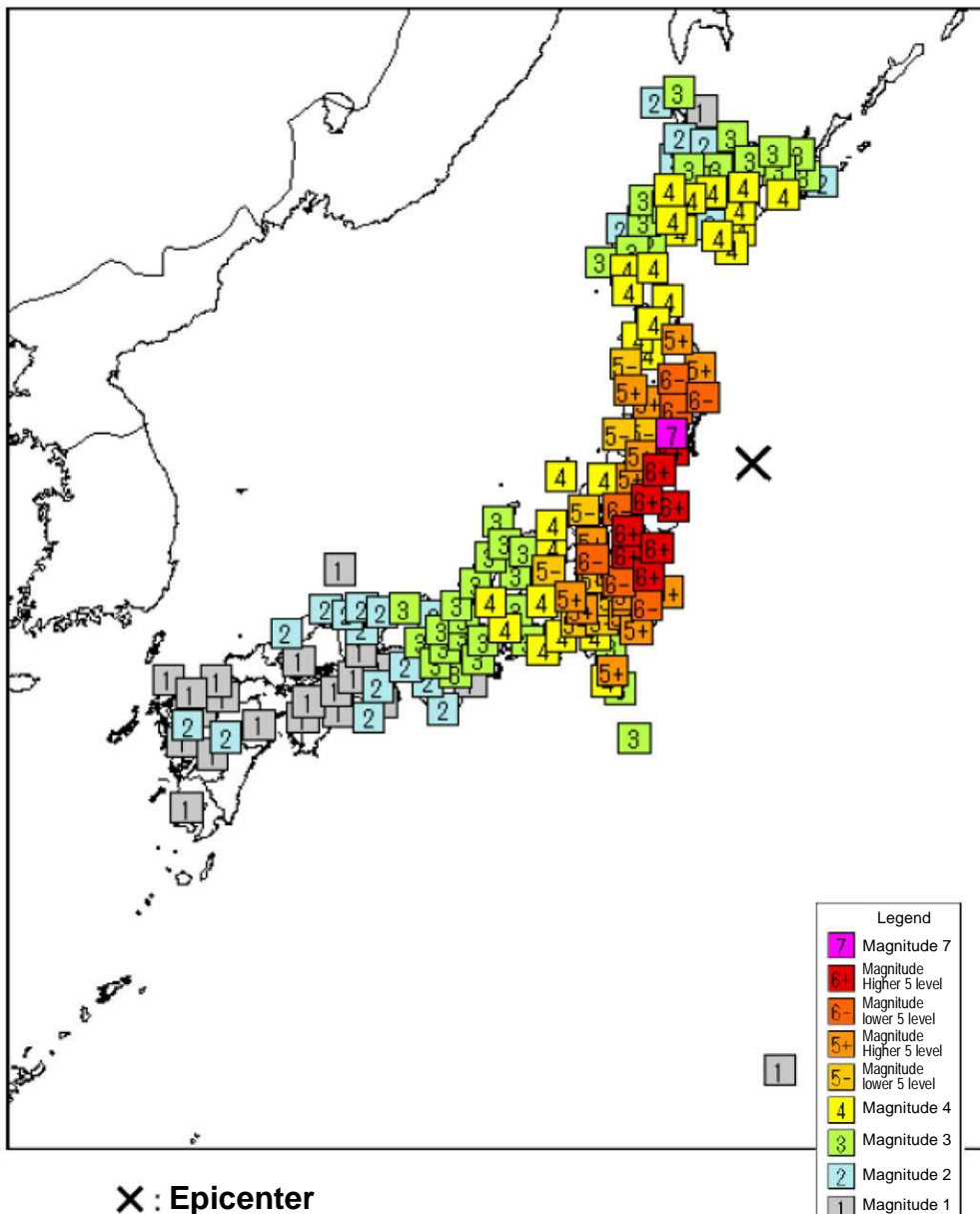

X : Epicenter

Source: Meteorological Agency

(About Sanriku earthquake which occurred at 14:46 on March 11, 2011)

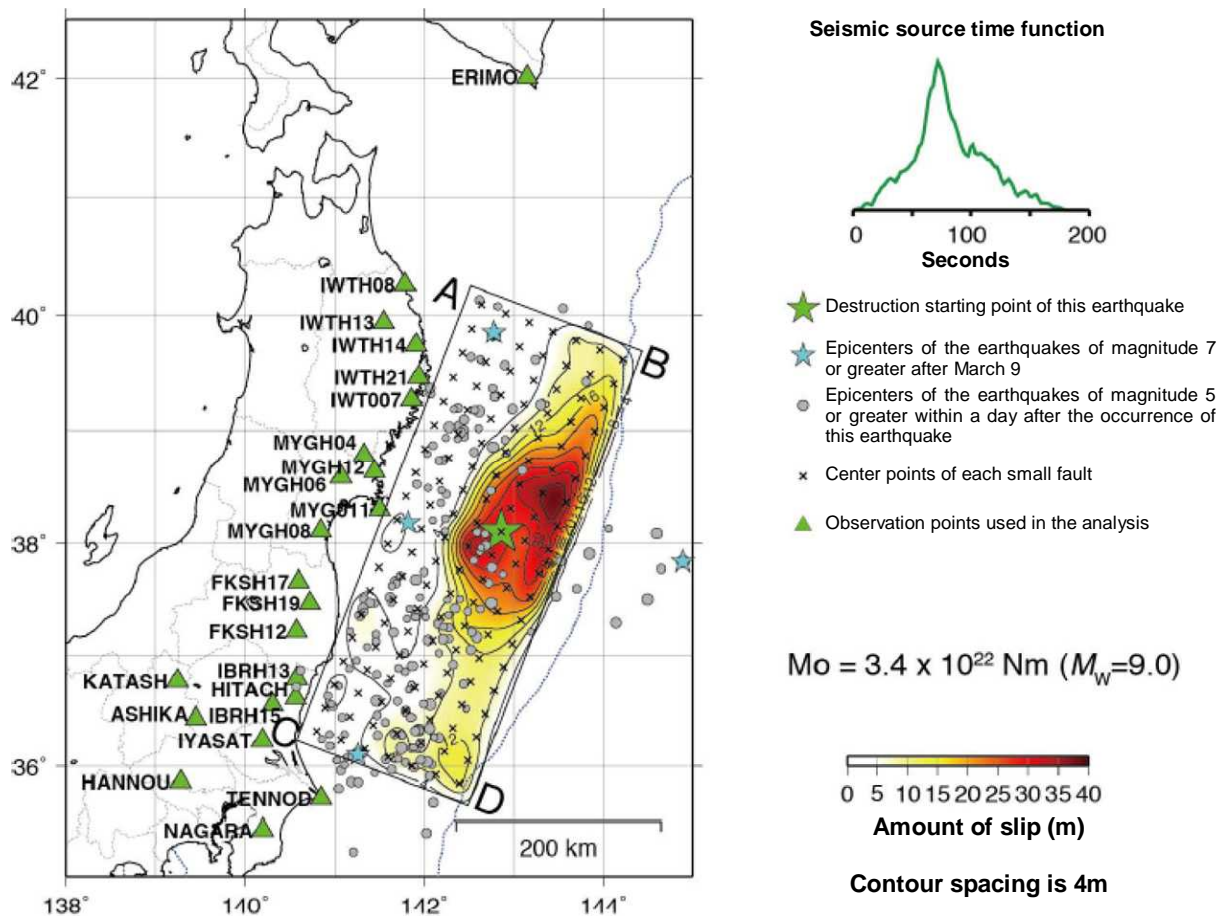

Source: Meteorological Agency (March 2011, earthquake, volcano monthly report)

It is presumed that the tsunami occurred when the sea floor rose roughly above the epicenter by approximately 3 m. The maximum height was about 35 m to the north of Miyako City. Also, the height of flood to the north of Miyako City has exceeded 25 m. The flood area has become 58 km² in Iwate Prefecture, 327 km² in Miyagi Prefecture, 112 km² in Fukushima Prefecture and 23 km² in Ibaraki Prefecture.

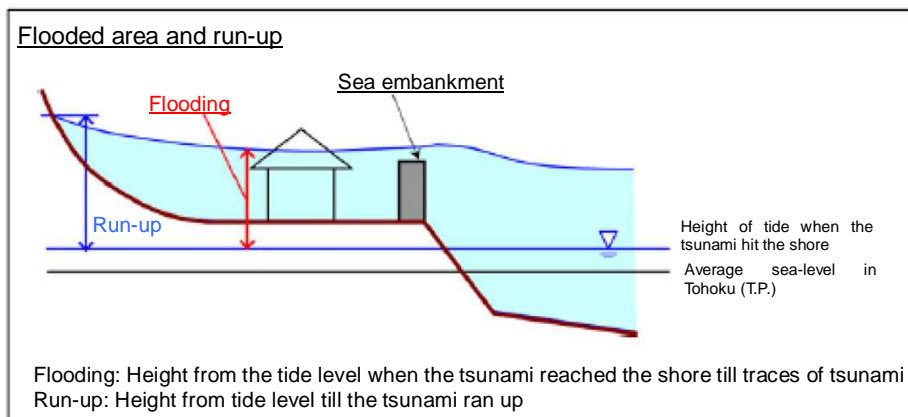
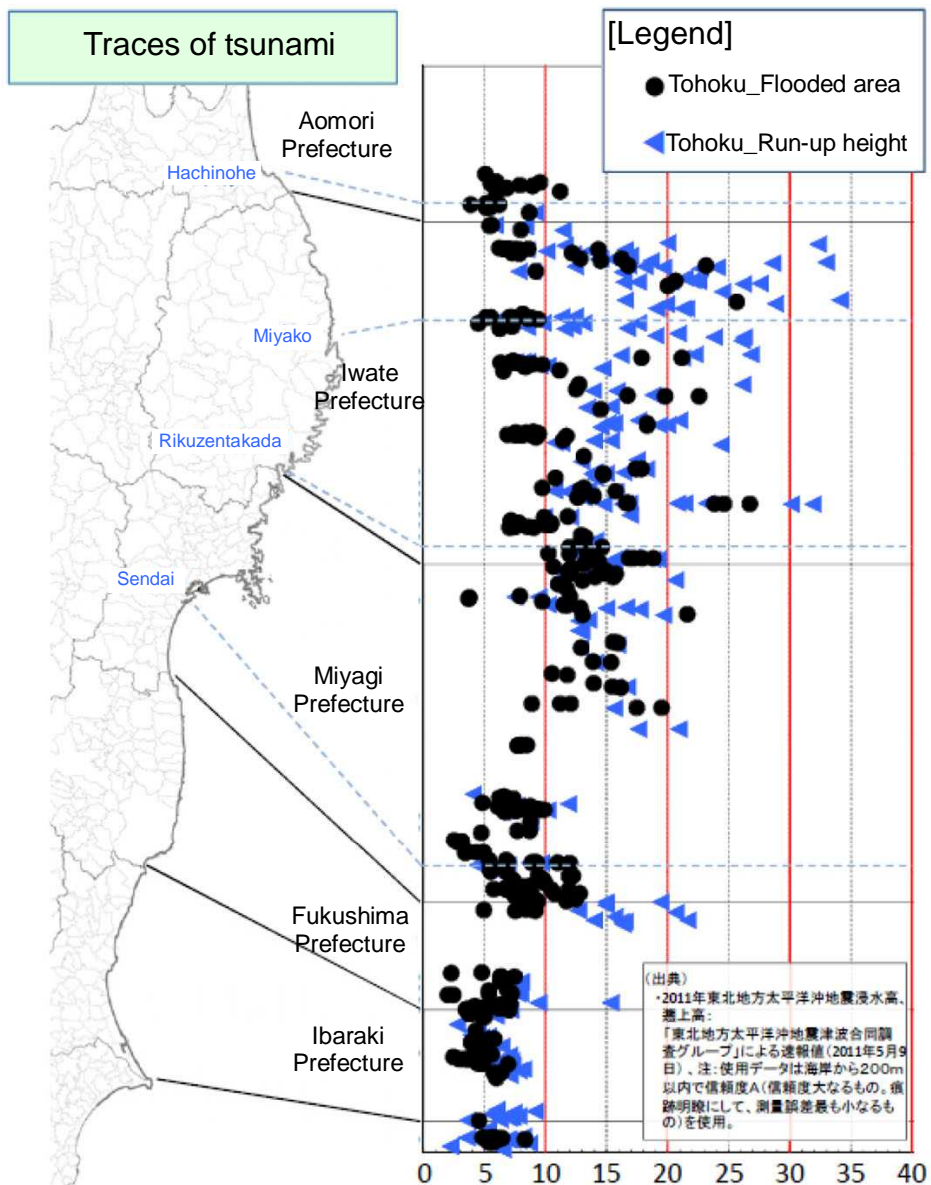

Source: Excerpts from First Special Investigation Committee Meeting related to earthquake and tsunami study of Great East Japan Earthquake

As of September 26, the damage due to the earthquake and tsunami is as serious as 15,811 deaths, with 4,305 people missing, and complete destruction of 117,542 buildings and partial destruction of 177,192 buildings.

2.1.3 Overview of accident due to Great East Japan Earthquake

When the Great East Japan Earthquake occurred on March 11, Units 1, 2 and 3 of the Fukushima Daiichi Nuclear Power Station were in operation, whereas units 4, 5 and 6 were not in operation; the spent fuel pool in Unit 4 was in a used up condition (hereafter termed as SFP) as its shroud was being replaced.

When the earthquake of magnitude 9 occurred at 14:46 on March 11, Units 1, 2 and 3, which were in operation, automatically stopped due to a [Peak Earthquake Acceleration] signal. The outside electric power supply was completely lost as the outside electric power supply facilities, circuit breakers, cables, steel power lines and such like got damaged or were destroyed due to this earthquake. Hence, all the units except Unit 4, which was undergoing a periodic inspection, automatically started to use a diesel engine generator (hereafter called “emergency use diesel generator”) and the cooling functionality of the nuclear reactor as well as SFP was maintained.

After that, all the emergency diesel generators, except the emergency DG 1 of the air cooling system of Unit 6, stopped operating as the emergency diesel generators, seawater pump and power supply equipment were all submerged in water due to a large tsunami. AC power supply to Units 1 to 5 was completely lost.

This large tsunami swept away heavy machines, tanks and such like in the flood water within the power plant, and a great deal of rubble was scattered on the roads; moreover, it became completely dark inside the premises, almost all the means of communication had stopped. In this situation, two workers who were conducting post-earthquake investigations in the turbine building (hereafter called “T/B”) of Unit 4, were lost and later confirmed to be dead.

In Fukushima Daiichi Nuclear Power Station, at 15:42 on March 11, the Station concluded that the situation corresponded to a particular phenomenon (complete loss of AC power supply) as per Article 10 of the Special Law of Emergency Preparedness for Nuclear Disaster (hereafter called “Special Law for Nuclear Emergency”) and the Station announce it to the national and local government bodies. Also, the power supply to measurement displays was also lost and hence it was not possible to determine the water level of the nuclear reactor or the flood conditions. Hence, the Station concluded that the situation corresponded to a particular phenomenon in which emergency core cooling equipment cannot inject water and announced this to the national and local government bodies at 16:45.

The summary of how the accident spread for all units is mentioned below.

After automatic shutdown of Unit 1, on March 11 at 14:47, the main steam isolation valve (MSIV) (hereafter called “MSIV”) stopped due to a loss of external power supply, the pressure of reactor pressure vessel (hereafter called “RPV”) rose, the emergency condenser (hereafter called “IC”) automatically started at 14:52. As per the operation manual, workers performed a control operation by repeating the manual operations (isolation valve open-close) of IC, so that the rate of decrease in RPV temperature did not increase above 55°C/h.

After this, all the AC power was lost and simultaneously the DC power was also lost due to a large tsunami that came at 15:37 on March 11. Hence, it was not possible to pump out the water in the nuclear reactor or confirm the status of the parameters. Hence, workers started preparing to use alternative water pumping methods. When the water level was restored at 21:19 on March 11, due to the

temporary recovery of the electricity supply, it was confirmed that the water level was above the available fuel level (hereafter called "TAF"). The radiation level of T/B rose around 11:00 on March 11. At 0:06 on March 12, workers were instructed to prepare for PCV venting by the nuclear power plant manager, as there was a possibility that the PCV pressure had exceeded the maximum allowed pressure. At around 5:46 on March 12, alternative pumping of water started. At 7:11 on March 12, the prime minister visited the power plant to make observations and returned to Tokyo at 8:04. The evacuation of residents of Okuma City (Kumachi-ku) was confirmed at 9:03 on March 12. At around 9:15, 25% of the monitor valve (hereafter called "MO valve"), which is one of the two valves in series in the PCV vent line, opened manually; after that we went towards the premises to open the other air operation valve (hereafter called "AO valve"), but it was not possible to do so due to high level of radiation. When the valves were opened from the main control room (hereafter called "MCR"), it could not produce a sufficient result and hence, a temporary air compressor was set up and the AO valve was opened. Thus, the PCV pressure reduced at around 14:30. After this, at around 15:36 on March 12, there was a hydrogen explosion (hereafter called "hydrogen explosion") in the upper part of the nuclear reactor building; the roof and outer walls were damaged. The injection of seawater into the nuclear reactor started at around 19:04 on March 12.

In the case of Unit 2, after it automatically shut down at 14:47 on March 11, MSIV stopped and the RPV pressure rose due to a loss of external power supply, but the pressure was controlled due to main steam safety relief valve (hereafter called "SRV"). The nuclear reactor water level control was done by the reactor core isolation cooling system (hereafter called "RCIC") and after repeated operations of manual start by the workers and auto -stop according to [nuclear reactor water level], once again RCIC was started manually at 15:39 on March 11. Immediately after this, at 15:41, the AC power was lost completely and at the same time, the DC power was also lost; hence, it was not possible to confirm the status of the water injection into the nuclear reactor or that of the parameters.. When the nuclear reactor water level was restored due to the temporary recovery of a power supply at 21:50, it was confirmed that the nuclear reactor water level had been maintained. The workers confirmed that the RCIC was functional when they checked the field instrument at around 2:00 on March 12.

The power supply recovery operation of the alternate water injection system was continued, but it was interrupted as the power supply cables were damaged due to the hydrogen explosion that occurred in Unit 1 at 15:36 on March 12. Moreover, the workers continued to prepare to inject seawater and they had laid a hose or fire engine, but it was damaged due to the hydrogen explosion in Unit 3 which occurred at 11:01 on March 14 and hence became unusable. Moreover, preparation work for a PCV vent, which was also in progress at the same time, was significantly affected by the explosion.

On March 14, at around 13:25, the Station concluded that the situation in the nuclear reactor was as per Article 15 of the Act on Special Law of Emergency Preparedness for Nuclear Disaster, due to a possibility that the RCIC had stopped due to the reduced water level. When radiation caused by the explosion in Unit 3 was spreading, the injection of seawater and preparation work for a PCV vent were started again. On March 14, at around 18:00, the pressure in the nuclear reactor began to be reduced due to SRV and at around 19:54 on March 14, the seawater injection started with a fire engine. The dry well (hereafter

called "D/W") pressure exceeded the maximum operating pressure at 22:50 on March 14. At around 6:00 on March 15, there was a sound of an impact and almost at the same time, the pressure inside the pressure control room (hereafter called "S/C") fell below 0 MPa [abs]. The pressure of D/W also fell below 155 KPa [abs] at 11:25 on March 15.

After automatic shutdown of Unit 3 at 14:48 on March 11, MSIV stopped due to the loss of external power supply, the RPV pressure rose but the pressure was controlled by the SRV. At 15:05 on March 11, the RCIC was started manually to control the nuclear reactor water level and the RCIC was stopped after that, corresponding to an indication [reactor high water level] which was due to a rise in the nuclear reactor water level at 15:25.

After that, the AC power supply was lost completely at 15:38 on March 11, due to a large tsunami. However, the RCIC and high pressure injection system (hereafter called "HPCI") operation was possible as the flood was avoided due to the DC power supply. The operation was continued by restarting the RCIC at 16:03 on March 11, but it automatically stopped at 11:36 on March 12. This resulted in a lower water level, HPCI started automatically at 12:35, corresponding to [reactor low water level] indication and recovered the previous water level. However, at 2:42 on March 13, the HPCI also stopped and RCIC also could not be restarted. Due to this, the Station concluded at 5:10 at March 13 that the situation corresponded to Article 15 of the Act on Special Law of Emergency Preparedness for Nuclear Disaster. At 9:08 on March 13, the SRV was manually started using an automobile battery, the nuclear reactor pressure was lowered and injection of fresh water containing acid started at around 9:25. After this, as the fresh water supply was exhausted, the workers switched to seawater at 13:12 on March 13.

On one side, the work to prepare the PCV vent line was also in progress at the same time, and both the valves (MO valve and AO valve) of the PCV vent line were opened at 8:41 on March 13. At 9:24 on March 13, the workers noticed that the pressure of the D/W had fallen. After this, the AO valve of the vent line closed due to a reduction in the pressure of the compressed gas cylinder, hence this valve was opened by replacing the cylinder and setting up a temporary compressor. At around 11:01 on March 14, an explosion that was assumed to be a hydrogen explosion occurred at the upper part of the nuclear reactor building and the roof and walls were damaged.

The injection of seawater was temporarily interrupted as the fire engine and hose which were being used for the injection of seawater was damaged by this impact. After this, the hose was drawn out from the pier and the injection of seawater was started again by the fire engine at around 16:30 on March 14.

Unit 4 was undergoing a periodic inspection and all fuel assemblies had been removed from the reactor to the spent fuel pool due to the shroud replacing work. Therefore, fuel with relatively high decay heat for one full core was stored in the SFP. A total of 1,535 pieces of spent fuel assemblies were stored there, which amounted to 97% of its storage capacity of 1,590 pieces. Due to the loss of the external power supply and subsequent loss of AC power supply, the electric motor operated pump and seawater system pump became nonfunctional and the cooling function of the SFP and make-up water function was lost. At 4:08 on March 14, the SFP water temperature rose to 84°C. At around 6:00 on March 15, an explosion that was assumed to be a hydrogen explosion occurred in the reactor building, and it was confirmed that the upper part of the building

collapsed. Furthermore, at 9:38 on March 15, a fire was identified in the northwest part of the third floor of the reactor building.

On March 16, when an SFP inspection was done by the Self-Defense Forces helicopter, they stated that the fuel was not exposed by observing the water surface. Water was injected in the SFP by the Self-Defense Forces on March 20 and by a U.S. armed forces high-pressure water truck on March 21. Moreover, the injection of water was carried out by a concrete pump motor after March 22.

The cause of the hydrogen explosion which occurred in Unit 4 was not clearly identified initially. Later, it was assumed that it must have been because the fuel in the SFP was exposed because of the low water level in the SFP due to evaporation and hence, the water from the nuclear reactor side flowed into the SFP through the pool gateway. Moreover, it could be considered after analyzing of nuclides from the water that there was no damage to the fuel rods and hence, it was thought that the main cause of the hydrogen explosion was not the fuel within the SFP, but one possible reason was the hydrogen gas, which was released by the PCV vent line of Unit 3 and flowed through the exhaust duct.

Unit 5 was undergoing a periodic inspection, and RPV pressure leakage tests were being conducted with fuel loaded in the reactor. There was enough water in the RPV and all the control rods were inserted.

Due to the loss of external power supply and large tsunami after that, the AC power supply was also completely lost, but the flood water was prevented from entering the building because of the DC power supply and the plant could be used. The nuclear reactor pressure rose due to decay heat, but because the SRV (safety valve function) was opened and closed from around 1:40 on March 12, the pressure dropped below the maximum operating pressure. At 6:06 on March 12, the upper vent valve of the RPV was manually opened from the control room and the pressure was lowered below the atmospheric pressure level, in order to carry out an alternative injection of water in the nuclear reactor. At 20:54 on March 13, a temporary cable was laid from Unit 6 to the condense water makeup system (hereafter called "MUWC") and the MUWC pump was started manually. Due to the effect of decay heat, the pressure within the nuclear reactor rose once again. To combat this, the control was recovered for the SRV system, which had been made nonfunctional in order to perform the Leak and Hydrostatic test, and after 5:00 on March 14, the pressure of RPV was lowered intermittently. After 4:30 on March 14, the alternative water injection to the nuclear reactor was started by MUWC and after that the water level of the nuclear reactor was checked by performing water injection intermittently. Moreover, the supply of water to the SFP was started at 9:27. At 1:55 on March 19, a temporary RHR seawater pump was started and after that, the RHR pump was manually started at around 5:00 on March 19, and SFP cooling was started. At 12:25 on March 20, the cooling of nuclear reactor was started by changing the operation mode of the RHR system and it was stopped at 14:30 on March 20.

Unit 6 was undergoing a periodic inspection and the nuclear reactor and was in cold shutdown condition (all control rods (CR) were in an inserted state) with the fuel being loaded.

Due to the loss of external power supply and subsequent large tsunami, two emergency DGs (seawater type) halted and the remaining one emergency DG (air cooled type) could supply electricity via an emergency generating line because the flood water did not enter and the power supply was also available.

At 13:20 on March 13, alternative injection of water to the nuclear reactor was started by manually starting the MUWC pump at 13:01. After that, the injection of water to the nuclear reactor was continued intermittently. Then, water to the SFP was continuously supplied from 14:13 on March 14.

In response to the rise in pressure of the nuclear reactor due to the effect of decay heat, SRV was manually opened from the control room and the reactor pressure was lowered continuously . At 19:07 on March 18, the Station confirmed that the emergency DG seawater pump (6A), which had been flooded by the tsunami, was in good condition and hence the same seawater pump was started and at the emergency DG (6A) which had stopped at 4:22, was started. At 21:26 on March 19, the temporary RHR seawater pump was started and at 22:14 on March 19, the RHR pump was started and the SFP cooling was started. At 18:48 on March 20, the operation mode of RHR system was switched and cooling of nuclear reactor was started and it was stopped at 19:27 on March 20.

2.1.4 Impact of earthquake

An earthquake occurred with its seismic center off the coast of Miyagi Prefecture at 14:46 on March 11, 2011.

The earthquake had an earthquake focal depth of 24 km, moment magnitude of 9.0, rupture length of 450 km, and rupture width of about 150 km (all estimated). It is thought the earthquake occurred because the end of the plate was destroyed due to the accumulation of strain at the plate boundary. It is thought the rupture length became long because of multiple seismic centers became linked.

As shown in Table 2.1-1, the maximum acceleration value obtained on the reactor building's base mat (lowest ground floor) from this earthquake partially exceeded the maximum response acceleration value with respect to the basic design earthquake ground motion S_s .

Figure 2.1-1 shows the acceleration time history waveform and response spectrum observed on the reactor building's base mat for Unit 2, as an example. In this observed record, the acceleration exceeded the response spectrum by the basic design earthquake ground motion S_s in some periodic bands but it was almost in the same range.

Before the arrival of the tsunami, the functions of the engineered safety features, such as the emergency core cooling system (hereinafter referred to as "ECCS") (including the seawater system), were sound as the seawater system, IC, RCIC, and such like were operated by receiving a power supply from the emergency DG. It was confirmed that of the nonessential equipment, the Make-Up Water Condensate (MUWC), diesel driven fire pumps of Units 1 and 3 (hereinafter referred to as "D/D-FP"), and such like were operable even after the earthquake.

As shown in Figs. 2.1-3-1 to -3, the RPV pressure of Units 1 to 3 fluctuated, according to the operation of each component, before the tsunami arrived following the earthquake. No rapid drop in pressure and no continuation of its decreasing tendency, as observed when the piping of the reactor coolant pressure boundary fractures, were shown. In a similar way, although a rise in the temperature in the PCV due to the stop of air conditioning was shown in Fig. 2.1-4-1 to 2.1-4-3, the temperature rise was not large in every case and a saturation tendency was seen in the rise. Therefore, it is judged that the temperature rise occurred, but not resulting from the fracture of the piping. Although there has been an argument to see whether the piping had fractured due to the earthquake before the tsunami arrived, we think the piping of the reactor coolant pressure boundary was sound.

According to the government's instructions, TEPCO conducted seismic response analysis on the reactor buildings and components/piping important to seismic safety of Units 2 and 4 on June 17, and of Units 1 and 3 on July 28, based on the observed records. TEPCO concluded that all the components important to safety were able to maintain their safety functions at the time of the earthquake and immediately after the earthquake.

For the external power source before the earthquake occurrence, the Okuma No. 1 line and No. 2 line (275 kV) for Units 1 and 2, the Okuma No. 3 line and No. 4 line (275 kV) (note, however, that the switching equipment of the Okuma No. 3 line was under construction) for Units 3 and 4, and Yonomori No. 1 line and No. 2

line (66 kV) for Units 5 and 6 were being connected to the Shinfukushima substation. In addition, the TEPCO Genshiryoku line (66 kV) from Tohoku-Electric Power Company's Tomioka substation was being connected to Unit 1 as a spare line.

The earthquake damaged the breakers, and such like of the switchyards of Units 1 and 2 as well as the cable of TEPCO Genshiryoku line from Tohoku-Electric Power Company. For Units 3 and 4, the equipment for the No. 3 line and No. 4 line on the Shinfukushima substation side was damaged. For Units 5 and 6, one transmission tower connected to the switchyards collapsed. As a result, all the external power sources from Unit 1 through Unit 6 were lost.

Comparing the natural period (0.3 to 1 sec) of the steel tower with the earthquake ground motion's acceleration response spectrum (maximum response acceleration of a little over 2000 gal) and observing the collapse situation, it was judged that the steel tower did not collapse due to the earthquake ground motion but did so due to falling earth and sand.

Table 2.1-1 Maximum acceleration from basement of reactor buildings

Observation point (basement of reactor buildings)		Observed data			Maximum response acceleration against basic earthquake ground motion Ss (Gal)		
		Maximum response acceleration (Gal)			North-South Direction	East-West Direction	Vertical Direction
		North-South Direction	East-West Direction	Vertical Direction			
Fukushima Daiichi	Unit 1	460	447	258	487	489	412
	Unit 2	348	550	302	441	438	420
	Unit 3	322	507	231	449	441	429
	Unit 4	281	319	200	447	445	422
	Unit 5	311	548	256	452	452	427
	Unit 6	298	444	244	445	448	415

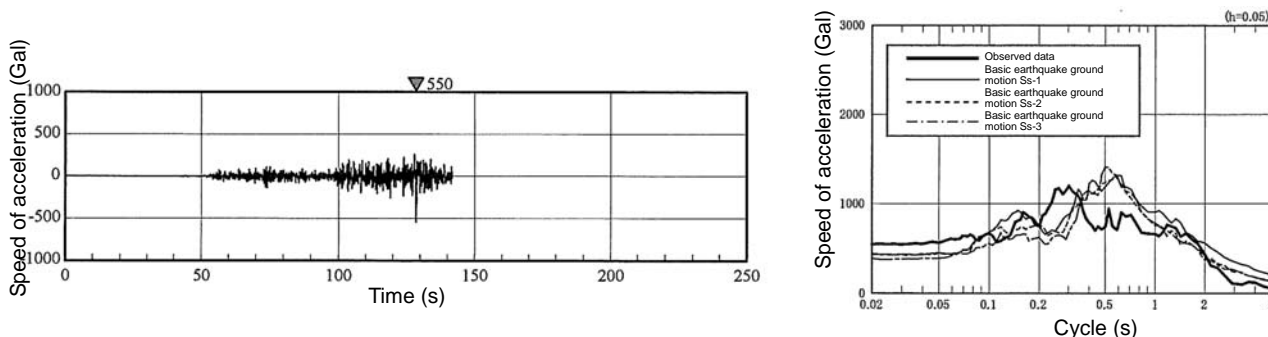

(Note: The recording equipment was interrupted due to the earthquake)

Figure 2.1-1 Ripple figure of instant acceleration history of reactor building and response spectrum (east-west direction)

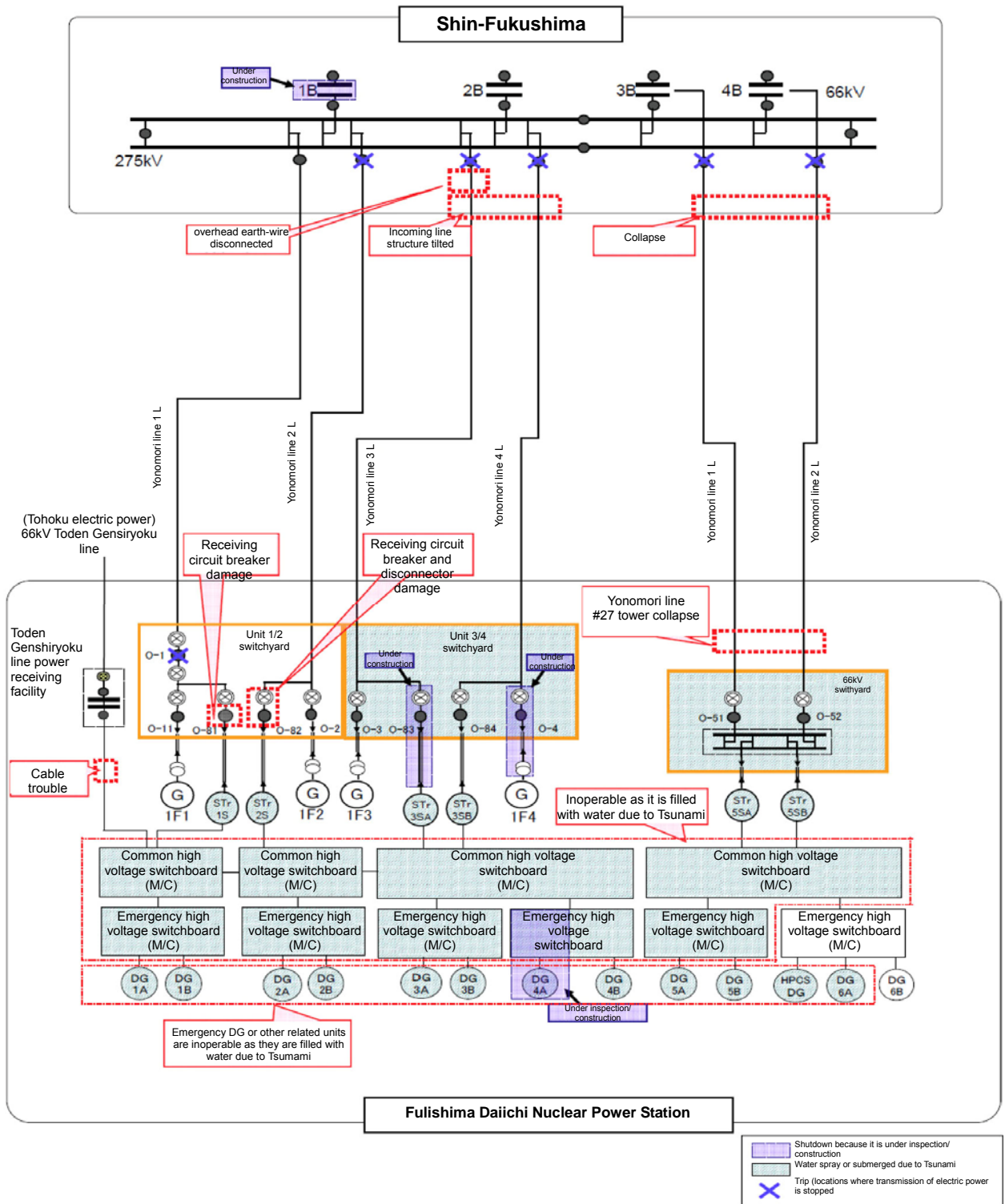

Figure 2.1-2 Outline figure of external power supply control system (after earthquake, before tsunami)

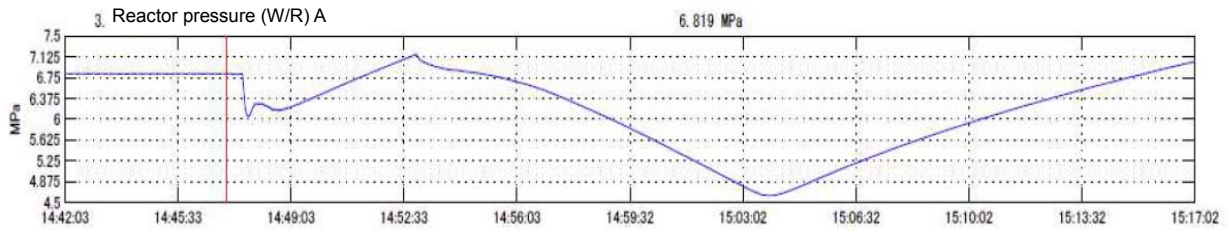
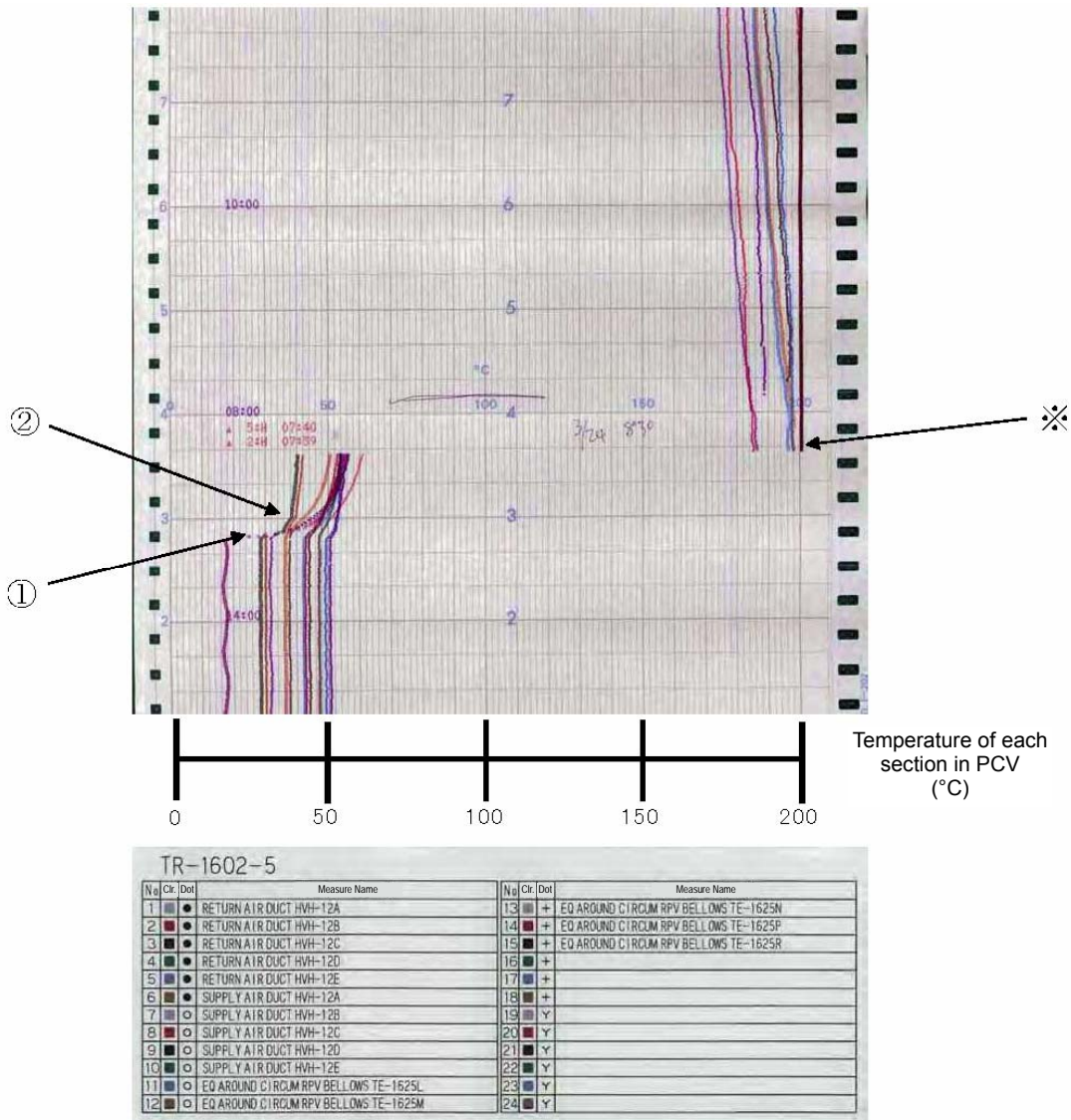

Fig. 2.1-3-1 Unit 1's reactor pressure (trend data by transient recorder)



- (1) 14:46 Scram due to the earthquake
 (2) Temperature rise of the PCV because the containment air handling system stopped due to loss of power (no excessive rise in temperature attributable to piping rupture, and such like was observed).
 * After 15:30, the recorder power was lost due to arrival of the tsunami and the recorder once stopped. Recording was resumed after the recorder power was restored on March

Fig. 2.1-4-1 Temperature of each section in Unit 1's primary containment vessel

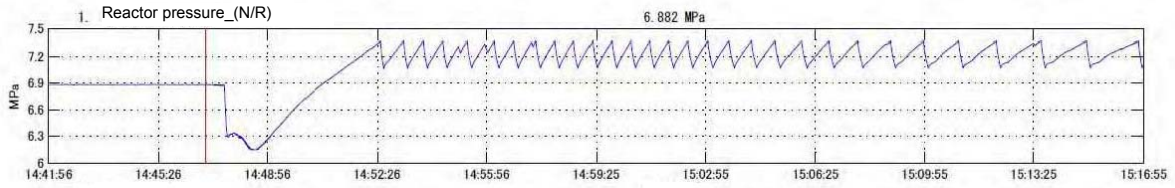
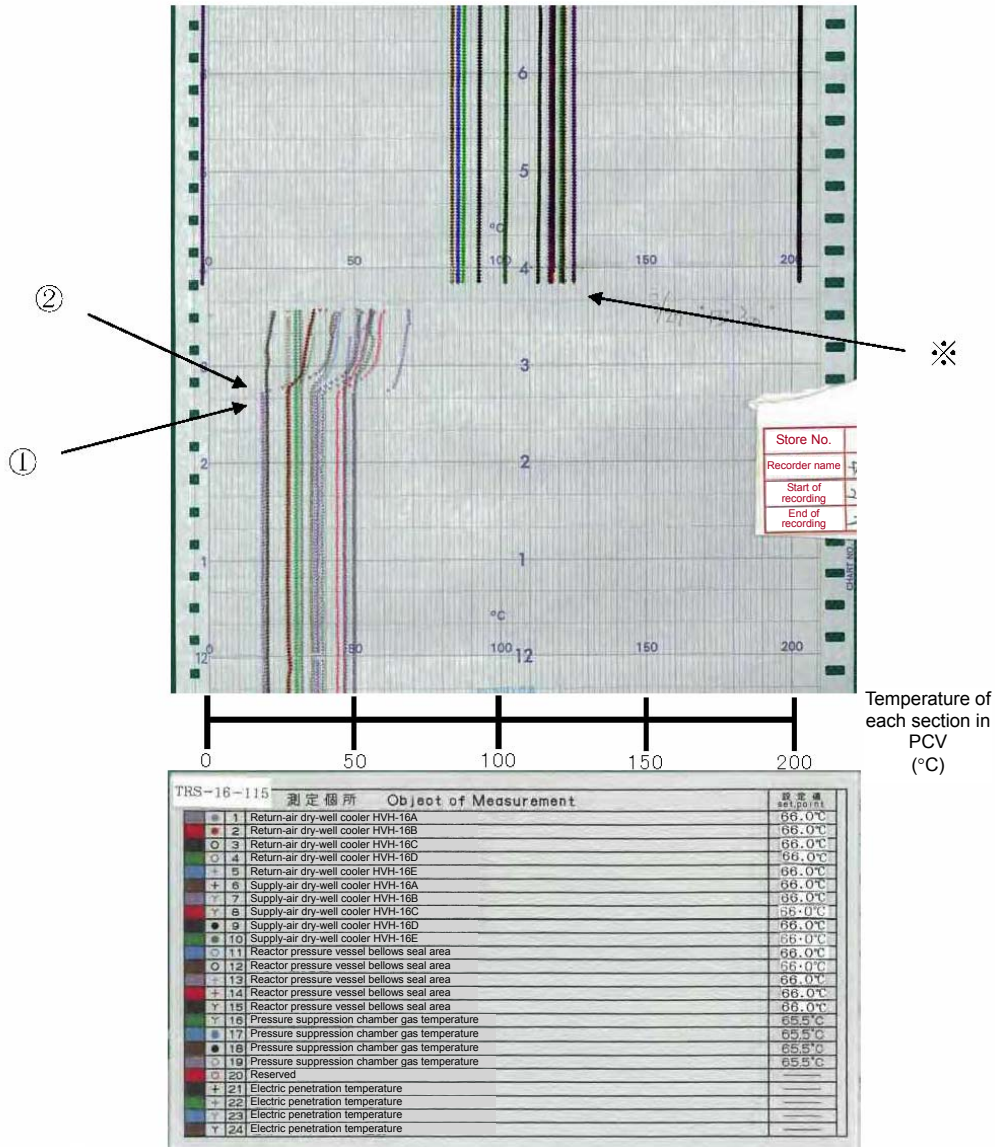

Fig. 2.1-3-2 Unit 2's reactor pressure (trend data by transient recorder)



(1) 14:47 Scram due to the earthquake
 (2) Temperature rise of the PCV because the containment air handling system stopped due to loss of power (no excessive rise in temperature attributable to piping rupture, and such like was observed).
 *It is assumed that the tsunami arrived after 15:30. It is also assumed that an accurate indication was not shown due to the effect of the tsunami. However, the recorder continued recording for a while after that because there was a DC power supply.

Fig. 2.1-4-2 Temperature of each section in Unit 2's primary containment vessel

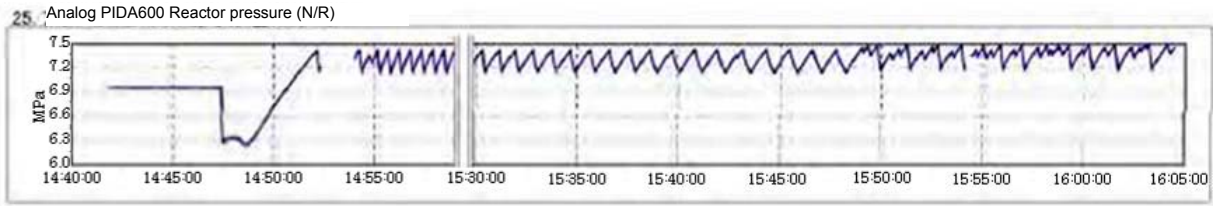
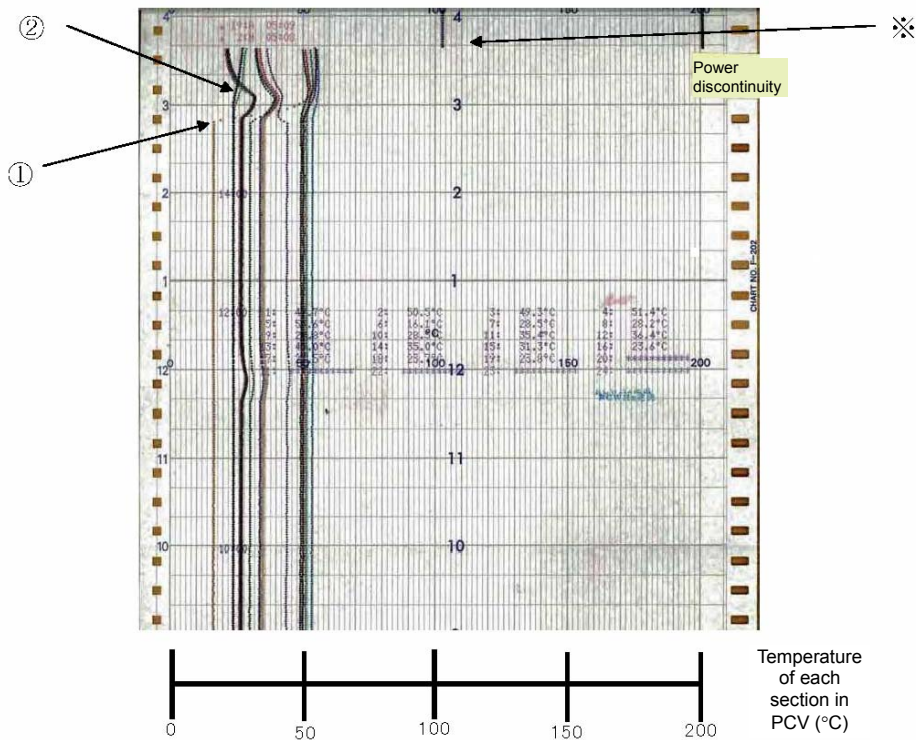

Fig. 2.1-3-3 Unit 3's reactor pressure (trend data by transient recorder)



TRC No.	Clr. Dot	Imp. Instrument No.	Imp. Instrument Measuring Point	Switch Set Value	Imp. No.	Clr. Dot	Imp. Instrument No.	Imp. Instrument Measuring Point	Switch Set Value
1	■	TE-16-114A	Containment air handling system return air temperature	65.6°C	13	■	TE-16-114I	Reactor bellows seal section temperature	65.6°C
2	■	TE-16-114B	Containment air handling system return air temperature	65.6°C	14	■	TE-16-114J	Reactor bellows seal section temperature	65.6°C
3	■	TE-16-114C	Containment air handling system return air temperature	65.6°C	15	■	TE-16-114K	Reactor bellows seal section temperature	65.6°C
4	■	TE-16-114D	Containment air handling system return air temperature	65.6°C	16	■	TE-16-114L	Pressure suppression chamber gas temperature	65.6°C
5	■	TE-16-114E	Containment air handling system return air temperature	65.6°C	17	■	TE-16-114M	Pressure suppression chamber gas temperature	65.6°C
6	■	TE-16-114F	Containment air handling system supply air temperature	65.6°C	18	■	TE-16-114N	Pressure suppression chamber gas temperature	65.6°C
7	■	TE-16-114G	Containment air handling system supply air temperature	65.6°C	19	■	TE-16-114O	Pressure suppression chamber gas temperature	65.6°C
8	○	TE-16-114H	Containment air handling system supply air temperature	65.6°C	20	■			
9	○	TE-16-114I	Containment air handling system supply air temperature	65.6°C	21	■			
10	○	TE-16-114J	Containment air handling system supply air temperature	65.6°C	22	■			
11	○	TE-16-114K	Reactor bellows seal section temperature	65.6°C	23	■			
12	○	TE-16-114L	Reactor bellows seal section temperature	65.6°C	24	■			

- (1) 14:47 Scram due to the earthquake
 (2) Temperature change in the containment vessel because the containment air handling system stopped due to loss of power and the power decreased due to a scram (no excessive rise in temperature attributable to piping rupture, and such like was observed).
 * After 15:30, it is considered that the recorder power was lost due to arrival of the tsunami and the recorder once stopped.

Fig. 2.1-4-3 Temperature of each section in Unit 3's primary containment vessel

2.1.5 Impact of tsunami

Due to the earthquake, at 15:27, the first tsunami came from the ocean which is on the front side of the reactor site and the second tsunami appeared at 15:35. Among these, the second was higher than the reactor height and almost the whole area of the main building of the site was flooded with water.

Based on the tsunami measurement methods of the Society of Construction Engineers, the design as revised in 2002 was for a height of tsunami of about O.P. +5.7 m (Fukushima Daiichi Unit 6). In contrast to this, the height of the tsunami which actually came was, O.P. approximately +11.5 to approximately +15.5 (depth of flood water approximately 1.5 to approximately 5.5.m) from the main building setup area (Fukushima Daiichi 1 to 4 unit side, site height O.P. +10 m) and O.P. approximately +13 to approximately +14.5 m (depth of flood water approximately below 1.5 m) from the main building setup area (Fukushima Daiichi 5 to 6 unit side, site height O.P. +13 m) (without including changes to the ground due to the earthquake).

The height of the tsunami was much larger than the tsunami height measurements that had been made so far, because of the activity of multiple territories which until now used to be thought of as single territory activity and hence a major earthquake of magnitude 9.0 occurred. The length of the dislocation was 400 km and width was 200 km, which was something that had never been seen before, and the slippage of the dislocation was extremely large at more than 20 m, which was something that had never been considered.

It is thought that the surrounding area of the main building, which is on a site of O.P. +10 m and O.P. +13 m, was almost flooded by the tsunami. However, no significant damage was confirmed to the construction of the outer wall or pillars of the main building. However, mainly considering the east side (sea side) of the T/B of Unit 1 to 4, parts of the door or shutter and such like installed at the entrance, were damaged by the tsunami. Parts of the entrance above the ground of the main building (entrance and exit of the main building and the entrance for moving the instruments (hatch), exhaust outlet (louver) or entrance connecting to the trench or ducts laid underground on the site (the penetration entrance for cables or plumbing) came in the path of the flood water inside the building and the flood water flowed through the passages or the stairs and flooded a large underground area.

A large number of emergency DGs and switchboards, which were installed in the basement (height 0 m to 5.8 m) of the reactor building or T/B, were damaged by the tsunami, all the units except Unit 6 lost the emergency electric supply. Out of the three emergency DGs in Unit 6, the DG installed in the reactor building did not stop and could receive an emergency electric power supply. The main DC busbar of units 1, 2, and 4 was under the flood water and that of 3, 5, 6 was not under the flood water. The extent of flooding of the emergency electric supply, emergency diesel power generation device and DC busbar and the impact is described in Table 2.1-2.

All the auxiliary cooling seawater pumps were also flooded by the tsunami. However, except the pumps which had been taken out for inspection, all the pumps were present at the installation location even after tsunami and the pump body was not washed away. Destruction of the crane used for equipment installation, damage to pumps or ancillary equipment when they collided with

flotsam and the mixing of seawater in electric motor bearing lubricating oil was identified.

It seems that the important safety instruments must also have been damaged due to the seawater flood within the reactor building, but because of constraints due to high radiation, investigation was not done. It was confirmed that during this the MUWC pumps of Units 1 to 4 were flooded and even after temporarily recovering the electricity, their functions could not be restored.

Table 2.1-2 Impact on in house electricity system due to flooded water of tsunami

	Units 1-3														
	Unit 1					Unit 2					Unit 3				
	Component	Installation site	Installation floor	Availability for use	Condition	Component	Installation site	Installation floor	Availability for use	Condition	Component	Installation site	Installation floor	Availability for use	Condition
Starting transformer	STr(1S)	Transformer yard	Above ground	Unclear	Immersed in water	STr(2S)	Transformer yard	Above ground	Unclear	Immersed in water Damage to the attachment such as insulator	STr(3SA)	Transformer yard	Above ground	Unclear	Cannot be checked (Note 1)
Cable	OF Cable (Switchyard - STr(1S))	-	Underground	Unclear	Partial appearance is good	OF Cable (Switchyard - STr(2S))	-	Underground	Unclear	Cannot be checked (Note 2)	OF Cable (Switchyard - STr(3SA))	-	Underground	-	Under repair
D/G	DG 1A	T/B	B1FL	x	Submerged	DG 2A	T/B	B1FL	x	Submerged	DG 3A	T/B	B1FL	x	Submerged
	DG 1B	T/B	B1FL	x	Submerged	DG 2B	Shared pool	1FL	x	M/C Submerged Cannot be used	DG 3B	T/B	B1FL	x	Submerged
Emergency high voltage switchboard (M/C)	M/C 1C	T/B	1FL	x	Immersed in water	M/C 2C	T/B	B1FL	x	Submerged	M/C 3C	T/B	B1FL	x	Submerged
	M/C 1D	T/B	1FL	x	Immersed in water	M/C 2D	T/B	B1FL	x	Submerged	M/C 3D	T/B	B1FL	x	Submerged
	-	-	-	-	-	M/C 2E	Shared pool	B1FL	x	Submerged	-	-	-	-	-
Regular high voltage switchboard (M/C)	M/C 1A	T/B	1FL	x	Immersed in water	M/C 2A	T/B	B1FL	x	Submerged	M/C 3A	T/B	B1FL	x	Submerged
	M/C 1B	T/B	1FL	x	Immersed in water	M/C 2B	T/B	B1FL	x	Submerged	M/C 3B	T/B	B1FL	x	Submerged
	M/C 1S	T/B	1FL	x	Immersed in water	M/C 2SA	M/C 2SA Building	1FL	x	Submerged	M/C 3SA	C/B	B1FL	x	Submerged
						M/C 2SB	T/B	B1FL	x	Submerged	M/C 3SB	C/B	B1FL	x	Submerged
Emergency Power center (P/C)	P/C 1C	C/B	B1FL	x	Submerged	P/C 2C	T/B	1FL	○	Base portion is immersed in water	P/C 3C	T/B	B1FL	x	Submerged
	P/C 1D	C/B	B1FL	x	Submerged	P/C 2D	T/B	1FL	○	Base portion is immersed	P/C 3D	T/B	B1FL	x	Submerged
Regular Power center (P/C)	P/C 1A	T/B	1FL	x	Immersed in water	P/C 2A	T/B	1FL	○	Base portion is immersed in water	P/C 3A	T/B	B1FL	x	Submerged
						P/C 2A-1	T/B	B1FL	x	Submerged	-	-	-	-	-
	P/C 1B	T/B	1FL	x	Immersed in water	P/C 2B	T/B	1FL	○	Base portion is immersed in water	P/C 3B	T/B	B1FL	x	Submerged
	P/C 1S	T/B	1FL	x	Immersed in water	-	-	-	-	-	P/C 3SA	C/B	B1FL	x	Submerged
	-	-	-	-	-	-	-	-	-	-	-	-	-	-	-
	-	-	-	-	-	P/C 2SB	T/B	B1FL	x	Submerged	P/C 3SB	C/B	B1FL	x	Submerged
Direct current 125V	125V DC BUS-1A	C/B	B1FL	x	Submerged	125V DC DIST CTR2A	C/B	B1FL	x	Submerged	125V DC Main bus panel 3A	T/B	MB1FL	○	-
	125V DC BUS-0B	C/B	B0FL	x	Submerged	125V DC DIST CTR2A	C/B	B0FL	x	Submerged	125V DC Main bus panel 2B	T/B	MB0FL	○	-
	-	-	-	-	-	125V DC 2D/G B main bus panel	Shared pool	B1FL	x	Submerged	-	-	-	-	-

	Units 4-6														
	Unit 4					Unit 5					Unit 6				
	Component	Installation site	Installation floor	Availability for use	Condition	Component	Installation site	Installation floor	Availability for use	Condition	Component	Installation site	Installation floor	Availability for use	Condition
Starting transformer	STr(3SB)	Transformer yard	Above the ground	Unclear	Cannot be checked (Note 1)	STr(5SA)	Transformer yard	Above the ground	○	-	STr(5SB)	Transformer yard	Above the ground	○	-
Cable	OF Cable (Switchyard - STr(3SB))	-	Underground	Unclear	Cannot be checked (Note 2)	OF Cable (Switchyard - STr(5SA))	-	Underground	○	-	OF Cable (Switchyard - STr(5SB))	-	Underground	○	-
D/G	DG 4A	T/B	B1FL	x	Submerged (Under repair)	DG 5A	T/B	B1FL	x	Associated equipment (Exciter) is submerged	DG 6A	C/S	B1FL	x	Associated equipment (Sea water pump) is submerged
	DG 4B	Shared pool	1FL	x	M/C Submerged Cannot be used	DG 5B	T/B	B1FL	x	Associated equipment (Exciter) is submerged	DG 6B	DG building	1FL	○	-
Emergency high voltage switchboard(M/C)	M/C 4C	T/B	B1FL	x	Submerged (Under inspection)	M/C 5C	T/B	B1FL	x	Submerged	M/C 6C	C/S	B2FL	○	-
	M/C 4D	T/B	B1FL	x	Submerged	M/C 5D	T/B	B1FL	x	Submerged	M/C 6D	C/S	B1FL	○	-
	M/C 4E	Shared pool	B1FL	x	Submerged	-	-	-	-	-	HPCS DG M/C	C/S	1FL	○	-
Regular high voltage switchboard (M/C)	M/C 4A	T/B	B1FL	x	Submerged	M/C 5A	C/B	B1FL	x	Submerged	M/C 6A-1	T/B	B1FL	x	Submerged
	M/C 4B	T/B	B1FL	x	Submerged	M/C 5B	C/B	B1FL	x	Submerged	M/C 6A-2	T/B	B1FL	x	Submerged
	-	-	-	-	-	M/C 5SA-1	C/B	B1FL	x	Submerged	M/C 6B-1	T/B	B1FL	x	Submerged
	-	-	-	-	-	M/C 5SA-2	C/B	B1FL	x	Submerged	M/C 6B-2	T/B	B1FL	x	Submerged
	-	-	-	-	-	M/C 5SB-1	C/B	B1FL	x	Submerged	-	-	-	-	-
Emergency Power center (P/C)	P/C 4C	T/B	1FL	-	Under repair	P/C 5C	T/B	B1FL	x	Immersed in water	P/C 6C	C/S	B2FL	○	-
	P/C 4D	T/B	1FL	○	-	P/C 5D	T/B	B1FL	x	Immersed in water	P/C 6D	C/S	B1FL	○	-
	P/C 4E	Shared pool	B1FL	x	Submerged	-	-	-	-	-	P/C 6E	DG Building	B1FL	○	-
Regular Power center (P/C)	P/C 4A	T/B	1FL	-	Under repair	P/C 5A	C/B	B1FL	x	Immersed in water	P/C 6A-1	T/B	B1FL	x	Immersed in water
	-	-	-	-	-	P/C 5A-1	T/B	2FL	○	-	P/C 6A-2	T/B	B1FL	x	Immersed in water
	P/C 4B	T/B	1FL	○	-	P/C 5B	C/B	B1FL	x	Immersed in water	P/C 6B-1	T/B	B1FL	x	Immersed in water
	-	-	-	-	-	P/C 5B-1	T/B	2FL	○	-	P/C 6B-2	T/B	B1FL	x	Immersed in water
	-	-	-	-	-	P/C 5SA	C/B	B1FL	x	Immersed in water	-	-	-	-	-
Direct current 125V	125V DC Main bus panel 4A	C/B	B1FL	x	Submerged	125V DC Main bus panel 5A	T/B	MB1FL	○	-	125V DC PLANT DISTR CENTER 6A	T/B	MB1FL	○	-
	125V DC Main bus panel 3B	C/B	B0FL	x	Submerged	125V DC Main bus panel 4B	T/B	MB0FL	○	-	125V DC PLANT DISTR CENTER 5B	T/B	MB0FL	○	-
	125V DC 4D/G B Main bus panel	Shared pool	B1FL	x	Submerged	-	-	-	-	-	125V DC HPCS DISTCTR	C/S	1FL	○	-

Availability for use: Judgment of employees of Tokyo Electric Power Company after checking the condition of the equipment on the site
 Immersed in the water: Condition with the traces of immersion
 Submerged: Water is accumulated
 ○: Component that cannot be used
 ■: Although the D/G main part was not submerged, it cannot be used by submersion of M/C, associated equipment, etc.
 ■: M/C at the load dispatching source cannot be used, so electricity cannot be received
 T/B: Turbine building
 C/B: Control building
 C/S: Reactor combination building

Note 1: Since the radiation dose is high
 Note 2: As submerging of installation site is assumed

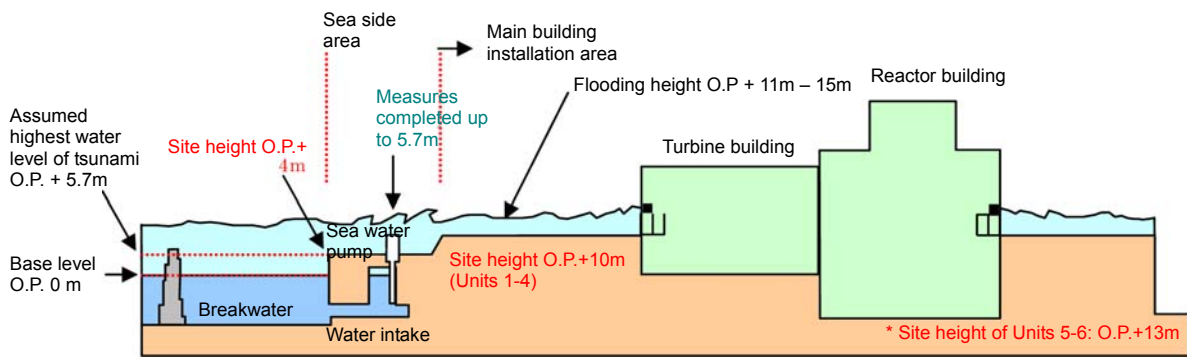

Figure 2.1-3 Situation of tsunami

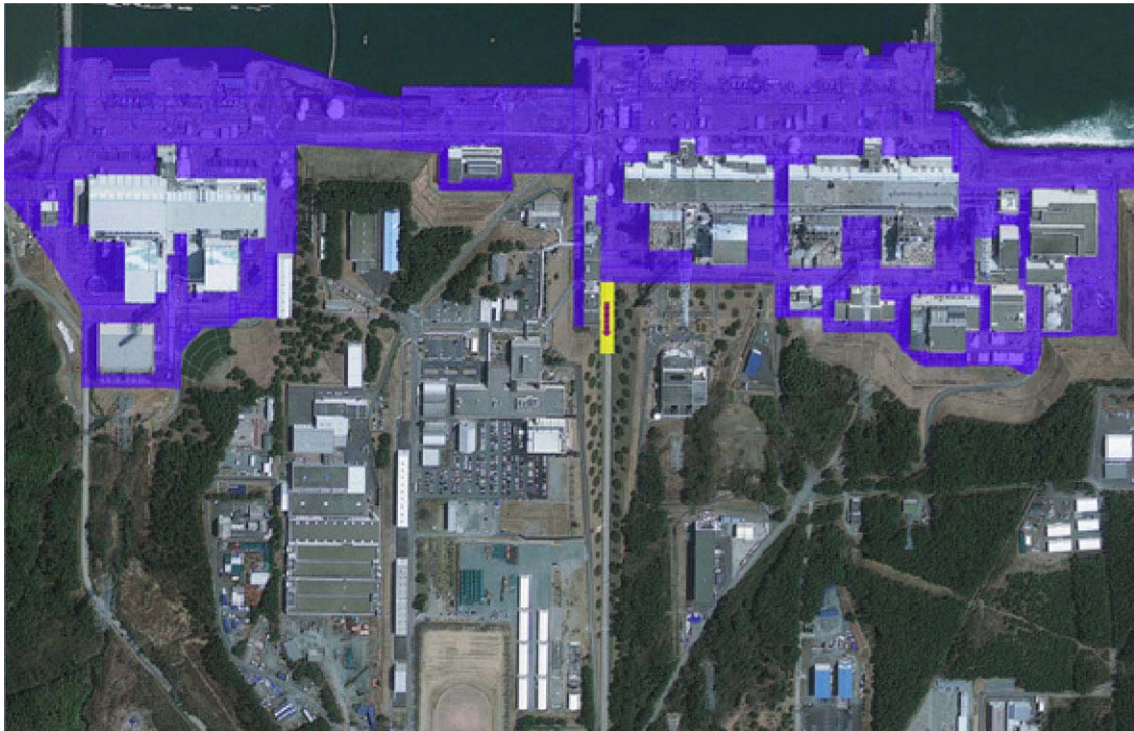

Figure 2.1-4 Extent of flooding within the power plant

2.2 Course of accident at Unit 1

2.2.1 Conditions from earthquake to arrival of tsunami

While Unit 1 was operating at a fixed rated electric output (460 MWe), it automatically stopped in response to the signal [Peak Earthquake Acceleration] which was due to the Great East Japan Earthquake which occurred at 14:46 on March 11, 2011 and all the control rods (CR) were inserted.

Due to the impact of the earthquake, the circuit breaker of Okuma line 1L, 2L was damaged and hence the outside power supply was completely lost and electricity from the emergency busbar was also lost. Hence, immediately two emergency DGs (1A, 1B) started automatically and electricity to the emergency busbar was recovered.

At 14:47 on March 11, due to the loss of electricity to the emergency busbar, the electricity was lost for the reactor protection system and hence, MSIV was shutdown automatically by a fail -safe system. The nuclear reactor pressure rose due to the MSIC shutdown and at 14:52 on March 11, the 2 ICs started automatically in response to the signal [Reactor Pressure High (7.13 MPa [gage])]. The reduction of pressure and cooling of nuclear reactor was started and the nuclear reactor pressure suddenly started declining.

The nuclear reactor water level became very low for a moment, due to a smashing of a void immediately after the automatic shutdown of nuclear reactor; however, the feed water to the nuclear reactor continued till the nuclear reactor feed water pump was tripped after the loss of external electricity. The water level did not reach a low level when the HPCI started automatically and was restored and changed to an almost normal water level.

The workers concluded that the decrease in nuclear reactor pressure that occurred when the IC started was fast and the rate of decrease in temperature of the nuclear reactor cooling material was not observed to be 55°C/h, as decided by the operation manual. Hence, at 15:03, March 11, for regulating of nuclear reactor pressure, 2 IC devices were manually stopped (IC piping isolation reverse valve MO-3A,3B [close] operation). Thereafter, startup and shutdown of IC series 1 (A) started (IC piping isolation reverse valve MO-3A [start], [close] operation) was repeated and nuclear reactor pressure was regulated to approximately 6 to 7 MPa [gage].

On one side, MSIV stopped automatically; hence, in order to execute cooling of S/C, the workers manually started the containment cooling system (hereafter called "CCS") and thus started cooling the S/C from 15:07 to 15:10 on March 11.

As mentioned above, the normal loss of external power supply meant that support after scram operation of reactor was carried out during the time from the occurrence of the earthquake to the arrival of the tsunami.

2.2.2 Situation of nuclear reactor building from tsunami to hydrogen explosion

On March 11, approximately 51 minutes after the earthquake, at 15:37, due to the tsunami, power connection to the seawater cooling pump flooded. As a result of it being submerged, the two emergency DGs stopped and resulted in a complete power loss. As a result, the Station decided that the situation corresponded to Special Law for Nuclear Emergency Article 10 (Complete loss of AC power supply).

Accompanying this Complete Loss of AC Power supply, while the MCR illumination, signal light had gone out gradually, a warning sound also ceased. The illumination of Unit 1 was emergency lights only. Unit 2 was in complete darkness.

The equipment operating on DC power supply were IC and HPCI. But after examining the situation, the workers were unsure whether the IC had an open or closed valve and the HPCI also had its indicator lit up and did not start and was turned off on the control panel.

As the power supply of the instrument had been lost, the reactor water level had been uncertain since 15:30 on March 11. At 16:36 on March 11, as the flood water situation in the reactor was unknown, the Station decided that the situation corresponded to Article 15 of the Act on Special Law of Emergency Preparedness for Nuclear Disaster (Non-emergency core cooling system priming). After that, at 16:45 on March 11, the situation recovered from the Special Law for Nuclear Emergency Article 15 as the reactor water was restored, but at 17:07 on March 11 the Station decided that the situation corresponded to Article 15 of the Act on Special Law of Emergency Preparedness for Nuclear Disaster as the reactor water level was unknown.

At 17:12 on March 11, to securely inject water to the reactor, the power plant manager (Power Station Emergency Division) instructed the workers to investigate the extinguish fire system (hereafter called "FP"), MUWC, CCS and alternate injection at a fire engine as one of the accident management measures.

Then, simultaneously with the alternate injection, an open process investigation started at the containment (called "PCV") vent because there was no power.

The support status of PCV vent and alternate injection is separately described below.

Support status of alternative injection

At Headquarters of Power plant emergency response (hereafter called "headquarters for the power plant"), it was decided to use D/D-FP, instead of FP line using core spray system (hereafter called "CS") as an alternative to alternate injection. At 17:30 on March 11 D/D-FP was started.

Due to the loss of power on valve operation of the alternate injection line, the tasks to be performed during the operation could not be performed. Because of this, the nuclear reactor building (hereafter called "R/B") was in total darkness, and the CS and other valves were opened manually. As there was a possibility

that the reactor had been flooded after depressuring (below 0.69 MPag), time was required to perform difficult tasks.

The power plant restoration team from the headquarters investigated the degree to which the power panel (high voltage power supply board and power center) had been submerged and damaged, and applied insulation resistance material. The power panel of Unit 1 was found to be out of service, one part (P/C-2C, P/C-2D) of the power center of the adjoining Unit 2 was confirmed to be available. Hence, workers investigated the possibility of restoring power by using the Unit 2 power center so as to make it possible to use the high pressure injection system (hereinafter called SLC).

At 17:00 on March 11, electricity distribution Tokyo head office instructed all its branches to secure high and low voltage power cars and confirm the routing to Fukushima Daiichi and requested Tohoku Electric Power to dispatch a high voltage power supply vehicle. Although power supply cars of all bases headed toward Fukushima, due to the damaged roads and congestion they were not advancing as expected. Apart from that, air transport of power supply vehicles from the self-defense force, and the US armed forces was investigated but the idea was abandoned as the vehicles were too heavy.

As the temporary DC power supply system to the IC was restored, the supply line isolation valve of IC (A system) MO-2A and return piping isolation valve MO-3A was indicated as being in closed by the indicator lamp. Hence at 18:18 on March 11, the MO-2A valve and MO-3A valve of IC (A system) were opened and it was confirmed that steam was coming out from the IC system vent pipe (condenser steam emission pipe). After that, at 18:25 the piping isolation valve MO-3A was closed.

Meanwhile, the condition of 4 isolation valves (MO-1A, MO-1B, MO-4A, MO-4B) between IC (B System) and PCV was uncertain as the electric power to the display lamp had been lost.

In the central operating room, due to the loss of electrical power, the indicated value of the monitoring instruments was unclear, and so the worker entered the reactor building (R/B), which was in total darkness, to examine the pressure gauge. As a result, at 20:07 on March 11, on the atomic pressure gauge the pressure was found to be 6.9 MPa [gage].

To restore the lighting and monitoring instruments in the central operating room, the headquarters of the power plant restoration team accumulated the necessary batteries and cables. On At 20:49 on March 11, temporary lighting was used in the central operating room using a small generator. Also by connecting a temporary battery to the monitoring instrument, it was identified that the nuclear reactor water level (fuel range) was +200 mm from TAF on the meter. (Note)

It was confirmed that steam was in the IC vent pipe once again at 21:30 on March 11 after opening the return line Isolation valve MO-3A. After that, as the radiation dose was raised in the R/B, at 21:51 on March 11 entering in the R/B was banned. At 22:00 on March 11, an alarm pocket dosimeter (hereafter called "APD") in the R/B showed 0.8 mSv after a short time and that radiation dose at the site had increased was reported to the headquarters of the power plant.

Again at 23:00 on March 11 radiation doses on the north side double door of T/B1 floor (R/B entrance) were 1.2 mSv/h, and 0.5 mSv/h on the south side double door.

At 01:48 on March 12, it was found that D/D-FP, which was in operational status for nuclear reactor injection, had stopped, so battery exchange, refuel and such like were carried out for restoration, but it was not possible to start D/D-FP. Because of that, the workers investigated using a fire engine and tying up a water hose for injection. Along with spraying the water from a hydrant, using the filtered water tank as a source was not found to be possible, hence the Station decided to search for a water source in the earth and use fire extinguisher tanks.

Out of 3 fire tanks at the power plant, one had been damaged by the tsunami, one was deployed at units 5 and 6 and was difficult to remove due to road damage and rubble from the tsunami. The management planned to deploy the remaining one at Fukushima Daiichi but due to the rubble from the tsunami, a quite bit of time was spent for moving the unit.

On one side, the nuclear reactor at around 2:45 on March 12 was found to have a reactor pressure that had declined to 0.8 MPa [gage]. At around 3:45 on March 12, when the double door of R/B was opened for radiation measurement, a white haze was seen and hence the doors were rapidly closed and the workers abandoned the idea of measuring the radiation.

At around 4:30 on March 12, an aftershock occurred and a tsunami warning was issued. As a result, the headquarters of the power plant ordered to stop fieldwork.

The fire engine pump house connection to Fukushima Daiichi FP line water output gate was completed. As a result, from 5:46 on March 12 fresh water injection from a fire tank to the nuclear reactor was started.

At around 5:52 on March 12, the injection volume from the fire engine became 1,000 liters, and after that, at around 9:15 on March 12, the fresh water injection was 6,000 liters, and on the same day by 9:40 it was 21,000 liters.

Moreover, further arranged fire engines arrived and it became possible to transfer fresh water from the fire tank at Unit 3 to that at Unit 1. However, only one hose could be connected to the fire tank, so the fresh water supply to the reactor needed to be discontinued.

Thus, by March 12 at 14:53, a total of 80,000 liters of fresh water had been injected.

Due to the limitations of the fire tank fresh water, concurrent with the fresh water infusion, seawater infusion was arranged. On March 12 at 14:54 the power director ordered the infusion of seawater in the reactor. From the situation at the site, the water source of seawater had been deemed to have flowed back to the unit 3 backlash valve. To ensure lightweight, a 3 fire engines was connected in series to Unit 3 and an injection line for the reactor was configured.

Alternately using a fire pump engine and concurrent infusion, the SLC power restoration also advanced. High voltage power supply cars and the Unit 2 power

center, which was not impacted by the tsunami, were used and a cable was connected to the low voltage power supply board of Unit 1. Thus, at around 15:30 on March 12 the SLC power supply was restored and SLC injection preparation was completed

Note: In the Instrument display, water level at the core is shown as ensured level but considering damage to the core and such like there was a possibility that the display of the instrument was inaccurate.

Support status at PCV Vent

On March 11 in the evening, the workers progressed to study the operating procedure of the PCV vent line valve in a situation where there was no power. They found that in a small valve of the S/C vent valve (AO valve), there was a small handle for manual operation so the workers confirmed that manual opening operation is possible and they continued preparing to conduct PCV vent.

On top of the lack of power supply to instruments due to the tsunami, the D/W pressure also was uncertain. On March 11 at 23:50, when operating a small generator that had been set up for temporary lighting in the central operating room used to supply power to the D/W pressure gauge, after comparing the indicated value the workers found it to be 600 kPa [abs], the maximum allowed pressure for D/W was 528 kPa [abs] (427 kPa [gage]). Thus, they found it to be excessive during temporary lighting operation using a small generator. Hence, at 0:06 on March 12, the plant manager ordered workers to prepare for the PCV ventilation, and they went on to confirm the concrete operation method and procedure for PCV ventilation line valves.

At 0:30 on March 11, complete evacuation of the residents in a 3 km radius occurred. (1:45 Reconfirmation & Implementation.)

At 0:49 on March 12, as there was a chance that the D/W pressure would go beyond 600kPa [abs], the Station decided that the situation corresponded to Article 15 of the Act on Special Law of Emergency Preparedness for Nuclear Disaster (abnormal increase in the containment vessel pressure).

At 1:30 on March 12, the Plant applied to TEPCO regarding PCV vent implementation at Unit 1 and 2, and also obtained the consent of the Prime Minister, Minister of Economy and Nuclear Safety and NISA. (Note: Later, after understanding that the reactor core isolation cooling system of Unit 2 was working, the PCV vent of Unit 1 was implemented as a priority.)

At 2:24 on March 12, the working hours and exposure dose of PCV vent field operations was evaluated. In the case of an atmospheric dose of 300 mSv/h, the emergency dose limit (100 mSv/h), possible working hours are 17 minutes. In the case of self-air set equipment, the time is 20 minutes. So the Station evaluated that workers must receive iodine doses.

At 2:30 on March 12, the D/W pressure increased to 840 kPa [abs]

At 3:06 on March 12, a press release was issued about the PCV vent implementation.

At 3:45 on March 12, the Station reported to the TEPCO headquarters about the exposure and results of dose assessment around the power plant during PCV vent.

At 4:45 on March 12, the APD which was set to 100 mSv and front masks arrived at the central operating room from the headquarters of the power plant.

At 4:50 on March 12, pollution was seen on the workers returning from the seismic isolation building. Thus, while entering the site from the seismic isolation building equipment [front mask, charcoal filter, B equipment, C equipment or Cover All] were set.

At 4:55 on March 12, the radiation dose in the power plant increased. (Near the main entrance, it went from 0.069 μ Sv/h at 4:00 to 0.59 μ Sv/h at 4:23.)

At around 5:00 on March 12, workers were instructed to use (front mask and charcoal filter and B equipment) even in the central operating room. As the radiation dose toward the Unit 1 side rose in the central operating room, workers were evacuated to the low radiation dose side of Unit 2 by the shift supervisor.

As the radiation dose in the power plant was rising and the D/W pressure was falling, the Station concluded that the power plant had leaked radioactive material at 5:14 on March 12.

At 5:44 on March 12, the Prime Minister announced that residents staying within a 10 km of radius of Fukushima Daiichi must evacuate.

At 6:50 on March 12, the Ministry of Economy sent instructions for a PCV vent based on regulations for nuclear power plants.

In this context, at 7:11 on March 12, the Prime Minister visited Fukushima Daiichi for inspection and left for Tokyo at 8:40.

At 8:03 on March 12, the power plant manager ordered PCV vent to be performed at 09:00 and prepared a three -member team system with a shift supervisor and 2 deputy of duty class workers.

At 8:27 on March 12, the Station understood that the evacuation of some residents of Okuma City had not been completed. Hence on March 12 at 8:37, they told Fukushima that the PCV vent was going to be started at 9:00, and adjusted the PCV vent implementation so that it would be conducted after Okuma City residents had evacuated.

At 9:03 on March 12, it was confirmed that the residents of Okuma City (Kumachi-ku) had evacuated. An official announcement of PCV vent implementation was made to Fukushima at 9:05.

At 9:04 on March 12, out of 2 valves in the PCV vent line series, initially to open the MO valve, Team 1 (2 members) went to the site. At 9:15 the MO valve was opened about 25% manually as per the procedure.

Subsequently, at 9:24 on March 12, Team 2 (2 members) headed to the torus chamber of the site to manually open the remaining AO valve (small valve) at the vent line by S/C. But because of a high radiation dose and there was a possibility that a dose limit exceeded 100 mSv, they abandoned the operation and returned to the central operating room. Team 3 (2 members) also abandoned the operation due to the high radiation dose.

As it was not possible to open the AO valve at vent line from the site by S/C, the power plant headquarters began to look into the feasibility of connecting a temporary air compressor to the stopped air in the instrument (hereafter called "IA"). And expecting residual pressure in the IA system, the AO valve (small valve) in the vent line was opened from the central operating room.

On March 12 at 10:17, in the central operating room, the first opening operation was done by S/C on the AO valve (small valve) on the vent line. In connection with this, on March 12 at 10:23 (2nd time) and 10:24 (3rd time) the same AO valve opening operation was done. Note: Confirmation could not be obtained whether the AO valve was opened or not for the 3rd time.

On March 12 at 10:40, the radiation dose of the main gate and monitoring post (hereafter called "MP"), was measured and the radiation doses were found to have gone up temporarily. On March 12 at 11:15 the radiation dose decreased, so it was assumed that there was a possibility that the PCV vent valve had not been open sufficiently.

For that reason, to open the AO valve (large valve), on March 12 from 12:30 onwards the workers continued to prepare a temporary air compressor, and outside the R/B big equipment hatch, a temporary air compressor was installed and connected to IA piping connected.

On March 12 from around 14:00 onwards, the IA piping was pressurized, and D/W pressure decreased from 0.75 MPa to 0.58 MPa (at 14:50).

Hence, at 14:30 on March 12, the Station concluded that there had been a release of radioactive material from the PCV ventilation.

2.2.3 Condition of nuclear reactor building after hydrogen explosion

At 15:30 on March 12, the SLC temporary power had been restored and the SLC injection preparation had been completed, immediately after that, a hydrogen explosion occurred at the nuclear reactor building at 15:36. After this explosion, evacuation from the site was implemented, the injured, 3 TEPCO employees and 2 collaborator company employees, were rescued and transported. Seawater injection and SLC injection related preparation work was interrupted till the condition of the site and safety were confirmed.

The dose was measured (1,015 $\mu\text{Sv/h}$) at the MP of the power plant site boundary, which exceeded 500 $\mu\text{Sv/h}$. So, on March 12 at 16:27 the Station decided the situation corresponded to Article 15 of the Act on Special Law of Emergency Preparedness for Nuclear Disaster (abnormal increase in radiation dose within the power plant site boundary).

At 18:05 on March 12 the Minister of Economy ordered the workers to fill the RPV with seawater in accordance with the regulations on nuclear power plants. This was instructed by the main branch to the power plant.

At around 18:30 on March 12, after a site examination, in a condition where a great deal of rubble covered the area, a cable, which was constructed as a temporary power supply for the SLC, and a hose to inject seawater were damaged and found impossible to use. High pressure power supply vehicles were stopped. Fire engine windows were cracked but not functionally damaged.

Close to Unit 1, high radiation dose rubble was scattered. Hence, under radiation control employee's monitoring, pieces of rubble were cleaned up, hoses for relaying were gathered from outdoor fire dehydrant, and once again seawater injection was prepared.

At around 19:04 on March 12, the workers started to inject seawater into the nuclear reactor using the Unit 3 backlash valve pit as the source, and using an FP line. Moreover, on March 12 at 20:45 the workers began injecting seawater mixed with borate into the nuclear reactor.

2.2.4 Main events after accident

Regarding to restoration of power supply, on March 15, TEPCO completed testing and inspecting access to electricity from the nuclear power lines. On March 20, the power center was powered and an external power supply was ensured. Then from March 23, the necessary load cables were constructed, started to connect from the power center.

Regarding to alternative injection, on March 25, water injection was stopped and fresh water injection using a deionized water tank as the source was resumed. From March 29, water was injected by using a temporary pump. Furthermore, from April 3, electric power for this pump was changed to the original power supply.

2.2.5 Status of spent fuel pool

On March 11, 292 spent fuel rods and 100 new fuel rods were stored at Unit 1 SFP.

At 14:46, external power supply was lost in the north-eastern pacific coast of Japan, and a fuel pool cooling purification valve system (hereafter called "FPC") also stopped. Moreover, SFP cooling was possible by using the reactor shutdown cooling system (hereafter called "SHC").

Afterwards, due to the tsunami impact, all AC power supply was lost and SFP cooling functionality and make up water system functionality were lost.

The decay heat of the Unit 1 SFP fuel was evaluated as being approximately 0.18 MWt (on March 11), which was the lowest of all units in Fukushima Daiichi. From March 31 onwards, using a concrete pump vehicle, fresh water injection was started.

Table 2.2-1 Timeline of important events (Unit 1)

March 11, 2011 (Friday)

- | | |
|--------------|---|
| 14:46 | Great East Japan Earthquake struck. Automatic reactor scram. Official announcement of level 3 emergency conditions. |
| 14:47 | Automatic shutdown of main turbine, automatic startup of emergency DG. |
| 14:52 | Automatic start of IC. |
| 15:02 | Reactor subcritical confirmation. |
| Around 15:03 | In order to control the nuclear reactor pressure by IC, manual shutdown. Then, the nuclear reactor pressure control was started by IC. |
| 15:06 | Set up emergency disaster countermeasure headquarters in head office (to understand the damage caused by the earthquake, power failure recovery etc.) |
| 15:27 | Arrival of first tsunami. |
| 15:35 | Arrival of second tsunami. |
| 15:37 | Complete AC power loss. |
| 15:42 | The Station concluded that a specific situation (complete loss of AC power supply), which corresponds to the Act on Special Law of Emergency Preparedness for Nuclear Disaster had occurred and reported to the government authorities. |
| 15:42 | Official announcement of first emergency organization. Setup of emergency countermeasures headquarters. (Becomes a joint headquarters with emergency disaster countermeasure headquarters.) |
| 16:36 | Without confirming the water level in the nuclear reactor, the status of injection of water was unclear, and management concluded that the situation corresponded to specific conditions based on Paragraph 1 of Article 15 of the Act on Special Law of Emergency Preparedness for Nuclear Disaster (Emergency core cooling system (ECCS) water injection not possible) and reported to the government authorities at 16:45. |
| 16:36 | Official announcement of emergency level 2 conditions |
| 16:45 | As the workers could confirm the nuclear reactor water level, the Station concluded that a specific situation (Emergency core cooling system (ECCS) water injection not possible), based on the provisions of Paragraph 1 of Article 15 of the Act on Special Law of Emergency Preparedness for Nuclear Disaster had come to an end and reported |

- to the government authorities at 16:55.
- 17:07 Again, the workers could not confirm the nuclear reactor water level and hence, the Station concluded that the situation corresponded to specific conditions based on Paragraph 1 of Article 15 of the Act on Special Law of Emergency Preparedness for Nuclear Disaster (Emergency core cooling system (ECCS) water injection not possible) and reported to the government authorities at 17:12.
- 17:12 The power plant manager ordered workers to start investigating a method of injecting water into the nuclear reactor using fire engines and an FP line, which was established as a countermeasure for severe accidents.
- 17:30 Start D/D-FP (standby condition)
- 18:18 Reverse piping isolation valve (MO-3A) and supply piping isolation valve (MO-2A) of IC opened, Confirmation that steam was generated.
- 18:25 Reverse piping isolation valve (MO-3A) of IC closed.
- 20:49 Temporary illumination inside MCR.
- 20:50 Evacuation instruction for the citizens of Fukushima Prefecture within a radius of 2 km from Fukushima Daiichi.
- 21:19 Water level of nuclear reactor became clear, TAF +200 mm (see note).
- 21:23 Prime Minister instructed people within a radius of 3 km from Fukushima Daiichi reactor to evacuate, and those within a radius of 3 km to 10 km from the reactor to stay indoors.
- 21:30 Start operation to open the reverse piping isolation valve (MO-3A) of IC, Confirmation of steam generation.
- 21:51 As the radiation level in the nuclear reactor building rose, persons were prohibited from going inside the reactor building.
- 22:00 Confirmation that the water level of the nuclear reactor was TAF +550 mm, communicated to the government authorities and such like at 22:20.
- 23:00 Results of a survey showed that the radiation level inside T/B (T/B 1st floor north side before the double door 1.2mSv/h, T/B 1st floor south side before the double door 0.5 mSv/h) had increased and this was reported to the government authorities at 23:40.
- March 12, 2011 (Saturday)
- 0:06 Due to a possibility that the D/W pressure had exceeded 600 KPa, the plant manager ordered the main power plant to continue preparations, considering the possibility that containment venting would be

executed.

- 0:30 Confirmation that the national evacuees had taken shelter (confirmation that the citizens within a 3 km radius of Futaba City and Okuma City had taken shelter, checked again at 1:45).
- 0:49 Since there was a possibility that the D/W pressure exceeded 600 kPa abs, the Station concluded that a specific situation (abnormal rise in storage container pressure) corresponding to the provisions of Paragraph 1 of Article 15 of the Act on Special Law of Emergency Preparedness for Nuclear Disaster had arisen and reported to the government authorities at 0:55.
- Around 1:30 Obtained consent from and reported to the Prime Minister, Minister of Economy, Trade and Industry and the Nuclear and Industrial Safety Agency (NISA) about implementing venting of containment of Unit 1 and Unit 2.
- 1:48 Confirmed the shutdown of D/D-FP due to improper conditions. Started investigating whether there was proper connection from the fire engine to the water outlet of the FP line.
- 2:47 At 2:30, management told the government authorities that D/W pressure reached 840 kPa abs.
- 3:06 Conducted a press interview related to the enforcement of storage container vent.
- 4:01 Told the government authorities the results of radiation exposure evaluation assuming the storage container would be vented.
- 4:55 Confirmed increase in the radiation level (main entrance vicinity went from 0.069 $\mu\text{Sv/h}$ (at 4:00) to 0.59 $\mu\text{Sv/h}$ (at 4:23)) inside the power plant and reported to the government authorities.
- 5:14 Due to increase in the radiation level inside the power plant and reduction in D/W pressure, management judged that a leakage of radioactive material to the outside had taken place and reported to the government authorities.
- 5:44 The Prime Minister instructed the people living within a 10 km radius from Fukushima Daiichi to evacuate.
- 5:46 Started fresh water injection in nuclear reactor from the FB line using a fire engine.
- 5:52 Completed injecting 1,000 liters of fresh water using a fire engine from the FP line.
- 6:30 Completed injecting 2,000 liters (total) of fresh water using a fire engine from the FP line.

- 6:33 Confirmed the evacuation status of the region, and found that the authorities are considering transferring the evacuees of Okuma City to the capital.
- 6:50 Enforcement order based on the laws and ordinances issued by the Minister of Economy, Trade and Industry for venting (manual venting).
- 7:11 Prime Minister arrived at Fukushima Daiichi.
- 7:55 Completed injecting 3,000 liters (total) of fresh water using a fire engine from the FP line.
- 8:03 The plant manager instructed to carry out the vent operation till 9:00.
- 8:04 Prime Minister departed from Fukushima Daiichi.
- 8:15 Completed injecting 4,000 liters (total) of fresh water using a fire engine from the FP line.
- 8:27 Confirmed that part of Okuma City had not been evacuated.
- 8:30 Completed injecting 5,000 liters (total) of fresh water using a fire engine from the FP line.
- 8:37 Informed Fukushima Prefecture that workers were preparing to conduct venting operation at around 9:00. Management decided that the venting should be started after residents had evacuated.
- 9:03 Confirmed that evacuation of Okuma district was complete.
- 9:04 The person on duty went to the actual site to carry out the venting operation.
- 9:05 Issued a press announcement on the venting.
- 9:15 Completed injecting 6,000 liters (total) of fresh water using a fire engine from the FP line.
- Around 9:15 Manually opened the storage container (hereafter called "PCV") vent valve (MO valve).
- Around 9:30 Tested operation on the site of S/C vent valve (AO valve) small valve but abandoned testing due to high radiation levels.
- 9:40 Completed injecting 21,000 liters (total) of fresh water using a fire engine from the FP line.
- 9:53 Told the government authorities the results of radiation exposure evaluation assuming that the storage container would be vented.

- 10:17 Opened the S/C vent valve (AO valve) small valve of MCR (expected remaining pressure of pressurized instrumentation air system).
- 10:40 Confirmed that the radiation level of the main gate and MP had increased, so management judged there was a high possibility that radioactive material had been released during the venting.
- 11:15 Due to a reduction in the radiation level, management confirmed the possibility that venting had insufficient effects.
- 11:39 Told the government authorities that one employee of Tokyo Electric Power Corporation, who had gone inside the nuclear reactor for the vent operation, had been exposed to a radiation level of more than 100 mSv (106.30 mSv).
- 14:30 To activate the S/C vent valve (AO valve) and large valve, a temporary air compressor was setup at around 14:00. Management confirmed that the D/W pressure was reduced and made a judgment that the radioactive material was released due to venting, and reported to the government authorities and such like at 15:18.
- 14:53 Completed injecting 80 tons (total) of fresh water using a fire engine from the FP line.
- 14:54 The plant manager instructed the main power plant to start injecting seawater.
- 15:18 The restoring work of SLC was in progress, immediately after the completion of preparations, the SLC pump was to be started and injection of water into nuclear reactor was to be scheduled. Also, management reported information to the government authorities that as soon as they completed preparations, they plan to inject seawater into the nuclear reactor from the FP.
- 15:36 Power was restored using a power source vehicle, and arrangements for injecting water into the nuclear reactor using an SLC were completed.
- 15:36 Explosion occurred in the reactor building. The hose, which had been set up to inject seawater, and the electric supply system for SLC were damaged, and became unusable.
- 16:27 MP measured the radiation level as exceeding 500 μ Sv/h (1,015 μ Sv/h). Hence the Station concluded that a specific condition (abnormal increase in radiation dose within the site boundary) had occurred based on Paragraph 1 of Article 15 of the Act on Special Law of Emergency Preparedness for Nuclear Disaster and reported to the government authorities.

- Around 17:20 Departed to survey the situation of the fire engines and reactor building
- 18:05 Headquarters and power plant told there was an order from the Minister of Economy, Trade and Industry based on laws and ordinances.
- 18:25 The Prime Minister instructed the people living within a 20 km radius of the Fukushima Daiichi to evacuate.
- Around 18:30 The results of analyzing the condition of the fire engine, reactor building and such like showed that the hose that had been set up for seawater injection and power supply device of SLC had been damaged and hence were unusable.
- 19:04 Started injecting seawater using a fire engine from the FP line.
- 20:45 Started injecting seawater mixed with boric acid into the nuclear reactor.

Note: The meter indication showed that the water level of the reactor core was being maintained, but thinking about the period of reactor damage and such like, it was possible that the meter was not showing a proper indicated value.

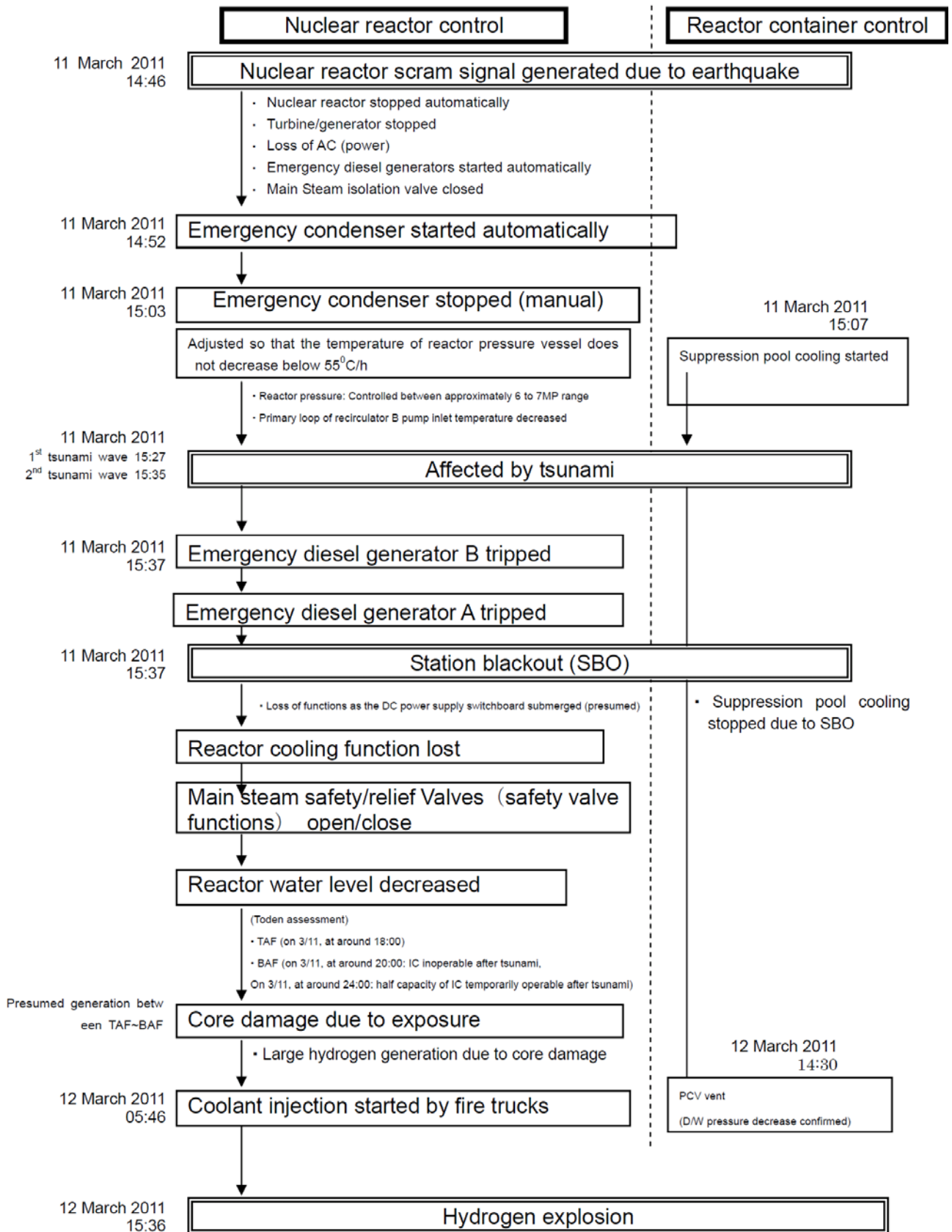

Figure 2.2-1 Course of accident after earthquake at Unit 1 of the Fukushima Daiichi Nuclear Power Station

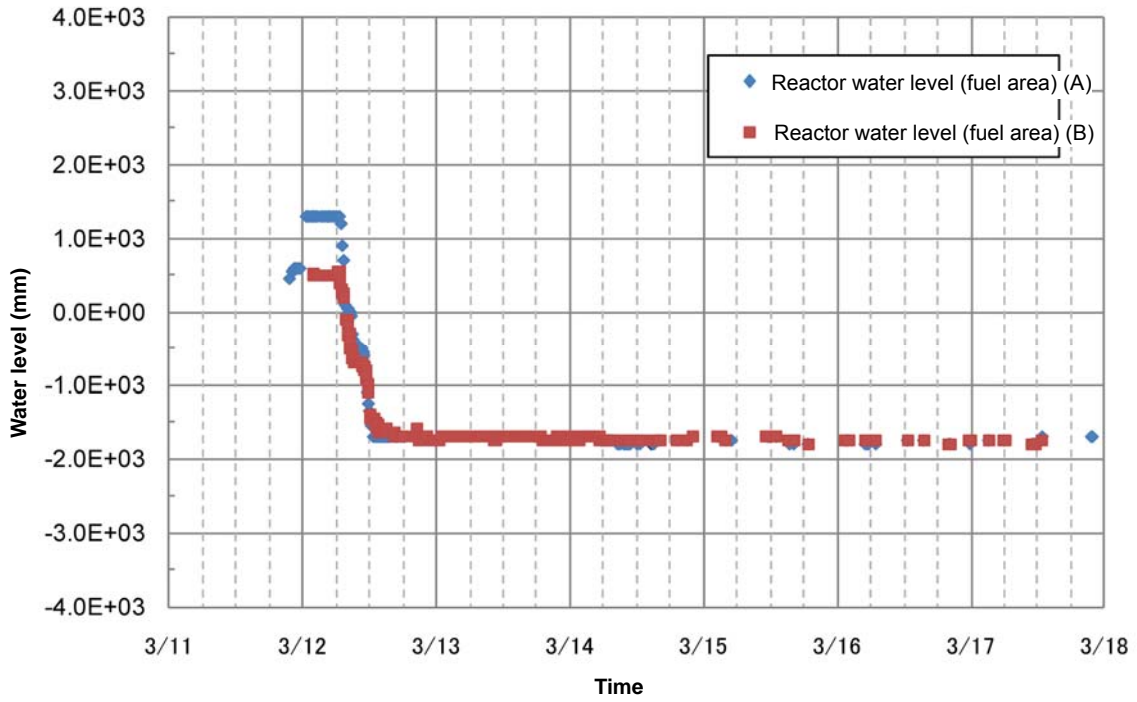

Figure 2.2-2a Change in reactor water level (Unit 1)

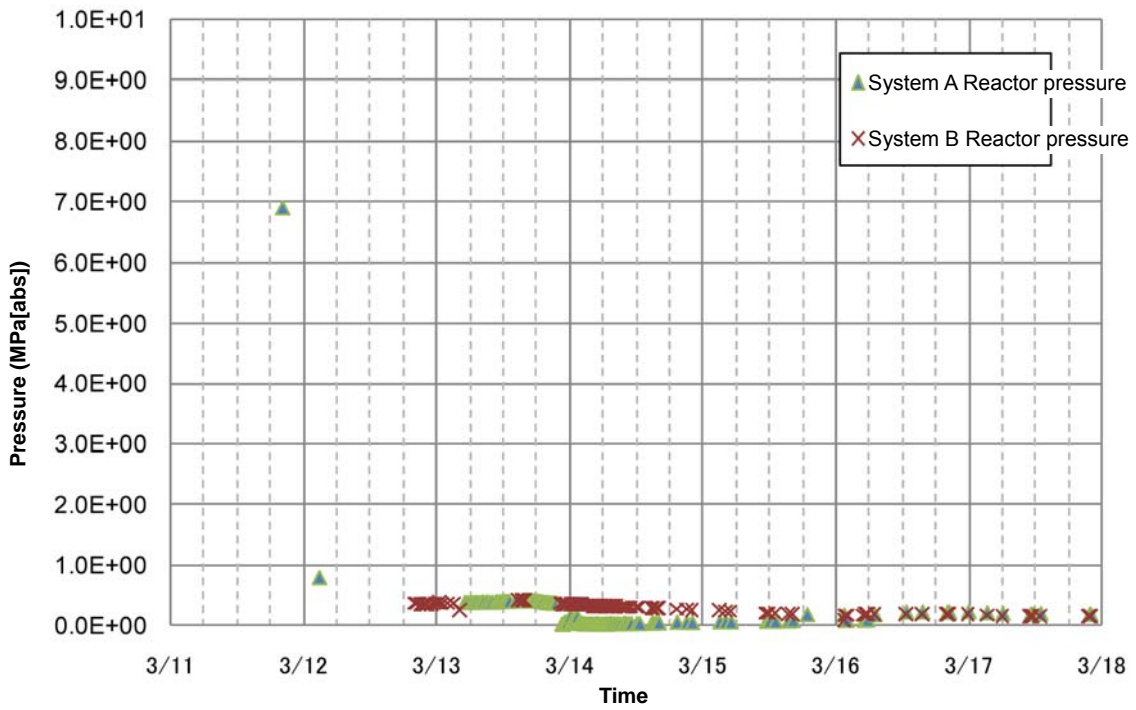

Figure 2.2-2c Changes in reactor pressure (Unit 1)

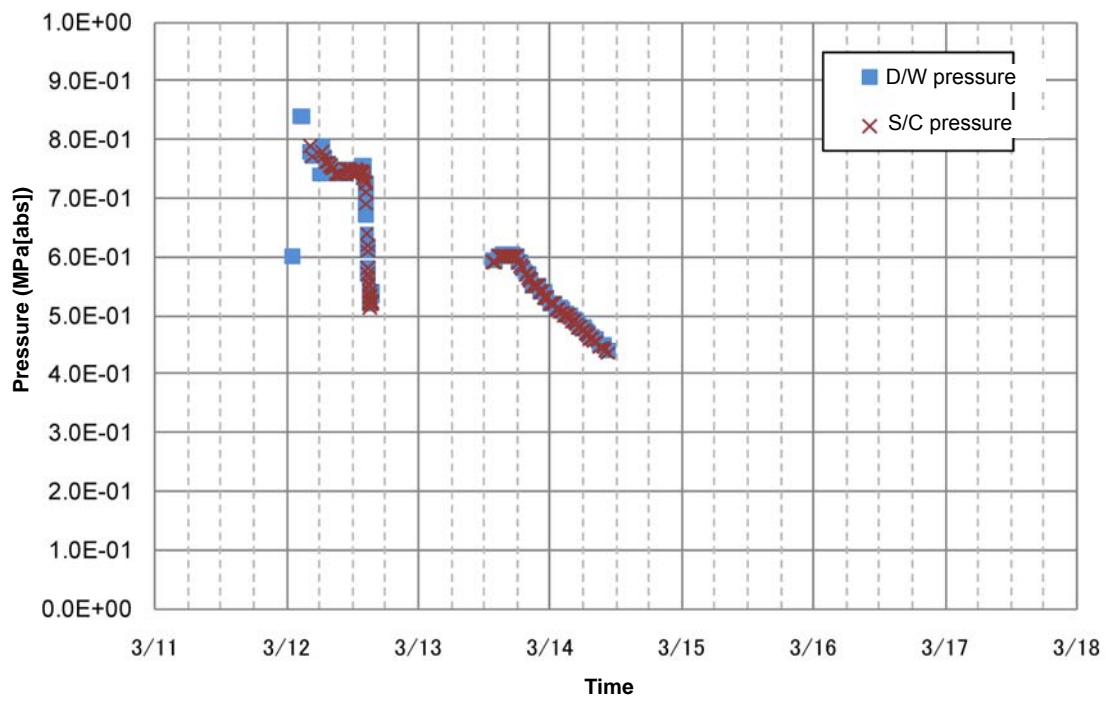

Figure 2.2-2c Changes in containment vessel pressure (Unit 1)

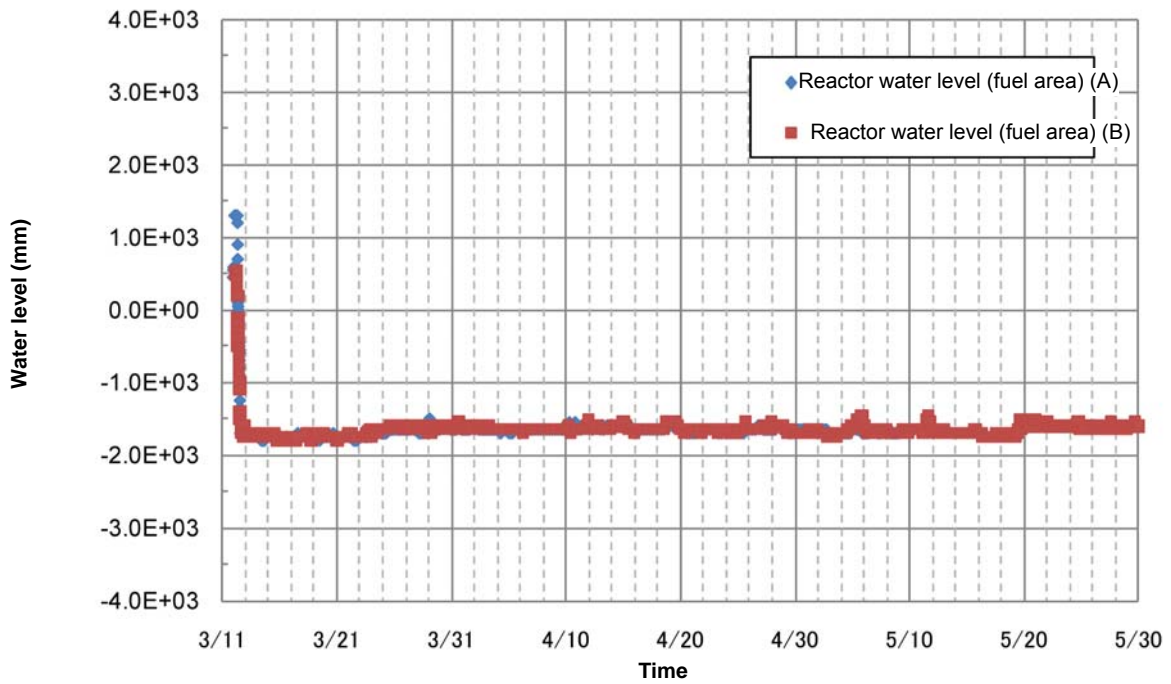

Figure 2.2-3a Changes in reactor water level (Unit 1, long term)

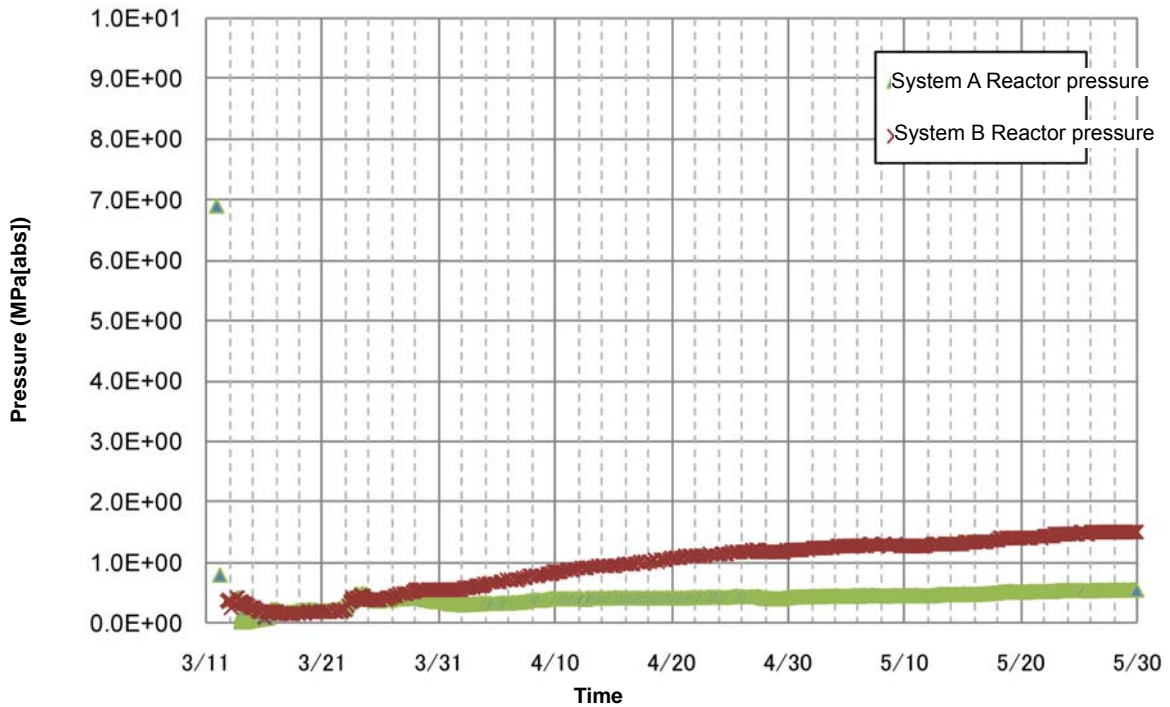

Figure 2.2-3b Changes in reactor pressure (Unit 1, long term)

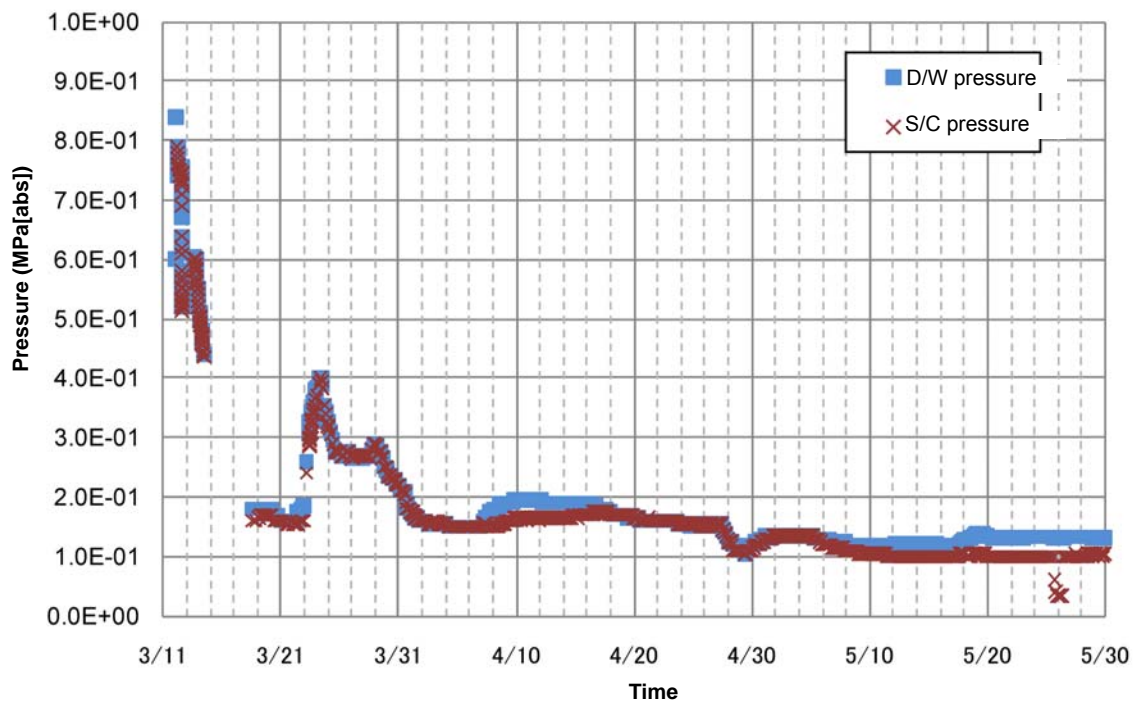

Figure 2.2-3c Changes in containment vessel pressure (Unit 1, long term)

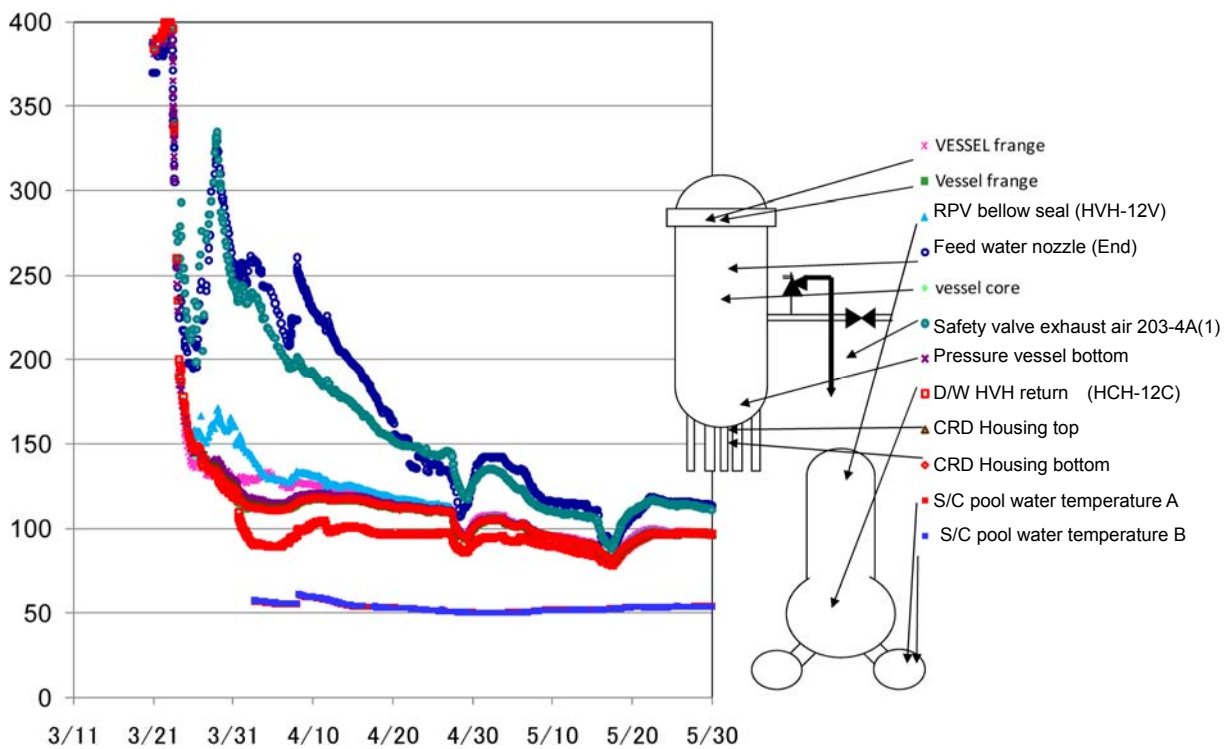

Fig. 2.2-4c Changes in temperature (Unit 1, long term)

2.3 Course of accident at Unit 2

2.3.1 From occurrence of earthquake to arrival of tsunami

Unit 2 was in constant thermal output operation at 2,381 WMt. Due to the earthquake, it automatically stalled at 14:47 on March 11 after receiving a 'large seismic acceleration' signal and all control rods were fully inserted into the reactor.

The earthquake damaged various units for the power plant, including power receiving circuit breakers for the Okuma No. 1 and 2 lines, causing a total loss of external power supply and loss of power supply for emergency bus conductors. Then, two DGs (2A and 2B) for emergency use started operating immediately and automatically to restore power supply to the emergency bus conductors.

Loss of power supply to the emergency bus conductors occurred at around 14:47 on March 11 and caused a loss of power supply for the nuclear reactor protection system, which resulted in an automatic closure of MSIV. This made the pressure in the nuclear reactor surge, but the main steam relief valve (hereafter called "SRV") controlled the pressure.

The water level in the nuclear reactor lowered immediately for a time after the nuclear reactor stopped automatically, due to a void collapse. However, after that, the level was successfully controlled by RCIC without reaching the level at which HPCI automatically starts (L-2: TAF+2,950 mm). For the RCIC, after the repetition of manual start by workers and then automatic start by receiving the 'nuclear reactor water level high' signal several times, it was manually started again at 15:39 on March 11, immediately before the massive tsunami hit the power plant.

Automatic opening and closing of the SRV and starting of the RCIC caused the temperature of the S/C pool water to rise. So, a residual heat removal system (hereafter called "RHR") was run from 15:00 to 15:07 on March 11 to cool down the S/C in the torus water cooling mode.

As mentioned above, from the time the earthquake occurred to the arrival of the tsunami, the measures taken were those normally done when external power supply is lost and there is a scram of a nuclear reactor.

2.3.2 From arrival of tsunami to malfunctioning of pressure suppression chamber

The first tsunami arrived about 41 minutes after the earthquake hit the area, i.e., 15:27 on March 11, followed by the second tsunami at 15:35. The two tsunamis flooded and soaked seawater pumps for cooling and power panels. At 15:41 on the same day, both emergency DGs (2A and 2B) stopped and a Station Black Out occurred. D/C power supply was also lost. The management determined at 15:42 on March 11 that the situation corresponded to an event applicable to Article 10 of the Act on Special Law of Emergency Preparedness for Nuclear Disaster, i.e., a Station Black Out. Due to the station blackout, the RHR and the CS were unable to function.

Workers investigated the status of RCICs that could be run using D/C power source, but were unable to detect the status because the indicator lights in the central operating room and other lights had all gone out. Moreover, power supply to the measuring instruments was lost at 15:50 on the same day and the workers could not measure the water level in the nuclear reactors and D/W pressure. The

management thus determined at 16:36 on the same day that an event applicable to Article 15 of the Act on Special Law of Emergency Preparedness for Nuclear Disaster, i.e., cooling water unable to be supplied to emergency core cooling system, had occurred.

In order to secure a measure to supply cooling water to the nuclear reactor, the plant manager issued an instruction to examine the possibility of using an alternative way of supplying cooling water including FP, MUWC and RHR, which are installed as one of the measures against severe accidents and fire engines.

In conjunction with examining an alternative cooling water supply, the procedure for opening and closing the PCV valves without power supply for ventilation of PCVs was examined.

The following explain how an alternative cooling water supply was used and how PCV ventilation was made.

Alternative Cooling Water Supply

After examinations, the disaster countermeasures office in the Fukushima Daiichi Nuclear Power Station determined to construct an alternative cooling water supply line by way of RHR and construct a system so that cooling water could be supplied after reducing the pressure in the nuclear reactor (to 0.69 MPa [gauge]) via manually operating valves installed at such places as RHR system in R/B and T/B in the total darkness.

In order to restore the lights in the central operating room and monitoring instruments, the restoration team of the Station's disaster countermeasures office collected batteries and cables required for it, and at 20:49 on the same day, temporary lighting equipment was installed in the central operation room, using a portable power generator.

The Station still did not know the water level in the nuclear reactor or how cooling water was supplied to the reactor using RCIC. The management announced there was a possibility that the water level would reach the TAF level to all relevant people at 21:02 on the same day. At the same time, relevant organizations were notified that the estimated time of reaching TAF was 21:40.

After restoring power supply to instruments and other devices using the temporary power supply system, workers discovered that the level of water in the nuclear reactor was maintained at TAF+3,400 mm, at 21:50 on the same day.

Workers investigated how the RCIC was operated on site at around 2:00 on March 12. Though they were unable to obtain the data, they found that output pressure from the RCIC pump was higher than the pressure in the nuclear reactor. Thus, they determined that the RCIC was in operation, which was informed to the central operating room.

After the report was made, the Station's disaster countermeasures office determined that the RCIC was in operation and determined to continue monitoring parameters for Unit 2, at 2:55 on March 12.

Then, the water level in the condensate storage tank (hereafter called "CST") fell from 4:20 to 5:00 on the same day, so workers went on site to manually operate the valve to switch the water source to RCIC from the CST to the S/C.

The restoration team of the Station's disaster countermeasures office investigated how a power panel of Unit 2 was inundated and how its exterior was damaged, and measured its insulation resistance. It was revealed that part of the Power Center (P/C-2C and P/C-2D) was still usable. The control rod drive system (hereafter called "CRD") pumps that can inject high-pressure water to the reactor and SLC pumps may be used to supply water to the reactor by connecting a cable from a power supply vehicle to the power center. The method to carry it out was examined.

At around 15:30 on March 12, temporary cables were connected from a high tension power supply vehicle to the primary side of the power center for Unit 2 and power connection was completed.

Immediately after the connection, at 15:36 on the same day, an explosion occurred at the R/B of Unit 1, possibly a hydrogen gas explosion. This damaged the cables, which had just been laid, and the high tension power supply vehicle automatically stopped. Due to this explosion, the workers had to evacuate from the site temporarily and the restoration work was suspended till the safety of the site was confirmed.

On March 13, the high tension power supply vehicle that was connected to the Unit 2 power center was switched on again, but its protection system (overcurrent relay) stopped it from working.

The plant manager, in preparation for stoppage of RCIC, instructed the workers to get it ready for injecting seawater into the reactor, at 12:05 on March 13. In response to this instruction, fire engines were mobilized to lay down hoses to construct a seawater injection system, with a backwash valve pit of Unit 3 as the water source.

Another hydrogen gas explosion occurred at the R/B of Unit 3 at 11:01 on March 14. This damaged the fire engines and the hoses for seawater injection, which were ready to use, and made them unusable.

An on-site investigation started at 13:05 on the same day. After confirming how debris was scattered over the affected site, fire engines that were still usable were mobilized and hoses were laid again to start preparing for construction of a water injection system again; but this time, the seawater source was changed from the Unit 3 backwash valve pit to the cargo unloading station.

On the other hand, the RCIC were in operation, and the water level in the nuclear reactor was stably moved to over TAF+3,000 mm measured by an active fuel water level gauge from 22:00 on March 11 to around 12:00 on March 14. The water level, however, showed a downing trend at around 13:18 on March 14, which continued thereafter. The management determined at 13:25 on March 14 that the situation corresponded to an event applicable to Article 15 of the Act on Special Law of Emergency Preparedness for Nuclear Disaster, i.e., loss of capacity to cool down a nuclear reactor, after RCIC lost its function.

Work to connect seawater injection lines to inject seawater to the reactor from fire engines using FP lines was completed at 14:43 on March 14.

In order to inject seawater to the reactor from the fire engines, it was necessary to reduce pressure in the reactor by manually opening the SRVs. However, the temperature and pressure of the S/C remained high (the temperature and

pressure in the S/C were 149.3 °C and 486 kPa [abs] respectively at 12:30 on March 14). The condition was such that even if the SRVs were opened manually, it was not likely that steam in the S/C would condensate and the pressure would be reduced.

So, the Station's disaster countermeasures office decided to inject seawater after ventilating the PCV to reduce the S/C pressure then to reduce the pressure inside the reactor using the SRVs.

However, thereafter, it was likely that it would take time till the PCV valve was manually opened. The plant manager, at around 16:00 on March 14, decided to reduce the pressure using the SRVs first and instructed the workers to ventilate the PCV at the same time. Preparations were made around 16:30 on the same day so that seawater injection could be started as soon as the fire engine pump was run and the pressure in the reactor was reduced to an acceptable level.

As the DC power supply to open the SRVs was lost, batteries in the vehicles that had been parked on high ground and were unaffected by the tsunami were collected to the central operating room and they were prepared to be used as a power source for operating the SRVs by connecting the batteries to the power cable. The pressure in the reactor was reduced and opening of the SRVs started at 16:34 on March 14. The voltage of the battery was not sufficient. So batteries were added and the opening operation of more than one SRV continued.

Meanwhile, the water level of the reactor reached TAF at 17:17 on March 14.

Pressure reduction by opening SRVs started at around 18:00 on March 14. However, the high temperature and pressure in the S/C prevented steam from condensing and it took time till the pressure was reduced. (The pressure in the reactor was 6.998 MPa [gage] at 16:43, 6.075 MPa [gage] at 18:03, and 0.63 MPa [gage] at 19:03 on March 14.)

During this period, at 18:22 on March 14, the water level in the reactor fell to TAF-3,700 mm and the entire fuel rods were exposed.

The radiation dose at the site was too high to have the operation condition of the fire engines monitored for a long time by the same person, so the workers took turns in monitoring. At 19:20 on the same day, fire engines waiting to inject seawater into the reactor were found to have stopped at the site due to a fuel shortage.

The fire engines were refueled and seawater injection by them using the FP line was started at 19:54 on the same day. (One each of the fire engines was operated at 19:54 and 19:57 on March 14.)

When the SRV2 valve was manually opened at 21:20 on the same day, the water level in the reactor showed a slight recovery. (The water level in the reactor was TAF-3,000 mm at 21:30 on March 14.)

PCV Ventilation

Starting from the evening of March 11, the workers examined how to open the PCV ventilation valves without any power supply, in conjunction with an examination on alternative methods for water injection.

The power supply to measuring instruments was lost due to the tsunami and the D/W pressure was unknown. However, the measuring instruments were restored

at around 23:25 on March 11 and it was found that the D/W pressure was 0.141 MPa [abs].

As it was found that RCIC for Unit 2 was in operation at 2:55 on March 12, the Station decided to ventilate the PCV of Unit 1 first and to continue monitoring the parameters for Unit 2.

Meanwhile, water injection to the reactor using RCIC was continued and the D/W pressure shifted stably around 200 to 300 kPa [abs]. However, the Station reasonably assumed that ventilation of the PCV was going to be necessary. The plant manager issued an instruction at 17:30 on March 12 to start preparing for PCV ventilation for Unit 2.

In line with the operating manual, at 8:10 on March 13, the workers manually opened the MO valve at 25%. This is one of the two valves (MO valve and AO valve) that are serially installed in the PCV ventilation line.

At 10:15 on March 13, the plant manager instructed the workers to open the remaining AO valve. Following this order, at 11:00 on the same day, the workers opened the AO valve (large valve) by forcibly energizing a solenoid valve using the power source supplied by a small-sized power generator for temporary lighting in the central operating room. This completed forming the PCV ventilation line system excluding a rupture disc. The D/W pressure at this time was still lower than the working pressure for the rupture disc (i.e., 427 kPa [gage]) and under such a low pressure, ventilation of the PCV could not be done. So the valves in the ventilation line were left open and the D/W pressure was continually monitored.

The Station informed the result of evaluating the dose of radiation exposed to the areas neighboring the plant when the PCV ventilation was done to the relevant organizations at 15:18 on March 13.

An explosion, possibly of hydrogen gas, occurred at the R/B of Unit 3 at 11:01 on March 14. All workers excluding workers at the central operating room stopped the entire work and evacuated to the antiseismic building.

The D/W pressure was shifting at around 450 kPa [abs] in a stable manner, which was lower than the working pressure for the rupture disc.

Due to the explosion in Unit 3, the circuit for energizing a solenoid valve for the AO valve (large valve), which was on the ventilation line from S/C, which was being constructed, was disconnected and closed. After the evacuation order was lifted, at around 16:00 on March 14, the workers performed an operation to open the valve again but in vain, due to an insufficient air supply from the air compressor temporarily installed, or other reasons. (Thereafter, the reason was assumed to be a malfunctioned solenoid valve.) Due to this, the workers began building a ventilation line using the AO valve (small valve) installed on the ventilation line connecting from the S/C, at around 18:35 on March 14. At around 21:00 on the same day, the AO valve (small valve) was opened and the PCV ventilation line system was recreated, excluding the rupture disc.

As the D/W pressure exceeded 427 kPa [gage], or the maximum working pressure, at 22:50 on March 14, the Station determined the situation corresponded to an event applicable to Article 15 of the Act on Special Law of Emergency Preparedness for Nuclear Disaster, i.e., abnormal pressure surge in a primary containment vessel (PCV).

The D/W pressure tended to go up but the S/C pressure was shifting around 300 to 400 kPa [abs] in a stable manner. This caused an irregular distribution of pressure in the PCVs.

As the pressure on the S/C side was lower than the working pressure of the rupture disc, and as the pressure on the D/W side surged, the Station decided at around 23:35 on March 14 to carry out a measure to initiate PCV ventilation by opening the AO valve (small valve) on the ventilation line connected from D/W.

At around 0:02 on March 15, the AO valve (small valve) on the ventilation line from the D/W was opened, but several minutes later, it closed again. The D/W pressure shifted at a high level.

At 3:00 on the same day, the workers tried to reduce the D/W pressure and inject water into the nuclear reactor but the reactor's pressure could not be reduced to a sufficiently low level.

At around 6:00 or 6:10 on March 15, a big boom was heard and around the same time, the pressure of the S/C became 0 MPa [abs].

At 6:50 on the same day, the radiation dose around the main gate showed 583.7 $\mu\text{Sv/h}$, which is higher than 500 $\mu\text{Sv/h}$ — the threshold level determined as an abnormal level of radiation. So the Station determined the situation corresponded to an event applicable to Article 15 of the Act on Special Law of Emergency Preparedness for Nuclear Disaster, i.e., abnormal surge of radiation dose at the boundary of the premises.

At around 7:00 on March 15, the workers in the antiseismic building, except for those required for emergency restoration work and monitoring, left the plant to go to Fukushima Daini Nuclear Power Station, hereafter called "Fukushima Daini" temporarily.

Thereafter, parameters such as D/W pressure were taken by the workers every few hours at the central operating room. At around 11:25 on March 15, the D/W pressure showed a decrease (730 kPa [abs] at 7:20 and 155 kPa [abs] at 11:25 on March 15).

2.3.3 Major events thereafter

Inspection and trial recharging of the Station's access to electricity from TEPCO's Nuclear Power Grid owned by Tohoku Electric Co., Ltd. were completed on March 15, and then electricity was received by the Power Center on March 20. Now an external power source had been secured. Then on March 26, the lighting of the MCR was restored.

As an alternative way to inject water into the nuclear reactor, seawater had been used up to March 26. But on the same day, fresh water supplied from temporary tanks was used. On the following day, March 27, the pumps used were changed from fire pumps to temporary electric pumps. From April 3 onward, power supply to the plant was restored from a temporary power supply system.

2.3.4 Condition of spent fuel pool

As of March 11, a total of 587 spent fuel rods and 28 new fuel rods were stored in the spent fuel pool (SFP) of Unit 2. The Station estimated that the decay heat generated by these fuels in the SFP was approximately 0.62 MWt (as of March 11).

The earthquake that occurred at 14:46 on March 11 caused a total loss of external power supply to the plant, and the FPC came to a halt. The massive tsunami that hit the plant after the earthquake caused a station blackout and the functions of cooling and supplying water to the SFP were lost.

The explosion of the R/B of Unit 1 that occurred at 15:36 on March 12 blew away the blow out panel of R/B in Unit 2 and white smoke was observed coming out of the blow out panel.

On March 20, seawater was injected to the SFP using FRC pipes already laid. When injection of seawater to the SFP was done again on March 22, the water level surged in the skimmer surge tank, meaning the SFP was totally filled with water.

From March 29 onward, the type of water was switched from seawater to fresh water.

It is considered that these water injections were successful in keeping the water level in the SFP sufficiently high to prevent the fuel rods being exposed to the air.

Table 2.3-1 Time-Course Progress (Unit 2)

March 11, 2011 (Fri.)

14:46	Great East Japan Earthquake occurs. Alert Level 3 automatically issued.
14:47	Scram of nuclear reactors automatically occurs and main turbine automatically stops. Emergency DG automatically activated.
14:50	RCIC manually started.
14:51	RCIC stops (due to high water level in the reactor).
15:01	Subcriticality of the nuclear reactor confirmed.
15:02	RCIC manually started.
15:06	A disaster countermeasures office established in the TEPCO head office (to understand the damage conditions due to the earthquake and restoration from blackout).
15:27	First tsunami arrives.
15:28	RCIC stops (due to high water level in the nuclear reactor).
15:35	Second tsunami arrives.
15:39	RCIC manually started.
15:41	Station Black Out occurs.
15:42	Determined the occurrence of a special event applicable to Paragraph 1, Article 10 of the Act on Special Law of Emergency Preparedness for Nuclear Disaster (Station Black Out). Notified the same to governmental agencies and other relevant organizations.
15:42	Alert Level 1 issued. An emergency task force established (as a joint headquarters with disaster countermeasures office).
16:36	Water level in the reactors is unable to be confirmed and how water is injected is known. So the Station determines that a special event applicable to Paragraph 1, Article 15 of the Act on Special Law of Emergency Preparedness for Nuclear Disaster has occurred (cooling water unable to be supplied to emergency core cooling system), and at 16:45 the same is notified to the governmental agencies and other relevant organizations.
16:36	Alert Level 2 issued.
17:12	The plant manager instructs workers to start an examination to find a way to inject water into the nuclear reactors using the FP lines installed in preparation for severe accidents and fire engines.
20:49	Temporary lighting installed and used within the MCR.
20:50	Fukushima Prefecture directs local residents living within a 2 km radius from the Fukushima Daiichi Nuclear Power Station to evacuate.
21:02	As the water level in the nuclear reactors is unidentified and how water is injected to them by RCIC cannot be confirmed, the Station sends a notice to governmental agencies and other relevant organizations saying that the water level could reach TAF.
21:13	The time for reaching TAF is estimated as 21:40, which is conveyed to governmental agencies and other relevant organizations.
21:23	The Prime Minister directs local residents living within a 3 km radius from the power plant to evacuate and those living within a 3 km to 10 km radius to stay indoors.
22:00	Water level in the reactors is identified as TAF+3,400 mm. So the Station assesses that it will take more time before reaching the level of TAF. The Station notifies governmental agencies and other relevant organizations of this at 22:10 and 22:20.

March 12, 2011 (Sat.)

0:30	Completion of evacuation of the local residents confirmed by the Government of Japan (confirmed evacuation of people living within 3 km from the plant in Futaba City and Okuma City, and reconfirmed it at 1:45).
------	--

Around 1:30 Ventilation of Unit 1 and Unit 2 requested to the Prime Minister, the Minister of METI and Nuclear and Industrial Safety Agency, to which an approval is granted.

2:55 Confirmed RCIC is in operation.

3:06 Held a press meeting on initiation of the ventilation.

3:33 Notified to the governmental agency of the results of radiation exposure evaluation to be released when the ventilation is done.

4:55 Confirmed surge of radiation dose within the plant premises surges (around the main gate: goes from 0.069 $\mu\text{Sv/h}$ (at 4:00) to 0.059 $\mu\text{Sv/h}$ (at 4:23). The same is notified to governmental agencies and other relevant organizations.

5:44 The Prime Minister directs local residents living within a 10 km radius from Fukushima Daiichi Nuclear Power Station to evacuate.

6:50 The Minister of METI issues an order to initiate ventilation (manual ventilation) pursuant to the relevant laws.

7:11 The Prime Minister arrives at the Fukushima Daiichi Nuclear Power Station.

8:04 The Prime Minister leaves the Fukushima Daiichi Nuclear Power Station.

16:27 A radiation dose of over 500 $\mu\text{Sv/h}$ at the MP i.e., 1,015 $\mu\text{Sv/h}$ observed and the Station determines that a special event applicable to Paragraph 1, Article 15 of the Act on Special Law of Emergency Preparedness for Nuclear Disaster has occurred (abnormal surge of radiation dose at the boundary of the premises). The same is notified to governmental agencies and other relevant organizations.

17:30 The plant manager issues an instruction to start preparation for PCV ventilation.

18:25 The Prime Minister directs local residents living within a 20 km radius from the Fukushima Daiichi Nuclear Power Station to evacuate.

March 13, 2011 (Sun.)

8:10 A ventilation valve (MO valve) of primary containment vessels (hereafter called "PCVs") is opened.

8:56 A radiation dose of over 500 $\mu\text{Sv/h}$ at the MP i.e., 882 $\mu\text{Sv/h}$ observed and the Station determines that a special event applicable to Paragraph 1, Article 15 of the Act on Special Law of Emergency Preparedness for Nuclear Disaster has occurred (abnormal surge of radiation dose at the boundary of the premises). The same is notified to governmental agencies and other relevant organizations at 9:01.

10:15 The plant manager instructs the workers to start the ventilation.

11:00 A ventilation line is established, excluding rupture discs.

11:00 The Prime Minister directs local residents living within a 20 km to 30 km radius from the Fukushima Daiichi Nuclear Power Station to stay indoors.

11:20 Held a press meeting on initiation of PCV ventilation.

12:05 The plant manager instructs workers to prepare for using seawater.

14:15 A radiation dose of over 500 $\mu\text{Sv/h}$ at the MP i.e., 905 $\mu\text{Sv/h}$ observed and the Station determines that a special event applicable to Paragraph 1, Article 15 of the Act on Special Law of Emergency Preparedness for Nuclear Disaster has occurred (abnormal surge of radiation dose at the boundary of the premises). The same is notified to governmental agencies and other relevant organizations at 14:23.

15:18 Notified governmental agencies and other relevant organizations of the result of radiation exposure evaluation to be released when PCV ventilation is done.

March 14, 2011 (Mon.)

2:20 A radiation dose of over 500 $\mu\text{Sv/h}$ at around the main gate i.e., 751 $\mu\text{Sv/h}$ observed and the Station determines that a special event applicable to Paragraph 1, Article 15 of the Act on Special Law of Emergency Preparedness

for Nuclear Disaster has occurred (abnormal surge of radiation dose at the boundary of the premises). The same is notified to governmental agencies and other relevant organizations at 4:24.

2:40 A radiation dose of over 500 $\mu\text{Sv/h}$ at the MP i.e., 650 $\mu\text{Sv/h}$ observed and the Station determines that a special event applicable to Paragraph 1, Article 15 of the Act on Special Law of Emergency Preparedness for Nuclear Disaster has occurred (abnormal surge of radiation dose at the boundary of the premises). The same is notified to governmental agencies and other relevant organizations at 5:37.

4:00 A radiation dose of over 500 $\mu\text{Sv/h}$ at the MP i.e., 820 $\mu\text{Sv/h}$ observed and the Station determines that a special event applicable to Paragraph 1, Article 15 of the Act on Special Law of Emergency Preparedness for Nuclear Disaster has occurred (abnormal surge of radiation dose at the boundary of the premises). The same is notified to governmental agencies and other relevant organizations at 8:00.

9:12 A radiation dose of over 500 $\mu\text{Sv/h}$ at the MP i.e., 518.7 $\mu\text{Sv/h}$ observed and the Station determines that a special event applicable to Paragraph 1, Article 15 of the Act on Special Law of Emergency Preparedness for Nuclear Disaster has occurred (abnormal surge of radiation dose at the boundary of the premises). The same is notified to governmental agencies and other relevant organizations at 9:34.

11:01 Explosion of R/B of Unit 3 caused the large valve of the S/C ventilation valve (AO valve) closed. Confirmed it is unable to be opened. The completed water injection line is found unable to be used due to damages to the fire engines and hoses.

13:05 Establishment of a seawater injection line restarted, including fire engines.

13:18 As the water level in the reactor tends to be lowering, the Station notifies the governmental agencies and other relevant organizations that it will immediately start preparing to inject seawater into the reactor.

13:25 The water level in the reactor keeps decreasing and there is a possibility that the RCIC is not functioning. The Station determines that a special event applicable to Paragraph 1, Article 15 of the Act on Special Law of Emergency Preparedness for Nuclear Disaster has occurred (loss of capacity to cool down a nuclear reactor). The same is notified to governmental agencies and other relevant organizations at 13:38.

15:28 Time to reach the TAF estimated as 16:30. The same is notified to governmental agencies and other relevant organizations.

16:30 Fire engines start injecting seawater into the reactor.

16:34 The Station notifies governmental agencies and other relevant organizations that it will start reducing the pressure in the nuclear reactor and injecting seawater from the FP lines.

17:17 The water level in the nuclear reactor reached TAF. The same is notified to governmental agencies and other relevant organizations at 17:25.

Around 18:00 The Station starts reducing the pressure in the nuclear reactor (from 5.4 MPa to 0.63 MPa at 19:03).

18:22 The water level in the nuclear reactor reached TAF-3,700 mm. The Station determined that the whole of the fuel rods have been exposed to the air. The same is notified to governmental agencies and other relevant organizations at 19:32.

19:20 Confirmed that fire engines that are injecting seawater into the nuclear reactor have stopped because they have run out of fuel.

19:54 Started using fire engines to inject seawater into the nuclear reactor from the FP line (one each operated at 19:54 and 19:57).

Around 21:00 A small valve of the S/C ventilation valve (AO valve) opened. A ventilation line excluding rupture discs completed.

21:20 Two valves of SRVs opened. Confirmed that the water level in the nuclear

- reactor has improved. The same is notified to governmental agencies and other relevant organizations at 21:34. (As of 21:30, the water level of the nuclear reactor is TAF-3,000 mm.)
- 21:35 A monitoring car recorded a radiation dose of over 500 $\mu\text{Sv/h}$ at the MP i.e., 760 $\mu\text{Sv/h}$ and the Station determines that a special event applicable to Paragraph 1, Article 15 of the Act on Special Law of Emergency Preparedness for Nuclear Disaster has occurred (abnormal surge of radiation dose at the boundary of the premises). The same is notified to governmental agencies and other relevant organizations at 22:35.
- 22:50 The D/W pressure exceeds its maximum working pressure, i.e., 427 kPa [gage] and the Station determines that a special event applicable to Paragraph 1, Article 15 of the Act on Special Law of Emergency Preparedness for Nuclear Disaster has occurred (abnormal pressure surge in a primary containment vessel (PCV)). The same is notified to governmental agencies and other relevant organizations at 23:39.
- Around 23:35 The pressure on the S/C side is lower than the pressure required to operate a rupture disc, and as the pressure on the D/W side is surging, the plant determined to initiate ventilation by opening a small valve of the D/W ventilation valve.
- March 15, 2011 (Tue.)
- 0:02 A small valve of the D/W ventilation valve (AO valve) opened. A ventilation line excluding rupture discs completed. (Confirmed that the valve is in closed position a few seconds later.)
- 3:00 The D/W pressure exceeds its design maximum working pressure. The Station notifies governmental agencies and other relevant organizations at 4:17 that it is working to reduce the pressure and inject water into the nuclear reactor, but the pressure still remains high.
- Around 6:00 The S/C pressure indicates 0 MPa (abs). (Around the same time, a big boom to 6:10 is heard on the premises.)
- 6:50 A radiation dose of over 500 $\mu\text{Sv/h}$ around the main gate i.e., 583.7 $\mu\text{Sv/h}$ observed and the Station determines that a special event applicable to Paragraph 1, Article 15 of the Act on Special Law of Emergency Preparedness for Nuclear Disaster has occurred (abnormal surge of radiation dose at the boundary of the premises). The same is notified to governmental agencies and other relevant organizations at 7:00.
- 7:00 Notified governmental agencies and other relevant organizations that all workers, excluding those required to remain in the plant, will evacuate to Fukushima Daini Nuclear Power Station temporarily.
- 8:11 A radiation dose of over 500 $\mu\text{Sv/h}$ around the main gate i.e., 807 $\mu\text{Sv/h}$ observed and the Station determines that a special event applicable to Paragraph 1, Article 15 of the Act on Special Law of Emergency Preparedness for Nuclear Disaster has occurred (abnormal release of radioactive substances due to a fire and an explosion). The same is notified to governmental agencies and other relevant organizations at 8:36. Confirmed white smoke (steam or the like) is generated at the 5F of the R/B at 8:25. The same is notified to governmental agencies and other relevant organizations at 9:18.
- 16:00 A radiation dose of over 500 $\mu\text{Sv/h}$ at the main gate i.e., 531.6 $\mu\text{Sv/h}$ observed and the Station determines that a special event applicable to Paragraph 1, Article 15 of the Act on Special Law of Emergency Preparedness for Nuclear Disaster has occurred (abnormal surge of radiation dose at the boundary of the premises). The same is notified to governmental agencies and other relevant organizations at 16:22.
- 23:05 A radiation dose of over 500 $\mu\text{Sv/h}$ around the main gate i.e., 4,548 $\mu\text{Sv/h}$

observed and the Station determines that a special event applicable to Paragraph 1, Article 15 of the Act on Special Law of Emergency Preparedness for Nuclear Disaster has occurred (abnormal surge of radiation dose at the boundary of the premises). The same is notified to governmental agencies and other relevant organizations at 23:20.

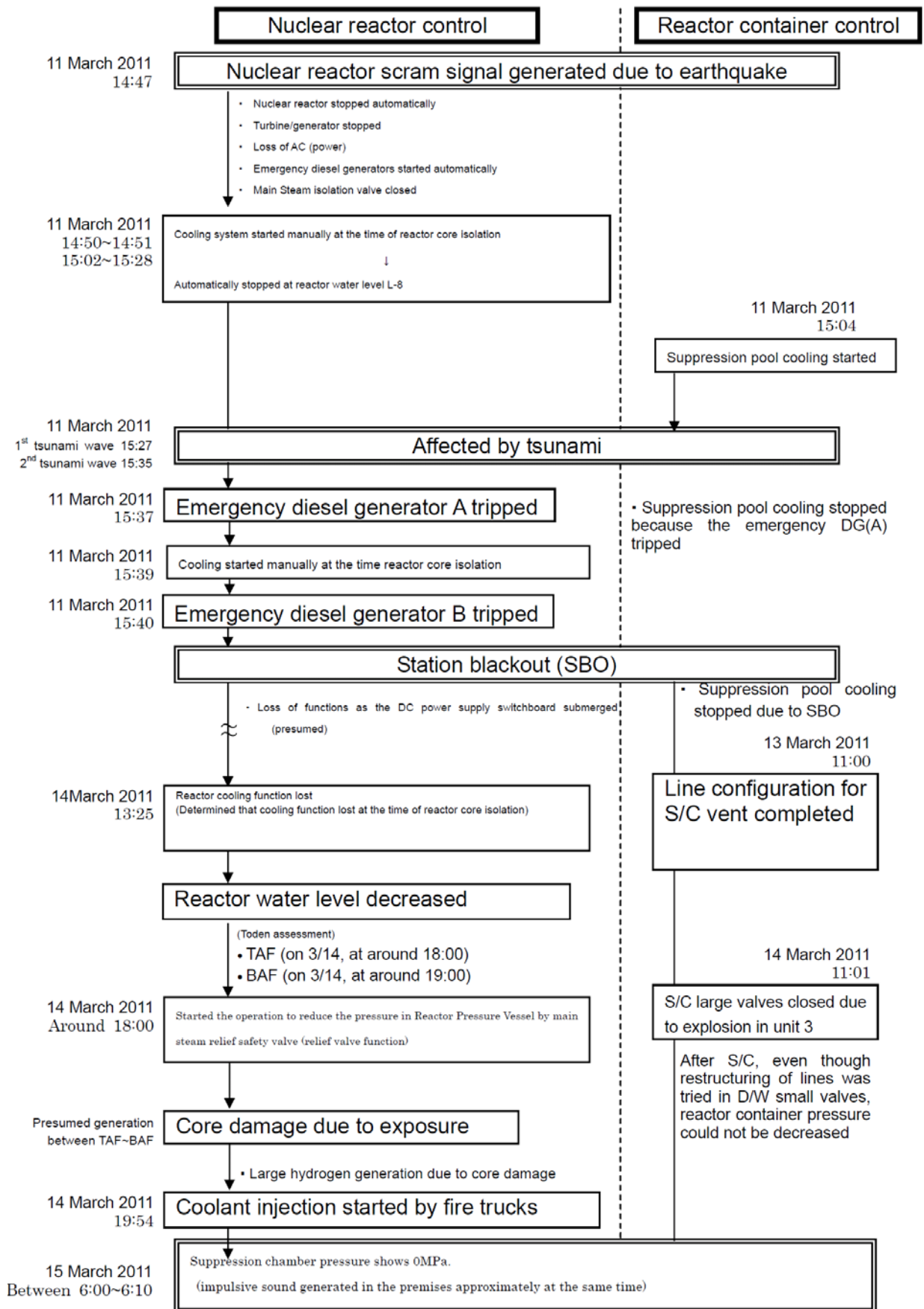

Fig. 2.3-1: Flows of the Accident at Unit 2 of the Fukushima Daiichi Nuclear Power Station after the Earthquake

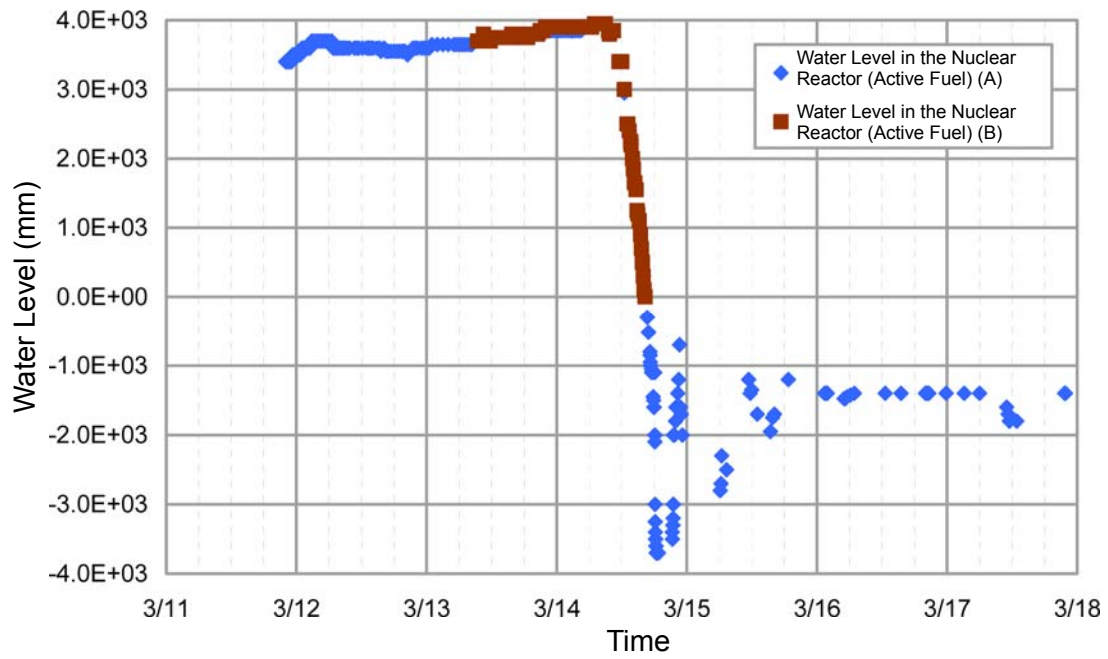

Fig. 2.3-2a: Shift of the Water Level in the Nuclear Reactor (Unit 2)

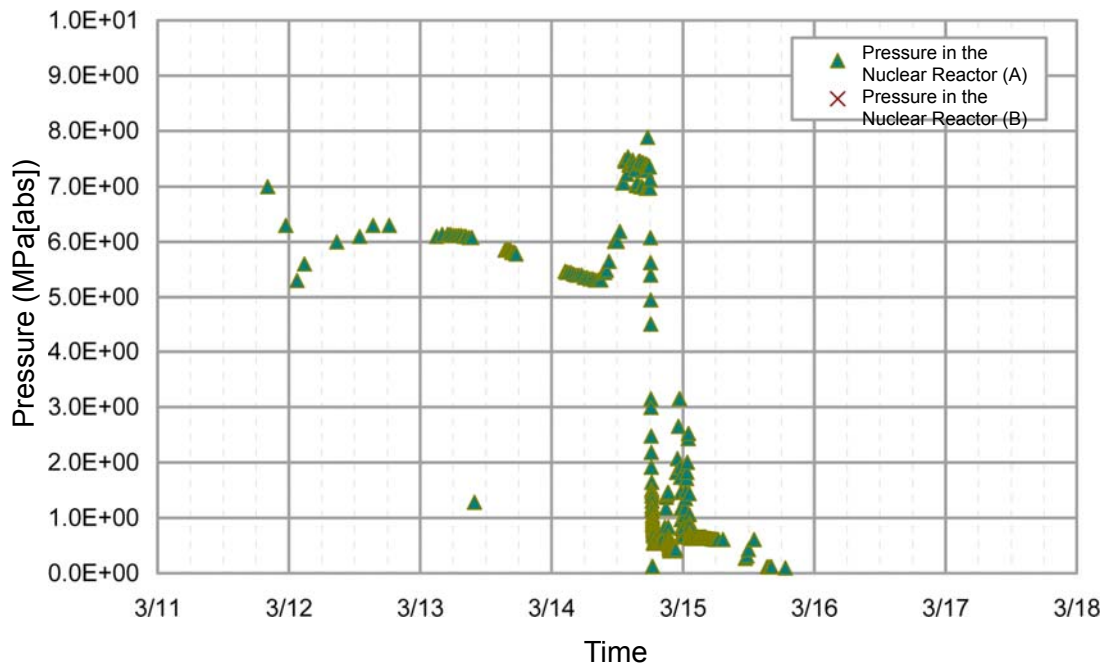

Fig. 2.3-2b: Shift of Pressure in the Nuclear Reactor (Unit 2)

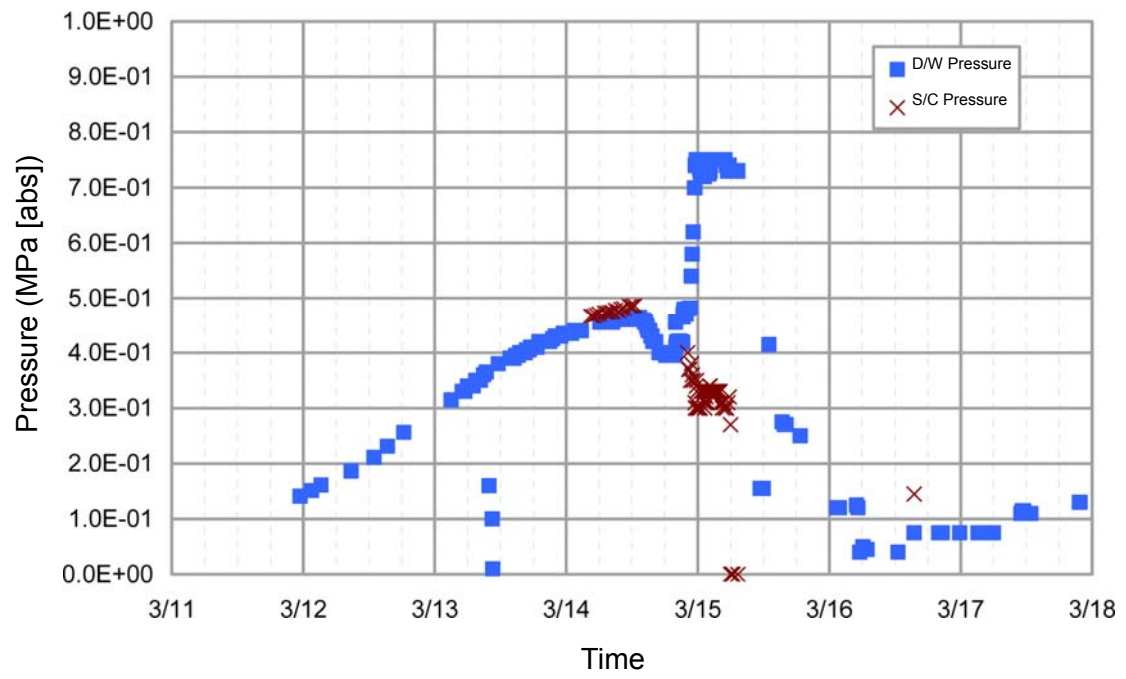

Fig. 2.3-2c: Shift of the Pressure in the Primary Containment Vessel (Unit 2)

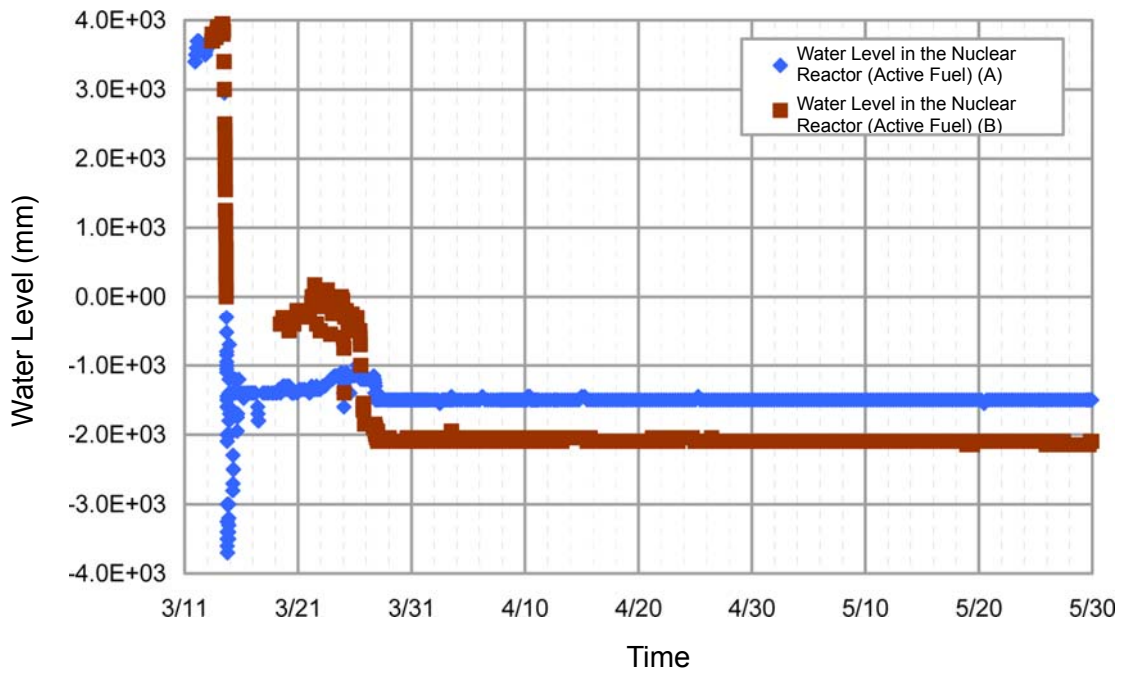

Fig. 2.3-3a: Shift of the Water Level in the Nuclear Reactor (Unit 2: Long Term)

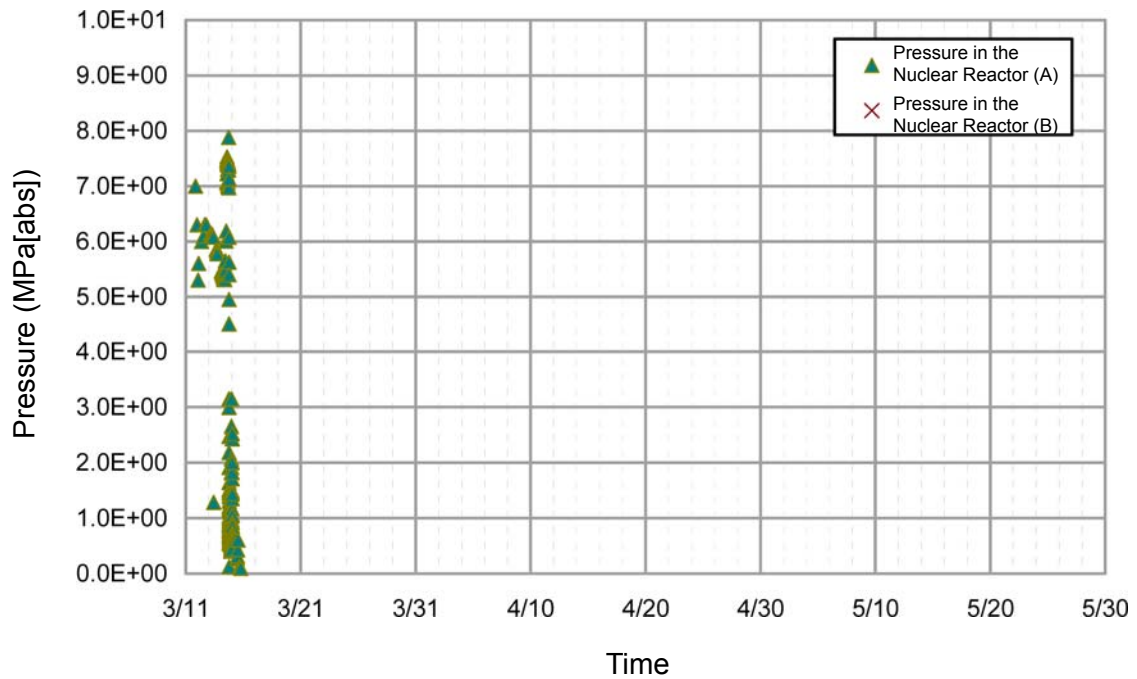

Fig. 2.3-3b: Shift of Pressure in the Nuclear Reactor (Unit 2: Long Term)

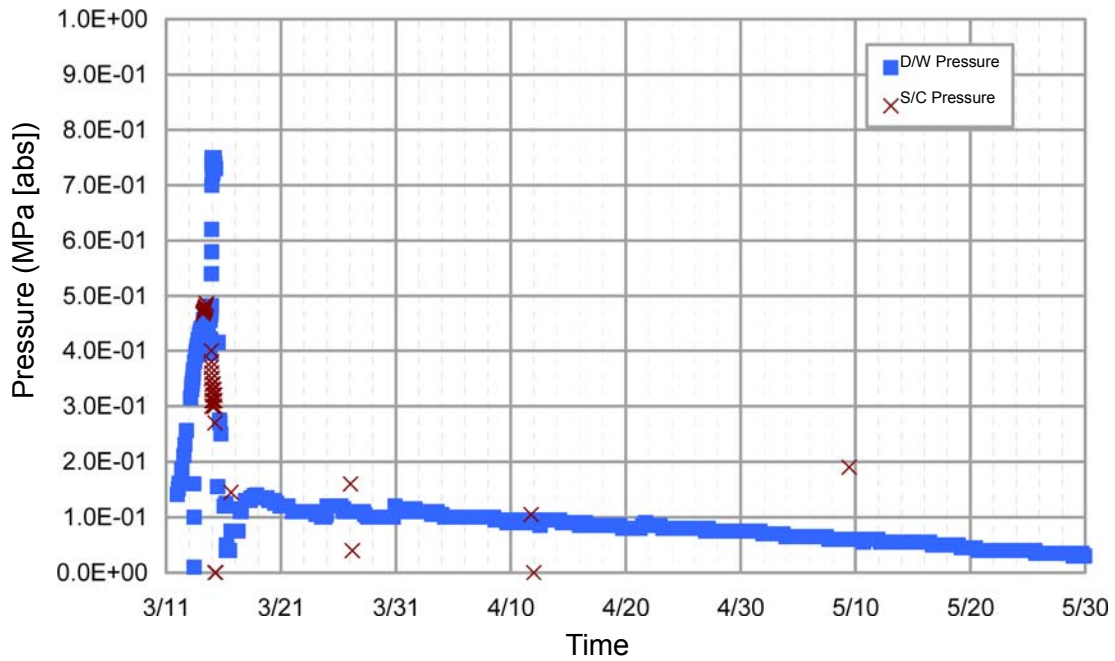

Fig. 2.3-3c: Shift of the Pressure in the Primary Containment Vessel (Unit 2: Long Term)

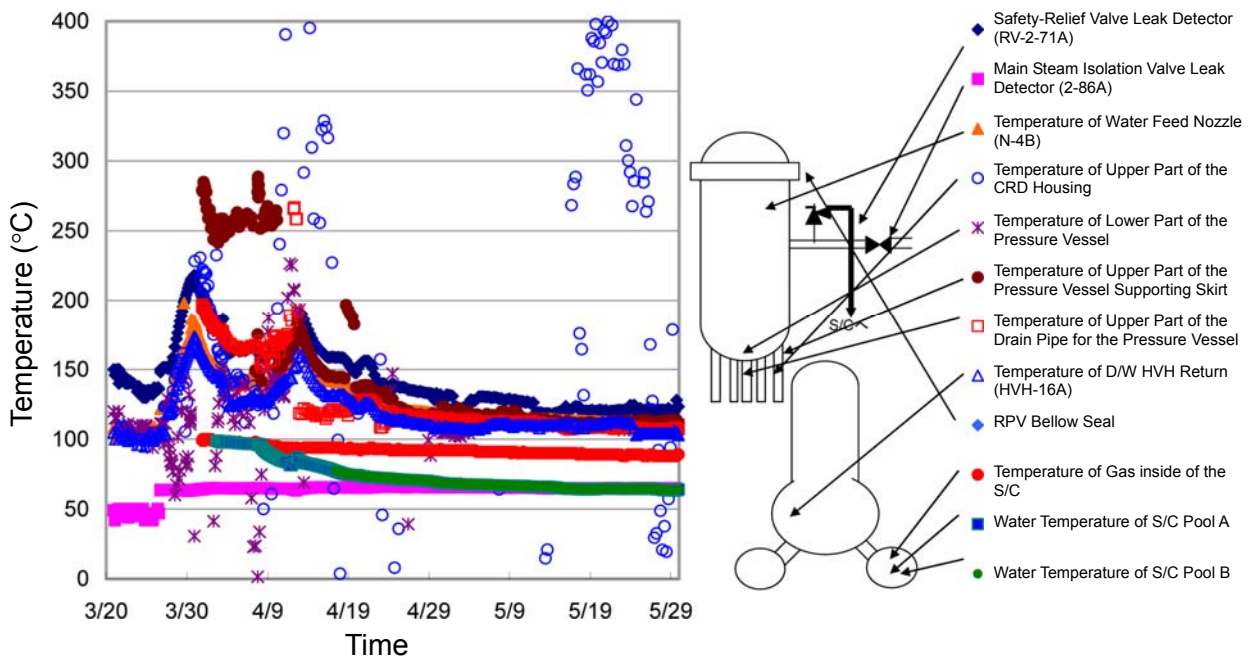

Fig. 2.3-4c: Shift of Temperature (Unit 2: Long Term)

2.4 Course of accident at Unit 3

2.4.1 From occurrence of earthquake to arrival of tsunami

Unit 3 was in constant thermal output operation at 2,381 WMt. Due to the earthquake, it automatically stalled at 14:47 on March 11 after receiving a 'large seismic acceleration' signal and all control rods were fully inserted into the reactor.

The earthquake damaged various systems including equipment in the New Fukushima Substation, causing power supply through Okuma No. 4 Line (Okuma No. 3 Line had been under construction and not used) to be lost. This resulted in total loss of external power supply to the Station. At 14:48, the power supply to the emergency bus conductors was lost. Two DGs for emergency use (3A and 3B) started operating immediately and automatically, and power supply to the emergency bus conductors was restored.

Loss of power supply to the emergency bus conductors caused loss of power supply for the nuclear reactor protection system, which resulted in automatic closure of MSIV. This surged pressure in the nuclear reactor, but the main steam relief valve (SRV) controlled the pressure.

The water level in the nuclear reactor was once lowered immediately after the nuclear reactor stopped automatically, due to a void collapse. However, after that the level was successfully controlled by RCIC without reaching the level that HPCI automatically starts (L-2: TAF+2,950 mm). The nuclear reactor remained stopped automatically after receiving the 'High Nuclear Reactor Water Level' signal at 15:25 on March 11.

As mentioned above, from the time the earthquake occurred to the arrival of the tsunami, the measures taken by the Station were those normally done when the external power supply is lost and there is a scram of a nuclear reactor.

2.4.2 From arrival of tsunami to hydrogen explosion of the reactor building

The first tsunami arrived in about 41 minutes after the earthquake hit the area, i.e., 15:27 on March 11, followed by the second tsunami at 15:35. This caused inundation and submergion of the seawater pump for cooling and power supply panel. At 15:38 on the same day, both emergency DGs (3A and 3B) stopped and AC power supply was totally lost. Due to the Station Black Out, the RHR and the CS were unable to function. The Station determined at 15:42 on March 11 that the situation corresponded to an event applicable to Article 10 of the Act on Special Law of Emergency Preparedness for Nuclear Disaster, i.e., Station Black Out.

Due to the Station Black Out, only emergency lighting systems were available in MCR. The ventilation system in MCR also stopped. Unit 4, located next to Unit 3, was undergoing a regular inspection and all fuel rods were taken out of it. So, parameters such as water level in the nuclear reactor were checked centered on Unit 3, using a flashlight.

The DC power supply system in Unit 3 survived the inundation, and RCIC and the HPCI could be operated by DC power supply. To use the batteries as long as possible, all loads that were not immediately required were disconnected from them.

The RCIC was not in operation, then. As the water level in the nuclear reactor gradually decreased, it was manually run at 16:03 on March 11, to maintain the water level while monitoring the operation of the RCIC.

By 21:58 on the same day, a small power generator was installed in MCR and the temporary lighting system was restored.

From then, the water level in the nuclear reactor was maintained using RCIC. However, at 11:36 on March 12, the RCIC automatically stopped and the water level started falling again. It reached the low nuclear reactor water level (L-2: TAF+2,950 mm) at 12:35 on the same day. This automatically started HPCI.

This restored the water level in the nuclear reactor, which was maintained for a while thanks to the HPCI. At 2:42 on March 13, however, the HPCI automatically stopped, losing its water injection function to the nuclear reactor.

To reverse the situation, D/D-FP, an alternative water injection method for a severe accident was used, but in vain because the pressure inside the nuclear reactor surged to approximately 4.1 MPa [gage].

The workers tried to restart the HPCI and the RCIC, but failed to do so because the battery ran out. So the Station determined at 5:10 on March 13 that the situation corresponded to an event applicable to Article 15 of the Act on Special Law of Emergency Preparedness for Nuclear Disaster, i.e., loss of capacity to cool down a nuclear reactor.

The following explain how the alternative cooling water supply was used and how PCV ventilation was made.

Alternative Cooling Water Supply

The disaster countermeasures office in the Fukushima Daiichi Nuclear Power Station was examining the use of fire engine as an alternative way of injecting water into the nuclear reactor. Of the three fire engines held by the Station, one had already been used for injecting seawater into Unit 1, and the second one was unusable because of the tsunami. The remaining one, mobilized at the Unit 5 to 6 side was unable to be moved because the earthquake damaged the road and the tsunami left a lot of debris. So the roads in the Station's premises were restored urgently and the remaining third fire engine was successfully moved to the Unit 1 to 4 side.

Another fire engine was brought in from the Fukushima Daini Nuclear Power Station and an alternative system to inject water into the nuclear reactor using RHR from FP was constructed with the pumper as the driving source and a water tank for fire-protection (freshwater) as the water source.

In order to use the alternative water injection method, it was necessary to reduce the pressure inside the nuclear reactor so that it was lower than the output pressure of the pumper. For this purpose, batteries had to be collected to manually open the SRV, but all batteries in the Station had already been used for other purposes including restoration of measuring instruments of Units 1 and 2. So car batteries were collected from the cars of the plant workers that had been parked on high ground and thus survived the tsunami, to use them as the power source for the SRV.

The SRV was manually opened at 9:08 on March 13 and the pressure inside the nuclear reactor was rapidly reduced.

After the pressure in the nuclear reactor was reduced, the workers were able to inject water using the pumper. At 9:25 on the same day, the workers started to inject water into the reactor after dissolving boric acid in the freshwater in the water tank for fire-protection.

At 10:30 on the same day, the plant manager indicated he would consider using seawater as an alternative water source.

The water tank for fire-protection became empty at 12:20 on the same day. So, the workers altered the water injection system so that they could use seawater in the backwash valve pit. Use of seawater started at 13:12 on the same day.

In order to replenish seawater in the backwash valve pit, the Station requested to have some more fire engines. However, it took a long time before they arrived at the Station, partly because of the high radiation and contamination in the Station and partly because of the bad road conditions leading to the Station. For these reasons, the fire engines were unable to go directly to the Station but had to be handed over to the plant workers at such places as the Off Site Center and J-Village, and the people there then brought them to the Station. As the seawater in the backwash valve pit was about to run out, the pumper connected to the FP stopped once and was moved closer to the backwash valve pit at 1:10 on March 14. Then, after inserting the hose deeper into the pit, the workers started injecting seawater again at 3:20 on the same day.

The requested fire engines arrived at the Station early in the morning of March 14. The two fire engines were parked around the cargo unloading station to directly suck seawater from the sea and carry it to the backwash valve pit. Replenishment of seawater to the backwash valve pit from the cargo unloading station using the seawater sucking line started at 9:20 on the same day.

A total of 7 water trucks (each 5t) owned by the Self-Defense Forces arrived at the Station. They were set up at the backwash valve pit and the seawater started being replenished at 10:53 on the same day.

An explosion occurred at the R/B of Unit 3 at 11:01 on March 14, possibly a hydrogen gas explosion, which severely damaged the R/B and debris was scattered around the area.

The explosion damaged the fire engines and hoses used for injecting water to the nuclear reactor, and seawater injection stopped. The backwash valve pit became unusable due to the debris and seawater replenishment by the water trucks also stopped.

PCV Ventilation

After the plant manager instructed the workers to start preparing for PCV ventilation at 17:30 on March 12, procedures for the PCV ventilation were examined and locations of valves to be operated were confirmed.

At around 4:50 on March 13, in order to open the AO valve (large valve) on the ventilation line connected from the S/C, the solenoid valve of the AO valve was forcibly energized using a power source supplied by a small-sized power generator for temporary lighting in the central operating room.

At 5:15 on the same day, the plant manager instructed the workers to construct a PCV ventilation system, excluding a rupture disc. A worker checked the opening angle of the AO valve (large valve) in the torus room and found it was closed. So air cylinders supplying force to open and close the valve were replaced with new ones. As a result, the valve opened at 5:23 on March 23.

A press meeting was held to announce of starting a PCV ventilation at 5:50 on March 13 and results of radiation exposure evaluation to the areas neighboring the Station were notified to the relevant organizations at 7:35.

At 7:39 on the same day, the workers started spraying water to the PCVs using the line structure normally used when a severe accident has occurred, using D/D-FP, which was an alternative method of water injection.

Another MO valve on the PCV ventilation line was opened 15% manually on site, using the method stipulated in the procedure document at around 8:35 on the same day. At 8:41, a structure for PCV ventilation was completed, excluding rupture discs. At this point, however, the D/W pressure was lower than the working pressure of a rupture disc, i.e., 427 kPa [gage], and the workers continued monitoring the D/W pressure while keeping the valves on the PCV ventilation line open.

The D/W pressure kept increasing, thereafter. However, it started decreasing (from 0.637 MPa [abs] at 9:10 to 0.540 MPa [abs] at 9:24). So the Station determined that the PCV ventilation was done.

The pressure of cylinders installed at the AO valve (large valve) on the ventilation line connecting from S/C showed a decrease at around 9:28 on March 13. An investigation revealed that a leakage was found at the joints of the cylinders and the joints were additionally tightened. At 11:17 on the same day, the cylinder pressure fell causing the AO valve (large valve) to close. So the cylinders were replaced with new ones and the AO valve (large valve) was opened again at 12:30 on the same day. The workers were unable to perform work to keep the valve open because the conditions at the site were unfavorable.

At 14:15 on the same day, the MP indicated 905 $\mu\text{Sv/h}$ and the Station determined the situation corresponded to an event applicable to Article 15 of the Act on Special Law of Emergency Preparedness for Nuclear Disaster, i.e., abnormal surge of radiation dose at the boundary of the premise.

At around 14:31 on March 13, the radiation dose increased by more than 300 mSv/h at the north of the R/B double doors, and by 100 mSv/h at its southern side and inside the R/B filled with white smoke.

In the central operating room of Unit 3, the radiation dose showed an increase of 12 mSv/h at 15:28 on the same day, so the shift supervisor evacuated the workers to the central operating room on the Unit 4 side.

As the IA, the driving source of the AO valve (large valve) on the ventilation line from S/C was not in operation, the restoration team of the Station's disaster countermeasures office installed a tentative compressor at the service entrance for large items of the T/B and connected it to the IA system at around 17:52 on the same day.

The D/W pressure fell at around 20:10 on the same day, and the Station determined that the AO valve (large valve) was open and the PCV ventilation was done.

The D/W pressure showed an upward trend at around 2:00 on March 14 (from 0.265 MPa [abs] at 2:00 to 0.315 MPa [abs] at 3:00 on March 14) and the Station decided to open another AO valve (small valve) on the ventilation line from S/C. At 3:40 on the same day, an operation to open the AO valve started by forcibly energizing the solenoid valve. The AO valve became open at 6:10.

The radiation dose at the MP recorded 518.7 $\mu\text{Sv/h}$ at 9:12 on March 14 and the Station determined the situation corresponded to an event applicable to Article 15 of the Act on Special Law of Emergency Preparedness for Nuclear Disaster, i.e., abnormal surge of radiation dose at the boundary of the premise.

2.4.3 After hydrogen gas explosion in the R/B

An explosion, possibly of hydrogen gas, occurred at the R/B at 11:01 on March 14. It severely damaged the reactor building. All workers excluding workers at the central operating room stopped all their work and evacuated to the antiseismic building. All restoration work was suspended for a while to check the safety of workers, on-site condition and the safety of the site.

Due to debris generated by the explosion, the backwash valve pit was unable to be used. Fire engines were moved to the area around the cargo unloading station and hoses were relaid to take seawater directly from the sea to inject water to the nuclear reactor. Additionally, two fire engines were connected serially, to form a water feeding system to both Unit 2 and Unit 3. Seawater injection restarted at around 16:30 on March 14.

On the other hand, for the PCV ventilation, it was difficult to energize the solenoid valves on the air feed line while maintaining air pressure to drive the AO valve to keep the AO valves on the ventilation line (small and large valves). An AO valve, even if it was opened, closed instantly. So, for a while the workers repeated an operation to open the valves a number of times.

AO Valve (large valve)

Mar. 15 at 16:00: Closing confirmed	→	Mar. 15 at 16:05: Opening operation
Mar. 17 at 21:00: Closing confirmed	→	Mar. 17 at around 21:30: Opening operation
Mar. 18 at 5:30: Closing confirmed	→	Mar. 18 at around 5:30: Opening operation
Mar. 19 at 11:30: Closing confirmed	→	Mar. 20 at around 11:25: Opening operation

AO Valve (small valve)

Mar. 15 at 16:00: Closing confirmed	→	Mar. 16 at 1:55: Opening operation
-------------------------------------	---	------------------------------------

2.4.4 Major events thereafter

To restore power supply to the Station, the workers repaired the transformers in the New Fukushima Substation and performed bypassing work between the Yonomori Line 1 and the Okuma Line 3. On March 18, recharging was

completed up to the portable M/C installed in the plant premises. Lighting in the central operating room was restored on March 22.

To build an alternative water injection to the nuclear reactor, the workers switched the water source to freshwater supplied from deionized water tanks on March 25. The water source was further changed to a temporary electric motor pump driven by fire engines on March 28. From April 3 onward, the power source to the temporary electric motor pump was switched from a temporary power source to regular power lines.

2.4.5 Condition of spent fuel pool

As of March 11, 514 spent fuel rods and 58 new fuel rods were stored in the spent fuel pool (SFP) of Unit 3. The Station estimated the decay heat generated by these fuel rods in the SFP was approximately 0.54 MWt (as of March 11).

The earthquake that occurred at 14:46 on March 11 caused a total loss of external power supply to the plant, and the FPC came to a halt. The massive tsunami that hit the plant after the earthquake caused Station Blackout and the functions of cooling and supplying water to the SFP were lost.

The explosion of the R/B of Unit 3 that occurred at 11:01 on March 14 caused a massive amount of debris on the SFP.

Seawater was dropped on the R/B using helicopters at around 9:48 on March 17 and generation of steam from the R/B was confirmed. The workers shot water from water canon trucks starting from 19:05 on the same day. They repeated the water shooting till March 25 using water canon trucks and tower water canon vehicles (in most cases using seawater).

From March 27 onward, they used concrete pump trucks for water shooting. The type of water was switched from seawater to freshwater on March 29.

The Station considers that these water injections were successful in keeping the water level in the SFP sufficiently high to prevent the fuel rods from being exposed to the air.

Table 2.4-1 Time-Course Progress (Unit 3)

March 11, 2011 (Fri.)	
14:46	Great East Japan Earthquake occurs. Alert Level 3 automatically issued.
14:47	Scram of nuclear reactors occurs automatically and main turbine manually stops.
Around 14:48	Emergency DG automatically activated.
14:54	Subcriticality of the nuclear reactor confirmed.
15:05	RCIC manually started.
15:06	A disaster countermeasures office established in the TEPCO head office. (to understand the damage conditions due to the earthquake and restoration from blackout)
15:25	RCIC trips (due to high water level in the nuclear reactor).
15:27	First tsunami arrives.
15:35	Second tsunami arrives.
15:38	Station Blackout occurs.
15:42	The Station determined the situation corresponds to a special event applicable to Paragraph 1, Article 10 of the Act on Special Law of Emergency Preparedness for Nuclear Disaster (Station Blackout). Notified the same to governmental agencies and other relevant organizations.
15:42	Alert Level 1 issued. An emergency task force established (as joint headquarters with disaster countermeasures office).
16:03	RCIC manually started.
16:36	Alert Level 2 issued.
20:50	Fukushima Prefecture directs local residents living within a 2 km radius from the Fukushima Daiichi Nuclear Power Station to evacuate.
21:23	The Prime Minister directs local residents living within a 3 km radius from the power plant to evacuate and those living within a 3 km to 10 km radius to stay indoors.
21:58	Temporary lighting in MCR turns ON.
March 12, 2011 (Sat.)	
0:30	Completion of evacuation of the local residents confirmed by the Government of Japan (confirmed evacuation of people living within 3 km from the plant in Futaba City and Okuma City, and reconfirmed it at 1:45).
4:55	Confirmed surge of radiation dose within the plant premises surges (around the main gate: 0.069 μ Sv/h (at 4:00) \rightarrow 0.59 μ Sv/h (at 4:23)). The same is notified to governmental agencies and other relevant organizations.
5:44	The Prime Minister directs local residents living within a 10 km radius from Fukushima Daiichi Nuclear Power Station to evacuate.
7:11	The Prime Minister arrives at the Fukushima Daiichi Nuclear Power Station.
8:04	The Prime Minister leaves the Fukushima Daiichi Nuclear Power Station.
11:36	RCIC trips.
12:35	HPCI automatically runs (due to low water level in the nuclear reactor)
17:30	The plant manager instructs the workers to start preparing for PCV ventilation.
18:25	The Prime Minister directs local residents living within a 20 km radius from the Fukushima Daiichi Nuclear Power Station to evacuate.

March 13, 2011 (Sun.)

- 2:42 HPCI stops.
- 5:10 Water injection using RCIC is failed so the Station determines that a special event applicable to Paragraph 1, Article 15 of the Act on Special Law of Emergency Preparedness for Nuclear Disaster has occurred (nuclear reactor cooling function lost). The same is notified to governmental agencies and other relevant organizations at 5:58.
- 5:15 The plant manager instructs the workers to complete the ventilation line up excluding a rupture disc.
- 5:50 Held a press meeting on initiation of PCV ventilation.
- 6:19 Determined at 4:15 as TAF has been reached. The same is notified to governmental agencies and other relevant organizations.
- 7:35 Notified governmental agencies and other relevant organizations of the result of radiation exposure evaluation to be released when PCV ventilation is done.
- 7:39 Started spraying PCVs. The same is notified to governmental agencies and other relevant organizations at 7:56.
- 8:35 Ventilation valves (MO valves) of PCVs opened.
- 8:41 After opening the large valve of the S/C ventilation valves (AO valves), the ventilation line is completed, excluding a rupture disc. The same is notified to governmental agencies and other relevant organizations at 8:46.
- 8:56 A radiation dose of over 500 $\mu\text{Sv/h}$ at the MP i.e., 882 $\mu\text{Sv/h}$ observed and the Station determines that a special event applicable to Paragraph 1, Article 15 of the Act on Special Law of Emergency Preparedness for Nuclear Disaster has occurred (abnormal surge of radiation dose at the boundary of the premises). The same is notified to governmental agencies and other relevant organizations at 9:01.
- Around 9:08 Safety-relief valves used for rapid release of pressure in the nuclear reactor. Notified the governmental agencies and other relevant organizations at 9:20 that from then onward water would be injected into the nuclear reactor using the FP line.
- 9:25 Started fresh water injection (with boric acid) from the FP line to the nuclear reactor using fire engines.
- 9:36 The ventilation operation confirms that the D/W pressure is being decreased from around 9:20. The Station notifies the governmental agencies and other relevant organizations that it has started injecting water into the nuclear reactor using the FP line.
- 10:30 The plant manager announces that the Station may use seawater injection as an option.
- 11:00 The Prime Minister directs local residents living within a 20 km to 30 km radius from the Fukushima Daiichi Nuclear Power Station to stay indoors.
- 11:17 Confirmed a large valve of the S/C ventilation valve (AO valve) is closed (due to a decreased working air cylinder pressure).
- 12:20 Completed freshwater injection.
- 12:30 A large valve of the S/C ventilation valve (AO valve) opens. (Replaced the working air cylinders.)
- 13:12 Seawater injection to the nuclear reactor starts from the FP line using fire engines.
- 14:15 A radiation dose of over 500 $\mu\text{Sv/h}$ at the MP i.e., 905 $\mu\text{Sv/h}$ observed

and the Station determines that a special event applicable to Paragraph 1, Article 15 of the Act on Special Law of Emergency Preparedness for Nuclear Disaster has occurred (abnormal surge of radiation dose at the boundary of the premises). The same is notified to governmental agencies and other relevant organizations at 14:23.

March 14, 2011 (Mon.)

- 1:10 Seawater in the pit to feed to the nuclear reactor is running out. Stopped the fire engines for replenishing seawater into the backwash valve pit.
- 2:20 A radiation dose of over 500 $\mu\text{Sv/h}$ at around the main gate i.e., 751 $\mu\text{Sv/h}$ observed and the Station determines that a special event applicable to Paragraph 1, Article 15 of the Act on Special Law of Emergency Preparedness for Nuclear Disaster has occurred (abnormal surge of radiation dose at the boundary of the premises). The same is notified to governmental agencies and other relevant organizations at 4:24.
- 2:40 A radiation dose of over 500 $\mu\text{Sv/h}$ at the MP i.e., 650 $\mu\text{Sv/h}$ observed and the Station determines that a special event applicable to Paragraph 1, Article 15 of the Act on Special Law of Emergency Preparedness for Nuclear Disaster has occurred (abnormal surge of radiation dose at the boundary of the premises). The same is notified to governmental agencies and other relevant organizations at 5:37.
- 3:20 Seawater injection using the fire engines resumes.
- 4:00 A radiation dose of over 500 $\mu\text{Sv/h}$ at the MP i.e., 820 $\mu\text{Sv/h}$ observed and the Station determines that a special event applicable to Paragraph 1, Article 15 of the Act on Special Law of Emergency Preparedness for Nuclear Disaster has occurred (abnormal surge of radiation dose at the boundary of the premises). The same is notified to governmental agencies and other relevant organizations at 8:00.
- 5:20 Starts opening operation of a small valve of the S/C ventilation valve (AO valve).
- 6:10 Confirmed that the S/C ventilation valve (AO valve) is open.
- 9:12 A radiation dose of over 500 $\mu\text{Sv/h}$ at the MP i.e., 518.7 $\mu\text{Sv/h}$ observed and the Station determines that a special event applicable to Paragraph 1, Article 15 of the Act on Special Law of Emergency Preparedness for Nuclear Disaster has occurred (abnormal surge of radiation dose at the boundary of the premises). The same is notified to governmental agencies and other relevant organizations at 9:34.
- 9:20 Started replenishing seawater from the cargo unloading station to the backwash valve pit.
- 11:01 An explosion occurs in R/B, damaging the fire engines and hoses. Stopped seawater injection.
- Around 16:30 Constructed a new line that feeds seawater from the cargo unloading station to the nuclear reactor. Replaced the damaged fire engines and hoses with new ones.
- 21:35 A monitoring car recorded a radiation dose of over 500 $\mu\text{Sv/h}$ at the MP i.e., 760 $\mu\text{Sv/h}$ and the Station determines that a special event applicable to Paragraph 1, Article 15 of the Act on Special Law of Emergency Preparedness for Nuclear Disaster has occurred (abnormal surge of radiation dose at the boundary of the premises). The same is notified to governmental agencies and other relevant organizations at 22:35.

March 15, 2011 (Tue.)

- 6:50 A radiation dose of over 500 $\mu\text{Sv/h}$ around the main gate i.e., 583.7 $\mu\text{Sv/h}$ observed and the Station determines that a special event applicable to Paragraph 1, Article 15 of the Act on Special Law of Emergency Preparedness for Nuclear Disaster has occurred (abnormal surge of radiation dose at the boundary of the premises). The same is notified to governmental agencies and other relevant organizations at 7:00.
- 7:00 Notified the governmental agencies and other relevant organizations that all workers except for monitoring staff and other workers required for restoration of the Station would evacuate to Fukushima Daini Nuclear Power Station.
- 7:55 Confirmed steam floating above the R/B. The same is notified to governmental agencies and other relevant organizations.
- 8:11 A radiation dose of over 500 $\mu\text{Sv/h}$ around the main gate i.e., 807 $\mu\text{Sv/h}$ observed and the Station determines that a special event applicable to Paragraph 1, Article 15 of the Act on Special Law of Emergency Preparedness for Nuclear Disaster has occurred (abnormal release of radioactive substances due to a fire and an explosion). The same is notified to governmental agencies and other relevant organizations at 8:36.
- 16:00 A radiation dose of over 500 $\mu\text{Sv/h}$ at the main gate i.e., 531.6 $\mu\text{Sv/h}$ observed and the Station determines that a special event applicable to Paragraph 1, Article 15 of the Act on Special Law of Emergency Preparedness for Nuclear Disaster has occurred (abnormal surge of radiation dose at the boundary of the premises). The same is notified to governmental agencies and other relevant organizations at 16:22.
- 23:05 A radiation dose of over 500 $\mu\text{Sv/h}$ around the main gate i.e., 4,548 $\mu\text{Sv/h}$ observed and the Station determines that a special event applicable to Paragraph 1, Article 15 of the Act on Special Law of Emergency Preparedness for Nuclear Disaster has occurred (abnormal release of radioactive substances due to a fire and an explosion). The same is notified to governmental agencies and other relevant organizations at 23:20.

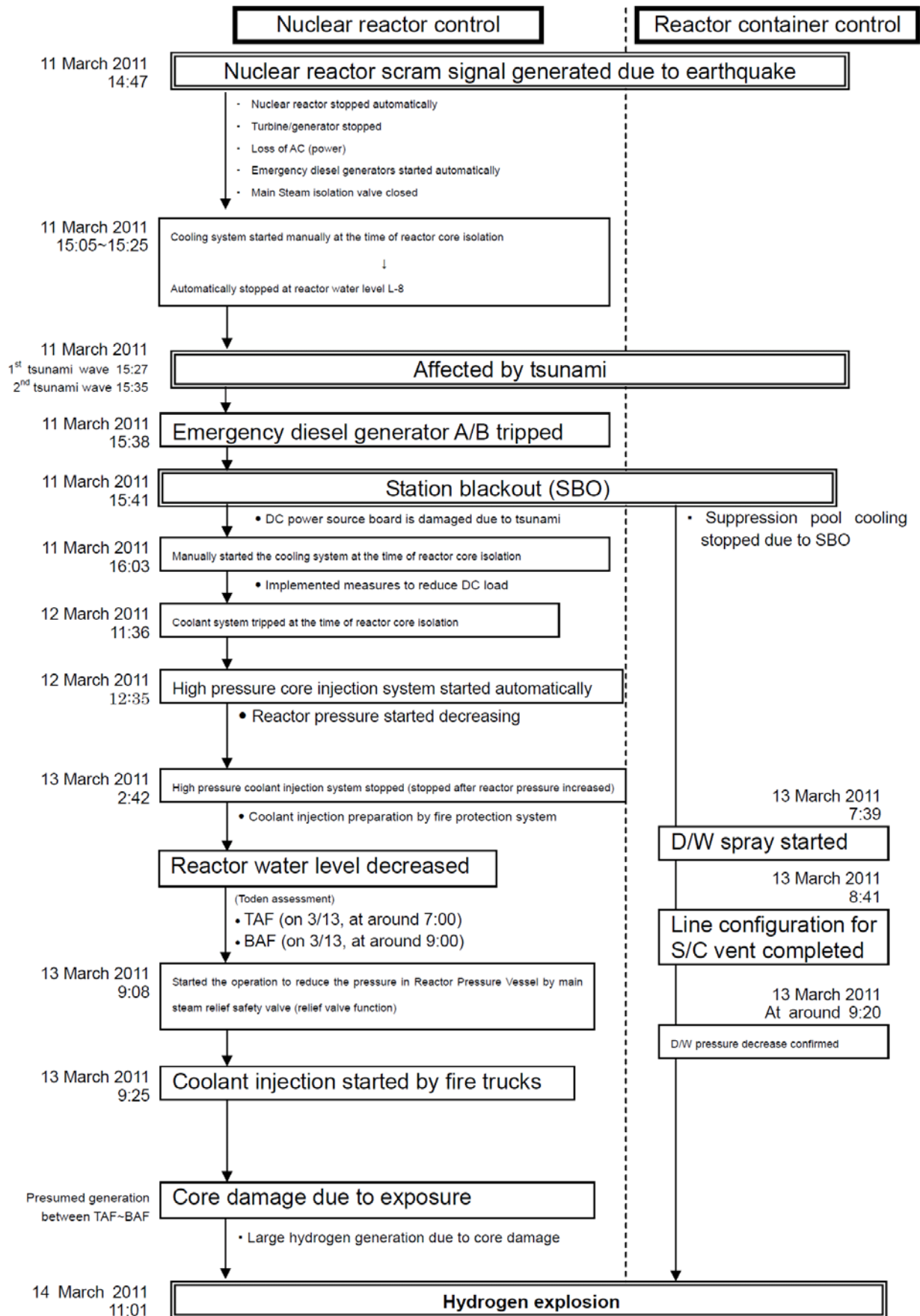

Fig. 2.4-1: Fukushima Daiichi Nuclear Power Station Unit 3 accident progress flow after the earthquake

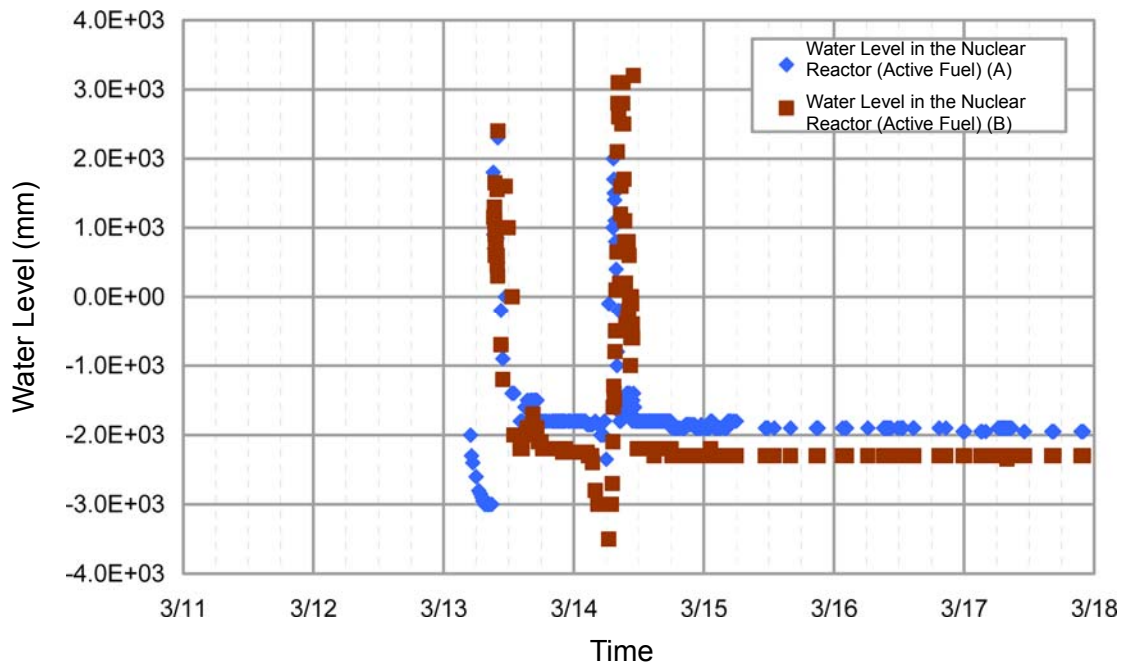

Fig. 2.4-2a: Shift of the Water Level in the Nuclear Reactor (Unit 3)

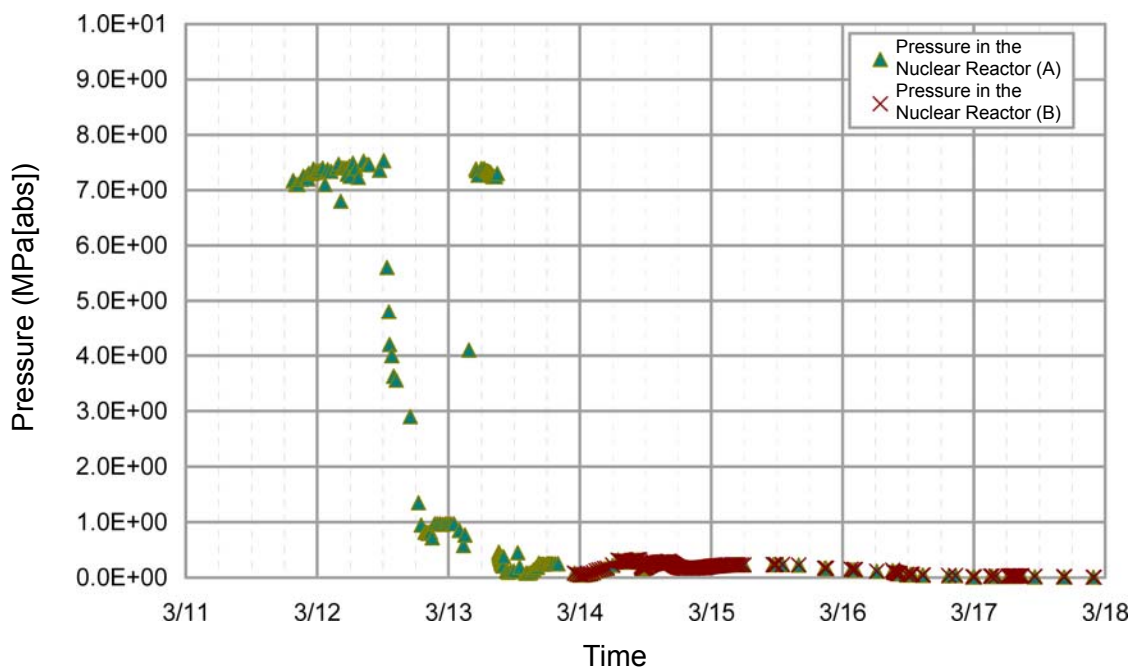

Fig. 2.4-2b: Shift of Pressure in the Nuclear Reactor (Unit 3)

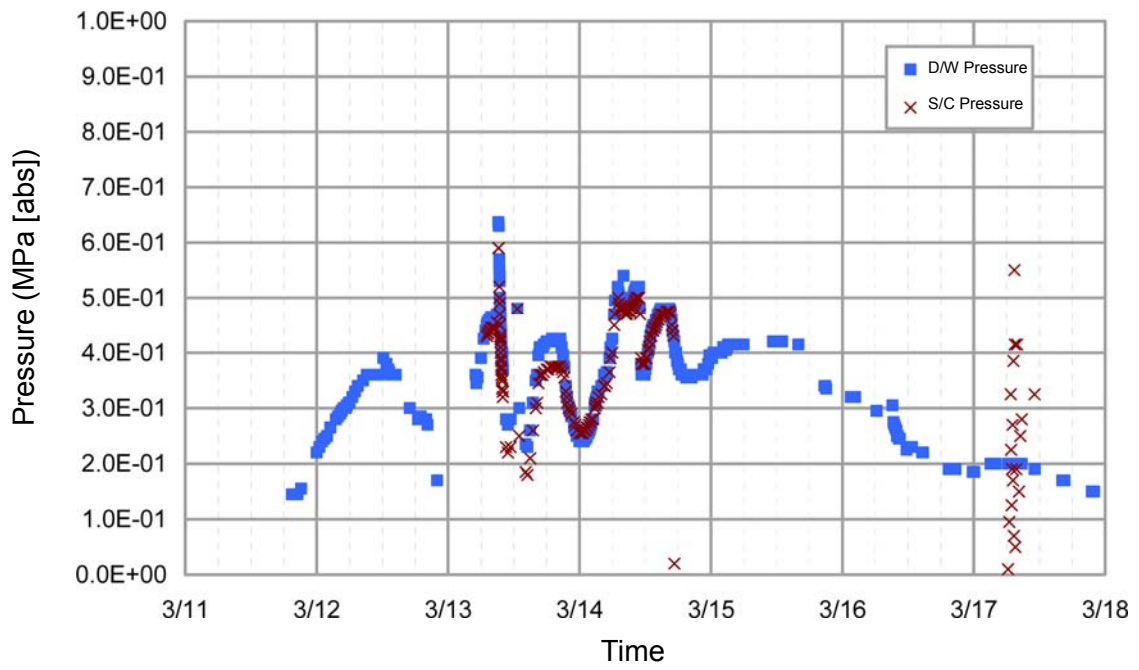

Fig. 2.4-2c: Shift of the Pressure in the Primary Containment Vessel (Unit 3)

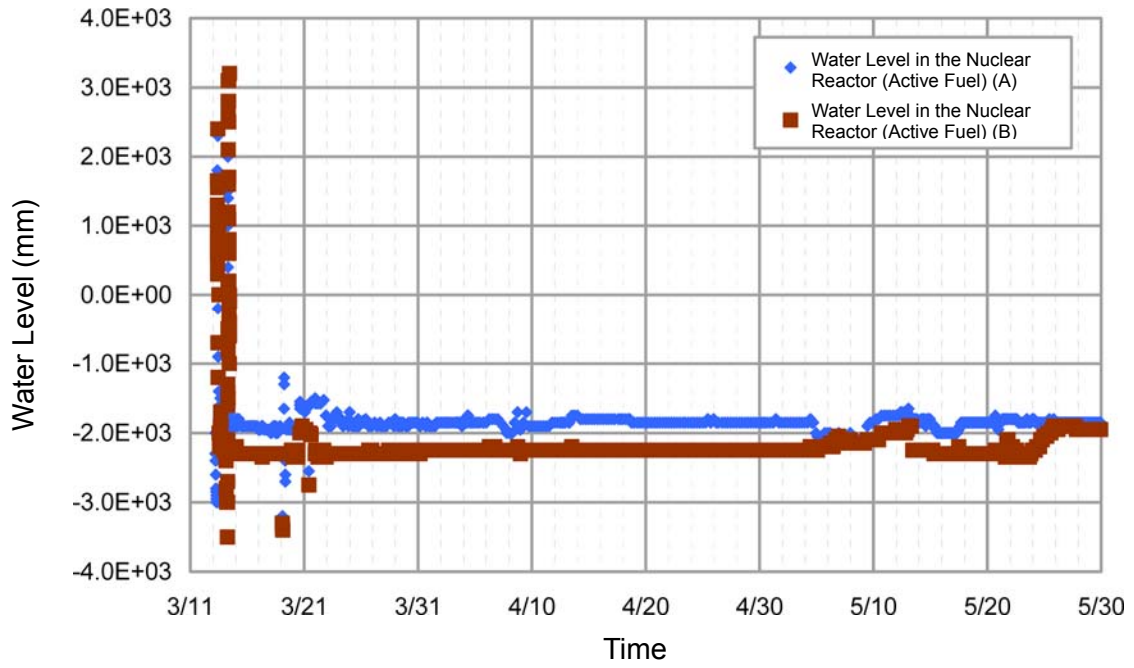

Fig. 2.4-3a: Shift of the Water Level in the Nuclear Reactor (Unit 3: Long Term)

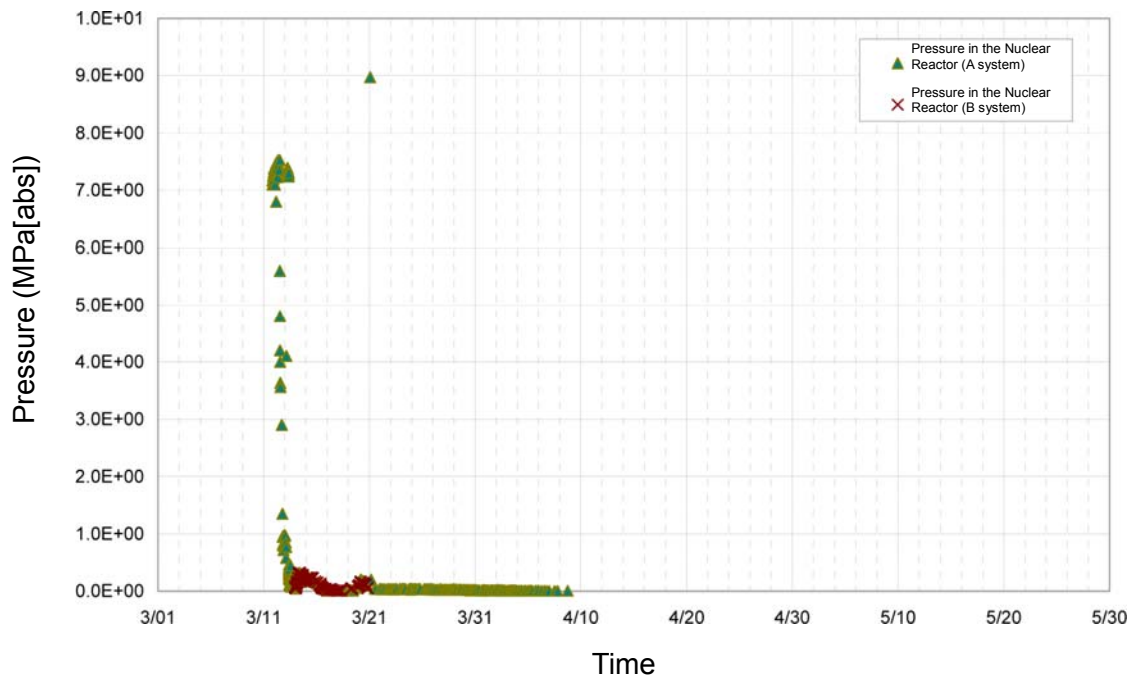

Fig. 2.4-3b: Shift of Pressure in the Nuclear Reactor (Unit 3: Long Term)

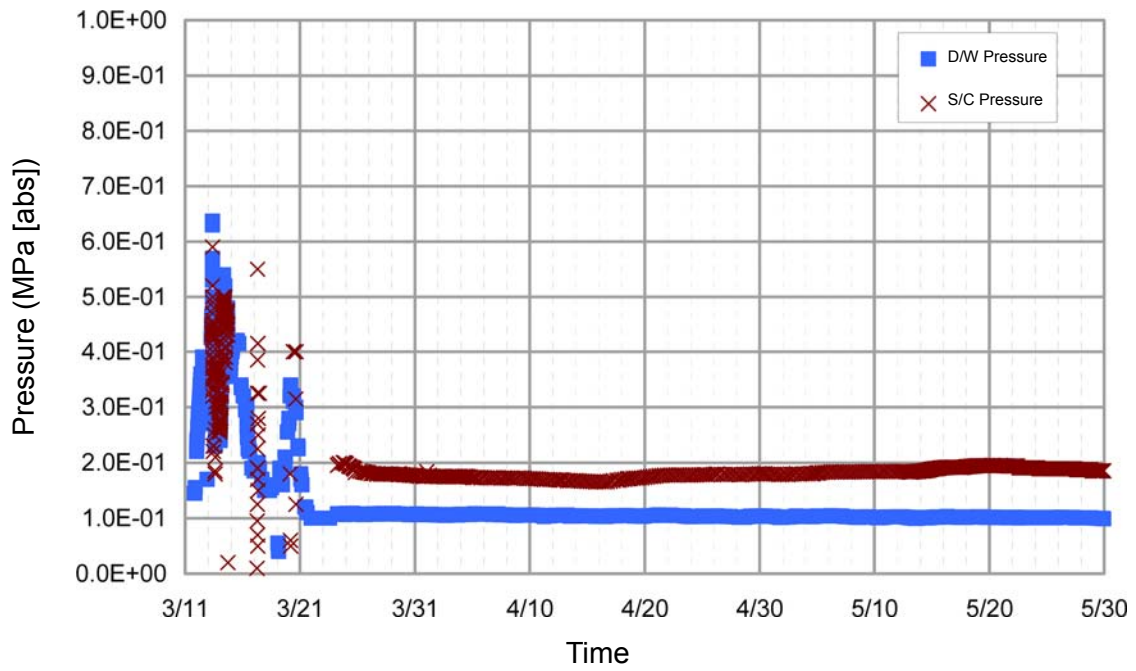

Fig. 2.4-3c: Shift of the Pressure in the Primary Containment Vessel (Unit 3: Long Term)

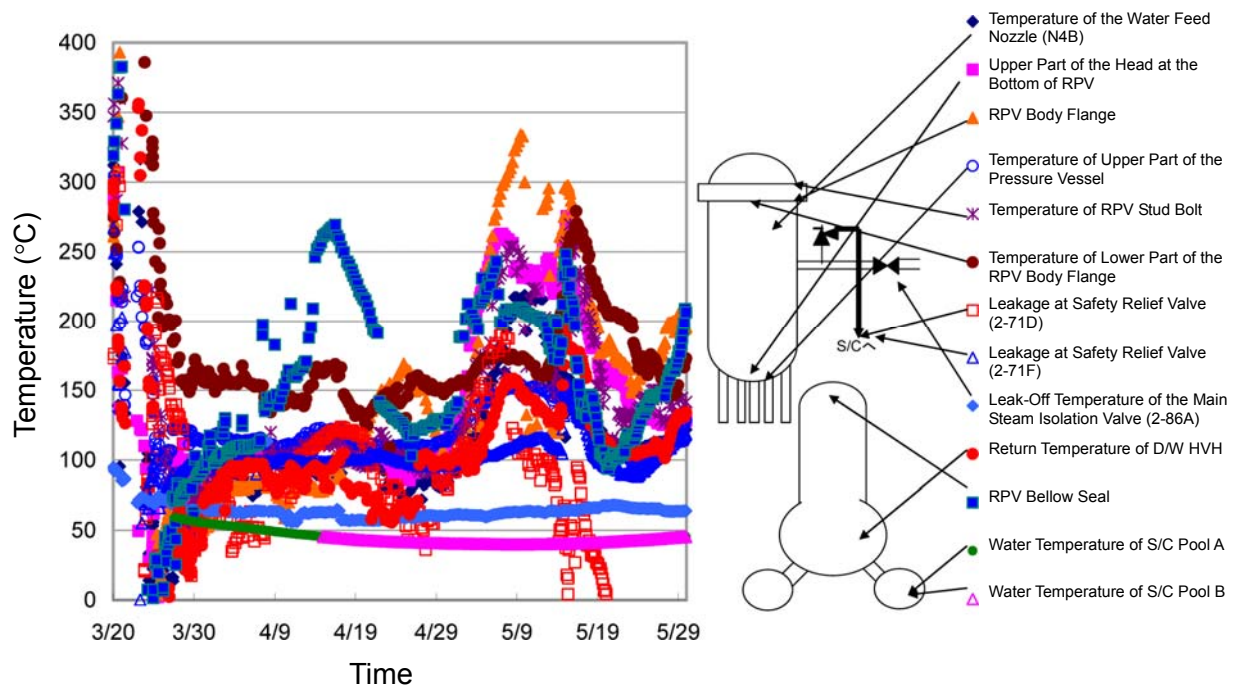

Fig. 2.4-4c: Shift of Temperature (Unit 3: Long Term)

2.5 Course of accident at Unit 4

Unit 4 had been undergoing a regular inspection since November 30, 2010 and all fuel rods had been taken out of the nuclear reactor to its SFP to replace its shroud. A total of 1,535 fuel rods (97% of the total storage capacity) were in the SFP and their decay heat was relatively high (decay heat: approximately 2.26 MWt as of March 11).

The water level in the SFP was around the overflow level and the temperature was approximately 27°C. On the nuclear reactor side, the pool gate was closed and filled with water.

The earthquake that occurred at around 14:47 on March 11 damaged various systems including equipment in the New Fukushima Substation, causing a total loss of external power supply. However, a stand-by emergency DG automatically started (another DG was undergoing a regular inspection) and the necessary power supply to the system was secured.

The massive tsunami that hit the plant at 15:38 on March 11 made the emergency DG stop and a Station Black Out occurred. This made it impossible to cool down the SFP. Temporary lighting equipment only was available in the central operating room.

After restoration work by the restoration team of the Station's disaster countermeasures office, a small-sized power generator was installed in the central operating room and a temporary lighting system became available at 21:58 on the same day.

Then, the water temperature in the SFP reached to 84°C at 4:08 on March 14.

A very loud sound was heard at around 6:00 on March 15. Damage was found to the roof of the 5th Floor of the R/B of Unit 4. In addition, at 9:38 on March 15, a fire was observed around the northwestern corner on the 3rd Floor of the R/B. An on-site investigation started at around 11:00 on the same day, but the fire had already been automatically extinguished.

Workers onboard a helicopter of the Self-Defense Forces made an approach to its operating floor on March 16. They visually noted the water surface of the spent fuel pool and confirmed that fuel rods in it were not exposed.

Water injection by the Self-Defense Forces and by a high-pressure water canon owned by the U.S. forces was carried out on March 20 and March 21 respectively. Another water injection started on March 22 using a concrete pumper.

The workers investigated the R/B, and found that its 5th Floor and western and eastern sides on the 4th Floor were seriously damaged. The Station estimated that hydrogen was present around the 4th and 5th Floors. Water was sampled from the pool. From the fact that only a small amount of radioactive substance was contained in it as well as from the result of observations via underground photography, the Station considered that most fuel rods were intact. Therefore, there was only a small possibility that the fuels in the SFP had heated up and generated hydrogen.

In addition, the Station assumed that the water level in the SFP had been maintained in a way that any fall in the water level due to evaporation was being supplemented by water on the well side poured into the SFP by way of the gate, and this prevented the fuel rods from being exposed.

A pipe for the Standby Gas Treatment System (hereafter called "SGTS") of Unit 4 joins together with that of Unit 3 just before the exhaust pipe. The Station therefore points out that the flow of gas ventilated from Unit 3 might have flowed into Unit 4 through the SGTS pipes.

Table 2.5-1 Time-Course Progress (Unit 4)

March 11, 2011 (Fri.)

- 14:46 Great East Japan Earthquake occurs. Alert Level 3 automatically issued.
- 15:06 A disaster countermeasures office established in the TEPCO head office (to understand damage conditions due to the earthquake and restoration from blackout).
- 15:27 First tsunami arrives.
- 15:35 Second tsunami arrives.
- 15:38 Station Black Out occurs to Unit 4.
- 15:42 The Station determines that a special event applicable to Paragraph 1, Article 10 of the Act on Special Law of Emergency Preparedness for Nuclear Disaster has occurred (Station Black Out) to Unit 1*, Unit 2*, Unit 3*, Unit 4* and Unit 5*. The same is notified to governmental agencies and other relevant organizations.
* Corrected on April 24, 2011. The Station Black Out occurred at Unit 1, 2 and 3 only.
- 15:42 Alert Level 1 issued. An emergency task force established (as joint headquarters with the disaster countermeasures office).
- 16:36 Alert Level 2 issued.
- 20:50 Fukushima Prefecture directs local residents living within a 2 km radius from the Fukushima Daiichi Nuclear Power Station to evacuate.
- 21:23 The Prime Minister directs local residents living within a 3 km radius from the power plant to evacuate and those living within a 3 km to 10 km radius to stay indoors.

March 12, 2011 (Sat.)

- 0:30 Completion of evacuation of the local residents confirmed by the Government of Japan (confirmed evacuation of people living within 3 km from the plant in Futaba City and Okuma City, and reconfirmed it at 1:45).
- 4:55 Development of radiation dose within the plant premises is confirmed. The same is reported to the governmental agencies and other relevant organizations.
- 5:44 The Prime Minister directs local residents living within a 10 km radius from Fukushima Daiichi Nuclear Power Station to evacuate.
- 7:11 The Prime Minister arrives at the Fukushima Daiichi Nuclear Power Station.
- 8:04 The Prime Minister leaves the Fukushima Daiichi Nuclear Power Station.
- 16:27 A radiation dose of over 500 $\mu\text{Sv/h}$ at the MP i.e., 1,015 $\mu\text{Sv/h}$ observed and the Station determines that a special event applicable to Paragraph 1, Article 15 of the Act on Special Law of Emergency Preparedness for Nuclear Disaster has occurred (abnormal surge of radiation dose at the boundary of the premises). The same is notified to governmental agencies and other relevant organizations.
- 18:25 The Prime Minister directs local residents living within a 20 km radius from the Fukushima Daiichi Nuclear Power Station to evacuate.

March 13, 2011 (Sun.)

- 8:56 A radiation dose of over 500 $\mu\text{Sv/h}$ at the MP i.e., 882 $\mu\text{Sv/h}$ observed and the Station determines that a special event applicable to Paragraph 1, Article 15 of the Act on Special Law of Emergency Preparedness for Nuclear Disaster has occurred (abnormal surge of radiation dose at the

boundary of the premises). The same is notified to governmental agencies and other relevant organizations at 9:01.

14:15 A radiation dose of over 500 $\mu\text{Sv/h}$ at the MP i.e., 905 $\mu\text{Sv/h}$ observed and the Station determines that a special event applicable to Paragraph 1, Article 15 of the Act on Special Law of Emergency Preparedness for Nuclear Disaster has occurred (abnormal surge of radiation dose at the boundary of the premises). The same is notified to governmental agencies and other relevant organizations at 14:23.

March 14, 2011 (Mon.)

2:20 A radiation dose of over 500 $\mu\text{Sv/h}$ at around the main gate i.e., 751 $\mu\text{Sv/h}$ observed and the Station determines that a special event applicable to Paragraph 1, Article 15 of the Act on Special Law of Emergency Preparedness for Nuclear Disaster has occurred (abnormal surge of radiation dose at the boundary of the premises). The same is notified to governmental agencies and other relevant organizations at 4:24.

2:40 A radiation dose of over 500 $\mu\text{Sv/h}$ at the MP i.e., 650 $\mu\text{Sv/h}$ observed and the Station determines that a special event applicable to Paragraph 1, Article 15 of the Act on Special Law of Emergency Preparedness for Nuclear Disaster has occurred (abnormal surge of radiation dose at the boundary of the premises). The same is notified to governmental agencies and other relevant organizations at 5:37.

4:00 A radiation dose of over 500 $\mu\text{Sv/h}$ at the MP i.e., 820 $\mu\text{Sv/h}$ observed and the Station determines that a special event applicable to Paragraph 1, Article 15 of the Act on Special Law of Emergency Preparedness for Nuclear Disaster has occurred (abnormal surge of radiation dose at the boundary of the premises). The same is notified to governmental agencies and other relevant organizations at 8:00.

4:08 Temperature in the SFP of Unit 4 is confirmed as 84°C.

9:12 A radiation dose of over 500 $\mu\text{Sv/h}$ at the MP i.e., 518.7 $\mu\text{Sv/h}$ observed and the Station determines that a special event applicable to Paragraph 1, Article 15 of the Act on Special Law of Emergency Preparedness for Nuclear Disaster has occurred (abnormal surge of radiation dose at the boundary of the premises). The same is notified to governmental agencies and other relevant organizations at 9:34.

21:35 A monitoring car recorded radiation dose of over 500 $\mu\text{Sv/h}$ at the MP i.e., 760 $\mu\text{Sv/h}$ and the Station determines that a special event applicable to Paragraph 1, Article 15 of the Act on Special Law of Emergency Preparedness for Nuclear Disaster has occurred (abnormal surge of radiation dose at the boundary of the premises). The same is notified to governmental agencies and other relevant organizations at 22:35.

March 15, 2011 (Tue.)

Around 6:00 to 6:10

A large sound is heard. Damage to around the roof of the 5th Floor of Unit 4 R/B is confirmed.

6:50 A radiation dose of over 500 $\mu\text{Sv/h}$ around the main gate i.e., 583.7 $\mu\text{Sv/h}$ observed and the Station determines that a special event applicable to Paragraph 1, Article 15 of the Act on Special Law of Emergency Preparedness for Nuclear Disaster has occurred (abnormal surge of

radiation dose at the boundary of the premises). The same is notified to the governmental agencies and other relevant organizations at 7:00.

- 7:55 The Station notifies the governmental agencies and other relevant organizations that it has confirmed damage around the roof of the 5th Floor of Unit 4 R/B.
- 8:11 Damage to the Unit 4 R/B is confirmed. A radiation dose of over 500 $\mu\text{Sv/h}$ around the main gate i.e., 807 $\mu\text{Sv/h}$ observed and the Station determines that a special event applicable to Paragraph 1, Article 15 of the Act on Special Law of Emergency Preparedness for Nuclear Disaster has occurred (abnormal release of radioactive substances due to a fire and an explosion). The same is notified to governmental agencies and other relevant organizations at 8:36.
- 9:38 A fire is confirmed around the northwestern corner on the 3rd Floor of the Unit 4 R/B. The same is notified to the governmental agencies and other relevant organizations at 9:56.
- Around 11:00 Workers of TEPCO makes an on-site investigation of the fire that occurred at Unit 4 R/B, but they confirm that the fire has been automatically extinguished. The same is notified to the governmental agencies and other relevant organizations at 11:45.
- 16:00 A radiation dose of over 500 $\mu\text{Sv/h}$ at the main gate i.e., 531.6 $\mu\text{Sv/h}$ observed and the Station determines that a special event applicable to Paragraph 1, Article 15 of the Act on Special Law of Emergency Preparedness for Nuclear Disaster has occurred (abnormal surge of radiation dose at the boundary of the premises). The same is notified to governmental agencies and other relevant organizations at 16:22.
- 23:05 A radiation dose of over 500 $\mu\text{Sv/h}$ around the main gate i.e., 4,548 $\mu\text{Sv/h}$ observed and the Station determines that a special event applicable to Paragraph 1, Article 15 of the Act on Special Law of Emergency Preparedness for Nuclear Disaster has occurred (abnormal release of radioactive substances due to a fire and an explosion). The same is notified to governmental agencies and other relevant organizations at 23:20.

2.6 Course of accident at Unit 5

Unit 5 had been suspended since January 3, 2011 due to a periodic inspection. When the earthquake occurred, the reactor was loaded with fuel, and pressure leak tests of the RPV were being conducted with the control rod fully inserted. (RPV was full of water, and pressure of the nuclear reactor was approximately 7M Pa [gage], and temperature of the nuclear reactor was approximately 90°C). The water level of the SFP was full (around the overflow level), and water temperature of the pool was 24°C.

At 14:47 on March 11, the collapse of the steel towers of Yoronomori transmission line due to the earthquake caused a loss of external power supply, which automatically activated two emergency DGs.

After the earthquake occurred, the CRD pump that had been applying pressure on the reactor for the pressure leak test stopped due to a loss of power supply, leading to a temporary pressure drop in the reactor. In addition, although operation of the spent fuel cooling and filtering system pump also stopped as a result of the loss of power of external power supply, the RHR was put into standby state as the water temperature of the pool was sufficiently low and time was not pressing.

Then, the two emergency DGs stopped at 15:40 on March 11 due to the huge tsunami, resulting in the station blackout. As a result of this, the RHR and CS pumps became inoperable.

In the central operating room on the side of Unit 5 only temporary emergency lighting was available, which then went out. However, some of the monitoring instruments could be checked thanks to the DC power supply even after the Station Blackout.

As the pressure of the reactor increased due to decay heat, the workers attempted to reduce the pressure using the RCIC steam line and such like, but no change occurred. Around 1:40 on March 12, the SRV repeated automatic opening and closing operations by the safety valve function, and the pressure of the reactor was maintained at around 8 MPa [gage]. (The maximum operating pressure was 8.27 MPa [gage]).

At 6:06 on March 12, the workers opened the vent valve on top of the RPV to reduce the pressure of the RPV.

One emergency DG of Unit 6 was operating. Thus, at 8:13 on March 12, the workers utilized the power interchange cable to Unit 5, which had been laid as a countermeasure against severe accidents, and supplied electricity to part of the low voltage power panel of the R/B of Unit 5 from the emergency DG of Unit 6. In this way, they secured a power supply for instruments and such like. At 18:29 on March 13, they laid a temporary cable from the low voltage distribution board of Unit 6 and the MUWC pump was manually started at 20:54 on March 13.

In the early hours of March 14, the SRV was restored so that it could be operated from the central operating room. After 5:00 on March 14, the workers reduced the pressure with the SRV as appropriate, and the pressure of the reactor was maintained at 2 MPa [gage] or lower. In addition, by using the alternative water injection line installed as a countermeasure against severe accidents, the workers started injecting water into the reactor from the CST by the MUWC pump at 5:30

on March 14. From then, they injected water intermittently to adjust the water level of the reactor. At 9:27 on March 14, they also supplied water to the SFP. From March 16 to 17, part of the SFP water was drained to the S/C and supplied by the MUWC pump, and an increase in the water temperature of the SFP was controlled.

On March 17, in order to install a temporary submersible pump the workers removed debris scattered by the tsunami and such like. Then, they prepared a power supply on March 18, and installed a temporary seawater pump for the RHR in the water intake trench, and activated it on March 19. As the high voltage power panel in the basement of T/B could not be used due to flooding, power was supplied to the RHR pump by directly laying a temporary cable from the power panel of Unit 6. Then, the RHR pump was started around 5:00 on March 19, and the SFP began to be cooled.

Then, the Station decided to alternately cool the SFP and reactor by switching the system configuration. The workers started cooling the reactor at 12:25 on March 20. At 14:30 on March 20, the reactor achieved a cold shutdown.

Table 2.6-1 Main Chronology (Unit 5)

March 11, 2011 (Friday)

- 14:46 Great East Japan Earthquake occurred.
- 14:47 The emergency DGs of Unit 5 were automatically activated.
- 15:27 The first tsunami arrived.
- 15:35 The second tsunami arrived.
- 15:40 Total Blackout
- 15:42 The Station determines that for Unit 1*, Unit 2*, Unit 3*, Unit 4*, and Unit 5*, a specific event (Total Blackout) based on Article 10 of the Special Law on Emergency Preparedness for Nuclear Disaster occurred, and the authorities were notified accordingly.
 - * On April 24, 2011, a correction was made to the effect that the specific event had occurred only at Unit 1, Unit 2, and Unit 3.

March 12, 2011 (Saturday)

- 0:09 TEPCO departed for the site at Unit 5 and Unit 6 to inspect the power supply system in the station.
- About 1:40 The SRV was automatically opened. (From then, pressure of the reactor was maintained at approximately 8 MPa through repeated opening and closing.)
- 6:06 The pressure of the RPV was reduced by opening the valve on the top of the RPV.
- 8:13 Electric power interchange to Unit 5 (part of the DC power supply) was enabled by the provided cable from the DG of Unit 6.
- 14:42 With the power supply from the DG, the air conditioning system on the side of Unit 6 of the MCR emergency ventilation and air conditioning system of Unit 5 and 6 was manually started and cleaning of air in the MCR of Unit 5 and 6 was started.

March 13, 2011 (Sunday)

- 18:29 Supply of power by the temporary cable from the DG of Unit 6 to the MUWC started.
- 20:54 The MUWC pump was manually started.
- 20:54 The SGTS was manually started.

March 14, 2011 (Monday)

- 5:00 The SRV was opened and pressure of the RPV was reduced. (From then, the opening operation was conducted intermittently.)
- 5:30 Water injection into the reactor by the MUWC was started. (From then, water was injected intermittently.)
- 9:27 Supply of water to the Spent Fuel Pool was started. (From then, the supply was conducted intermittently.)

March 16, 2011 (Wednesday)

- 22:16 Change of water in the Spent Fuel Pool was started.

March 17, 2011 (Thursday)

- 5:43 Change of water in the Spent Fuel Pool completed.

March 18, 2011 (Friday)

13:30 Workers completed making holes (at three locations) in the roof of the reactor building.

March 19, 2011 (Saturday)

1:55 The RHR temporary seawater pump was activated by the temporary power supply from the power supply vehicle.

4:22 The second DG of Unit 6 was started

About 5:00 The RHR was manually started. (Cooling of the Spent Fuel Pool was started in emergency load mode.)

March 20, 2011 (Sunday)

10:49 The RHR was manually stopped. (Emergency thermal load mode.)

12:25 The RHR was manually started. (Cooling of the reactor was started in stop cooling mode.)

14:30 The water temperature of the reactor fell below 100°C and the reactor achieved a cold shutdown.

2.7 Course of accident at Unit 6

Unit 6 had been suspended since August 14, 2010 due to a periodic inspection. When the earthquake occurred, the reactor was loaded with fuel, and the top lid of the RPV was tightened by bolts. The reactor was in a cold shutdown condition and the control rods were fully inserted. The duty person before the earthquake occurred confirmed that the water level of the SFP was full (around the overflow level), and that water temperature of the pool was 25°C.

At 14:47 on March 11, the collapse of the steel towers of Yoronomori transmission line due to the earthquake caused a loss of external power supply, which automatically activated three emergency DGs. As a result of the loss of external power supply, operation of the RHR and FPC halted. As the reactor had been in a cold shutdown condition before the earthquake, the water temperature of the SFP was sufficiently low and time was not pressing. Thus, the RHR and FPC were put into a standby state.

Then, at 15:36 on March 11, affected by the massive tsunami, two emergency DGs (6A, HPCSDG) lost functionality due to the flooding of the seawater pumps or power panel and such like. However, one emergency DG (6B) continued to operate as it was of an air-cooled type and the power panel was still usable. This enabled a supply of power necessary to allow the Station to supply water into the reactor. The RHR, Low Pressure Core Spray System, and High Pressure Core Spray System (hereafter called "HPCS") became inoperable due to a loss of power or submerged seawater pumps.

The pressure in the reactor moderately increased due to the decay heat after the earthquake occurred; however, the rate of increase was more modest than that of Unit 5 because a longer period of time had elapsed after the halt.

At 13:01 on March 13, the MUWC pump was started, and at 13:20, injection of water into the reactor from the CST was started. After March 14, the SRV was used to reduce pressure as appropriate, and the reactor pressure and water level were controlled.

The workers tried to cool the SFP, but as the seawater pumps were unusable due to the massive tsunami, they stirred the water in the pool several times after March 16 with the FPC pump that was still operable with the one remaining emergency DG.

From March 17, in order to install a temporary submersible pump, the workers conducted debris removal work, prepared a power supply, and did other tasks. They installed a temporary seawater pump for the RHR in the water intake trench and started it on March 19. Then, at 22:14 on March 19, the RHR pump was started and cooling of the SFP was started.

As the soundness of the DG seawater pump (6A) flooded by the tsunami was confirmed on March 18, the same seawater pump was started at 19:07 on March 18, and the emergency DG (6A) was started at 4:22 on March 19.

Then, the Station decided to alternately cool the reactor and SFP by switching the system configuration, and the reactor started to be cooled at 18:46 on March 20. The reactor achieved a cold shutdown at 19:27 on March 20.

Table 2.7-1 Main Chronology (Unit 6)

March 11, 2011 (Friday)

- 14:46 Great East Japan Earthquake occurred.
- 14:47 The three emergency DGs of Unit 6 were automatically activated.
- 15:27 The first tsunami arrived.
- 15:35 The second tsunami arrived.
- 15:36 The two DGs of Unit 6 tripped.

March 12, 2011 (Saturday)

- 8:13 Electric power interchange from the emergency DGs of Unit 5 and Unit 6 was enabled.

March 13, 2011 (Sunday)

- 13:20 With the power supply from the emergency DG of Unit 6, water injection by the condensate transfer pump was started. (Then, water was injected intermittently.)

March 14, 2011 (Monday)

- 14:13 Supply of water into the Spent Fuel Pool was started. (Then, water was supplied intermittently.)

March 16, 2011 (Wednesday)

- 13:10 The FPC was manually started. (Cycle operation without heat removal capability.)

March 18, 2011 (Friday)

- 17:00 Workers completed making holes (at three locations) on the roof of the reactor building.
- 19:07 The DG seawater pump was started.

March 19, 2011 (Saturday)

- 4:22 The second DG was started.
- 21:26 With the temporary power supply of the power supply vehicle, the RHR temporary seawater pump was started.
- 22:14 The RHR was manually started. (Cooling of the Spent Fuel Pool was started in emergency load mode.)

March 20, 2011 (Sunday)

- 16:26 The RHR was manually stopped. (Emergency thermal load mode)
- 18:48 The RHR was manually started. (Cooling of the reactor was started in stopped cooling mode.)
- 19:27 The water temperature of the reactor fell below 100°C and the reactor achieved a cold shutdown.

2.8 Status of Dose rate Around Power Station

As the MP halted, the dose rate around the power station could not be measured with MP. However, measurements were carried out with the monitoring car that was deployed as a replacement of MP in the vicinity of the main gate of the station. Figure 2.8-1 shows the measurement results.

In Unit 1, around 14:00 on March 12, the temporary air compressor for operating the major valve of the S/C vent valve (AO valve) was installed, and a drop in the D/W pressure was confirmed at 14:30. Since then, the workers performed vent operations, including those for Unit 2 and Unit 3, were performed several times.

For the dose rate, no big change in the background level before and after these vent operations was observed. However, from 4:00 to 7:00 on March 12, the dose rate increased. In addition, around 6:14 on March 15, the sound of an explosion was confirmed, and the background level of the dose rate increased before and after it.

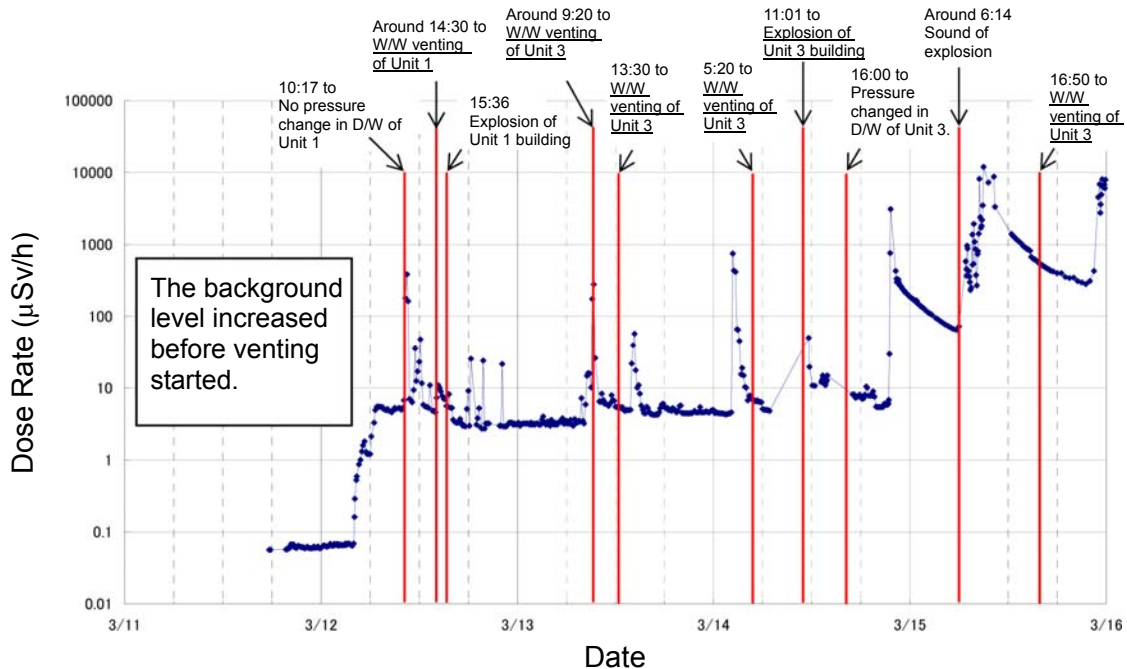

Fig. 2.8-1 Fukushima Daiichi Nuclear Power Station Fukushima Daiichi Nuclear Power Station Nuclear Power Plant Dose Rate in the Vicinity of Main Gate

2.9 Evaluation of Core core Conditions conditions of Unit 1 to Unit 3 at the Time time of Accident accident

TEPCO implemented the event progress analysis on the core conditions of Unit 1 to Unit 3 when the accident occurred, by using the severe accident analysis code. The analysis result is outlined in the following.

The analysis result indicates that in the shortest case, the reactor core damage started in Unit 1, 4 hours after the earthquake occurred. In comparison of with the shortest cases, the result also shows that the core damage started in Unit 2 and in Unit 3, respectively, 77 hours and 42 hours after occurrence of the earthquake. The time to the core damage in Unit 2 and Unit 3 was extended longer by the period of time during which the respective RCIC or HPCI worked.

2.9.1 Evaluation of Core core Conditions conditions of Unit 1 at tthe Time of Accidentaccident

- In the analysis, tThe analysis was implemented, assuming the condition of gaseous leak from the containment vessel (about 18 hours after occurrence of the earthquake) and operating conditions of the IC (it became inoperable after the station blackout). As a result, the main development is as shown below:
 - Time when exposure of the core started:
About three hours after occurrence of the earthquake
 - Time when the core damage started:
About four hours after occurrence of the earthquake
 - Time when the RVP was broken:
About 15 hours after occurrence of the earthquake
- After the assumed timing of the IC stop, the water level of the reactor reached the Top of Active Fuel in about two hours, then and this leading to the rector damage.
- Although the reactor pressure increases after the assumed timing of the IC stop, it remains around 8 MPa (abs) because of the Safety Relief Valve. After the reactor core is damaged, the melted pellets move to the lower plenum. Then, about 15 hours after the earthquake, the RPV breaks and the reactor pressure decreases rapidly.
-
- The pressure of the containment vessel temporarily increases because of the steam released from the RPV and hydrogen gas formed by the reaction of water and metal in the reactor. However, after that, the pressure shows a decreasing trend because of the leakage from the containment vessel assumed in the analysis, and then it decreases rapidly by the vent operation on March 12.
- The PCV temperature is over 300°C about 18 hours after occurrence of the earthquake, and well exceeds the designed temperature of the containment vessel (138°C).
- Hydrogen is generated almost simultaneously with the core damage, and there is the possibility that the explosion of March 12 was caused by the hydrogen generated then.

- Regarding radioactive substances to be released as a result of core damage, almost all noble gases are released to the atmosphere by the vent operation. According to the analysis result, approximately 1% of cesium iodide and less than about 1% of other nuclides are released.

2.9.2 Evaluation of Core Condition of Unit 2 at the Time of Accident

- In the analysis, the analysis was implemented, assuming the condition of gas phase leakage from the containment vessel (about 21 hours after the earthquake) and the following two cases of the amount of water injected by the fire pumps.

As a result, the main development is as shown below:

(Case 1) It is assumed that the workers injected an amount of water that allowed the reactor water level to be almost comparable with the measured value was injected.

(Case 2) It is assumed that the workers injected an amount of water that did not allow the reactor water level to be maintained in the fuel range was injected.

Time when exposure of the core started:

Approx. 75 hours after occurrence of the earthquake

Time when the core damage started:

Approx. 77 hours after occurrence of the earthquake

Time when the RVP was broken:

About 109 hours after occurrence of the earthquake (in the case of Case 2)

- The reactor water level gradually goes down after the RCIC stops, and the reactor core starts to be exposed. After the SRV is opened, the reactor core damage starts.
- The reactor pressure is kept high around the SRV operating pressure until the RCIC stops. As a result of opening of the SRV following the RCIC stop, the reactor pressure decreases rapidly, then going goes down to near atmospheric pressure.
- The pressure in the containment vessel gradually increases as the water temperature of the suppression pool rises. The opening of the SRV following the RCIC stop results in a temporary pressure buildup, and then the pressure shows a decreasing trend because of the leakage from the suppression chamber assumed in the analysis. (Note that it is currently unknown whether the assumed leak from the containment vessel actually occurred or whether that was only a problem of instrumentation.)
- A large amount of hydrogen results from the reaction of metal and water in a period when the reactor core is exposed and the temperature of fuel cladding tube starts to rise.
- Of the radioactive substances to be released due to the core damage, noble gases are released from the pressure vessel to the Suppression Chamber. With the assumed leak from the Suppression Chamber, almost total volume of the noble gases is to be released into the environment. For cesium iodide, the analysis result shows that the release rate is 1% or lower, and most of it exists in the Suppression Chamber. (It should be noted,

however, that behavior of radioactive substances greatly depends on the effect of the analysis conditions or uncertainty in models.)

2.9.3 Evaluation of Core core Conditions conditions of Unit 3 at the Time of Accident

- In the analysis, (The analysis was implemented, assuming the following two cases of the amount of water injected by the fire pumps. As a result, the main development is as shown below:

(Case1) It is assumed that the workers injected an amount of water that allowed the reactor water level to be almost comparable with the measured value was injected.

(Case 2) It is assumed that the workers injected an amount of water that did not allow the reactor water level to be maintained in the fuel range was injected.

Time when exposure of the core started:

Approx. 40 hours after occurrence of the earthquake

Time when the core damage started:

Approx. 42 hours after occurrence of the earthquake

Time when the RVP was broken:

About 66 hours after occurrence of the earthquake (in the case of Case 2)

- The reactor water level gradually goes down after the HPCI stops, and the reactor core starts to be exposed. After the SRV is opened, the reactor core damage starts.
- The reactor pressure is kept high around the SRV operating pressure until the HPCI stops. As a result of opening of the SRV following the HPCI stop, the reactor pressure decreases rapidly, then going goes down to near atmospheric pressure.
- The pressure in the containment vessel gradually increases as the water temperature of the suppression pool rises. Although the pressure temporarily goes high due to the opening of the SRV following the HPCI stop, it decreases by venting from the Suppression Chamber. Then, the pressure repeats repeatedly increasing/es and decreasingdecreases, depending on the venting operations.
- A large amount of hydrogen results from the reaction of metal and water in a period when the reactor core is exposed and the temperature of fuel cladding tube starts to rise. The possibility is pointed out that the explosion of March 14 was caused by the hydrogen generated in this period.
- Of the radioactive substances to be released due to the core damage, noble gases are released from the pressure vessel to the Suppression Chamber, and almost total volume of all the noble gases is are to be released into the environment by venting. For cesium iodide, the analysis result shows that the release rate is about 0.5%, and most of it exists in the Suppression Chamber. (It should be noted, however, that behavior of radioactive substances greatly depends on the effect of the analysis conditions or uncertainty in models.)

Source Material

(1) Report of Japanese Government to the IAEA Ministerial Conference on Nuclear Safety, 2011 June

- http://www.kantei.go.jp/jp/topics/2011/pdf/houkokusyo_full.pdf
- http://www.kantei.go.jp/jp/topics/2011/pdf/app_full.pdf

Chapter 3 Analysis of Causes of Accident Events and Extraction of Problems

Problems of the accident are that the cores were damaged and that radioactivity was discharged to the environment. We analyzed the accident to identify the causes for the accident with an event tree and extracted problems to clarify what made the accident expand and diminish.

In addition, in order to pick up problems exhaustively, we made analyses with the focus on functional aspects of “to shut off,” “to cool down” and “to confine.”

3.1 Flow of accident events

The event tree of progress of events in each reactor is shown in Fig. 3.1-1.

The event tree was prepared in a configuration that allows us to tell how power functions (DC power, external power and emergency DG) were lost by the initial event (earthquake) and the following tsunami, short-term core cooling operations (systems that do not depend on AC power such as IC, RCIC, and others) and transferring operations to cool shutdown (reactor depressurization, water injection to reactor, container ventilation, and others) or success or failure of mitigation measures (cooling damaged core and container and reactor building control). Also, it was prepared so that it clearly shows actions in the case where the power is restored and functions of facilities can be restored (existing and established severe accident management) and actions in the case like this time where power restoration was not possible and functions of facilities are difficult to restore.

For Unit 1, in addition to the loss of external power due to the earthquake, loss of emergency DG due to the tsunami made all the AC power unavailable. Besides, DC power was lost too. It was verified that the IC worked until the tsunami hit the power plant. It is assumed that the core was damaged after the tsunami arrived. Then, it is assumed that hydrogen generated in the core leaked from the container to the reactor building causing a hydrogen explosion and resulting in the discharge of radioactivity to the environment.

For Unit 2, because of the loss of external power due to the earthquake and loss of emergency DG due to the tsunami, all AC power was lost. Besides, DC power was lost too. Cooling the core was secured by the RCIC which was started to work prior to the loss of DC power and worked for a little less than three days until around 13:30 on March 14. But, it is guessed, since it took time to implement alternate water injection after stop working of the RCIC and injected water amount was too little, the core was damaged.

For Unit 3, because of the loss of external power due to the earthquake and loss of emergency DG due to the tsunami, all AC power was lost. But the RCIC and the HPCI worked and secured core cooling for one-and-a-half-day until DC power was ran out at around 2:40 on March 13. But, it is assumed, since it took time to implement alternate water injection after stop of the RCIC and the HPCI and injected water amount was too little, the core was damaged. After that, it is guessed, hydrogen generated in the core leaked to the PCV and the R/B causing a hydrogen explosion and resulting in the discharge of radioactivity to the environment.

For Unit 4 (under suspension due to periodical inspection), because of the loss of external power due to the earthquake and loss of emergency DG due to the tsunami, all AC power was lost. Besides, DC power was lost too. There were fuels with relatively high decay heat taken out from the core shortly before that time in the SFP but water in the pool could not be cooled with the FPC due to the loss of power. And the 5th floor of the Reactor No. 4 building was damaged by a hydrogen explosion. Afterward, water injection to the SFP was executed with a concrete pump vehicle.

In Unit 5 (under suspension due to periodical inspection), fuels were loaded in the reactor and a test for pressure resistance and leakage of the RPV with the control rods being fully inserted was performed at the time of the earthquake. Although all AC power was lost due to the earthquake and the tsunami, AC power was secured by the power provided from Unit 6. The seawater pumps in the RHR line were damaged by the tsunami, but the makeshift seawater pumps were used for the RHR and the spent fuel pool and the reactor well were cooled by the RHR line. With this, the reactor got in a state of cold shutdown.

Unit 6 (under suspension for periodical inspection) was in a state of cold shutdown with all fuels being loaded and the upper lid of the RPV being shut. Since external power was lost due to the earthquake three emergency DGs started to work automatically but two Units of them became inoperable because functions of the seawater pump and the power panel were lost due to attack of the tsunami. As AC power was secured with the remaining one Unit (air-cooling type), power supply for Unit 5, cooling the SFP and for the reactor was performed. The seawater pumps in the RHR line were damaged by the tsunami, but the makeshift seawater pumps were used for the RHR and the reactor well was cooled by the RHR line. With this, the reactor returned to the state of cold shutdown.

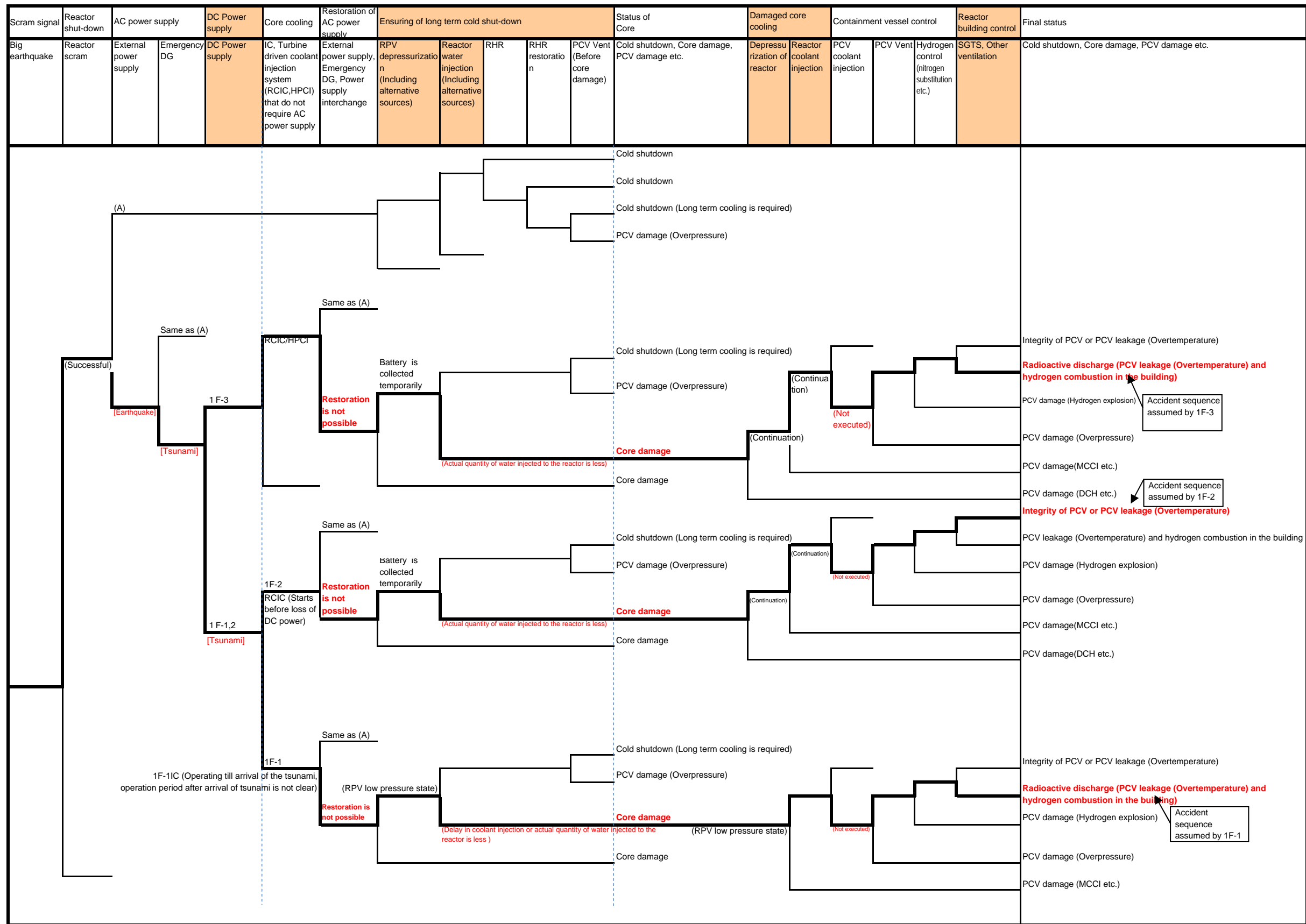

Figure 3.1-1 Disaster identification events tree in Fukushima Daiichi Nuclear Power Station, Units 1 to 3

3.2 Extraction of subject from accident event progress

3.2.1 Cause analysis from accident event progress (event tree)

3.1 The following three items have been extracted as the main factors of core damage and emission of radioactivity to the environment from the progress flow of accident event (event tree).

- 1) Inability to supply AC power
- 2) Inability to remove heat from nuclear reactor
- 3) Hydrogen leakage to building and hydrogen explosion

Cause analysis of the above-mentioned three factors was executed to extract the points to examine.

Moreover a common factor which obstructed the work was discovered through the cause analysis. These factors were analyzed to extract the points to examine.

(1) Inability to supply AC power

Figure 3.2.1-1 shows the result of analysis of the cause that AC power could not to be supplied.

Before the tsunami, the AC power was supplied by an external source before the earthquake occurred and it was supplied by an emergency DG after the earthquake occurred.

The AC power could not be supplied to the equipment and for operation for reasons including the inability to supply power from the external source, inability to supply power with an emergency DG, inability to jointly use power supply and inability to restore power supply at early stage.

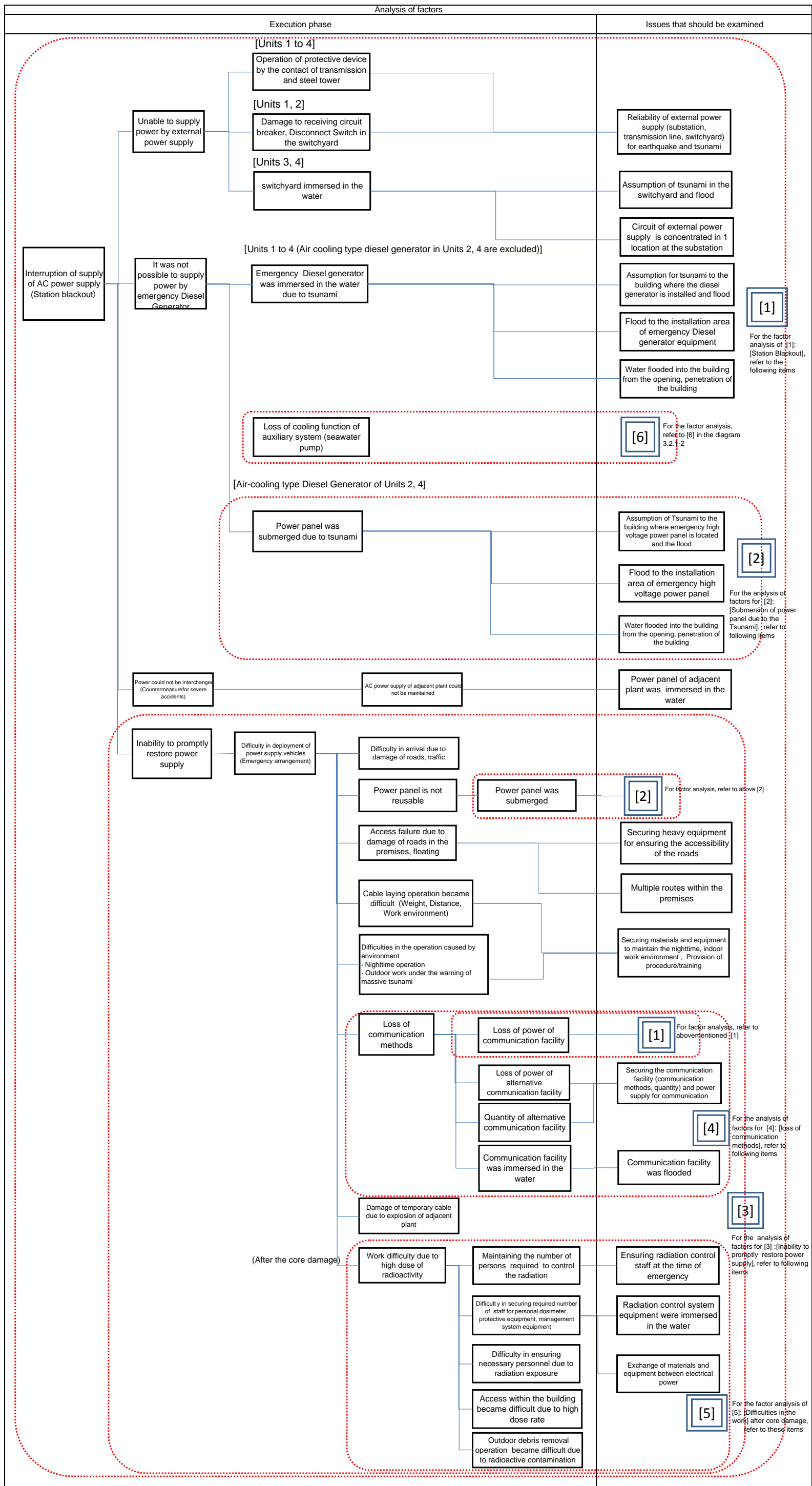

Figure 3.2.1-1 Analysis of causes for interruption of AC power supply

a. Inability to supply power from external source

The power supply from the outside was able to be received from the new Fukushima substation. After the earthquake, however, the power supply lost its function with the damage to the substation equipment due to the earthquake, with the damage to the receiving breaker and disconnecting switch in the switchyard in the power plant due to the earthquake, and with the movement of protection instrument caused by the power line coming into contact with the steel tower and such like.

Note that traces where tsunami reached were confirmed at the switchyard of Units 3 and 4.

From these points the following is listed as the points to examine to maintain the power supply with an external source.

- Reliability of external source (substation, power line and switchyard) in the event of an earthquake and tsunami
- Flooding of switchyard by tsunami
- Concentration of external source lines in one place in substation (multiplexing of line)

b. Inability to supply power with emergency diesel generator

The power had been supplied by the emergency DG after the earthquake. After the tsunami, the functions of the seawater pumps were lost except for Unit 6 and the functions of the DG were lost because of flooding in the building. Although air-cooled emergency DG of Units 2 and 4 were not flooded by the tsunami, they lost their power supply functions because the high-voltage power supply panel was flooded.

From these points the following is listed as the points to examine to maintain the power supply by emergency DG.

- Flooding in installation area of emergency power generating machine (DG and power supply panel)
- Flooding in building from opening and penetration part of building
- Flooding of cooling seawater system pump for emergency DG

Note that AC power could be supplied to Units 5 and 6 with the air-cooled emergency DG of Unit 6.

c. Inability to jointly use power supply

Joint use of power supply from the adjacent Unit prepared for a severe accident was not performed for Units 1 to 4 since the power was lost in all these Units.

Joint use of a power supply could be performed since the AC power had been supplied to Units 5 and 6 from the emergency DG of Unit 6.

d. Inability to restore power supply at early stage (excluding Units 5 and 6 for which AC power was secured)

Since the AC power was lost, the workers made an attempt to restore the power supply at an early stage by arranging to promptly procure from

outside the power plant power supply vehicles for emergencies. As a result, however, the power supply could not be restored before the core became damaged.

Work to restore the power at an early stage was frequently interrupted by the aftershocks and official tsunami warnings. Moreover night work or work conducted under an official tsunami warning had a lower efficiency.

In work in the building (cable laying work), interior lighting was lost along with the loss of the power supply. Work was done by using the limited amount of flashlight and such like. In addition the communication equipment (paging and security telephone) excluding some pieces of apparatus were unusable because of flooding or because they lost their power supply. It became impossible to use cellular phones and PHS gradually as their batteries ran out. A means of communications between worksites, or with MCR or emergency stations were broken off and work became difficult.

From these points the following are listed as points to examine to restore the power supply at an early stage

- Flooding on power supply panel

Moreover the following are listed as the points to examine to improve the effectiveness of recovery efforts.

- Securing the materials and equipment to secure a working environment in the nighttime or room
- Securing heavy equipment to secure accessibility of roads
- Having multiple routes in the plant
- Securing communication equipment (communication means and amount) and power supply for communication including batteries
- Flooding on communication equipment

Furthermore, "Maintenance of procedure and training" is also extracted as a point to examine to improve the effectiveness of work though it is not limited to the power supply restoration.

After the hydrogen explosion that followed the reactor core damage, there was a difficult work environment in the plant.

Workers got injured by the hydrogen explosion of the reactor building. In Unit 1, there was a loss such as the damage of a cable installed for emergencies to execute alternative water filling using the SLC pump (stand by liquid control). Moreover labor and time were spent on work to remove wreckage polluted with radioactivity, and time was required for outdoor work.

In addition a lot of personal dosimeters and the radiation control system were flooded by the tsunami. Hence there were not enough personal dosimeters and there were not enough for all workers to wear one.

From these points the following are listed as the points to examine.

- Joint use of materials and equipment between electric power companies
- Securing of radiation control workers for emergency
- Flooding on radiation control system

(2) Inability to remove heat from nuclear reactor (excluding Units 4, 5 and 6 that were stopped)

Figure 3.2.1-2 shows the result of analyzing the reason why heat could not be removed from the nuclear reactor.

IC (Unit 1), HPCI (Units 1 to 3) and RCIC (Units 2 and 3) were built as heat removing equipment and as high-pressure system equipment to decompress the nuclear reactor.

In addition in Unit 1, SRV (relief valve function/automatic decompression function) to decompress the nuclear reactor and CS that conducts injection to the reactor core at low pressure were installed. In Units 2 and 3, RHR (low-pressure injection mode) was installed in addition to SRV and CS.

Moreover Units 1 to 3 had a containment vessel vent Unit to prevent overpressure of containment vessel and some severe accident measure equipment.

It was impossible to remove heat from the nuclear reactor from the view of the equipment and operation for the following reasons: inability to conduct decompression with SRV, inability to remove heat with CS and RHR, inability to remove heat with severe accident measure equipment (alternative water filling), and difficulty in venting containment vessel.

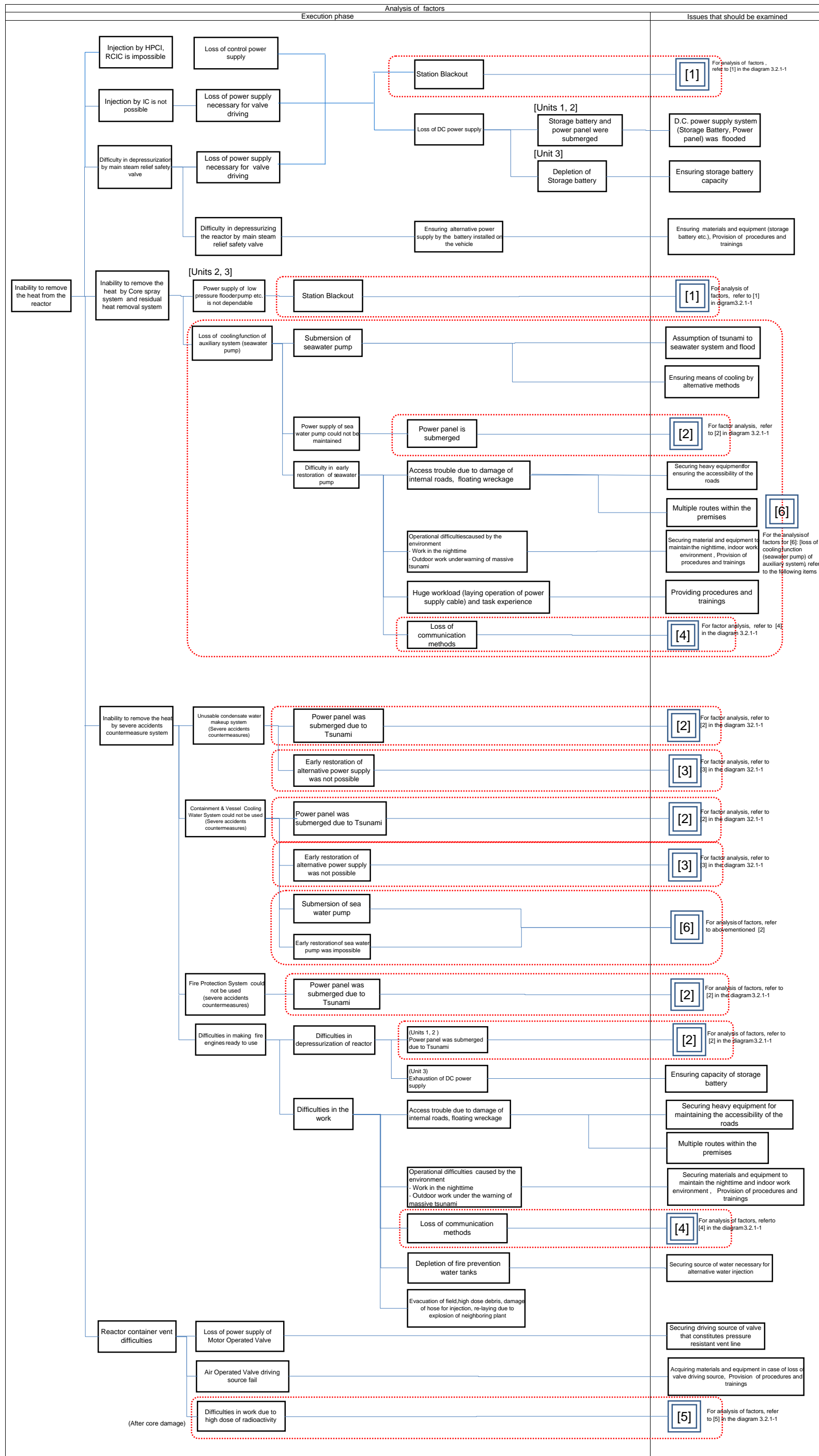

Figure 3.2.1-2 Analysis of causes of inability to remove heat from the reactor

a. Inability of to cooling by with emergency condenser, high pressure injection system and reactor core isolation cooling system

IC in the Unit 1 was manually shut down before the tsunami reached the power station to protect the cooling rate. However the DC power was lost under the impact of tsunami with the valve closed, operation became impossible. Thereafter, the workers opened the valve and confirmed the generation of steam. Nevertheless, the extent of the operation performance is unknown. Actually, we suppose that only a limited level of cooling could be achieved.

The HPCIs in the Unit 1 and Unit 2 were in standby mode, because they did not reach the start-up condition before the tsunami arrived. However, because their DC power was lost under the impact of the tsunami, their functions were lost. The HPCI in Unit 3 started up automatically because the reactor water level fell. Then, the system must have shut down due to the fall in reactor pressure, which led to an inability to operate due to lack of DC power.

The RCIC in Unit 3 was started up manually after the reactor scram. The system was started up and shut down for adjustment of the reactor water level. While the operation was continued using battery even after the tsunami arrived, the operation must have shut down when the battery power ran out.

Based on above, the following items are listed as points to examine to ensure maintenance of functions of IC, HPCI and RCIC.

- Submergence of D.C. power supply systems (battery cell, power supply panel)
- Security of battery capacity

b. Inability to conduct depressurization with main steam safety relief valve

In Unit 1 and Unit 2, the DC power necessary to drive SRVs was lost due to submergence under the impact of the tsunami. With regard to Unit 3, it stopped working with other components operated by DC power on March 13 due to exhaustion of DC power, while the DC power was not affected by submergence caused by the tsunami.

To achieve alternative coolant injection, it was necessary to depressurize the reactor by operating the SRVs. Therefore, the workers needed to open an electromagnetic valve to supply nitrogen as a source to drive the SRVs.

In Unit 3, the workers tried to open electromagnetic valves by using the on-board batteries of fire engines when they came to the site for alternative water injection. Because the battery cells stored in the station were used to recover the instrumentation in Unit 1 and Unit 2, batteries were collected from the vehicles of employees who were working in the on-site disaster countermeasure headquarters and connected to the instrumentation panels. Finally, after about 6 hours from the loss of the high-pressure injection system function, the SRV were opened and rapid depressurization of the reactor could be achieved.

Based on above, following items are listed as points to examine to maintain depressurization function by SRVs.

- Inability of supplying AC power (See 3.2.1(1))
- Submergence of D.C. power supply systems (battery cell, power panel)
- Security of battery capacity
- Security of materials and equipment to ensure SRV operation in the event of the loss of DC power and implementation of the procedure and the training thereof

c. Inability to remove residual heat with core spray system (Units 1 to 3) and residual heat removal system (Units 2 and 3)

The inability to remove residual heat by using CS and RHR (low pressure injection mode) is attributable to an inability to supply AC power and the function loss of seawater pumps for cooling related auxiliary components. The inability to supply AC power was already explained in 3.2.1(1). The loss of cooling function in seawater pumps occurred because of the submergence caused by the tsunami that exceeded the estimated highest level (O.P. 5.7 m). All of the seawater pumps stopped working simultaneously.

With regard to the recovery of seawater pumps, considerable time was spent due to multiple factors as below: access to sea pump installation area was extremely restricted due to the damage caused by the Earthquake and the tsunami, while spare seawater pumps were maintained; work was interrupted repeatedly due to aftershocks; work efficiency was poor because of the issue of great tsunami alarm at night and such like. Besides the seawater pumps, the power panels necessary for the function of the component cooling system were submerged. Therefore, early restoration of this system was extremely difficult.

Based on above, the following items are listed as points to examine to maintain residual heat removal function by CS and RHR.

- Estimation of tsunami and submergence of seawater systems
- Security of cooling method by using alternative approaches

d. Inability to remove residual heat by systems used for as severe accident countermeasure

As systems to serve as a severe accident countermeasure for the loss of injection function, MUWC, CCS and FP had been prepared.

However, almost none of these could be used for most of the systems due to the station blackout and the function loss of auxiliary component cooling system.

While it was stipulated to use FPs as an alternative injection system based on severe accident countermeasures, the function of the motor operated fire extinguishing pumps was lost due to the power loss. While the pumps driven by a diesel motor could be operated temporally in Unit 1, they were shut down later due to a malfunction. It seems that these pumps failed to achieve start-up operation in Unit 2, the cause of this failure is unknown, making it difficult to judge whether or not this event is attributable to

component failure. In Unit 3, these pumps operated temporarily and shut down later. Details of this event are unknown.

Workers tried to inject water into the reactor with fire engines that were maintained as a part of earthquake preparedness after the earthquake that struck Kashiwazaki Kariwa Nuclear Power Station. However, considerable time was spent before actually injecting water to the reactor due to multiple factors as below: access to the outdoor area was extremely difficult; work was interrupted repeatedly due to aftershocks; work efficiency was poor because of the issue of great tsunami alarm at night and such like. As a consequence, it was impossible to inject water before core damage.

Although the fresh water injection to the reactor was started by using the fire water tank as a water source, the water source was switched to the seawater reserved in back wash valve pit in the afternoon on March 12 due to exhaustion of the fresh water.

Further, workers were injured in the hydrogen explosion in the reactor building. Hoses and fire engines prepared for alternative injection were damaged by the hydrogen explosion and made unavailable. Materials and equipment left behind on site caused disturbance in outdoor work later, which became a contributing factor for the prolonged work period.

Based on above, following items are listed as points to examine to secure residual heat removal function by using systems for severe accident countermeasure:

- Loss of AC power
- Loss of seawater pump function
- Security of water source necessary for alternative injection

e. Containment vent work

The purpose of the containment venting is to secure the integrity of the reactor containment Unit by relieving elevated containment pressure. Further, the venting may be used to discharge heat when reactor heat is accumulated inside the containment due to the loss of safety-related systems.

In Units 1 to 3 of Fukushima Daiichi Nuclear Power Station, the purpose of the vent work at the initial phase was to relieve pressure.

In Units 1 to 3, motor-operated valves and AO valves were closed on the lines that constituted the concerned systems before conducting the containment vent.

With regard to the motor-operated valves, the entire AC power was lost. On top of it, pneumatic air for actuating the AO valves was lost. These events resulted in the inability to start early venting by remote control.

In the case of Unit 1, motor-operated valves were opened manually. The AO valve that constitutes the main line (i.e., large valve) could not be easily opened by manual operation based on its structure. Therefore, the small valve was opened, instead. However, the core damage had occurred already at that time and the radiation level in this area was high. Besides, the workers continued to operate in darkness and in a narrow space. These factors prevented them from accessing the valve. The workers gave up on

their plan to open the valve manually and decided to use the temporary compressor for the work. As a consequence, it took a long time until the start of venting.

While venting was finally achieved on Unit 1 and Unit 3, it took a long time to reconstruct a vent line due to the loss of power and pneumatic air. It was not clear whether or not the venting was achieved in Unit 2, because the containment pressure failed to reach the actuation pressure of the rupture disk continuously for a long time after the reconstruction of the vent line.

Based on above, following items are listed as points to examine to secure implementation of containment vent:

- Security of power to drive valves that constitute the containment vent line
- Security of materials and equipment to achieve prompt line configuration in the loss of electric power and pneumatic source to drive the valves
- Improvement of procedure and training

(3) Hydrogen leakage to building and hydrogen explosion (excluding Units 5 and 6 where hydrogen explosion did not occur)

Analysis results of the cause of hydrogen leakage to the building and hydrogen explosion are indicated in Figure 3.2.1-3. Hydrogen leakage to the building is estimated to be attributable to the hydrogen generated from fuel cladding due to core damage. This hydrogen seems to have leaked out to the reactor building via the containment vessel. With regard to the leakage from the containment to the reactor building, leakage through the flange gasket or penetration sealing with the increase of containment pressure is suspected. With regard to Unit 2, pressure was lost from the S/C and the containment at around 6:00 on March 15. Further investigation is needed to identify the leakage route from RPV and the containment upon convergence of the accident.

With regard to Unit 4, generation of a large amount of hydrogen in the fuel pool is unlikely based on the analysis of nuclides obtained by sampling the fuel pool water in addition to the result of visual observations of the fuels in the pool using monitor cameras.

Meanwhile, the SGTS exhaust pipe in Unit 4 merged with the exhaust pipe of Unit 3 before the stack. Therefore, the hydrogen generated in Unit 3 may have migrated in the Unit 4 building via the SGTS exhaust pipe, resulting in a hydrogen explosion in the Unit 4 reactor building after accumulating there for a while. Based on the radiation measurement result, the radiation dose was the highest at the exit of SGTS filter train in Unit 4. The dose gradually decreased as the measurement point moves closer to the inlet. These results suggest the appropriateness of the above-mentioned scenario. While an AO valve was installed on the SGTS exhaust pipe, the valve was stuck open due to the loss of pressurized instrumentation air for normal operation as well as inability to get air supply for valve actuation from back-up system (dedicated air cylinder) in the event of containment venting due to power loss.

In every plant, prior detection of hydrogen leakage into the reactor building could not be achieved. Besides, there was no means available for removing the hydrogen with a loss of AC power.

Based on above, following items are listed as points to examine to prevent hydrogen leakage to the buildings and the hydrogen explosion in the event of hydrogen negation due to core damage and such like:

- Hydrogen migration among the Units connected via common stack
- Migration of hydrogen from containment vent line to the reactor building
- Accumulation of hydrogen in the reactor building
- Security of materials and equipment to remove hydrogen gas from the building
- Improvement of procedures and training

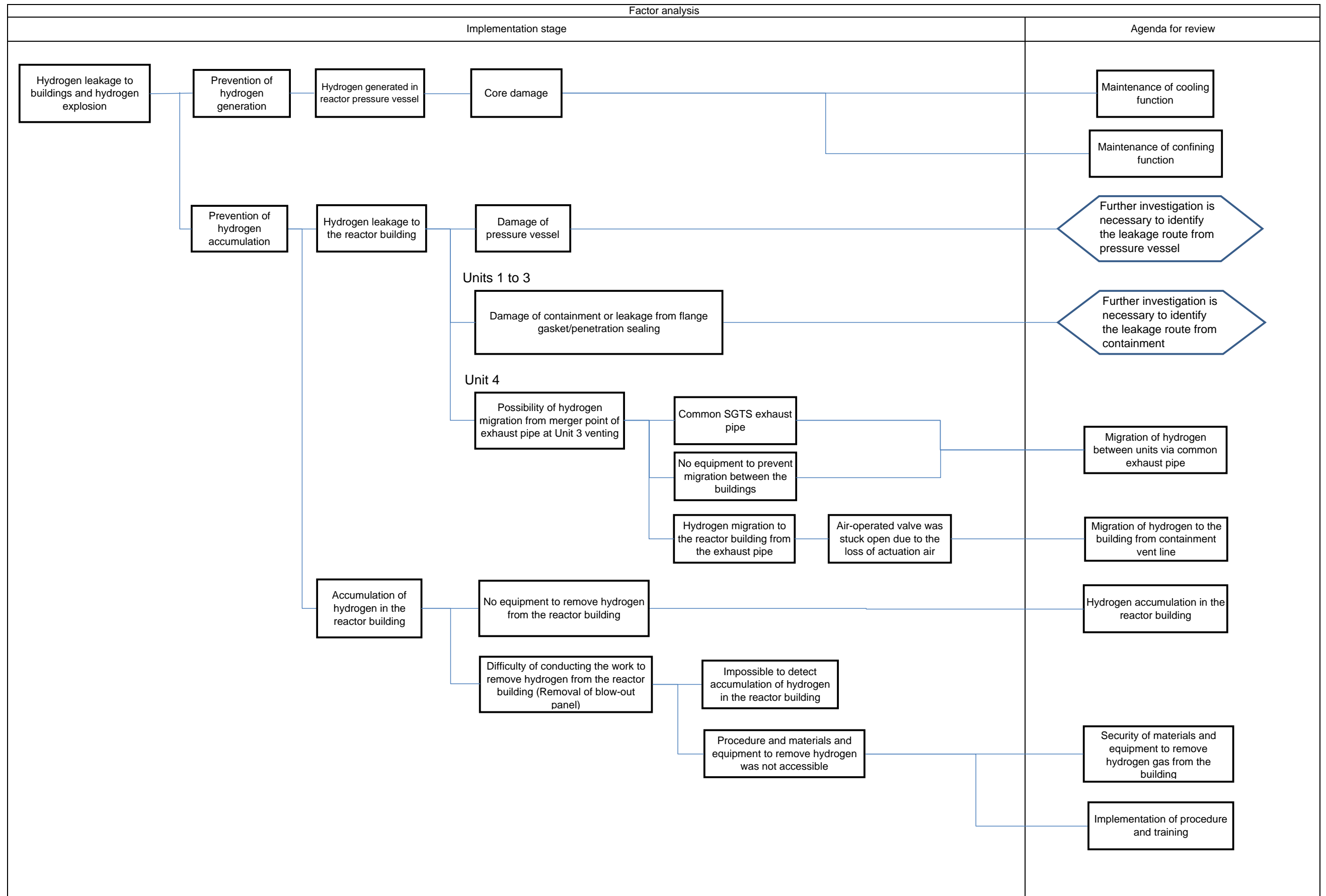

Figure 3.2.1-3: Hydrogen leakage to buildings and hydrogen explosion: Cause analysis

3.3 Arrangement of problems confirmed from functional viewpoint

Fukushima Daiichi Nuclear Power Station Units 1 to 4, located adjacent to each other, were different in condition when the earthquake and tsunami occurred. Units 1 to 3 were producing their rated power, while Unit 4 had been stopped to undergo a periodic inspection (with all fuel discharged). In addition, Unit 5 and 6 of the power station are located away from Units 1 to 4. These requirements caused differences in the progress of phenomena.

3.3.1 Causal analysis of the accident in Units 1 to 3 and management of issues

When a nuclear power station is producing its full rated power, the functions necessary for placing it in a cold shutdown state are “stopping,” “cooling,” and “confining,” and causes of failures in the functions have been analyzed. The basic requirements (facility environment) necessary for the implementation of the operations, “stopping,” “cooling,” and “confining,” have also been analyzed.

Common factors (permanently installed power source unavailable, alternative power supply (power supply vehicle) unavailable, and unavailable cooling components) derived from them have furthermore been analyzed.

Tables 3.3-1 to 3.3-3 show the results of analyses on the causes of the accident, classified by functions of the **Units** (Units 1 to 3) **producing rated power**, and the results of arrangement.

Table 3.3-1 Analysis of cause of the accident at Fukushima Daiichi Nuclear Power Station Unit 1 and Sorting of the problems (1/2)

Safety function		Related facility, etc.	Function loss or function degradation	Cause analysis	Problem		
Stoppage	Emergency reactor shut-down function	Safety protection system, control rod and control rod	○ (Normal operation when earthquake occurred)	-	-		
	Alternative reactivity control	Recirculation pump trip (AM)	- (Not required as scram was successful)	-	-		
		Alternative control rod insertion	- (Not required as scram was successful)	-	-		
Sub-criticality maintenance function	Boric acid water injection system	- (Not required as scram was successful)	-	-			
Support systems	Power supply function	External power supply	X	Loss of external power supply due to the earthquake	Receiving circuit breaker of Ookuma Line 2L in the switchyard of Unit 1/2 damaged due to the earthquake	(1) Reliability of switchyard circuit breaker	
		Emergency diesel generator	X	Function loss due to submergence	Submergence of emergency diesel generator due to the tsunami	(2) Submergence of the emergency diesel generator	
		6.9 kV high pressure power supply	X	Function loss due to submergence	Submergence of 6.9 kV high pressure power supply panels due to tsunami	(3) Submergence of 6.9 kV high pressure power supply panels	
		480 V low pressure power supply	X	Function loss due to loss of 6.9 kV high pressure power supply	Submergence of 6.9 kV high pressure power supply panels due to tsunami	Same as (3)	
				Function loss due to submergence	Submergence of 480 V low pressure power supply panels due to tsunami	(4) Submergence of 480 V low pressure power supply panels	
	125 V DC power supply	X	Function loss due to submergence	Submergence of 125 V DC power supply panels due to tsunami	(5) Submergence of 125 V DC power supply panels		
	Alternative power supply function	Power supply interchange (AM)	X	Power supply interchange unavailable from adjacent plants	Loss of station power of adjacent plant (Unit 2) due to tsunami	(6) Submergence of power supply panels of the adjacent plant	
		Power source car (emergency arrangement)	X	Difficulty in reaching	Difficulty in reaching due to damaged roads and traffic jams	(7) Procurement of alternative power supply from	
				Difficulty in connection work	Unable to connect due to submergence of DC power supply panels of Unit 1	Same as (3), (4)	
					Difficulty in laying cables (weight, isolation, work environment)	(8) Alternative power supply cable laying	
				Intermittent aftershocks and continuous issue of large tsunami warnings	Loss of communication means due to loss of AC power supply	(9) Communication means at a loss of AC power	
	Power supply interruption	Cables damaged and power supply car stopped automatically due to explosion in the Unit 1 Reactor Building	-				
	Auxiliary cooling function	Containment vessel cooling seawater system	X	Function loss due to submergence	Submergence of containment vessel cooling seawater pump due to the tsunami	(10) Submergence of containment vessel cooling seawater pump	
				Function loss due to loss of AC power supply	Submergence of 6.9 kV high pressure power supply panels due to tsunami	Same as (3)	
		Cooling seawater system	X	Function loss due to submergence	Submergence of cooling seawater pump due to the tsunami	(11) Submergence of component cooling seawater	
				Function loss due to loss of AC power supply	Submergence of 6.9 kV high pressure power supply panels due to tsunami	Same as (3)	
				Function loss due to loss of DC power supply	Submergence of 125 V DC power supply panels due to tsunami	Same as (5)	
		Reactor component cooling water system	X	Function loss due to loss of component cooling seawater system	Submergence of cooling seawater pump due to the tsunami	Same as (11)	
Function loss due to loss of AC power supply	Submergence of 6.9 kV high pressure power supply panels due to tsunami			Same as (3)			
Function loss due to loss of DC power supply	Submergence of 125 V DC power supply panels due to tsunami	Same as (5)					
Cool down	Function to prevent over-pressurization of reactor coolant pressure boundary	Main steam relief safety valve (safety valve function)	- (Controlled with emergency condenser)	-	-		
	High pressure core cooling function	High pressure coolant injection system	X	Function loss due to loss of DC power supply	Submergence of 125 V DC power supply panels due to tsunami	Same as (5)	
		Emergency condenser (main body)	△ (Temporary operation)	Deterioration in function due to loss of DC power supply (remote operation not possible)	Submergence of 125 V DC power supply panels due to tsunami	Same as (5)	
				Isolated with isolation signal transmission (Open halfway due to loss of AC power supply)	Pipe break detection circuit operational due to loss of DC power supply	(12) Verification of the design of isolation signal for loss of DC power supply	
		Emergency condenser (support system)	△ (Temporary operation)	Demineralized water supply system	X	Function loss due to loss of AC power supply	Submergence of 480 V low pressure power supply panels due to tsunami
	Fire protection system			Unable to use electric pump due to loss of external power supply	Receiving circuit breaker of Ookuma Line 1L damaged due to the earthquake	Same as (1)	
	Alternative injection function (high pressure)	Boric acid water injection system (AM)	X	Function loss due to loss of AC power supply	Submergence of 480 V low pressure power supply panels due to tsunami	Same as (4)	
				Difficulty in power supply recovery operation	[Recovery not possible] Cables damaged and power supply car stopped automatically due to explosion in the Unit 1 Reactor	-	
		Control rod drive water system (AM)	X	Function loss due to loss of AC power supply	Submergence of 480 V low pressure power supply panels due to tsunami	Same as (4)	
				Function loss due to loss of DC power supply	Submergence of 125 V DC power supply panels due to tsunami	Same as (5)	
	Reactor depressurization function	Main steam relief safety valve (relief valve function /	X	Function loss due to loss of component cooling seawater system	Submergence of cooling seawater pump due to the tsunami	Same as (11)	
				Function loss due to loss of DC power supply	Submergence of 125 V DC power supply panels due to tsunami	Same as (5)	
	Low pressure core cooling function	Core spray system	X	Injection disabled as reactor depressurization function cannot be used	Submergence of 125 V DC power supply panels due to tsunami	Same as (5)	
				Function loss due to loss of AC power supply	Submergence of 6.9 kV high pressure power supply panels due to tsunami	Same as (3)	
				Function loss due to loss of DC power supply	Submergence of 125 V DC power supply panels due to tsunami	Same as (5)	
Function loss due to loss of containment vessel cooling seawater system				Submergence of containment vessel cooling seawater pump due to the tsunami	Same as (10)		
Makeup water system (AM)	X	Injection disabled as reactor depressurization function cannot be used	Submergence of 125 V DC power supply panels due to tsunami	Same as (5)			
		Function loss due to loss of AC power supply	Submergence of 480 V low pressure power supply panels due to tsunami	Same as (4)			

Table 3.3-1 Analysis of cause of the accident at Fukushima Daiichi Nuclear Power Station Unit 1 and Sorting of the problems (2/2)

Safety function	Related facility, etc.		Function loss or function degradation	Cause analysis	Problem	
Alternative injection function (low pressure)	Containment vessel cooling system (AM)	X	Injection disabled as reactor depressurization function cannot be used	Submergence of 125 V DC power supply panels due to tsunami	Same as (5)	
			Function loss due to loss of AC power supply	Submergence of 6.9 kV high pressure power supply panels due to tsunami	Same as (3)	
			Function loss due to loss of DC power supply	Submergence of 125 V DC power supply panels due to tsunami	Same as (5)	
			Function loss due to loss of containment vessel cooling seawater system	Submergence of containment vessel cooling seawater pump due to the tsunami	Same as (10)	
	Fire protection system (AM)	X	Injection disabled as reactor depressurization function cannot be used	Submergence of 125 V DC power supply panels due to tsunami	Same as (5)	
			Diesel driven extinguishing pump shutdown	Mechanical malfunction (presumed)	-	
	Fire engine (Chuetsu coast earthquake response)	△ (insufficient flow rate, difficulty in working)	Injection disabled as reactor depressurization function cannot be used	Submergence of 125 V DC power supply panels due to tsunami	Same as (5)	
			Difficulty in ensuring the required coolant injection flow rate	Difficulty in ensuring the capacity of the fire protection water tank used as the water source	(13) Depletion of fresh water source	
			Difficulty in working	Obstacles due to the impact of the earthquake and tsunami	(14) Obstacles due to the earthquake and tsunami	
				Site evacuation due to explosion in the Unit 1 Reactor Building and high radiation dose	(15) Deterioration in work environment due to hydrogen explosion and rise in radiation dose	
				seawater injection hose damaged due to explosion in the Unit 1 Reactor Building → relaying	Same as (15)	
			Intermittent aftershocks and continuous issue of large tsunami warnings	-		
Loss of communication means due to loss of AC power supply	Same as (9)					
Containment isolation	Main steam isolation valve	○	(Normal operation)	-	-	
Function for removing heat from containment vessel	Containment vessel cooling system	X	Function loss due to loss of AC power supply	Submergence of 6.9 kV high pressure power supply panels due to tsunami	Same as (3)	
			Function loss due to loss of containment vessel cooling seawater system	Submergence of containment vessel cooling seawater pump due to the tsunami	Same as (10)	
	Shutdown cooling system	X	Function loss due to loss of AC power supply	Submergence of 6.9 kV high pressure power supply panels due to tsunami	Same as (3)	
			Function loss due to loss of DC power supply	Submergence of 125 V DC power supply panels due to tsunami	Same as (5)	
			Function loss due to loss of component cooling seawater system	Submergence of cooling seawater pump due to the tsunami	Same as (11)	
	Alternative heat removal function	Alternative containment vessel spray with makeup water	X	Function loss due to loss of AC power supply	Submergence of 480 V low pressure power supply panels due to tsunami	Same as (4)
Alternative containment vessel spray with fire protection system (AM)		X	Unable to use electric pump due to loss of external power supply	Receiving circuit breaker of Ookuma Line 1L in the switchyard of Unit 1/2 damaged due to the earthquake	Same as (1)	
			Diesel driven extinguishing pump shutdown	Mechanical malfunction (presumed)	-	
Pressure withstanding reinforced vent (AM)		△ (Time required due to blackout)	Difficulty in vent operation	Operation not implemented for alternative containment vessel spray	Priority for feed water and alternative coolant injection to emergency condenser (presumed)	-
				Submergence of 125 V DC power supply panels due to tsunami (Remote operation of air-operated containment vessel vent valve not possible)	Same as (5)	
				Drop in pressure of instrument air due to loss of external power	(16) Difficulty in ensuring compressed air	
				Unable to open the electric valve of cylinder line due to blackout and rise in radiation	Same as (4) and (15)	
				Difficulty in accessing due to rise in radiation dose	Same as (15)	
Loss of communication means due to loss of AC power supply		Same as (9)				
Difficulty in maintaining the air pressure and power supply of AO		-				
Drywell cooler (AM)	X	Function loss due to loss of AC power supply	Submergence of 480 V low pressure power supply panels due to tsunami	Same as (4)		
		Function loss due to loss of component cooling seawater system	Submergence of component cooling seawater pump due to the tsunami	Same as (11)		
Reactor coolant cleanup system (AM)	X	Function loss due to loss of AC power supply	Submergence of 480 V low pressure power supply panels due to tsunami	Same as (4)		
		Function loss due to loss of component cooling seawater system	Submergence of component cooling seawater pump due to the tsunami	Same as (11)		
Radioactive material release reduction function	Stand-by gas treatment system	X	Unable to operate due to loss of DC power supply	Submergence of 480 V low pressure power supply panels due to tsunami	Same as (4)	
Other	Containment vessel	X	Leakage generation	Deterioration in the seal of flange gasket and penetration due to loss in the function for removing heat from containment vessel	(17) Heat resistance and pressure resistance of gasket and penetration seal	
	Reactor building	X	Damage due to hydrogen explosion	Hydrogen generation due to the reaction of zircaloy and water	-	
Hydrogen leakage from containment vessel penetration part				-		
Other	Important functions related to safety	X	Function loss due to loss of AC power supply	Submergence of 480 V low pressure power supply panels due to tsunami	(18) Hydrogen retention in reactor building	
			Function to determine the condition of the plant during an accident	Submergence of 125 V DC power supply panels due to tsunami	Same as (5)	
	Function to determine abnormal conditions	X	Communication equipment	Function loss due to loss of AC power supply	Submergence of 480 V low pressure power supply panels due to tsunami	Same as (4)
			Emergency lighting	Function loss due to loss of AC power supply	Submergence of 480 V low pressure power supply panels due to tsunami	Same as (4)
Function loss due to loss of DC power supply	Submergence of 125 V DC power supply panels due to tsunami	Same as (5)				

○: Normal operation; △: Insufficient operation; X: Unable to operate; -: Operation not required
(Note) AM: Accident management (Severe accident measures)

Table 3.3-2 Analysis of cause of the accident at Fukushima Daiichi Nuclear Power Station Unit 2 and Sorting of the problems (1/2)

	Safety function	Related facility, etc.	Function loss or function degradation	Cause analysis	Problem	
Stoppage	Emergency reactor shut-down function	Safety protection system, control rod and control rod	○ (Normal operation when earthquake occurred)	-	-	
	Alternative reactivity control	Recirculation pump trip (AM)	- (Not required as scram was successful)	-	-	
		Alternative control rod insertion	- (Not required as scram was successful)	-	-	
	Sub-criticality maintenance function	Boric acid water injection system	- (Not required as scram was successful)	-	-	
Support systems	Power supply function	External power supply	X	Loss of external power supply due to the earthquake	Receiving circuit breaker of Ookuma Line 2L in the switchyard of Unit 1/2 damaged due to the earthquake Circuit breaker for Ookuma Line 2L in new Fukushima substation damaged	(1) Reliability of switchyard circuit breaker -
		Emergency diesel generator	X	Function loss due to submergence	Emergency diesel generator submerged in water due to the tsunami (2A) and power source panels submerged (2B)	(2) Submergence of the emergency diesel generator facility
		6.9 kV high pressure power supply	X	Function loss due to submergence	Submergence of 6.9 kV high pressure power supply panels due to tsunami	(3) Submergence of 6.9 kV high pressure power supply panels
		480V low pressure power supply	X	Function loss due to loss of 6.9 kV high pressure power supply	Submergence of 6.9 kV high pressure power supply panels due to tsunami	Same as (3)
				Function loss due to partial submergence	Partial submergence of 480V low pressure power supply panels due to tsunami	(4) Submergence of 480V low pressure power supply panels
	125V DC power supply	X	Function loss due to submergence	Submergence of 125V DC power supply panels due to tsunami	(5) Submergence of 125V DC power supply panels	
	Alternative power supply function	Power supply interchange (AM)	X	Power supply interchange unavailable from adjacent plants	Loss of station power of adjacent plant (Unit 1) due to tsunami	(6) Submergence of power supply panels of the adjacent plant
		Power source car (emergency arrangement)	X	Difficulty in reaching	Difficulty in reaching due to damaged roads and traffic jams	(7) No deployment of alternative power supply
				Difficulty in connection work	Difficulty in laying cables (weight, isolation, work environment) Intermittent aftershocks and continuous issue of large tsunami warnings	(8) Alternative power supply cable laying -
				Power supply interruption	Loss of communication means due to loss of AC power supply	(9) Communication means at a loss of AC power supply
					Cables damaged and power supply car stopped automatically due to explosion in the Unit 1 Reactor Building	-
	Auxiliary cooling function	Emergency diesel generator facility and cooling seawater system	X	Function loss due to submergence	Submergence of seawater pump for cooling the emergency diesel generator due to the tsunami	(10) Submergence of cooling seawater system for emergency diesel generator
				Function loss due to loss of AC power supply	Submergence of 6.9 kV high pressure power supply panels due to tsunami	Same as (3)
		Seawater system for residual heat removal system	X	Function loss due to submergence	Submergence of seawater pump for cooling the residual heat removal system due to the tsunami	(11) Submergence of seawater pump of the residual heat removal system
				Function loss due to loss of AC power supply	Submergence of 6.9 kV high pressure power supply panels due to tsunami	Same as (3)
		Cooling sea water system	X	Function loss due to submergence	Submergence of cooling seawater pump due to the tsunami	(12) Submergence of cooling seawater pump
				Function loss due to loss of AC power supply	Submergence of 6.9 kV high pressure power supply panels due to tsunami	Same as (3)
				Function loss due to loss of DC power supply	Submergence of 125V DC power supply panels due to tsunami	Same as (5)
	Reactor component cooling water system	X	Function loss due to loss of component cooling seawater system	Submergence of cooling seawater pump due to the tsunami	Same as (12)	
			Function loss due to loss of AC power supply	Submergence of 6.9 kV high pressure power supply panels due to tsunami	Same as (3)	
			Function loss due to loss of DC power supply	Submergence of 125V DC power supply panels due to tsunami	Same as (5)	
Cool down	Function to prevent over-pressurization of reactor coolant pressure boundary	Main steam relief safety valve (safety valve function)	○ (Normal operation)	-	-	
	High pressure core cooling function	High pressure coolant injection system	X	Function loss due to loss of DC power supply	Submergence of 125V DC power supply panels due to tsunami	Same as (5)
		Reactor core isolation cooling system	△ (Operational for approx. 3 days)	Unable to control due to loss of DC power supply	Submergence of 125V DC power supply panels due to tsunami	Same as (5)
	Alternative injection function (high pressure)	Boric acid water injection system (AM)	X	Function loss due to loss of AC power supply	Submergence of 6.9 kV high pressure power supply panels due to tsunami	Same as (3)
				Power supply interruption	[Recovery not possible] Cables damaged and power supply car stopped automatically due to explosion in the Unit 1 Reactor	-
		Control rod drive water system (AM)	X	Function loss due to loss of AC power supply	Unable to receive power due to loss of external power supply and unavailability of emergency diesel generator	Same as (1) - (3)
		Function loss due to loss of component cooling seawater system		Submergence of cooling seawater pump due to the tsunami	Same as (12)	
	Reactor depressurization function	Main steam relief safety valve (relief valve function / automatic depressurization function)	X	Power supply interruption	[Recovery not possible] Cables damaged and power supply car stopped automatically due to explosion in the Unit 1 Reactor	-
				Function loss due to loss of DC power supply	Submergence of 125V DC power supply panels due to tsunami	Same as (5)
		Automatic depressurization	X	Difficulty in depressurizing	Deterioration of the steam condensing performance due to rise of pressure and temperature in the pressure suppression Insufficient voltage in temporarily installed batteries	- -
	Low pressure core cooling function	Core spray system	X	Function loss due to loss of DC power supply	Submergence of 125V DC power supply panels due to tsunami	Same as (5)
				Injection disabled as reactor depressurization function cannot be used	Submergence of 125V DC power supply panels due to tsunami	Same as (5)
				Function loss due to loss of AC power supply	Submergence of 6.9 kV high pressure power supply panels due to tsunami	Same as (3)
Function loss due to loss of DC power supply				Submergence of 125V DC power supply panels due to tsunami	Same as (5)	
			Function loss due to loss of seawater system of residual heat removal system	Submergence of seawater pump for cooling the residual heat removal system due to the tsunami	Same as (11)	

Table 3.3-2 Analysis of cause of the accident at Fukushima Daiichi Nuclear Power Station Unit 2 and Sorting of the problems (2/2)

Safety function	Related facility, etc.	Function loss or function degradation	Cause analysis	Problem			
Low pressure core cooling function	Residual heat removal system (low pressure coolant injection system)	X	Injection disabled as reactor depressurization function cannot be used	Submergence of 125V DC power supply panels due to tsunami	Same as (5)		
			Function loss due to loss of AC power supply	Submergence of 6.9 kV high pressure power supply panels due to tsunami	Same as (3)		
			Function loss due to loss of seawater system of residual heat removal system	Submergence of seawater pump for cooling the residual heat removal system due to the tsunami	Same as (11)		
	Alternative injection function (low pressure)	Makeup water system (AM)	X	Injection disabled as reactor depressurization function cannot be used	Submergence of 125V DC power supply panels due to tsunami	Same as (5)	
				Function loss due to loss of AC power supply	Submergence of 6.9 kV high pressure power supply panels due to tsunami	Same as (3)	
		Fire protection system (AM)	X	Injection disabled as reactor depressurization function cannot be used	Submergence of 125V DC power supply panels due to tsunami	Same as (5)	
				Unable to use the diesel driven extinguishing pump (presumed)	Cause unknown	-	
		Fire engine (Chuetsu coast earthquake response)	△ (insufficient flow rate, difficulty in working)		Injection disabled as reactor depressurization function cannot be used	Submergence of 125V DC power supply panels due to tsunami	Same as (5)
					Difficulty in ensuring the required coolant injection flow rate	Difficulty in ensuring the capacity of the fire protection water tank used as the water source	(13) Depletion of fresh water source
					Difficulty in working	Obstacles due to the impact of the earthquake and tsunami	(14) Obstacles due to the earthquake and tsunami
						Site evacuation due to explosion in the Unit 3 Reactor Building and high radiation dose	(15) Deterioration in work environment due to hydrogen explosion and rise in radiation dose
						[Recovery not possible] seawater injection hose damaged due to explosion in the Unit 3 Reactor Building → relaying	Same as (15)
		Intermittent aftershocks and continuous issue of large tsunami warnings	-				
		Loss of communication means due to loss of AC power supply	Same as (8)				
		Interruption in coolant injection because of no fuel	(16) Fuel supply for fire engine				
Block up	Containment isolation	Main steam isolation valve	○	(Normal operation)	-		
	Function for removing heat from containment vessel	Residual heat removal system	X	Function loss due to loss of AC power supply	Submergence of 6.9 kV high pressure power supply panels due to tsunami	Same as (3)	
				Function loss due to loss of seawater pumping function of residual heat removal system	Submergence of seawater pump for cooling the residual heat removal system due to the tsunami	Same as (10)	
	Alternative heat removal function	Alternative containment vessel spray with makeup water	X	Function loss due to loss of AC power supply	Submergence of 6.9 kV high pressure power supply panels due to tsunami	Same as (3)	
				Unable to use electric pump due to loss of external power supply	2L receiving circuit breaker of Okuma Line in the switchyard of Unit 1/2 damaged due to the earthquake	Same as (1)	
		Alternative containment vessel spray with fire protection system (AM)	X		Unable to use the diesel driven extinguishing pump (presumed)	Cause unknown	-
						Submergence of 125V DC power supply panels due to tsunami	Same as (5)
		Pressure withstanding reinforced vent (AM)	X	Vent unavailable		Drop in pressure of Instrument Air due to loss of external power	(17) Difficulty in ensuring compressed air
						Difficulty in accessing due to rise in radiation dose	Same as (15)
						Loss of communication means due to loss of AC power supply	Same as (8)
						Large valves on suppression pool side closed due to explosion in the Unit 3 Reactor Building	-
					[Recovery not possible] Large valves on suppression pool side closed due to insufficient compressed air	Same as (17)	
	Drywell cooler (AM)	X		[Recovery not possible] Large valves on suppression pool side closed due to malfunction of electromagnetic valve (presumed)	-		
				Reconfiguration of system due to rise in drywell pressure and non-uniform pressure in pressure suppression chamber	-		
	Reactor coolant cleanup system (AM)	X		Inoperative rupture disk	(18) Inoperative rupture disk		
			Function loss due to loss of AC power supply	Unable to receive power due to loss of external power supply and unavailability of emergency diesel generator	Same as (1) - (3)		
			Function loss due to loss of component cooling seawater system	Submergence of cooling seawater pump due to the tsunami	Same as (11)		
Radiation release reduction function	Stand-by gas treatment system	X	Function loss due to loss of AC power supply	Unable to receive power due to loss of external power supply and unavailability of emergency diesel generator	Same as (1) - (3)		
			Unable to operate due to loss of DC power supply	Submergence of 6.9 kV high pressure power supply panels due to tsunami	Same as (3)		
Other	Containment vessel	X	Leakage generation	Pressure drop (cause unknown)	-		
		△	Blow out panel opening (no damage to the building)	Hydrogen retention prevention	-		
Other	Important functions related to safety	Air heating and ventilating system in central control room	X	Function loss due to loss of AC power supply	Submergence of 6.9 kV high pressure power supply panels due to tsunami	Same as (3)	
				Function loss due to loss of AC power supply	Submergence of 6.9 kV high pressure power supply panels due to tsunami	Same as (3)	
	Function to determine the condition of the plant during an accident	Monitoring instruments at the time of an accident	X	Function loss due to loss of AC power supply	Submergence of 6.9 kV high pressure power supply panels due to tsunami	Same as (3)	
				Function loss due to loss of AC power supply	Submergence of 6.9 kV high pressure power supply panels due to tsunami	Same as (3)	
				Function loss due to loss of DC power supply	Submergence of 125V DC power supply panels due to tsunami	Same as (5)	

○: Normal operation; △: Insufficient operation; X: Unable to operate; -: Operation not required
(Note) AM: Accident management (Severe accident measures)

Table 3.3-3 Analysis of cause of the accident at Fukushima Daiichi Nuclear Power Station Unit 3 and Determining the problems (1/2)

Safety function		Related facility, etc.	Function loss or function degradation		Cause analysis	Problem
Stoppage	Emergency reactor shut-down function	Safety protection system, control rod and control rod drive system	○	(Normal operation when earthquake occurred)	-	-
	Alternative reactivity control	Recirculation pump trip (AM)	-	(Not required as scram was successful)	-	-
		Alternative control rod insertion	-	(Not required as scram was successful)	-	-
	Sub-criticality maintenance function	Boric acid water injection system	-	(Not required as scram was successful)	-	-
Support systems	Power supply function	External power supply	X	Loss of external power supply due to the earthquake	Damage to external substation facilities due to the earthquake	(1) Reliability of switchyard equipment
		Emergency diesel generator	X	Function loss due to submergence	Submergence of emergency diesel generator due to the tsunami	(2) Submergence of the emergency diesel generator
		6.9 kV high pressure power supply	X	Function loss due to submergence	Submergence of 6.9 kV high pressure power supply panels due to tsunami	(3) Submergence of 6.9 kV high pressure power supply panels
		480V low pressure power supply	X	Function loss due to loss of 6.9 kV high pressure power supply	Submergence of 6.9 kV high pressure power supply panels due to tsunami	Same as (3)
				Function loss due to submergence	Submergence of 480V low pressure power supply panels due to tsunami	(4) Submergence of 480V low pressure power supply panels
	125V DC power supply	△ (Will deplete later)	(Normal operation)	Use of DC power supply exceeding the available supply time	(5) Depletion of DC power source	
	Alternative power supply function	Power supply interchange (AM)	X	Power supply interchange unavailable from adjacent plants	Loss of station power of adjacent plant (Unit 4) due to tsunami	(6) Submergence of power supply panels of the adjacent plant
		Power source car (emergency arrangement)	X	Difficulty in reaching	Difficulty in reaching due to damaged roads and traffic jams	(7) Procurement of alternative power supply from outside
				Difficulty in connection work	Unable to connect due to submergence of AC power supply panels	Same as (3), (4)
					Difficulty in laying cables (weight, isolation, work environment)	(8) Alternative power supply cable laying
					Intermittent aftershocks and continuous issue of large tsunami warnings	-
	Power supply interruption		Cables damaged and power supply car stopped automatically due to explosion in the Unit 1 Reactor Building	-		
	Auxiliary cooling function	Emergency diesel generator facility and cooling seawater system	X	Function loss due to submergence	Submergence of seawater pump for cooling the emergency diesel generator due to the tsunami	(10) Submergence of cooling seawater pump for emergency diesel generator
				Function loss due to loss of AC power supply	Submergence of 6.9 kV high pressure power supply panels due to tsunami	Same as (3)
		Seawater system for residual heat removal system	X	Function loss due to submergence	Submergence of seawater pump for cooling the residual heat removal system due to the tsunami	(11) Submergence of seawater pump of the residual heat removal system
				Function loss due to loss of AC power supply	Submergence of 6.9 kV high pressure power supply panels due to tsunami	Same as (3)
		Cooling seawater system	X	Function loss due to submergence	Submergence of cooling seawater pump due to the tsunami	(12) Submergence of component cooling seawater pump
				Function loss due to loss of AC power supply	Submergence of 6.9 kV high pressure power supply panels due to tsunami	Same as (3)
	Reactor component cooling water system	X	Function loss due to loss of component cooling seawater system	Submergence of cooling seawater pump due to the tsunami	Same as (12)	
				Function loss due to loss of AC power supply	Submergence of 6.9 kV high pressure power supply panels due to tsunami	Same as (3)
Cool down	Function to prevent over-pressurization of reactor coolant pressure boundary	Main steam relief safety valve (safety valve function)	○	(Normal operation)	-	-
	High pressure core cooling function	High pressure coolant injection system	△	Function loss due to loss of DC power supply	Use of DC power supply exceeding the available supply time	Same as (5)
		Reactor core isolation cooling	△	Function loss due to loss of DC power supply	Use of DC power supply exceeding the available supply time	Same as (5)
	Alternative injection function (high pressure)	Boric acid water injection system (AM)	X	Function loss due to loss of AC power supply	Submergence of 480V low pressure power supply panels due to tsunami	Same as (4)
				Difficulty in power supply recovery operation	[Recovery not possible] Power supply recovery difficult due to aftershocks and poor working environment	-
		Control rod drive water system (AM)	X	Function loss due to loss of AC power supply	Submergence of 480V low pressure power supply panels due to tsunami	Same as (4)
				Function loss due to loss of component cooling seawater system	Submergence of cooling seawater pump due to the tsunami	Same as (12)
	Reactor depressurization	Main steam relief safety valve	△	Function loss due to loss of DC power supply	Use of DC power supply exceeding the available supply time	Same as (5)
		Automatic depressurization	△	Function loss due to loss of DC power supply	Use of DC power supply exceeding the available supply time	Same as (5)
	Low pressure core cooling function	Core spray system	X	Injection disabled as reactor depressurization function cannot be used	Use of DC power supply exceeding the available supply time	Same as (5)
Function loss due to loss of AC power supply				Submergence of 6.9 kV high pressure power supply panels due to tsunami	Same as (3)	
Residual heat removal system (low pressure coolant injection system)		X	Function loss due to loss of seawater system of residual heat removal system	Submergence of seawater pump for cooling the residual heat removal system due to the tsunami	Same as (5)	
			Function loss due to loss of AC power supply	Submergence of 6.9 kV high pressure power supply panels due to tsunami	Same as (11)	

Table 3.3-3 Analysis of cause of the accident at Fukushima Daiichi Nuclear Power Station Unit 3 and Determining the problems (2/2)

Safety function		Related facility, etc.	Function loss or function degradation		Cause analysis	Problem	
Alternative injection function (low pressure)	Makeup water system (AM)	X	X	Injection disabled as reactor depressurization function cannot be used	Use of DC power supply exceeding the available supply time	Same as (5)	
				Function loss due to loss of AC power supply	Submergence of 480V low pressure power supply panels due to tsunami	Same as (4)	
	Fire protection system (AM)	X	X	Injection disabled as reactor depressurization function cannot be used	Use of DC power supply exceeding the available supply time	Same as (5)	
				Injection disabled as reactor depressurization function cannot be used	Use of DC power supply exceeding the available supply time	Same as (5)	
	Fire engine (Chuetsu coast earthquake response)	△ (insufficient flow rate, delay)	△	Difficulty in coolant injection	Insufficient flow rate of the required coolant injection	Difficulty in ensuring the capacity of the fire protection water tank used as the water source	(14) Depletion of fresh water source
					Obstacles due to the impact of the earthquake and tsunami	(15) Obstacles due to the earthquake and tsunami	
					Site evacuation due to explosion in the Unit 3 Reactor Building and high radiation dose	(16) Deterioration in work environment due to hydrogen explosion and rise in radiation	
					Seawater injection hose damaged due to explosion in the Unit 3 Reactor Building → relaying	Same as (16)	
					Intermittent aftershocks and continuous issue of large tsunami warnings	-	
Loss of communication means due to loss of AC power supply	Same as (9)						
Block up	Containment isolation	Main steam isolation valve	△	Operation (generation of isolation signal related to break before and after the main steam isolation valve closure)	-	-	
	Function for removing heat from containment	Containment vessel cooling system	X	Function loss due to loss of seawater system of residual heat removal system	Submergence of seawater pump for cooling the residual heat removal system due to the tsunami	Same as (11)	
				Function loss due to loss of AC power supply	Submergence of 6.9 kV high pressure power supply panels due to tsunami	Same as (3)	
	Alternative heat removal function	Alternative containment vessel spray with makeup water	X	X	Function loss due to loss of AC power supply	Submergence of 480V low pressure power supply panels due to tsunami	Same as (4)
					Alternative containment vessel spray with fire protection system (AM)	△	Unable to use the electric pump due to loss of power supply. Diesel pump temporarily operational
		Containment vessel vent (AM)	△	△	Difficulty in vent operation	Use of DC power supply exceeding the available supply time	Same as (5)
						Drop in pressure of Instrument Air due to loss of external power supply	Same as (1)
						Difficulty in accessing due to rise in radiation dose	Same as (16)
		Drywell cooler (AM)	X	X	Function loss due to loss of AC power supply	Loss of communication means due to loss of AC power supply	Same as (9)
	Function loss due to loss of component cooling seawater system					High temperature, pitch dark working environment	Same as (4) and (5)
	Reactor coolant cleanup system (AM)	X	X	Function loss due to loss of AC power supply	Submergence of 480V low pressure power supply panels due to tsunami	Same as (4)	
					Function loss due to loss of component cooling seawater system	Submergence of cooling seawater pump due to the tsunami	Same as (11)
	Radioactive material release reduction function	Stand-by gas treatment system	X	X	Unable to operate due to loss of DC power supply	Submergence of 480V low pressure power supply panels due to tsunami	Same as (4)
	Multiple barrier function	Containment vessel	X	X	Leakage generation	Deterioration in the seal of flange gasket and penetration due to loss in the function for removing heat from containment vessel	(17) Heat resistance and pressure resistance of gasket and penetration seal
Hydrogen generation due to the reaction of zircaloy and water					-		
Reactor building		X	X	Damage due to hydrogen explosion	Hydrogen leakage from containment vessel penetration part	-	
	Hydrogen retention in reactor building				(18) Hydrogen retention in reactor building		
Other	Important functions related to safety	Air heating and ventilating system in central control room	X	X	Function loss due to loss of AC power supply	Submergence of 480V low pressure power supply panels due to tsunami	Same as (4)
	Function to determine the condition of the plant during an accident	Monitoring instruments at the time of an accident	X	X	Function loss due to loss of DC power supply	Use of DC power supply exceeding the available supply time	Same as (5)
	Function to determine abnormal conditions	Communication equipment	X	X	Function loss due to loss of AC power supply	Submergence of 480V low pressure power supply panels due to tsunami	Same as (4)
					Function loss due to loss of DC power supply	Submergence of 480V low pressure power supply panels due to tsunami	Same as (4)
Emergency lighting	X	X	Function loss due to loss of AC power supply	Use of DC power supply exceeding the available supply time	Same as (5)		

○: Normal operation; △: Insufficient operation; X: Unable to operate; -: Operation not required
(Note) AM: Accident management (Severe accident measures)

3.3.1.1 Problems by function

(1) “Stopping” function

a. Emergency reactor shut-down function of the reactors

The reactors scrammed normally due to the earthquake. The emergency reactor shut-down function of the reactors has not been lost in the safety protection system and control rod drive system.

b. Sub-criticality maintenance function

Normal scram of the reactors prevented a request of the function for control of alternative reactivity rate (control of reactivity rate by recirculation pump trip and alternative control rod insertion).

However, the recirculation pump tripped due to the loss of external power supply.

c. Sub-criticality maintenance function

Normal scram of the reactors prevented a request of the function for sub-criticality maintenance by SLC.

As mentioned above, since the “stopping” function operated normally or the function was not requested, no cause and no problem exist.

(2) “Cooling” function

a. Function to prevent over-pressurization in the reactor coolant pressure boundary

Signs of the loss of reactor coolant by the earthquake were not found from the maintenance of main steam flow rate or temperature change in the containment air handling system after the earthquake.

In Unit 1, no request was made to perform the safety valve function of SRV because IC controlled the reactor pressure after MSIV was closed.

In Unit 2 and 3, SRV stably controlled the reactor pressure with the relief valve function or safety valve function after MSIV was closed, and performed its function normally.

b. High pressure core cooling function

(a) High pressure coolant injection system

For water levels of reactors after the scram, Units 1 to 3 were not given functional requests for HPCI operation request, but HPCI was put in a standby state. After that, arrival of the tsunami caused Units 1 and 2 to lose their functions due to the loss of 125 V DC power. In Unit 3, since the D.C. power supply system avoided being flooded, RCIC and HPCI could be used. With the reduction of water level in the reactors, the HPCI automatically started and the water level of the reactors was retained for a while. However, it then stopped and the function for injecting coolant into the reactors was lost. This was caused by the DC power supply running out.

(b) Emergency condenser (Unit 1 only)

The high pressure in the reactor automatically started the IC after MSIV was closed. After that, the power was lost due to the tsunami during the reactor pressure control operation by the IC. Since loss of the control power supply (DC power supply) of IC due to the tsunami prevented the workers from confirming the open and closed state of the IC valve, and the indicator lamps of HPCI were off, they judged that startup was impossible. According to an investigation after that, there is a possibility that deenergizing the detection circuit of break in pipe, normally made up of an excitation circuit, could originate an isolation signal, automatically closing the valves of the IC. An almost simultaneous loss of all AC power supplies may have caused the isolation valve inside the reactor containment, driven by AC power supply, to stop closing with the valve half opened (the clear opening is unknown). When the DC power supply was temporarily recovered around 18:00 on March 11 (reason for the recovery is unknown), the isolation valve outside the reactor containment was opened. However, the degree of the IC's core cooling function is unknown according to the opening of the isolation valve outside the reactor containment. There seems to be a high possibility that the IC's function may have been lost until the temporary recovery of the DC power supply after the tsunami arrived.

As a facility for supplying coolant to the IC, FP and called a makeup water system purified (hereafter called "MUWP") is provided. However, loss of the low voltage power supply of 480 V caused it to lose its function. The FP is divided into a motor pump and a diesel pump. The motor pump stopped working due to the loss of AC power supply. It is confirmed that the diesel driven pump ran temporarily but stopped due to a malfunction. The details of the malfunction are unknown.

(c) Reactor core isolation cooling system (Units 2 and 3)

After the scram, manual startup of the RCIC, automatic stop due to increase of reactor water level, and manual startup were repeated to control the reactor water level.

In Unit 2, the operation state of the RCIC was not confirmed. At around 3:00 on March 12, however, the discharge pressure of the RCIC pump was confirmed, and the pump is judged to have been running. After that, the water source was switched from CST to S/C to perform the operation. After 13:00 on March 14, the water level of the reactor tended to decrease, and the function of the RCIC was judged to have stopped working at 13:25. As a result, the RCIC of Unit 2 is considered to have worked for approximately 3 days. It seems that loss of the power supply set the valve of the RCIC to work "as is" and the valve happened to open with the timing of the loss of the power supply.

In Unit 3, since the DC power supply was not affected by the tsunami, the RCIC and HPCI, operable with DC power supply, were usable. Any unnecessary loads were isolated to increase the operating time of the batteries. At 11:36 on March 12, the RCIC automatically stopped and the HPCI automatically started up. At 2:42 on March 13, the HPCI automatically stopped and lost its function to inject coolant into the reactor. As a result, coolant was injected to Unit 3 for approximately 1.5 days until the battery ran out.

c. High pressure alternate injection function (countermeasure for severe accident)

(a) Standby liquid control system

Stopped working due to the loss of the power supplied from the low voltage power supply of 480 V necessary for the operation of the standby liquid control pump in Units 1 to 3. Since the power panel of the standby liquid control system and the main body of the standby liquid control were not affected by the tsunami, power supply operation from the power supply vehicle, arranged urgently after the station blackout, were carried out. However, because the hydrogen explosion in the reactor building of Unit 1 damaged the cable that had been laid, the power supply vehicle arranged urgently stopped automatically, and then the SLC function was not recovered.

(b) Control rod drive water system

Stopped working due to the loss of the power supplied from the low voltage power supply of 480 V necessary for operating the drive water pump in Units 1 to 3.

d. Reactor depressurization function

(a) Main steam relief safety valve (manual relief function and automatic depressurization function)

The manual relief function and automatic depressurization function were lost because Units 1 to 3 lost its power supplied from the 125 V DC power supply necessary for the operation. As the result, the reactor pressure remained high, systems and facilities having the low pressure core cooling function could not inject coolant into the reactors. However, since the systems having a low pressure core cooling function lost their power supplies when all AC power supplies were lost, the function to inject coolant into the reactor stopped working.

Since Unit 2 required the depressurization of the reactor for fire engines to inject coolant to the reactor after the RCIC stopped, temporary batteries were used to ensure the power supply necessary for SRV to operate, so that the reactor was depressurized.

e. Low pressure core cooling function

(a) Core spray system

In Units 1 to 3, the core spray pump stopped working due to the loss of the power supplied from the high voltage power supply of 6.9 kV necessary for the operation of the core spray pump.

(b) Low pressure coolant injection system (residual heat removal system) (Units 2 and 3)

The residual heat removal pump (low pressure coolant injection mode) stopped working due to the loss of the power supplied from the high voltage power supply of 6.9 kV necessary for the operation of the residual heat removal pump.

f. Low pressure alternate injection function (countermeasure for severe accident)

(a) Makeup water system

In Units 1 to 3, the makeup water pump stopped working due to the loss of the power supplied from the low voltage power supply of 480 V necessary for the operation of the makeup water pump.

(b) Fire protection system

The fire protection system pump stopped working due to the loss of the power supplied from the low voltage power supply of 480 V necessary for the operation of the fire protection system pump. In addition to motor-driven system pumps, diesel driven pumps were used as fire protection system pumps. In Unit 1, it is confirmed that they ran temporarily but stopped due to a malfunction. In Unit 2, a startup operation seems not to have been performed. However, the details are unknown, e.g., whether the operation was not done due to a failure. In Unit 3, pumps ran temporarily but then stopped. The details are unknown.

Alternate coolant injection was carried out using fire engines prepared as a countermeasure taken after the Chuetsu Offshore Earthquake. However, the volume of the fire protection tank used as a water source was limited, so the required volume of coolant was insufficient. Therefore, workers prepared to inject seawater. Operations for the injection of coolant into the reactors had difficulties caused factors such as obstacles produced by impact of the earthquake and tsunami, evacuation from the field site due to explosion of the reactor building of Unit 1, high-dose debris, relaying of seawater injection hoses replaced with damaged ones, consecutive aftershocks, continuation of large tsunami warning, and loss of communication methods due to the loss of AC power supply. In Unit 2, fire engines started injecting seawater after the reactor depressurization. However, since they ran out of fuel and stopped, injection of coolant to the reactor was suspended.

(c) Containment & vessel cooling water system

The containment & vessel cooling water pump (Units 2 and 3 was put in the containment & vessel cooling mode for RHR pump) stopped working, because the power supplied from the high voltage power supply of

6.9 kV and the 125 V DC power supply necessary for the operation on the containment & vessel cooling water pump were unavailable or because the pump could not be started up due to flooding of the containment & vessel cooling seawater system (residual heat removal cooling seawater system in Units 2 and 3) and loss of the power supply.

For the reasons above, problems with the “cooling” function by facility are as follows.

- Submergence of power supply systems
- Exhaustion of seawater pump
- Exhaustion of fresh-water source

- Deterioration of working environments due to hydrogen explosion and increase of radiation dosage
- Obstacles caused by the earthquake and tsunami
- Loss of communication methods during loss of AC power supply
- Refueling of fire engines
- Exhaustion of DC power supply
- Origination of IC isolation signal with DC power supply lost

(3) “Confining” function

a. Reactor containment isolation function

For Units 1 to 3, the MSIV is normally closed by the isolation signal generated due to the loss of external power supply after the earthquake. No leakage occurs in the main steam piping because the flow rate of main steam is zero after the MSIV is closed and because the reactor pressure has been increased.

The reactor containment isolation function works normally immediately after the occurrence of a scram, and there are no causes of accidents or problems.

b. Heat removal function from the containment

CCS (Unit 1: CCS, Units 2 and 3: RHR containment cooling mode) started up manually after the scram, and Units 1 and 2 started up manually to cool the water in the S/C pool. After that, the CCS pump stopped working due to the loss of the power supplied from the high voltage power supply of 6.9 kV necessary for the operation of the CCS pump. Unit 3 did not start up due to the loss of power supply.

c. Alternative cooling function (facilities for countermeasures for severe accident)

(a) Alternative containment spray by the makeup water system

The makeup water system pump stopped working due to the loss of the power supplied from the low voltage power supply of 480 V necessary for the operation of the makeup water system pump.

(b) Alternative containment spray by the fire protection system

The fire protection pump stopped working due to the loss of the power supplied from the low voltage power supply of 480 V necessary for the operation of the fire protection pump. In addition to motor-driven system pumps, diesel driven pumps were used as fire protection system pumps. For the situation, refer to the description in f. “**Low pressure alternate injection function (countermeasure for severe accident).**”

(c) Containment vessel pressure reinforcement vent

The vent to be performed based on the primary operation procedure could not be done because no power was supplied from 125 V DC power supplies necessary for the operation and the air pressure for instrumentation was decreased.

For Units 1 and 3, the workers tried to perform a manual release operation. However, the operations had difficulties because access was

difficult caused by increase of radiation dosage or by loss of communication methods due to the loss of AC power supply. As a result, vent is considered to have been made because the pressure of the containment was decreased.

In Unit 1, when operations for opening vent valves of S/C (small valve) were performed several times in expectation of residual pressure of compressed air for instrumentation, the indication value of MP increased. Immediately after that, the indicated value of MP radiation dosage decreased. It was therefore confirmed that there was a possibility that the vent might not be effective. The cause of this is assumed to be that the vent valves of the containment were closed immediately because the residual air pressure for instrumentation was low and the valves could not be kept open. Considering the vent of the containment of Unit 1 to take precedence over that of the other reactors, the Minister of Economy, Trade and Industry issued an order to vent it at 6:50 on March 12. After the Prime Minister's visit to Okuma Town (Kuma area), confirmation of evacuation and such like, the reactor was vented at 9:15.

Although Unit 3 also had difficulties in operation, the Station judged that the venting had been done. After that, since the air pressure and power supplies were not retained, valve opening operations were conducted several times.

In Unit 2, the pressure of S/C remained lower than the working pressure of the rupture disk. On the other hand, the release operation was carried out for line configuration because the pressure of D/W was increasing. However, the pressure of D/W decreased around 6:00. For the reasons above, the implementation state of venting the containment of Unit 2 is not clear at the current stage.

The pressure of D/W increased, while the pressure of S/C decreased. However, the factors causing such behavior are unknown at the current stage.

(d) Alternative heat removal (countermeasure for severe accident) by dry well cooler and reactor coolant cleanup system

In each case, the function was lost because the power was not supplied from the low voltage power supply of 480 V and the reactor component cooling water system stopped.

d. Function for reducing the discharge of radioactive materials

The SGTS stopped working because the power was not supplied from the low voltage power supply of 480 V.

e. Others

For the primary containment vessel (hereinafter referred to as "PCV"), it is suspected that the heat removal function from the containment vessel was lost and the containment atmosphere was overheated and over-pressurized, causing the seal of flange gaskets and penetrations to deteriorate and causing a leakage to occur. It is conjectured that hydrogen leaking from penetrations of the containment vessel collected in the reactor building and the hydrogen concentration rose exceeding the flammability limit, thus causing a hydrogen explosion to occur.

In terms of the leakage route from the PCV, hydrogen may also have leaked from the isolation valve between the vent line and ventilation and air conditioning system at the time of PCV pressure venting, causing hydrogen to spread in the building through the ventilation system.

For the reactor building for Unit 2, it is also conjectured that hydrogen did not collect in one place because the blow-out panel was open.

For the reasons above, problems on the “confining” function by facility are as follows.

- Submergence of power supply systems
- Submergence of seawater pump
- Deterioration of working environments due to hydrogen explosion/ increase of radiation dosage
- Sealing property in a state exceeding the design conditions of gasket and seal of the penetration
- Retention of hydrogen in the reactor building
- Assurance of compressed air to keep the vent valves of the containment open
- Non-operation of rupture disk for venting the containment at low pressures
- leaked from the containment vessel pressure reinforcement vent isolation valve line and air conditioning system.

(4) Basic requirements for implementing the operation (facility environments)

a. Habitability of the Main Control Room

When the accident occurred, the air heating and ventilating system to ensure the habitability of the MCR stopped working because the power was not supplied from the low voltage power supply of 480 V.

b. Function of seizing the status of the station at the time of an accident

The monitoring instruments, which work to determine the status of the station at the time of an accident, stopped working, because DC power for instrumentation was not supplied to Unit 1 and the power from the low voltage power supply of 480 V was not supplied to Units 2 and 3.

c. Functions of seizing an abnormal state

Communication equipment and emergency lighting, which were functions to determine abnormal states, stopped working, because power was supplied neither from the low voltage power supply of 480 V nor 125 V DC power supply.

For the reasons above, the following items are listed as the basic requirements for implementing the operation (facility environments).

- Submergence of power supply systems
- Exhaustion of DC power supply

3.3.1.2 Problems related to common factors and failures

Extracted problems by function in 3.3.1.1 include “without power supplied from power supply system” and “stoppage of cooling water system.” Therefore, analysis of the causes and extraction of problems were furthermore carried out in terms of “power supply function” and “auxiliary component cooling function.”

(1) Power supply function

a. External power source

All Units 1 to 4 receive power supplied from external power sources via the Shin-Fukushima Substation. The power supplies were lost caused by factors including damage to facilities in the substation due to the earthquake, damage to power receiving breakers and disconnecting switches within the switchyard of the station due to the earthquake, and operations of protective devices due to the power transmission lines coming into contact with steel towers due to the earthquake. In addition to the damage due to the earthquake, it became difficult for the workers to recover external power supplies to the switchyards for Units 3 and 4 at an early date because they were flooded by the tsunami.

b. Emergency diesel generator

After the loss of the external power supplies, Units 1 to 3 automatically started up emergency DGs to supply power to the emergency bus. After that, however, the tsunami flooded them (although the main unit of 2BDG escaped the tsunami-caused damage, the high voltage power panel of 6.9 kV was flooded), they stopped working, and the reactors then lost all AC power supplies.

c. On-site power

The high voltage power supply of 6.9 kV stopped working because the power panel was flooded. Therefore, the low voltage power supply of 480 V, used as the load, also stopped working. The 480 V power panels for Units 1 and 3 were also flooded.

The 125 V DC power for Units 1 and 2 could not be supplied from batteries, because the 125 V DC power panel was flooded by the tsunami. The 125 V DC power panel for Unit 3 escaped the flood. After the batteries worked for several days, they became exhausted and stopped working.

d. Alternative power supply function

The station blackout prevented the power interchange from adjacent reactors, which had been prepared as a countermeasure for severe accidents.

Operations for laying and connecting cables were extremely difficult for various reasons, e.g., delay in arrival of power supply vehicles arranged urgently after the station blackout due to damage to roads caused by the earthquake and traffic congestions, submergence of all AC power panels, weight of cables, laying distance, poor working conditions, intermittent aftershocks, continuation of large tsunami warning, and loss of communication methods. In addition, the hydrogen explosion in the reactor building damaged the laid cables, and the power supply vehicles stopped automatically.

For the reasons above, problems on power supply functions by facility are listed as follows.

- Reliability of external power supplies against earthquakes and tsunami
- Reliability of breakers in switchyards when earthquakes occur
- Submergence of power supply systems
- Procurement of alternative power supplies from outside
- Laying of cables for alternative power supplies
- Communication methods during the loss of AC power supply

(2) Auxiliary component cooling function

Immediately after the external power supplies were lost due to the earthquake, the seawater systems requiring the auxiliary component cooling function received power from the emergency DG and operated normally. However, since the seawater pump was flooded due to the tsunami, and the high voltage power panel of 6.9 kV for supply power was flooded, the function was lost.

For the reasons above, problems on the auxiliary component cooling function by facility are listed as follows.

- Submergence of seawater pump
- Submergence of power supply systems

Electric power systems and auxiliary component cooling systems are facilities having highly important safety functions. Since all the systems stopped working at once due to the tsunami, the accident escalated. The facilities of countermeasures against severe accidents, which were prepared for multifailure, could not stop the accident from expanding, because they stopped working due to the loss of electric power systems and auxiliary component cooling systems.

For the reasons above, the following problems can be listed as countermeasures against severe accidents for power supply systems and auxiliary component cooling systems.

- Prevention of tsunami from damaging all facilities at once.
- Means of preventing tsunami from affecting items (breakwater, or deployment in rising ground, etc.) have been prepared so that damage by tsunami can be avoided.

3.4 Causal analysis of the accident at Unit 4 and management of issues

The causes of the loss of cooling function of the spent fuel pool and the hydrogen explosion in Fukushima Daiichi Unit 4 are summarized. The result of the causal analysis of the accident in Unit 4 and the management of the issues are shown in Table 3.4-1.

After the earthquake occurred, there was a loss of an external power supply, and a station blackout, which was caused by a loss of emergency DG due to the tsunami. The DC power supply and a seawater pump were also lost.

Table 3.4-1 Analysis of cause of the accident at Fukushima Daiichi Nuclear Power Station Unit 4 and Determining the problems (1/1)

Safety function	Related facility, etc.	Function loss or function degradation	Cause analysis	Problem			
Support systems	Power supply function	External power supply	X	Loss of external power supply due to the earthquake	(1) Reliability of switchyard equipment		
		Emergency diesel generator	X	1 out of the 2 installed generators is under routine inspection. The remaining generator cannot be used as the power supply panels are submerged (the emergency diesel generator is not submerged in operation)	(2) Submergence of 6.9 kV high pressure power supply panels		
		6.9 kV high pressure power supply	X	Function loss due to submergence	Submergence of 6.9 kV high pressure power supply panel: due to tsunami	Same as (2)	
		480 V low pressure power supply	X	Function loss due to submergence (only power supply panels installed in auxiliary public facilities in operation)	Submergence of 480 V low pressure power supply panels due to tsunami	(3) Submergence of 480 V low pressure power supply panels	
		125V DC power supply	X	Function loss due to submergence	Submergence of 125V DC power supply panels due to tsunami	(4) Submergence of 125V DC power supply panels	
	Auxiliary cooling function	Seawater system for residual heat removal system	X	Function loss due to submergence	Submergence of seawater pump for cooling the residual heat removal system due to the tsunami	(5) Submergence of seawater pump of the residual heat removal system	
				Function loss due to loss of AC power supply	Submergence of 6.9 kV high pressure power supply panel: due to tsunami	Same as (2)	
		seawater cooling system	X	Function loss due to submergence	Submergence of cooling seawater pump due to the tsunami	(6) Submergence of component cooling seawater pump	
				Function loss due to loss of AC power supply	Submergence of 6.9 kV high pressure power supply panel: due to tsunami	Same as (2)	
			X	Function loss due to loss of component cooling seawater system	Submergence of cooling seawater pump due to the tsunami	Same as (6)	
	Cooling of spent fuel pools	Cooling function	Fuel pool cooling system	X	Function loss due to loss of AC power supply	Submergence of 6.9 kV high pressure power supply panel: and 480 V low pressure power supply panels due to tsunami	Same as (3), (4)
			Residual heat removal system	X	Function loss due to loss of seawater system of residual heat removal system	Submergence of seawater pump for cooling the residual heat removal system due to the tsunami	Same as (5)
Coolant injection		Makeup water supply system	X	Function loss due to loss of AC power supply	Submergence of 6.9 kV high pressure power supply panel: due to tsunami	Same as (2)	
Block up	Secondary containment vessel	Reactor building	X	Damage due to hydrogen explosion	Hydrogen retention in reactor building	(7) Hydrogen retention in reactor building	
					Inflow of vent gas in Unit 3	(8) Wraparound of hydrogen gas in units that share the vent stack	

○: Normal operation; △: Insufficient operation; X: Unable to operate; -: Operation not

(1) Loss of cooling function of the spent fuel pool

a. Spent fuel pool cooling function

The FPC, which had been operating right before the earthquake, stopped because the external power supply was lost due to the earthquake. After that, the SFP cooling function was lost because the function of the component cooling water system was lost due to the tsunami and the 480 V low voltage power supply that is necessary for the operation of the FPC was lost.

The RHR, which had been operating right before the earthquake, stopped because the external power supply was lost due to the earthquake. After that, the SFP cooling function was lost because the function of the RHR seawater system was lost due to the tsunami and the 6.9 kV high voltage power supply that is necessary for the operation of the RHR was lost.

The MUWC has a function of supplying water to the SFP. However, it stopped working because the 480 V low voltage power supply that is necessary for the operation of the MUWC was lost.

As a result, the issues of the respective facility regarding the SFP cooling function were as follows.

- Soaking of the seawater pump
- Soaking of the power supply facility

(2) Hydrogen explosion

a. Main cause of hydrogen generation

An explosion that is considered to be due to hydrogen occurred in the reactor building of Unit 4 at about 6:00 on March 15.

When the earthquake occurred, Unit 4 had been stopped because it was undergoing a periodic inspection, and all fuel was taken out from the reactor to the spent fuel pool. Because of this, there was no possibility of hydrogen generation from the reactor. As a result of observing the fuel in the pool with a camera, it can be assumed that no damage to the fuel was found, and that there was no large-scale damage of the fuel from the result of analyzing nuclides of the fuel pool water taken from the fuel pool of Unit 4. Consequently, the possibility of a large amount of hydrogen being generated in the fuel pool of Unit 4 was low.

On the other hand, the SGTS exhaust pipe of Unit 4 joined with the SGTS exhaust pipe of Unit 3 before the vent stack. There is a possibility that the hydrogen explosion occurred as a result of the hydrogen in the PCV of Unit 3 flowing into the R/B of Unit 4 through the SGTS exhaust pipe via a container vent that was carried out in Unit 3, and the hydrogen was retained. The radiation dose of the SGTS filter train of Unit 4 was measured, and it was found that the radiation dose was high on the exit side and got lower going toward the entrance side.

As a result, the issues of the respective facility regarding the hydrogen explosion in Unit 4 are as follows.

- Hydrogen retention in the reactor building
- Wrapping around of hydrogen gas between the units that share the vent stack

- Wrapping around from the container vent line to the building

3.5 Management of events at Units 5 and 6

Because the reactors of Units 5 and 6 were not working and there was enough time for correspondence, the power supply was successfully accommodated from the DG (6B) whose function was not lost due to the tsunami and alternative coolant injection was successful. Conclusively, the residual heat removal function by the temporary seawater pump was able to recover.

The course of the events of Fukushima Daiichi Units 5 and 6 is shown in Figure 3.5-1 using an event tree.

The workers successfully prevented accidents from escalating in Units 5 and 6 by directly connecting a power supply of one air-cooled emergency DG to a safety component. It is considered that safety can be ensured when the power supply is secure.

Hence, having a variety of cooling types of the emergency DG and having a variety of installation sites from the viewpoint of soaking can become effective countermeasures.

However, it should be kept in mind that there was a need to supply power by directly drawing a cable from a bus of the emergency DG to the safety component because the power panel was affected by the tsunami. Because the distribution of electricity to multiple safety components will be simultaneously lost when the power panel is submerged, it is necessary to investigate a plan for supplying power to the necessary components from the available power supplies even when soaking occurs, while ensuring soaking countermeasures in order to increase the security of the dependable power supply.

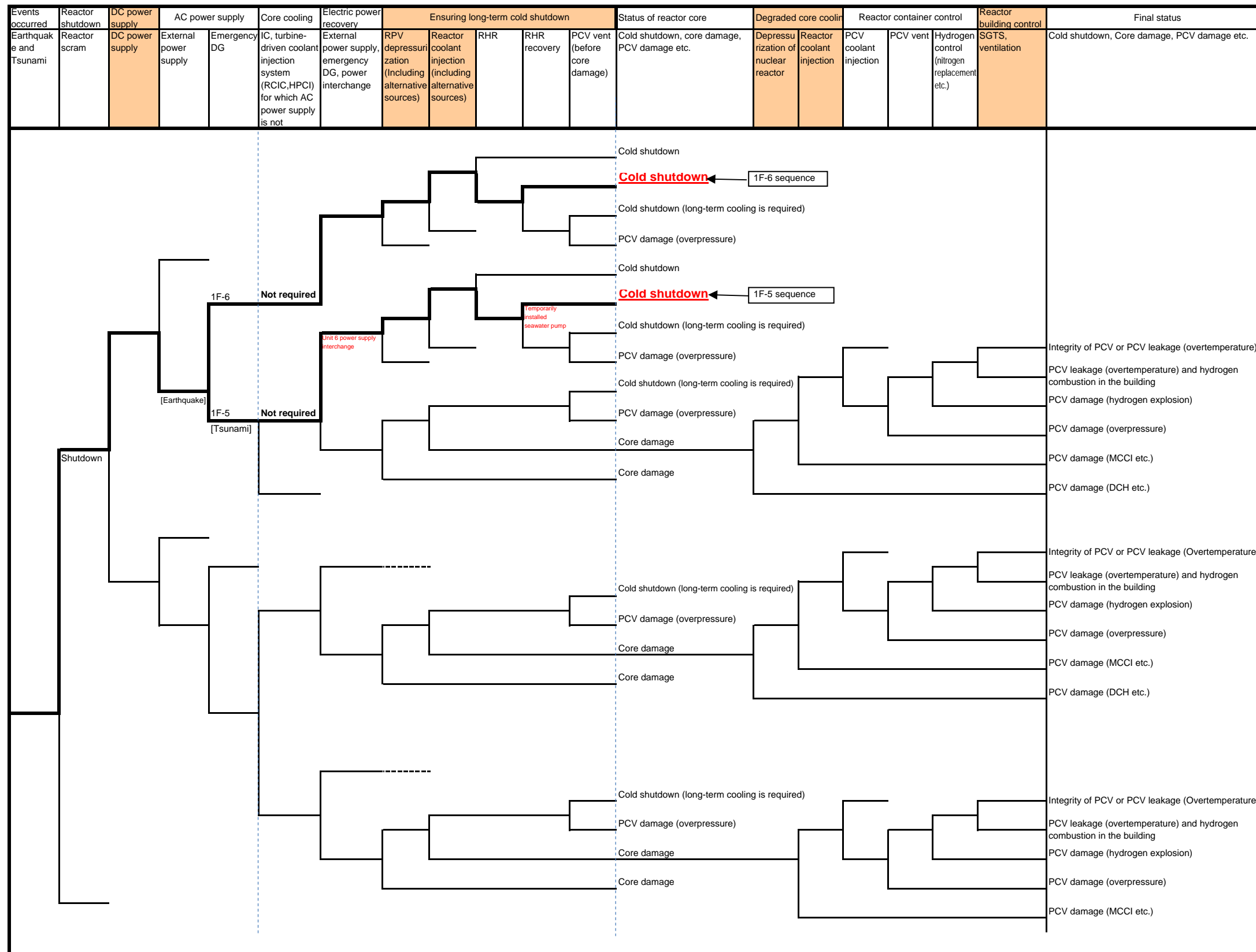

Figure 3.5-1 Disaster identification events tree in Fukushima Daiichi Nuclear Power Station Units 5, 6

(1) Unit 5

Refer to “2.6 Course of accident at Unit 5” in this article for the behavior of the plant when the earthquake occurred.

a. Status of “stopping” function

When the earthquake occurred, Unit 5 had been stopped because it was undergoing a periodic inspection, the pressure of the reactor was increased and maintained to 7.2 MPa for a pressure resistance and leakage inspection, and control rods were fully inserted

b. Status of “cooling” function

All AC power source was lost due to the tsunami, and the operations of the RHR, the low pressure core spray, and the HPCS became impossible. The pressure of the RPV was reduced a day after the earthquake by opening a valve at the top of the RPV.

On March 13, the pressure and the water level of the reactor were controlled by starting a condensate water transfer pump using the power supply that was exchanged from Unit 6, by properly reducing the pressure with the SRV, and at the same time by repeating an operation of supplying water from the CST to the reactor with the condensate water transfer pump.

Then, both the spent fuel pool and the reactor were cooled by building a temporary seawater pump to take seawater and by alternating cooling of the spent fuel pool and the reactor by switching system configurations of the RHR.

c. Status of “confining” function

A stable value was shown for the stack radiation monitor, and no abnormality was found.

d. Status of the spent fuel pool cooling system

The water level of the spent fuel pool was full and the water temperature of the pool was about 24°C before the earthquake, and it was not a condition in which cooling of the fuel was impeded during an early stage. Therefore, the pool had not been cooled before the tsunami arrived. Because all AC power was lost due to the tsunami, the RHR became unusable. Then, both the spent fuel pool and the reactor were alternately cooled by building a temporary seawater pump to take seawater and by switching system configurations of the RHR.

e. Status of “power supply” function

Because the external power supply was lost due to the earthquake, two emergency DGs were automatically started. Although all AC power was lost due to the tsunami, one diesel generator continued to operate in Unit 6 and power that is necessary to accommodate the power source to Unit 5 was supplied.

(2) Unit 6

Refer to “2.7 Course of accident at Unit 6” in this article for the behavior of the plant when the earthquake occurred.

a. Status of “stopping” function

When the earthquake occurred, Unit 6 had been stopped because it was undergoing a periodic inspection, and the RPV top head was tightened with a bolt. The reactor was in a status of cold shutdown, and all control rods were inserted.

b. Status of “cooling” function

The reactor was in a status of cold shutdown before the earthquake, and it was not a condition in which cooling of the fuel is impeded during the early stage. Therefore, the pool had not been cooled when the reactor was stopped before the tsunami arrived.

The function of two diesel generators was lost due to the influence of the tsunami, and the RHR, the low pressure core spray system, and the HPCS became unusable because power supply was lost and the seawater pump was unavailable. On the other hand, one diesel generator continued to operate and power that is necessary to maintain the function of supplying water to the reactor was supplied. The pressure and the water level of the reactor were controlled by starting a condensate water transfer pump on March 13, by properly reducing the pressure with the SRV, and at the same time by repeating an operation of supplying water from the CST to the reactor on and after March 14.

Then, both the spent fuel pool and the reactor were cooled by building a temporary seawater pump to take seawater and by alternating cooling of the spent fuel pool and the reactor by switching system configurations of the RHR.

c. Status of “confining” function

A stable value was shown for the stack radiation monitor, and no abnormality was found.

d. Status of the spent fuel pool cooling system

The water level of the spent fuel pool was full and the water temperature of the pool was about 25°C before the earthquake, and it was not a condition in which cooling of the fuel was impeded during the early stage. Therefore, the pool had not been cooled before the tsunami arrived. Because two diesel generators were lost due to the tsunami, the RHR became unusable. Then, both of the spent fuel pool and the reactor were alternately cooled by building a temporary seawater pump to take seawater and by switching system configurations of the RHR.

e. Status of “power supply” function

Because the external power supply was lost due to the earthquake, three emergency DGs were automatically started. Although the function of two diesel generators was lost due to the tsunami, one diesel generator continued to operate and power that is necessary to accommodate the power source to the reactor for cooling and to Unit 5 was supplied.

3.6 Comparison of course of events at Fukushima Daiichi Nuclear Power Station with other stations

In the accident at this time, a large amount of radioactive material was discharged from Fukushima Daiichi Nuclear Power Station (Fukushima Daiichi) into the environment. However, we decided to learn a lesson also by comparing a station that ended up discharging radioactive materials with a station that did not discharge any even though the tsunami hit. Fukushima Daini Nuclear Power Station, Onagawa Nuclear Power Station (hereafter called “Onagawa”), and Tokai Daini Nuclear Power S (hereafter called “Tokai Daini”) were affected by the tsunami. They have been selected as stations that did not discharge radioactive materials, and we investigated and compared Fukushima Daiichi Units 1 to 3 with these stations.

As shown in Fig. 3.6-1, the course of events in Fukushima Daiichi Units 1 to 3 and other stations differ from the heading of the AC power supply (the external power supply or the emergency DG), and the power supply was secured in all the other stations as a result, which prevented the accident from escalating.

Hence, we found that the main cause of the escalation of the accident in Fukushima Daiichi is that the external power supply and the emergency DG were lost due to the earthquake and the tsunami and all of the safety components and the facilities to counter severe accidents could not function excluding some of the components that did not need a power supply.

As shown in Table 3.6-1, the main reason that the power supply was secured in other stations is considered to be that the tsunami did not reach their sites. The tsunami did infiltrate the site of Fukushima Daini, and the external power supply, the power panel, the emergency DG, and such like were damaged. However, the accident was resolved by using a power supply and facility that were not damaged because the infiltration of the tsunami was limited.

The core cooling and the ultimate heat sink can become a common cause of making it impossible to remove decay heat and can cause the accident to escalate. The core cooling by the RCIC and the HPCS was possible in Fukushima Daini, Onagawa, and Tokai Daini, and cooling of the reactor by the core cooling system was sufficiently effective as long as the power supply could be secured.

Ultimately, cooling by the RHR was secured and the event was settled in all of the above described stations. In the case of Tokai Daini, tsunami countermeasures were taken in the seawater pump area for the seawater system pertaining to the ultimate heat sink. When the components in which the countermeasures had already been taken operated, a smooth settlement of the event became possible. Hence, the importance of tsunami countermeasures for the seawater system (soaking prevention countermeasures) can be seen.

Details of the investigation of each station are attached as Appendix 1.

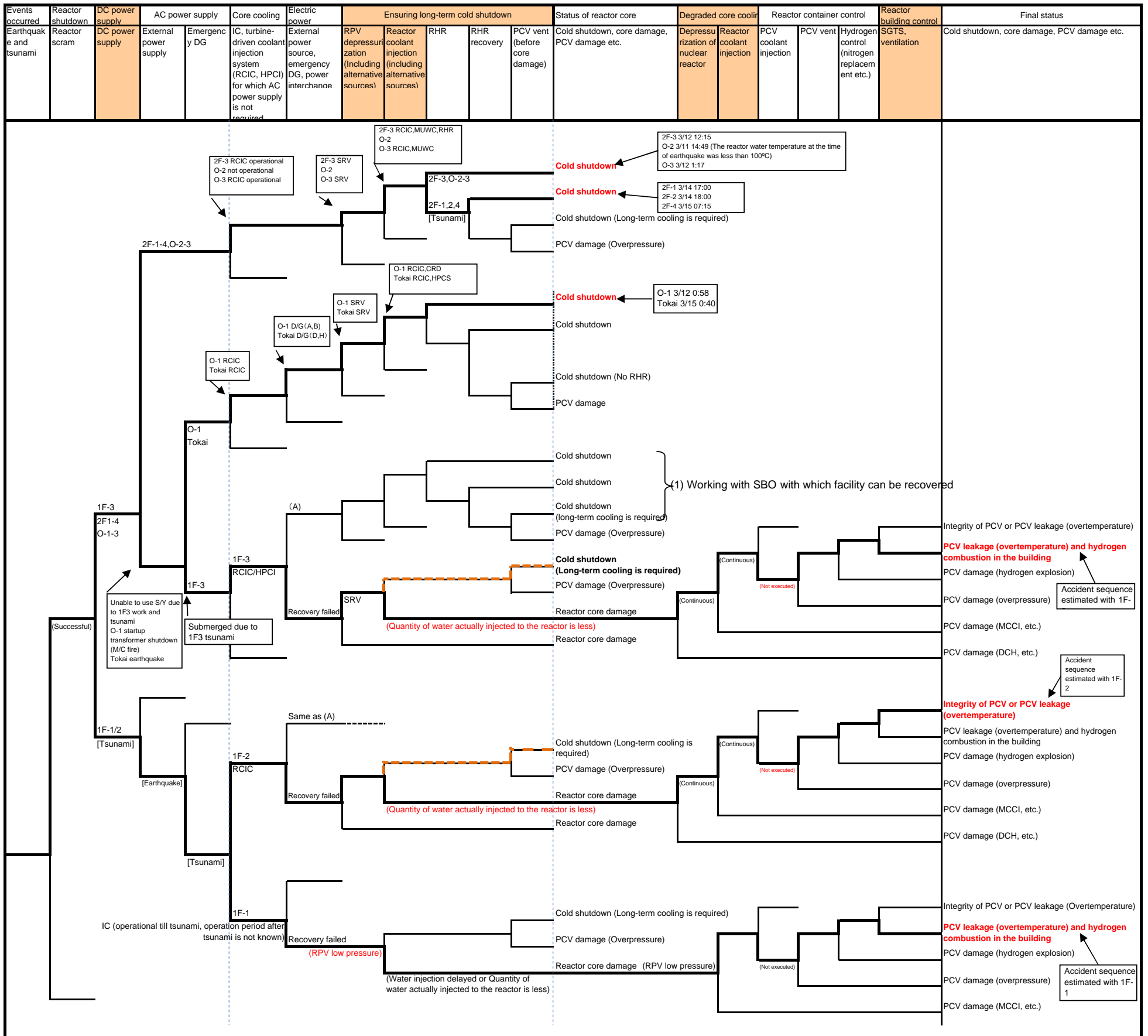

Figure 3.6-1 Disaster identification events tree in Fukushima Daiichi Nuclear Station Units 1 to 3, Fukushima Daini, Onagawa, Tokai Daini

Table 3.6-1 Comparison of conditions and specifications of plants that were damaged in the tsunami following The Great East Japan Earthquake

		Fukushima Daiichi						Fukushima Daini					
		1	2	3	4	5	6	1	2	3	4		
Condition of plant when earthquake occurred		Operational	Operational	Operational	Suspended	Suspended	Suspended	Operational	Operational	Operational	Operational		
Condition of the plant after tsunami	External power supply	Among 6 lines (1 line under construction), all unusable ^{*1}						Among 4 lines (1 line under construction), 1 line usable ^{*1}					
	Emergency DG (main body)	Existing DG (1A, 1B, 2A, 3A, 3B, 4A): Damaged Extension DG (2B, 4B): No damage				No damage		Damaged	No damage				
	Power panel (M/C, P/C, DG)	Emergency	Damaged (except part P/C)				No damage		Damaged (part M/C, P/C usable)	No damage (part P/C unusable)			
		Normal	Damaged (except part P/C)						No damage				
	Emergency cooling system seawater pump (main body)	Damaged						RHRS No damage [Loss of power]	No damage to RHR (B) only [Loss of power]	RHRS No damage	No damage to RHRS (D) only [Loss of power]		
	Emergency cooling system (Including Emergency condenser (IC))	IC (operational time unknown)	RCIC (Operational for approximately 3 days)	RCIC (Operational for approximately 1 day), HPCI (Operational for approximately half a day)	-			(Suspended)	RCIC	RCIC	RCIC	RCIC, HPCS	
	Severe accident countermeasure equipment	Containment vessel vent	○	?	○	-	-	-	(Vent line configuration complete)				
MUWC alternative injection		×	×	×	×	×→○	○	○	○	○	○		
Specifications of each plant	Expected height of tsunami (Society of Construction Engineers)	O.P.+5.7m						O.P.+5.2m					
	Height of tsunami at arrival	Approximately +13m ^{*2}						Approximately +9m ^{*2}					
	Site height	O.P.+10m			O.P.+13m			O.P.+12m					
	Principal building surrounding immersion depth [Inundation height]	Approximately 1.5 to 5.5m [O.P. approximately +11.5 to +15.5m ^{*3}]				Approximately 1.5m or less [O.P. approximately +13 to +14.5m]		Approximately 2.5m or less (almost zero except surroundings of Unit 1) [O.P. approximately +12 to +14.5m ^{*4}]					
	Deployment of power panel (M/C, P/C), emergency DG (building, hierarchy)	Emergency	DG	T/B B1F	T/B B1F Common pool 1F	T/B B1	T/B B1F Common pool 1F	T/B B1	C/S B1F D/G building 1F	C/S B2F	C/S B2F	C/S B2F	C/S B2F
			Power panel	T/B 1F C/B B1F	T/B B1F T/B 1F Common pool B1F	T/B B1F	T/B B1F T/B 1F Common pool B1F	T/B B1F	C/S B2F C/S B1F C/S 1F DG building B1F	C/S B1F Hx/B	C/S B1F Hx/B 1F	C/S B2F Hx/B	C/S B1F Hx/B
		Normal	Power panel	T/B 1F	T/B B1F T/B 1F 2SA building 1F	T/B B1F C/B B1F	T/B B1F T/B 1F	T/B B1F T/B 2F C/B B1F	T/B B1F	C/B B1F C/B 1F Hx/B	C/B B1F C/B 1F	C/B B2F C/B 1F Hx/B	C/B B2F C/B 1F
	Availability of Air-cooling DG (Y/N)	N	Y (DG2B)	N	Y (DG4B)	N	Y (DG6B)	N	N	N	N		
Diversity in external power supply (diversity in no. of lines, switchyard)	6 lines						4 lines						
Water-tightening (pump area, building)	Seawater system installed outside the building						Although the seawater system was installed in the building, electrical power systems were damaged (except B system of Unit 3)						

T/B: Turbine building, Common pool: Common pool building, C/B: Control building, C/S: Combination structure (Waste disposal building, Gaseous waste disposal building are combined and stored in 1 building around the conventional reactor building), Hx/B: Heat exchanger building

*1: Damage to transmission tower, switchyard and such like is damage due to the earthquake, *2: Height of tsunami in tide station installation position of both the power plants. For instrument damage, the actual height of tsunami in tide station is unknown, *3: O.P. approximately +16 to +17m [immersion depth approximately 6 to 7m] locally in the southwest of the said area, *4: O.P. approximately +15 to +16m [immersion depth approximately 3 – 4m] locally from the south of Unit 1 till the seismic isolation significant buildings

Table 3.6-1 Comparison of conditions and specifications of plants that were damaged in the tsunami following The Great East Japan Earthquake

		Onagawa			Tokai Daini		
		1	2	3			
Condition of plant when earthquake occurred		Operational	Start-up	Operational	Operational		
Condition of the plant after tsunami	External power supply	Among 5 lines, 1 line usable			Among 3 lines, all unusable ^{*1}		
	Emergency DG (main body)	No damage [*] * In Unit 2, as the RCW (B) system and HPCW system were flooded, DG (B) and DG (H) could not be used.			No damage		
	Power panel(M/C,P/C,DG)	Emergency	No damage			No damage	
		Normal	M/C 6-1A Fire	No damage		No damage	
	Emergency cooling system seawater pump (main body)	RHRS, ECWS No damage	RSW (B) system: Damaged RSW (A) system and HPSW system no damage	RSW, HPSW No damage	RHRS No damage [A system Loss of power] DGSW(2C) damaged		
	Emergency cooling system (Including Emergency condenser (IC))	RCIC, HPCI	RCIC, HPCS		RCIC, HPCS		
	Severe accident countermeasure equipment	Containment vessel vent	-	-	-	-	
MUWC alternative injection		-	-	○	-		
Specifications of each plant	Expected height of tsunami (Society of Construction Engineer)	O.P.+13.6m			Altitude + 4.9m		
	Height of tsunami at arrival	O.P.+13.0m			Altitude + 4.8-5.3m		
	Site height	OP+14.8m [*] * Crustal movements around the power station due to the earthquake has been estimated to be approximately -1m, currently it is 13.8m			T.P.+8.0m [*] * Value before earthquake		
	Main building surrounding immersion depth [Inundation height]	No immersion			No immersion		
	Deployment of power panel (M/C,P/C), emergency DG (building, hierarchy)	Emergency	DG	C/B B3F	R/B 1F	R/B 1F	C/S B1F
			Power panel	T/B B1F, C/B B2F	R/B B1F	R/B B1F	C/S B2F C/S B1F C/S 1F (direct current power supply panel)
		Normal	Power panel	T/B B1F	C/B B1F	S/B B2F	C/S B2F C/S B1F
	Availability of Air-cooling DG (Y/N)	N			N		
Diversity in external power supply (diversity in no. of lines, switchyard)	5 lines			3 lines			
Water-tightening (pump area, building)	Sea water system installed outside the building			Installed tsunami countermeasure side wall of pump area T.P.+6.1m Affected the under construction sealing work of the wall penetration of one side pump area			

T/B: Turbine building, Common pool: Common pool building, C/B: Control building, C/S: Combination structure (Waste disposal building, Gaseous waste disposal building are combined and stored in 1 building around the conventional reactor building), Hx/B: Heat exchanger building

*1: Damage to transmission tower, switchyard and such like is damage due to the earthquake

3.7 Causal analysis

An event tree analysis of the Fukushima Daiichi accident has shown that the major cause for aggravation of the situation was the loss of all safety systems due to the failure of power-supply sources, which were necessary to activate the safety systems.

According to the same analysis, other nuclear power stations averted a similar deteriorating situation largely due to the securing of power supplies.

Nuclear power stations are equipped with emergency DGs and designed to promptly replace external power supplies. At Fukushima, the emergency DGs were submerged. Furthermore, even if the external power supplies had been restored, emergency power-supply devices (such as emergency DGs and power-supply vehicles) could not have been connected because the power panels were also submerged as a result of the massive tsunami. This was a major reason why the situation was exacerbated.

In short, the real issue was the lack of preparing for such a state of emergency. Stricter safety measures could have given different results. A worst-case scenario and countermeasures for it should have been developed. For example, “if a tsunami reaches the station premises, water may come into the buildings and important safety equipment including power panels may be submerged. With this in mind, seal such important systems to prevent water from seeping in or encase them in a watertight compartment. Reinforce facilities and equipment in the event such protection is lost, and furthermore, be prepared to deal with such a situation in case such enhancement is not sufficient.”

The major cause for aggravation of Fukushima Daiichi situation was the loss of power-related facilities and equipment such as external power supplies, emergency DGs and power panels, as well as the lack of preparedness for dealing with the functional loss of those facilities caused by the tsunami.

While securing a power supply could have mitigated the emergency to a certain extent, cooling functions would also have needed to be secured for recovery of the safety systems. During the disaster, Fukushima also lost component cooling systems as a result of the lack of seawater pump functions. Therefore, stringent emergency measures are needed for power supplies as well as for cooling systems.

We have classified identified issues into the following five categories. Chapter 4 will describe these issues and required preparation and measures:

- Countermeasures against earthquakes and tsunamis (natural hazards)
- Securing of power supply
- Measures against loss of heat sink systems
- Measures against hydrogen leakage
- Preparation for emergencies

Category	Issues and requirements
Countermeasures against earthquakes and tsunamis	<ul style="list-style-type: none"> • Seismic adequacy of external power supplies • Tsunami countermeasures for switchyards • Tsunami countermeasures for seawater systems • Protection of seawater pump room from submergence • Tsunami countermeasures for emergency DGs • Air/water tightness of opening of the buildings
Securing of power supply	<ul style="list-style-type: none"> • Only one incoming panel to receive external power • Reliability of power supplies in case of tsunami • Submergence of power supply systems • Exhaustion of DC power supply • Securing of battery capacity • Obtaining power from external sources (e.g., power-supply vehicles) • Securing of AC power supply • Cable installation for alternate power sources
Measures against loss of heat sink systems	<ul style="list-style-type: none"> • Submergence of seawater pumps • Ensuring entire facilities and equipment so as it cannot be put out of commission by a single event • Setting up heat sink systems that will not be nullified by tsunamis • IC isolation signal in the event of the loss of DC power supply • Securing of materials and equipment to cope with valve drive failure • Establishing emergency procedures and training • Loss of freshwater sources • Earthquake protection and tsunami countermeasures for FP piping • Procurement of fuel for fire engines • Enhancement of drive source for pressure-retaining vent line valves • Inoperability of rupture disks at low pressure • Securing of compressed air to maintain opening container ventilation valve
Measures against hydrogen leakage	<ul style="list-style-type: none"> • Reinforcement of containment vessel gasket and penetration area sealing • Leakage from pressure-resistant ventilation line to buildings • Circulation between buildings that share the same exhaust stack • Hydrogen retention in R/Bs • Detection of hydrogen
Preparation for emergencies	<ul style="list-style-type: none"> • Securing sufficient personnel for radiation management and monitoring • Protection of radiation control facilities from tsunami damage • Obstructions created by earthquakes and tsunamis • Communication methods in the event of the loss of AC power

Category	Issues and requirements
	<ul style="list-style-type: none"> • Materials and equipment to support nighttime and indoor operations • Materials and equipment to secure road access • Securing of more than one access route within the premises • Support systems between power companies • Deterioration of environment due to hydrogen explosion and rising radiation

Source:

- (1) Report of Japanese Government to the IAEA Ministerial Conference on Nuclear Safety (June 2011)
- http://www.kantei.go.jp/jp/topics/2011/pdf/houkokusyo_full.pdf
 - http://www.kantei.go.jp/jp/topics/2011/pdf/app_full.pdf

Chapter 4 Lessons Learned and Measures to Take

As described in Chapter 3, the situation at the Fukushima Daiichi Nuclear Power Station became serious due to the loss of power supplies as a result of destruction of most safety equipment, except for few of them, by the tsunami, as well as the failure of backup measures (severe accident measures) that were expected to control the situation.

From this accident, we have learned that the following five preparations and countermeasures are critical:

- Countermeasures against natural hazards
- Securing of power supply
- Measures against loss of heat sink systems
- Measures against hydrogen leakage
- Preparation for emergencies (training and drills)

4.1 Countermeasures against natural hazards

This document describes the damage caused by the earthquake and subsequent tsunamis.

The size of the earthquake was mostly within the predicted values for the facility design. The post-evaluation conducted by TEPCO utilizing acquired seismic waves showed that the safety devices and equipment would not have been inoperable. However, the combination of several earthquakes within a close proximity created a massive tsunami. The possibility of this phenomenon had never been considered. The height of possible tsunamis needs to be re-evaluated based on this newly recognized phenomenon.

Power supplies for the station were damaged by the tsunami. Calculation based on outdated knowledge did not anticipate that the height of a tsunami would exceed ground level at the station. Therefore, the possible consequences of seawater infiltration were not carefully considered and sufficient countermeasures were not taken.

While the precise size of natural hazards such as tsunami and typhoons is not foreseeable, we must prepare for hazards that may exceed the calculated design basis. If there is a possibility of a severe power station accident, even though the probability of that possibility is minimal, we must take steps to protect existing properties and bring temporary facilities and equipment to bear in order to improve endurance and resolve vulnerability issues.

4.2 Preparation of Power Sources

In terms of power sources, power will be supplied by the external power system if the plant's generation stops. Should this be impossible, the emergency DG will start to deliver power to the safety system components. Basically, there are two trains with a 100% capacity for the emergency DG, and three trains depending on the reactor type. Power sources are designed considering redundancy and diversity.

In Fukushima Daiichi's accident, the supply of the external power supply stopped due to the earthquake and the tsunami entering the premises inundated the power panel and emergency DG, thus causing a station blackout. Some DC power

supplies were not inundated, but they were dead before the power was restored because their battery capacity was limited. As a result, it led to loss of function of each piece of equipment, causing the accident to become worse. On the other hand, one air-cooled emergency DG of Fukushima Daiichi's Unit 6 was not affected by the tsunami and maintained its function. Unit 6 was successfully led to a cold shutdown without causing an accident because it was off-line with relatively low decay heat and fairly much time. This is a good example which should be used as a countermeasure in future.

Because of the submerged DC power panel and dead batteries, the safety system components lost their functions and the instruments in the main control room also lost their functions. Failure to grasp the plant status due to loss of these functions is one of the factors which led to the accident. If the instruments in the main control room required for grasping the plant status lose their functions, it will be very difficult to attend to the accident thereafter. Therefore, it is important to take sufficient measures considering the effect of loss of DC power supply by taking measures to secure the power source for the instruments necessary for accident response among instruments in the main control room.

For power sources, it would be a good idea to be better prepared for hazards to the existing equipment and also to take measures in advance so as to ensure power supply by another means considering a case where such functions are lost.

For example, it is possible to take measures for protection against tsunami by making the installation sections watertight. To avoid loss of function of the existing equipment, it is also possible to take measures to supply power by deploying power-supply vehicles and deploying individual batteries.

4.3 Measures against loss of heat sink systems

As mentioned earlier, one of the major causes behind the aggravation of the Fukushima situation was the functional failure of emergency DGs due to the loss of the power supply. While some of the emergency DGs failed to function as a result of submergence/the submergence of the power panels, lack of cooling water due to damage to seawater pumps caused by the tsunami also contributed to the failure of some DGs.

Since the power failure caused severe damage, which was functional loss of various pieces of equipment, the seawater pump failure was not very conspicuous. However, loss of seawater pumps may lead to the simultaneous functional failure of various other pieces of equipment (such as cooling water destination pumps and heat exchangers), and result in further aggravation of the situation.

Therefore, seawater pumps must be protected from tsunami damage and measures to immediately restore their functionality are also important. A reactor cooling system must also be secured in case the seawater pumps become inoperable. In view of the need to cool reactors during power outages, alternate coolant injection by utilizing existing equipment or provisions for the establishment of temporary systems should be planned, and water sources should be secured to provide continuous cooling capability.

4.4 Measures against hydrogen leakage

Explosions allegedly of hydrogen at Fukushima Nuclear Power Station, Units 1, 3 and 4 destroyed the roofs and walls of these R/Bs and made it harder to deal with the situation.

Under such circumstances, the cooling down of the reactors and maintenance of the cooling effort must be the highest priority regardless of whether the core is damaged or not. Accurate data on the reactor core may not be available during a state of emergency at a nuclear power station and the possibility of core damage and hydrogen leakage must always be considered. Hydrogen is a substance that can easily escape. It is necessary to keep it in mind that the hydrogen leak may spread beyond the normal containment area.

A PCV is usually used to contain hydrogen. PCVs also act as recombiners in which nitrogen is added in order to inactivate the hydrogen.

However, in situations where the high temperatures and pressures exceed the design parameters, hydrogen may leak from penetrations or the flange gasket sealing of PCV and then accumulate inside of R/Bs. As the containment vessel ventilates, hydrogen then may enter the pipes connected with exhaust stacks. This possibility should also be kept in mind.

Under the presumption that hydrogen is susceptible to leakage, countermeasures should be established to stop the accumulation, leakage and wraparound, and provisions for controlled burns should be developed. Power outages also need to be assumed whenever these measures are taken.

4.5 Preparation for emergencies (training and drills)

The employees and contractors at Fukushima Daiichi had to work under extreme circumstances: a power blackout, loss of meters and gauges, loss of communication ability, high radiation, a highly contaminated environment, scattered rubble and debris, ongoing tsunami warnings, multiple reactor unit accidents, as well as having to deal with other emergency operations that included the need to arrange for temporary hoses and cables, and radiation monitoring equipment. Few of those workers had ever had such experience and that was one of the reasons why it took an inordinate amount of time to carry out these emergency tasks. On-site personnel were not the only ones who faced difficulties. TEPCO Headquarters' command structure was also plunged into turmoil due to the number of accidents and the rapidly spreading damage.

We must establish provisions for dealing with such situations with restricted conditions.

The seismic isolated building effectively functioned as an emergency command post. This fact is an excellent case example for other power stations. Based on the experience gained from this accident, various facilities and equipment have been added and new emergency manuals have been established. Training and drills for possible stringent conditions must be conducted by using currently available facilities and equipment and manuals in order to be proficient in responding to an emergency. Crisis handling systems, line of command and efficacy of each measure must be evaluated and improved upon, if necessary, during such training.

Examples of emergency measures are as follows:

4.6 Countermeasures against earthquakes and tsunamis (example measures)

4.6.1 Assumption of earthquake and tsunami strength

Although the strength of the earthquake on March 11, 2011 exceeded the maximum response acceleration value against basic design earthquake ground motion, Ss, all the emergency functions, “stop,” “cool” and “confine” at Fukushima Daiichi were functioning during and right after the quake. Also it was assumed that the function of safety component was secured until the tsunami descended upon the site.

Seawater pumps and emergency DGs became inoperable once the massive tsunami reached the grounds of the station site and after the quake had disrupted the external power supply. Furthermore, all power sources and ultimate heat sinks were lost simultaneously as a result of submergence of the metal clad switchgear, power center and D.C. power supply systems.

Road damage and debris caused by the quake and tsunami interfered with operations to connect external power supplies. As a result, the Station Blackout lasted for hours and coolant injection into reactors took a long time.

Findings and lessons learned

- The combination of multiple hypocenters created a massive earthquake (in magnitude, size of affected area and length of shift of a geological fault). Such interrelated earthquakes had not been anticipated.
- Despite the strength of the quake, the earthquake response spectrum located on the foundation of the R/Bs showed about the same value as the response spectrum for the basic design earthquake ground motion, Ss. Essential safety facilities and equipment continued functioning.
- Large shift of a geological fault triggered huge tsunami as big as the earthquake. The combination of such waves created a massive tsunami that exceeded the predicted tsunami water level and descended upon the station, causing extensive damage.

Measures to take

Given the above findings, the following measures should be taken:

- The current basic design earthquake ground motion, Ss probably correspond to future earthquakes. However, possible combination of multiple hypocenters in the neighboring waters should also be considered in order to ensure safety.
- To calculate height of future tsunami waves triggered by earthquake, possible combination of multiple hypocenters should be considered as a wave source at the boundary of ocean-trench plates. The value of distance of possible geological shift at a hypocenter should also be set to larger value as appropriate.

Measures to deal with obstacles that interfere with emergency operations such as the handling debris are described in “4.5.4 Preparation for emergencies (heavy equipment and rescue efforts), and emergency cooperative system.”

4.6.2 Protection of the site from tsunami

The massive tsunami easily exceeded the elevation of the Fukushima Daiichi site. The reactor cooling system ceased functioning as a result of damage to the seawater systems and the loss of the power supply including emergency power. Tanks that were flushed away by the wave blocked roads, causing further delay in the preparing of injecting coolant by fire engines.

Findings and lessons learned

- Station equipment and facilities may submerge depending on their location and tsunami may cause seawater to prevent safety equipment from properly functioning.
- Debris and wreckage brought by tsunami may block emergency traffic from reaching the scene.

Measures to take

Given the above findings, the following measures should be taken:

- Safety requires that all power-supply facilities be located in an area that will not be affected by tsunamis. Coastal levees (tide barriers) or breakwaters must be installed. Alternatively, protection barriers or multilayered water protection measures need to be taken to ensure the safety of the facilities.
- Barriers, such as protection walls, that prevent structures from becoming floating wreckage and blocking access of emergency vehicles needs to be installed. Heavy equipment needs to be available in order to remove debris and wreckage.

4.6.3 Protection of buildings

Buildings were flooded by seawater from the tsunami, causing safety equipment to become inoperable.

(1) Water tightening of critical facility areas

Almost the entire area around the main buildings of Fukushima Daiichi were flooded by the tsunami. The water entered the buildings allegedly from ground-level openings such as doorways and equipment hatches, vent openings (louvered doors) and openings connected to under-ground trench ducts (cable and pipe pass-through slots).

Most emergency power panels in Units 1 through 5 and DC main busbar panels in Units 1, 2 and 4 were submerged. (There was no inundation in Unit 6.)

Emergency DGs also became inoperable in Units 1 through 5 due to the submergence of the DGs themselves or their power panels. Air-cooled emergency DGs were installed in Units 2, 4 and 6, and the ones in Units 2 and 4 became inoperable due to submergence of power panels. (The water-cooled emergency DG in Unit 6 also became inoperable due to the inoperability of the seawater cooling system stemming from damage as a result of the tsunami.)

The framework of main building including outside walls and columns did not suffer significant damage from tsunami. However, inundation into the buildings from openings caused the loss of power-supply equipment resulting in loss of all DC/AC power supplies and ultimate heat sinks.

Findings and lessons learned

- Insufficient preparation to prevent inundation and inadequate endurance to wave power allowed seawater to enter the main buildings from broken doors on the sea side and from other openings such as louvered doors.
- As a result of the tsunami, seawater overflowed into important facilities and equipment (such as electrical facilities) from entrance doors and other openings including pipe penetration and resulted in those facilities and equipment becoming inoperable.
- Recovery operations were delayed due to accumulated seawater inside the buildings.

Measures to take

Given the above findings, the following measures should be taken:

- Steps to better protect against inundation, including improving sealing capability at penetration and openings (such as doors and vents) depending on the inundation height, must be taken for an unanticipated size of tsunami.
- Impact of inundation must be minimized by the water tightening of doors to key safety facilities for an unanticipated size of tsunami.
- Portable drain pumps need to be equipped in buildings in order to be able to drain seawater and ensure speedy restoration.
- Doors facing the ocean and that may receive direct impact from a tsunami must be reinforced.

(2) Protection of seawater systems against inundation

At Fukushima Daiichi, seawater systems ceased functioning due to the unanticipated size of the tsunami, but the system at Units 5 and 6 was reestablished by using substitute pumps. At Fukushima Daini, all seawater systems except the one at Unit 3 ceased functioning, but the system was eventually brought back on line by using replacement motors. At Tokai Daini Power Station, all seawater pumps remained operational except one because a floodwall was under construction around the seawater pump area. No stations experienced any blockage or damage of intake channels due to debris and wreckage.

Findings and lessons learned

- Fukushima Daiichi lost all seawater pumps due to the unanticipated size of the tsunami.
- Specific measures must be taken so as not to lose the operation of all of seawater pumps at the same time due to tsunami.

Measures to take

Given the above findings, the following measures should be taken:

- Protection against inundation including the building of floodwalls around seawater pumps must be initiated.
- Extra motors must be reserved to ensure a speedy recovery.
- Portable seawater pumps should be held in reserve or waterproof pumps should be installed.

4.7 Preparation for power supply (example measures)

4.7.1 SBO and loss of DC power supplies

Transmission of the external power supply broke down and external power was lost due as a result of the earthquake. The emergency DGs started up right away as intended and the required power supply for the station was reestablished.

However, due to the inordinate size of the tsunami, power-supply facilities, including emergency DGs that were not capable of withstanding inundation, were subsequently submerged and all AC power supplies were lost. Power from D.C. power supply system that were not submerged ceased later due to the exceeding of battery life. As a result, Fukushima Daiichi lost all power supplies.

Traces of the tsunami showed that it reached the area around the switchyard and incoming electricity transformers. The power supply line from neighboring station, which is one of the severe accident response measures, failed because the closest station also went down.

Fukushima Daini, Units 1, 2 and 4, also lost their seawater cooling systems. However, core cooling was maintained by RCIC followed by an alternate cooling operation. Meanwhile, the seawater system was reestablished and the radiation cores went into a cold shutdown state. Thus, the safety of power station can be ensured through the use of emergency equipment and facilities provided the power supply is secured.

In order to recover all the power supplies, Fukushima Daiichi tried to bring power supply vehicles cars and connect them to the station facilities. Access to the station was hindered due to congestion of the surrounding roads and road damage as a result of the earthquake. Although batteries and manpower to lay heavy cables was brought to Fukushima to assist with the speedy recovery effort, submergence of power panels resulted in an extended power blackout period.

Findings and lessons learned

- Emergency DGs were installed to cover the loss of external power supplies. However, emergency DGs also became inoperable due to the tsunami. Further backup systems are needed.
- In order to ensure the reliability of incoming electricity transformers and switchyards, the external power supply for them needs to be protected from tsunamis.
- Emergency DGs and related facilities were submerged and became inoperable as a result of the tsunami. These DGs need to be protected against such damage.
- Some of D.C. power supply system were submerged and lost functionality. Other D.C. power supply system that were not affected by the tsunami ran out of power and became inoperable because they could not recharge. Such long-term needs to be considered.
- Severe accident response facilities (power panels to bring electricity from other stations) were submerged by the tsunami and was unusable. These facilities need to be protected from inundation.
- As an emergency response to the loss of all the power supplies, power supply vehicles were sent to Fukushima Daiichi, but were delayed because of the adverse conditions brought on by the earthquake and tsunami. The

mobility of power supply vehicles is very useful but the way to provide speedy access under adverse circumstance must also be developed.

Measures to take

Given the above findings, the following measures should be taken:

- Backup power supply in the event emergency DGs become inoperable
 - Reserve earthquake and tsunami-proof power supply vehicles or large-capacity batteries (gas turbines or diesel generators) as backup power supplies and the establishment of emergency procedures (e.g., steps to obtain fuel such as light oil and how to connect power supplies).
- Protection of external power supplies against inundation
 - Review location and arrangement of incoming electricity transformers and switchyards, and make them watertight or protect against possible water damage as needed.
- Protection of emergency DGs and related facilities against tsunamis
 - Review location and arrangement of emergency DGs, power-supply facilities (high and low voltage) and cooling systems for emergency DGs, and make them watertight or protect against possible water damage as needed.
- Protection of D.C. power supply systems against inundation
 - Review location and arrangement of D.C. power supply systems, and make them watertight or protect against possible water damage as needed.
 - Establish DC power supply (battery) charging routes from backup power supplies.
- Protection of inter-building power-supply facilities (severe accident measures) against inundation
 - Review protection of inter-building power-supply facilities (severe accident measures) against inundation, and improve reliability as needed.

In order to improve the seismic capacity of external power supplies, all power companies have been directed by the government to review the seismic adequacy of their transmission wires and improve the reliability of the facilities at locations where landslides may occur. Power companies are also to address the reliability and performance of multiple power systems.

Expansion of battery capacity, which is one of the challenges addressed, is a logical strategy, but feasibility is questionable due to required space for such a system and its limited effectiveness. Therefore, in order to secure DC power supply, the first step will be to secure power supplies to feed the DC power supply. The second step will be to establish methods to charge batteries as soon as the power supply has been lost.

Factors that could interfere with power recovery operations are common to other operations. These factors and approaches are described in “4.10 Preparation for emergency situation.”

4.8 Examples of measures addressing heat sink loss

4.8.1 Water injection in reactors

In this accident, the electric-driven water injection system of ECCS could not be activated due to the loss of power supply while the steam-driven water injection system could not continue to operate due to the loss of the control DC power supply batteries after a certain period of time or for some unknown reason.

In this case, the alternative low-pressure cooling water injection system required some time before starting cooling water injection because it needed to first depressurize the reactors which lost the driving power supply and the driving air pressure of SRV (ADS function, relief valve function). In addition, MUMC, one of the alternative water injection systems, could not operate because the pump was inundated and the FP diesel fire pump failed. Furthermore, the alternative high-pressure injection facilities (CRD, SLC) were in a state that could not be started due to the complete loss of power supply.

As stated above, the water (fresh water) injection to reactors could not be implemented using the existing injection facilities, and eventually fire engines were used for emergency injection of seawater.

In addition, as for water injection facilities, the actual situation of damage was unknown because they could not function due to the loss of power supply, except some of the equipment was known to be damaged by seawater flooded into the building.

Findings and lessons learned

- The Station was unsuccessful in dealing with the situation because all ECCSs stopped working due to complete loss of power supply for a long time caused by the earthquake and tsunami, and because the facilities for preventing severe accidents could not be used. Therefore, it is necessary to examine the measures to ensure long-term water injection (including securing water sources) even if tsunami and earthquake hit.
- In the event that the high-pressure injection system loses its function, the alternative low-pressure injection should be performed to depressurize the reactor. However, it is difficult to reduce the pressure due to the loss of the supply which drives the valve for reactor depressurization. It would take some time before the alternative low-pressure injection system can be used. Therefore, it is necessary to examine the measures to cope with loss of driving source of facilities required for reactor depressurization.
- For the body of the water injection facility, it is also necessary to have measures to deal with seawater flood into the building in a tsunami.

Measures to take

In light of those described above, the following measures should be considered to cope with, for example, the events of BWR.

- To ensure the water injection function to achieve secure water injection to reactors in the event of the loss of existing driving supplies for a long period of time.
 - To improve the power supply reliability for the existing injection system by deploying a backup power supply vehicles or large-capacity power supply
 - To secure alternative means of injection to reactors using portable power

- pumps and hoses that do not depend on the existing power supply
 - To prepare backup power supply and reserved air cylinders necessary for driving to ensure reliable depressurization of reactors through SRV
 - To secure water source (including seawater as the last resort)
- Among the severe accident prevention facilities, there should be anti-inundation measures by establishing the seawall and watertight doors to the extent expected as the last resort in combination with other alternative means.
- To establish anti-inundation measures by ensuring the watertightness of compartments of safety equipment, such as emergency cooling systems for reactor cores.

In PWR, there should be cooling means of the secondary system required when a station blackout occurs. In these means, water will be supplied to the steam generators through the turbine-driven auxiliary water feed pumps with steam as the driving source; and a steam generator is available for discharging the steam through the main steam relief valve. This is equivalent to secure the function of water injection to reactors in the BWR; therefore, it is important to ensure the means of water supply to steam generator and steam discharge means. In order to achieve continuous heat removal for a long time, the following measures are suggested.

- Improve the power supply reliability for the existing water injection system by deploying a backup power supply vehicle or large-capacity power supply.
- Secure alternative means of water injection to steam generators using portable power pumps and hoses that do not depend on the existing power supply.
- Secure more reliable measures to cool the reactors with the steam generators through the main steam relief valve (including reserved air cylinders).
- Secure water source (including seawater as the last resort).

As stated in the report, “the fire hydrant erupted water, but the filtered water could not be used as the water source.” At this investigation meeting, there was an argument whether it is necessary to improve the reliability of fire-fighting water system. However, Tokyo Electric Power Co., Inc. explained that a fact that “damage to the FP by the earthquake caused difficulty in responding to the accident” was not yet certain. Therefore, the need to examine FP will be decided after the investigation results of Tokyo Electric Power Co., Inc. become available.

4.8.2 Loss of seawater cooling

As the tsunami was stronger than expected in the Station’s design, the seawater pump motor and ancillary equipment were damaged and could not operate. The heat removal route of “reactor → residual heat removal system → reactor building closed cooling water system → reactor building closed cooling seawater system → seawater” for final heat relief (final heat sink) lost its function, so the heat generated by reactor could not be removed.

In addition, due to the effects other than loss of function of the seawater pump, the ancillary equipment cooling water pump and heat exchanger required for

cooling by seawater pumps could not be used; therefore, ECCS and ancillary reactor equipment could not operate even without the power loss.

Findings and lessons learned

- It is necessary to examine the measures for inundation caused by tsunami because the seawater pumps will no longer be used in an unanticipated tsunami. (Refer to the section of Tsunami for measures)
- It is necessary to examine the means to recover inundated seawater pumps.
- It is necessary to examine a way to secure the heat removal route in the event that the seawater pumps could not be recovered early.

Measures to take

In light of those described above, the following measures are suggested.

- Alternatives to seawater pumps
 - Deploy redundant seawater pump motors and develop a replacement procedure after loss of functionality
 - Ensure the power supply which can back up the minimum functions required for seawater pumps
- Have measures for early recovery of seawater pumps
 - Have the cleaning and drying materials available for seawater pump motors
- Ensure an alternative heat removal route
 - Disperse the heat to atmosphere through the containment vent (see the following section)

In addition to the need to take the same measures as above for PWR, there should be an alternative heat removal route “reactor → steam generator → atmosphere” using the secondary system with steam generator in the event that the heat removal route “reactor → residual heat removal system → reactor building closed cooling water system → reactor building closed cooling seawater system → seawater” as final heat sink loses its function.

4.8.3 Containment vent

In this accident, the route for heat removal to the final heat sink (sea) failed to function due to the loss of seawater cooling; therefore, the heat from reactor was handled according to the procedure using the route “reactor → containment → atmosphere (vent).”

To allow a rapid depressurization by opening the SRV, it was necessary to lower the containment pressure through the vent before discharge of steam.

Furthermore, when the containment pressure rose, the venting and depressurization were performed in order to ensure the integrity of containment.

In this case, it needed some time before starting the vent because of the following reasons.

- The containment pressure could not be properly understood because of the loss of power supply to the metering instruments.
- The remote control was disabled due to the loss of power supply to the vent valve and the cylinder pressure. Although alternative manual operation was

planned, some time was needed to examine and establish the ways for implementation.

- In addition, due to the increase in building radioactive dose and torus room temperature, it was extremely difficult to access the vent valve area.
- The evacuation of the surrounding residents was finally confirmed.

Findings and lessons learned

- The temporary rechargeable batteries that could be used for metering instruments, and temporary power supply and air cylinder for driving the vent valves were not prepared in advance for the event when the station blackout continued for a long period of time; the radioactive dose was very high around the vent valve area when the reactor core was damaged, and some time was needed for the vent operation. Therefore, it is necessary to examine how to improve the reliability of vent operation in the event a station blackout continues for a long time.
- It is necessary to remove the radioactive materials other than rare gas caused by the scrubbing effects of pool water of S/C while strengthening the prevention measures for over-heating damage in order to prevent damage to containment while performing the vent.

Measures to take

In light of those described above, the following measures are suggested in case of BWR.

- Improve the reliability of vent operation during a complete loss of power supply
 - Deploy temporary power supply to feed the monitoring instruments required to determine the vent preparation and vent implementation
 - Deploy a backup power supply and driving source for vent operation
- Optimize the operating conditions of the vent
 - Conduct future examinations for optimization of the time to start the vent and perform a review as needed.
- Reinforce the alternative containment spray after damage to the reactor core

In addition, in the PWR, there should be a secondary cooling system with steam generator even if the heat removal to the final heat sink fails due to the loss of seawater cooling. This system should be able to continue to remove the heat generated by the reactor. Therefore, for PWR, it is not necessary to discharge the energy in the containment through the vent.

The design of rupture disk has been established, and will include a function to prevent discharge into environment of the containment atmosphere caused by malfunction of valves, and the operation pressure will be set higher than the designed pressure in consideration of the malfunction. If the valve of the vent system can be reliably opened during the pressure rise within the containment, it will achieve its original function of lowering the pressure; therefore, it is believed not necessary to make a change in the design of the rupture disk. However, the measures to lower the set value for operation of rupture disk, or to remove the rupture disk, will have a wider choice in response to accidents as these measures might depressurize the containment early; and whether these measures should be adopted will be determined based on judgment of electric

power, considering that there would normally be a small amount of emission of radioactive materials associated with malfunctions.

4.9 Hydrogen measures

In this accident, the hydrogen leaked and was deposited in the reactor building caused by the damage to the reactor core. As a result, the hydrogen-induced explosions occurred respectively in the Unit 1 reactor building at 15:36 on March 12, and in the Unit 3 reactor building at 11:01 on March 14.

Due to these explosions, it was difficult to lay power cables and connect the hoses.

Also, an explosion, possibly caused by hydrogen, occurred in the Unit 4 reactor building at around 6:00 on March 15.

Findings and lessons learned

- As a result of the hydrogen generated due to damage to the reactor core leaking into the reactor building and continuing to collect in one place, a hydrogen explosion occurred in the reactor building. It is necessary to review measures to prevent such a situation.
- It is necessary to study measures to prevent the wraparound of hydrogen from the SGTS exhaust pipe, leaking of hydrogen into the ventilation system from the isolation valve between the vent line and ventilation system, and the wraparound of hydrogen via the junction of the ventilation stack from other units sharing the ventilation stack, at the time of containment venting using the pressure-resistance enhancing vent line.
- If the temperature in the containment vessel rises and the pressure also exceeds the design condition, hydrogen may leak from penetrations and gaskets in the containment vessel into the reactor building, leading to hydrogen explosion.

Measures to take

In light of those described above, the following measures are suggested.

- In order to prevent the hydrogen-induced explosion, it is necessary to examine measures to release or reduce emission of hydrogen which will be deposited in the reactor building.
- In this accident, it is necessary to examine the route of hydrogen leaked into the reactor building, and to examine the need to set hydrogen gas detectors to appropriately monitor the deposit of hydrogen in the reactor building if needed.
- If branch pipes are installed in the containment vent line, it is necessary to examine the measures to prevent the wraparound of hydrogen from such exhaust pipes.
- If an exhaust pipe is shared, it is necessary to examine the measures to prevent the wraparound of hydrogen to other units, and ensure independence in terms of engineering.
- It is necessary to have trainings and procedures designed to cope with leaks and deposit of hydrogen.

As for the containment penetration and seals, it is unrealistic to demand proper sealing under a condition exceeding the designed, and measures should be proposed to avoid such a condition. Considering that hydrogen is easy to leak if

the reactor core is damaged, it is necessary to take corresponding measures to cope with the hydrogen leaks that may occur.

4.10 Emergency preparedness (especially training)

4.10.1 Training

Because of the severe work environment of the incident response site in this accident where there was hardly any lighting or communication methods, and high-dose of radiation with scattered wreckage of building, it was very difficult to perform fieldwork such as cable laying from power supply vehicles and join up, laying alternative injection hose and so forth. Usually the fieldwork needs to take a lot of time and trouble, but we tackled it within a relatively short time thanks to the workers' efforts. The fact that fieldwork would require this time had not been assumed in the countermeasures training for severe incidents so far.

As this accident is a multi-unit and coincident accident that is not presumed in the conventional training, prompt decision-making and response were required with a limited number of workers on a moment-to-moment basis.

Findings and lessons learned

- The countermeasures training for severe incidents should include field operation training considering the fieldwork under the severe conditions based on real actions, and train on a routine basis so as to take systematical actions in the event of an accident.
- Workers should get training for various situations on a routine basis in order to take actions in line with time in the event, and are encouraged to understand how his or her incident response activities can affect the course of events.

Measures to take

In light of those described above, the following measures are suggested.

- Assemble knowledge and proficiency
 - Assemble the knowledge and proficiency requested for each personnel during a severe accident, and provide each personnel with a data-type education and proficiency training in an appropriate manner.
- Field trainings based on real actions
 - Provide workers with the field trainings for the fieldwork presumably required as countermeasures for severe incidents so as to take the workers' proficiency in procedures and methods to a higher level.
 - Simulate the fieldwork during nighttime or without communication methods, and the fieldwork with full range of protective gear such as protective clothing and full-face mask. Also consider an impact of obstacles on approaching the field.
- Training based on proceeding with time in the event
 - Provide a training having effectiveness with a focus on reliable cooperation and decision under the same condition as real such as blind training and real-time training in addition to training based on a scenario.
 - Confirm time required for such as approaching the field, wearing the protective gear, and performing fieldwork, and then ensure how his or her activities can affect the course of events.

- Make use of simulator etc. to enable each personnel to take actions in line with time in the event.

The training mentioned above is preferably provided on a regular basis to remind the lessons learned and to maintain or improve the proficiency continuously.

4.10.2 Air conditioning and shield at Main Control Room

In this accident, workers could not enter MCR or stay at MCR for a long time because of the high radiation dose.

And MCR ventilation system having a charcoal air filter for iodine removal did not work due to the loss of electric power for a long time; therefore it is necessary to wear a full-face mask even in MCR.

These conditions made MCR habitability lower, and this hindered incident response activities.

Findings and lessons learned

- Loss of electric power for a long time disabled the MCR ventilation system. In response to this situation, we need to consider a countermeasure.
- Due to the high radiation dose, workers could not enter MCR or stay at MCR for a long time. In response to this situation, we need to consider a countermeasure.

Measures to take

In light of those described above, the following measures are suggested.

- A countermeasure to ensure MCR habitability for a long time
 - Ensure power supply to facilitate the MCR ventilation system during emergencies. And therefore put the operation procedure for it in place.
 - Examine the reason why high radiation dose is increased so as to strengthen countermeasures of the radiation protection at MCR.

4.10.3 Measurement during accidents

In this accident, instrument power supply was lost, because D.C. power supply system had stopped working in addition to the fact that there was a station blackout for a long time. Therefore, important parameters such as reactor water level, pressure, and temperature were not measured, records for these parameters were lost, and the status of a reactor like the injection status was not determined. To restore the instruments, workers needed to connect batteries collected from vehicles to the MCR instrument board as temporary power supply.

And from the viewpoint of instrument data reliability, the indicated value of the reactor vessel level instrumentation system varied from instrument to instrument. According to comparative result of a water level instrumentation installed temporarily to confirm the reliability of instrumentations, the actual water level of reactor might be less than the measurement limit of the water level instrumentation in the fuel zone. Therefore, trend monitoring for reference-plane water level of the water level instrumentation indicated that the reference-plane water level might be lowered continuously by evaporation due to the effect of high temperature in the containment vessel.

As the accident progressed, workers were asked to make unexpected measurements such as water level measurements due to evaporation of pool water at the spent fuel pool, hydrogen-concentration measurement to determine hydrogen leakage and accumulation from the containment vessel at the reactor building. In fact, there was no means of measurement, so it became difficult to respond to the incident. Moreover, inside the building was exposed to high radiation and this prevented the workers from approaching the instruments so that restoring the measurement system became difficult.

Findings and lessons learned

- (Dependable supply of power) Losing MCR monitoring function due to the loss of electric power for a long time was beyond the scope of assumption. In response to this situation, some measures must be considered.
- (Enlargement of measurement specification) Because the reactor water level was less than the measurement limit of the instrumentation during a severe accident, we need to consider the outbreak of a severe accident in terms of the measurement system of important parameters that are necessary to understand the plant status.
- (Addition to measurement parameters) There was no means of handling unexpected measurement requests, which was not expected in conventionally assumed events such as hydrogen-concentration in the reactor building. In response to this situation, some measures must be considered.
- (Ensuring measurement reliability) There was no means of confirming the reliability of the measurement system (measurement data) regarding the important parameters such as reactor water level during a severe accident. In response to this situation, some measures must be considered.

Measures to take

In light of those described above, the following measures are suggested.

- (Considering dependable supply of power) Consideration for restoring instrumentation early in case of the loss of electric power for a long time.
 - Prepare temporary storage battery and connection cable near MCR as a backup of power supply.
 - Reconsider the instrumentation power supply such as utilizing power-saving technology or uninterruptible power supply if necessary.
- (Considering enlargement of measurement specifications) Consideration of the means to measure important parameters such as reactor water level to understand the plant status during a severe accident.
 - Consider how to measure important parameters during a severe accident in order to understand the plant status such as water level of the reactor.
 - Consider development of the measurement system having an enlarged measurement limit of reactor water level, and means to understand the reactor status by measuring the containment vessel even when reactor instrumentation is lost in view of the outbreak of a severe accident.
- (Considering addition to measurement parameters) Consideration of selecting parameters that are newly requested to measure in this accident, and measurement system for them. This is not requested in the conventionally assumed accident.
 - Establish a parameter measurement system such as

hydrogen-concentration in the reactor building.

- (Considering securement of measurement reliability) Consideration of a way to ensure reliability of the measurement system (measurement data) regarding the important parameters during a severe accident.
 - Develop a measurement system that strengthens environment resistance and a variety of measurement means in view of the outbreak of a severe accident.

4.10.4 Emergency operation facility

Emergency Operation Facility is a facility to give countermeasure instructions during an accident and placed within Examination Guide for Safety Design for Nuclear Power Facilities. However, in this accident the available communication methods between Emergency Operation Facility and MCR were only hotline and land line after station blackout. The communication environment became worse so that the communication between Emergency Operation Facility and the field was hardly established, which hindered discussions on countermeasures and posed a problem for giving instructions. And personnel went to the administration building, which was restricted area, to get valve drawings while there were aftershocks so as to study the procedure of vent operation for the containment vessel after the station blackout. The storage place of valve drawings should be reconsidered when discussing stored judgment material in Emergency Operation Facility.

From the viewpoint of radiation control in Emergency Operation Facility, since originally any buffering area was not specified to put on and take off radiation protective clothing in the earthquake-proof principal building where Emergency Operation Facility was located, the concentration of radioactive materials in the air of building was beyond the limits by law to the day of April 3, so that it did not protect workers from the risk of internal dose even in the building and it did not provide enough space for relaxation for workers who have been working over a long time.

However, the earthquake-proof principal building could withstand the earthquake and tsunami with independent emergency electric power supply unit and air conditioning system. Though it had problems as mentioned above, it is noticeable that it functioned as a base for incident response activities.

Findings and lessons learned

- Emergency Operation Facility is a facility to give countermeasure instructions during accident. It inevitably ensures the communication methods to MCR or the field and enables people to get plant parameters required for determining countermeasures even under the severe conditions such as station blackout. Also judgment materials for emergency countermeasures should be prepared at Emergency Operation Facility and personnel should be capable to get them easily if required.
- Emergency Operation Facility is a facility where workers stay and use when an emergency arises including radioactive release. It needs adequate radiation protection including preventing the internal retention of radioactive materials and considering the external environment when used.

Measures to take

In light of those described above, the following measures are suggested.

- Emergency Operation Facility is expected to use under the severe natural phenomenon such as an earthquake, tsunami, and under the severe conditions such as station blackout for a long time, releasing large amount of radioactive materials into the environment so that it should be prepared to provide its functionality considering above mentioned situations. Especially consider the following points.
 - Building designed and located to withstand an earthquake and tsunami
 - Station capable of using in case of the loss of external power supply for a long time and ensuring independent emergency electric power supply
 - Collecting the plant parameters required for the countermeasure instructions and ensuring the communication methods to MCR and the field
 - Radiation protection countermeasures considering large volume of radioactive material release
 - Ensuring habitability for long-stay workers
 - Ensuring emergency material for severe environment
 - Scrutinizing and ensuring judgment material required for emergency countermeasures

4.10.5 Radiation control and working control

In this accident, APDs which were used for personal exposure control, submerged in water and part of them became unusable, due to the effects of tsunami. Therefore, there were not enough APDs for all workers. Only some workers could use APD. And the exposure control system did not work due to the loss of power, so we had to manually record the irradiated dose. Charcoal filter masks which used as iodine adsorbent were also in short supply; as a result, the risk of internal exposure increased. Holding-counter type WBC for measuring internal exposure became unavailable partly because the background radioactive materials on site increased. Workers took measurements using mobile type WBC and measurements in other power stations, but it was not enough. It caused confusion because of the shortage of all sorts of radiation measuring instruments and radiation protective clothing, and also loss of related functions.

In the middle of the confusion, some people were exposed to radiation beyond the dose limit. We confirmed that multiple workers involved in emergency work were exposed beyond the dose limit of 250 mSv. And two female workers who stayed in the earthquake-proof principal building were also exposed beyond the dose limit of 5 mSv in 3 months as the total of external exposure and internal exposure. And 3 workers from the contracted company were exposed beyond 170 mSv, ignoring the alarm from the APD. Especially two of them, wearing low shoes, got their feet wet in radiated water. Since we suspected possible beta ray burns because there were radioactive materials on their shoes, they were taken to a hospital and then to the National Institute of Radiological Sciences (NIRS).

In the earthquake-proof principal building, since no buffering area was specified to put on or take off radiation protective clothing, the concentration of radioactive materials in the air of the building was beyond the legal limits by April 3.

In this accident, because of the vent operation for the containment vessel, radioactive material was released to the environment due to the hydrogen explosion, and scattered wreckage with a high dose of radiation, radiation

control service including measurement of the environment increased abruptly. Thus, it was very difficult to control the radiation.

Findings and lessons learned

- Due to the tsunami and loss of electric power for a long time, it was beyond the scope of assumption that personal dosimeters like APD would become in very short supply, that radiation protective clothing like masks would run short due to the rapid progress of the accident, and that WBC would become unavailable due to the high radiation dose.
- Because radioactive material possibly is released to the environment in activities such as the vent operation for the containment vessel during an accident, internal exposure by iodine might be beyond the assumed scenario if there is no radiation protective clothing like masks. A base for incident response activities also might have radiation pollution, and as the accident progresses, some areas of the workplace might see a higher dose rate or be polluted locally. Hence, radiation control should manage both external exposure and internal exposure depending on the situation. And working control should assume such a situation beforehand.
- During an accident, the amount of radiation control work might increase abruptly so we should reinforce the system for acting more quickly.
- Since the doctor who stayed in the earthquake-proof principal building had knowledge of emergency exposure medical treatment, he examined two workers who possibly had beta ray burns and swiftly took them to the National Institute of Radiological Sciences. It is an anecdotal experience and we should continuously promote understanding associated with emergency exposure medical treatment.

Measures to take

In light of those described above, the following measures are suggested.

- Prepare materials and equipment such as radiation measuring instruments and radiation protective clothing so as to do adequate radiation control. The following measures are listed for example.
 - Ensure diversification of electric power supplies like battery-operated ones for radiation measuring instruments and enough electric power supplies to use for a long time. Place the required number of batteries in an area unaffected by tsunami. And make a plan arranging to share the required radiation measuring instruments beforehand.
 - Ensure mobile WBC such as WBC on-vehicle, or arrange to use WBC of other facilities.
 - Ensure the required amount of the radiation protective clothing considering the rapid progress of an accident.
- Make the Emergency Operation Facility, which becomes a base for incident response activities during an accident, available on the assumption that radioactive materials exist in the environment. Make sure that all workers know the latest information regarding dose rate and pollution in the workplace with the progress of an accident so that they can fully recognize the importance of exposure dose reduction.
- Reinforce the system to let workers act more quickly to handle the radiation control work which might increase abruptly. For example, request assistance from radiation management workers outside the station, and have workers,

who do not have the knowledge of radiation control, calculate a radiation dose. Such a support system enables radiation management workers to focus on more important operations.

- Prepare to arrange an emergency exposure medical treatment team in case of an accident.

4.10.6 Organization and command or order

Originally the director of a plant can decide to do the vent operation for the containment vessel as written in the internal manual. But in this accident, we needed to ask for government authorization and to negotiate with the local government, when the vent operation became inevitable. External adjustment took time because, for example, we needed to wait until the evacuation had been completed.

And when doing seawater injection at Unit 1, workers proceeded based on the confirmation and agreement of the company president. After that, as a result of discussion between the head office and the power plant, the Station decided to temporarily stop seawater injection, but it was continued based on the judgment of the director of the power plant. There was confusion in the chain of command or order.

Findings and lessons learned

- Regarding emergency measures, in the confusion during emergencies adjustments need to be made with the associated organizations. Therefore, there is a possibility of delay or confusion in making decisions.

Measures to take

In light of those described above, the following measures are suggested.

- Clearly articulate the timing of judgment for the emergency measures that affect badly an accident, and proceed with external adjustment for them at an early date preparing to conduct prompt operations.

4.10.7 Communication

In this incident response activities, due to water exposure by the tsunami and station blackout for a long time, internal PHS or paging devices, which were a form of ordinary communication methods in the field, countermeasures headquarters, and MCR, were hardly used.

Because field workers put on a full range of protective gear such as protective clothing and a full-face mask they had to work in a severe environment and without communicating with one another. Therefore, it was very difficult to do the incident response activities because it took time to confirm the field status and to provide directions for fieldwork.

On the other hand, regarding communication between the power station and outside parties, in fact the leased line network to internal and external organization was available in this accident. But there is always a risk it will be disrupted like the internal network in the power station due to an earthquake, tsunami or such like.

Findings and lessons learned

- The communication methods within the power station and to the outside should be built and maintained by means which are free from the influence of an earthquake or tsunami, and which are capable of using a power supply even when a station blackout occurs for a long time.
- One communication method to be used between field workers and another communication method to be used among field workers, countermeasures headquarters and MCR should be prepared, considering use with a full range of protection gear and the severe environment during an accident.

Measures to take

In light of those described above, the following measures are suggested.

- Countermeasures for communication methods within the power station and to the outside which are free from the influence of an earthquake or tsunami, and which are capable of using power supply even when a station blackout occurs for a long time.
 - Prepare backup power such as battery which is free from the influence of an earthquake or tsunami, and which is independent from the reactor facility.
 - Design facilities used on an emergency basis such as servers, communication equipment like switches, and cable communication lines or wireless staging base so that they cannot easily be disrupted by natural disasters such as an earthquake and tsunami.
 - Deploy multiple communication devices such as leased lines, satellite phones, and wireless lines, and clarify the way they operate.
- Countermeasures for facilitating communication between field workers, or among workers, MCR and Emergency Operation Facility.
 - Deploy the required number of communication devices including those used in the field.
 - Clarify the way to operate the deployed communication devices and improve worker's proficiency through training at the same time.

4.10.8 Environmental monitoring

According to government's "Basic disaster prevention plan," in terms of environmental monitoring at the time of nuclear disaster, business worker takes charge of border line and inside of the site boundary, and mainly local government takes charge of outside of the site boundary.

In this nuclear disaster, regarding environmental monitoring for inside of the site boundary and border line which business worker takes charge of, measurement at MP within the site boundary and on border line became unavailable due to the loss of external power supply caused by tsunami. Therefore, until the external power supply was restored, the environmental monitoring was continued by use of monitoring vehicle, temporary MP and survey meter etc. And the measurement results were released on the Internet as applicable, though it was limited due to manual creation.

In the case of local government's environmental monitoring, environment monitoring equipment and facilities required were not available due to the effect of power outage, communication line disconnection, and local government buildings swept away by the tsunami. And also, the environmental monitoring

activities had a major obstacle because persons in local government had to focus on responding to the earthquake and tsunami that occurred in a wide area, and because the onsite countermeasures headquarters had to move from the offsite center to Fukushima prefectural government. Moreover, related government offices, who were supposed to help local government to execute and support monitoring based on local government's request, were engaged in other earthquake responses such as investigating the great number of missing persons that covered a wide range, so it was difficult to build the environmental monitoring system just after the earthquake.

On the other hand, business workers except those at Tokyo Electric Power Co., Inc. dispatched workers based on an atomic energy cooperation agreement and supported the environmental monitoring outside the site boundary executed by the local government utilizing a monitoring vehicle.

As mentioned above, there were many problems in monitoring facilities and securing workers, but monitoring activities have been done as much as possible. However, some mass media criticized the Station for the delay in releasing monitoring data, and low reliability of offshore monitoring data, and doubted that some of monitoring-vehicle measurement data, which were complementarily measured every 2 minutes by Tokyo Electric Power Co., Inc., were not released.

Findings and lessons learned

Since the entity in charge of environmental monitoring differs depending on whether it is inside or outside the site boundary, we only describe the monitoring executed by business workers.

- Due to the effect of power outage by tsunami, the permanent monitoring facility of business workers became unavailable, so alternative means had to be used.
- Although accepting workers based on the atomic energy cooperation agreement and working with environmental monitoring activities conducted by the local government to do monitoring activities continuously, it took a long time to build the system to do the environmental monitoring under the condition where extensive natural disasters and nuclear accidents occurred at the same time.
- The monitoring data obtained by business workers was released on the Internet or by the mass media if applicable, but from the viewpoint of promptly releasing it and ensuring the reliability of the released data, the Station failed to satisfy the general public and the mass media.

Measures to take

- Public-private partnership such as cooperation and support in the environmental monitoring conducted by the local government, and private-private partnerships such as cooperation among businesses should be reconstructed. Specific details are shown below.
 - Reconfirm the monitoring equipment and facilities that are required to be shared in an emergency, and deploy the required number.
 - Reconsider the workers to be dispatched in an emergency, and clarify rules associated with the dispatch.
- Considering this natural disaster (earthquake, tsunami), the utility used for the permanent MP should be reinforced. Specific details are shown below.
 - Reinforce electric power supply and transmission line

- Reinforce resistance characteristics to an earthquake and tsunami
- Monitoring procedure using alternative means should be clarified in case the permanent MP becomes unavailable. Specific details are shown below.
 - Reconsider the measurement procedure by use of alternative means such as temporary monitoring equipment
 - Confirm the required equipment and facilities by use of alternative means, and deploy them
- Required information and means of transmitting it to the general public, related organizations, and workers involved should be clarified. Specific details are shown below.
 - Streamline the contents of transmitted information, how to coordinate them, and required workers
 - Consider transmitted means (newspapers, websites, etc.) and timing of release

4.10.9 Preparing disaster countermeasures (heavy equipment and rescue), emergency cooperative framework

In this accident, extensive natural disasters and nuclear accidents occurred at the same time. Therefore, it was very difficult to contact and communicate with people, do an emergency call up, and procure goods. The Station was not able to quickly and sufficiently accept the materials and equipment for use in emergency measures or rescue teams who support the accident management activities as the initial reaction to the accident. Also, the high radiation level at the field became an obstacle to human responses. In addition, activities had to be conducted with conditions such as looking out for aftershocks and the following tsunami, darkness, high contamination status, ensuring electric power supply in anticipation of worsening of environmental conditions such as contaminated water, arranging materials and equipment and temporary work, removing blockages so as to let people pass through on and off site. These conditions greatly influenced the following incident response activities.

Findings and lessons learned

- Due to the earthquake and tsunami, routes to access were damaged within and outside the power plant. So it took time to bring in materials and equipment for use in incident response and to call up supporting workers. This hindered smooth incident response activities. Materials and equipment that facilitate working in constrained conditions for various sorts of work were expected.
- Preparations for a multi-unit and coincident accident like this accident were not enough, so that protective clothing, dosimeters and masks for use in incident response were not deployed in an appropriate manner. And having workers work under high radiation for a long time was not assumed specifically. Because there had been no preparation for work under these conditions, incident response was not able to proceed promptly.

Measures to take

In light of those described above, the following measures are suggested.

- On the assumption that routes to access are blocked within and outside the power plant due to natural disasters (earthquake, tsunami), preparing heavy equipment to remove scattered wreckage diversifying workers and means of

transport for materials and equipment are required. Considering cooperation with related organizations, specific details are shown below.

- Clarify and deploy the required heavy equipment except for the wheel loader which was deployed as severe accident countermeasures.
- Establish a means for sea transportation and air transport instead of land transport, and deploy the system.
- We need to ensure the required materials and equipment for use in incident response, and to reconstruct a system to share them among workers on an emergency basis. Considering cooperation with the related organizations, specific details are shown below.
 - Clarify the required materials and equipment based on the incident response of this accident, confirm required number of them, and deploy them (including temporary lights, temporary air conditioning, and temporary drainage equipment).
 - Reconfirm a system to interchange among business workers on an emergency basis and deploy means of interchange.
 - Focus on a remotely-operable facility and equipment (robot, unmanned helicopter) for Nuclear Emergency Preparedness that can work under a high radiation level, participate in review sessions associated with its development and operation, and deploy a cooperative system with workers and related organizations for actual installation.

4.11 Security of integrity of spent fuel

All external power supplies were lost due to the earthquake. However, all emergency DGs were activated excluding one that was undergoing an inspection. However, all of the emergency DGs excluding the 6B emergency DG of Unit 6 were stopped due to the tsunami that hit the power station afterwards. In addition, the cooling function of the spent fuel pool was lost in all units because the function of the seawater pump was lost due to the tsunami.

Further, we consider that there is no exposure of fuel in the spent fuel pool.

Findings and lessons learned

- When the cooling function of the spent fuel pool was lost, it is extremely important to keep the water level of the spent fuel pool at a safe level, and maintaining and strengthening the water level of the spent fuel pool and the monitoring function of the pool water temperature are also important.
- There is a need to prevent the pool water level from falling and the spent fuel being damaged followed by the loss of the spent fuel pool's cooling function. Hence, in the wake of this accident, we consider that new countermeasures have to be additionally prepared in order to maintain the cooling function of the spent fuel pool at the time of a station blackout in a number of units including adjacent units and when the function of the seawater pump is lost.

Measures to take

In light of those described above, the following measures are suggested.

- It is necessary to secure an alternative coolant injection means to secure the water level of the spent fuel pool.
 - Supplying water by fire engines, pump trucks, and such like and securing a coolant injection route and a water source

- It is necessary to secure and strengthen the water level of the spent fuel pool and the monitoring function of the pool water temperature.
 - Securing the power source supply from the emergency power source to the water level meter and the thermometer of the spent fuel pool
 - Strengthening the monitoring function of the status of the spent fuel pool (connection of the emergency power source to the ITV, battery connection, etc.)
- It is necessary to investigate the maintenance of the cooling function of the spent fuel pool water as a continuous cooling means after the water level has been secured.
 - Securing the alternative cooling function of the spent fuel pool water.

4.12 Summary of countermeasures

As described in Chapter 3 “Analysis of Causes of Accident Events and Extraction of Problems,” to prevent reoccurrence of the accident it is important to increase the safety margin by assuming that an accident will escalate and by preparing for it by taking appropriate countermeasures.

The profoundness of the system of countermeasures is summarized and outlined in Table 4.12-1 by combining the countermeasures that have already existed and the countermeasures that are exemplified here as new countermeasures.

In the causal analysis, the main cause of the accident escalating was the loss of the power supply, and it was described that the safety components stopped working due to the loss of the power supply. Therefore, we decided to confirm the status of the system of countermeasures regarding the power supply. Further, there was a loss of a heat sink (including the auxiliary component cooling system) as a main factor that meant the safety components other than the power supply stopped working. We also confirmed matters from that viewpoint. Furthermore, we confirmed the situation about hydrogen because the hydrogen explosion largely affected the discharge and diffusion of radioactive materials in addition to hindering the Station’s response to the accident.

The countermeasures are outlined, and basically the following approach can be taken.

First, the Station can attempt to resolve an assumed major accident at the stage of designing the countermeasures with the safety components (the seawater pump, the emergency DG, the ECCS, etc.) that have been already installed. Reviewing what happened this time, we shall further protect these safety components that have been already installed.

The existing safety components have multiplicity and diversity. Severe accident countermeasures (accident management) were prepared independently at each nuclear power station in the 1990s by assuming a case where the functions of all these safety components was lost. In the Fukushima Daiichi accident, most of the accident management could not be applied due to various constraints such as the loss of the power supply and high contamination. Because of this, countermeasures for smooth application shall be considered.

Because this accident management did not sufficiently function, we shall prepare severe accident countermeasures that will be added this time.

Therefore, as shown in the confirmation table, selectively treating the countermeasures means further protecting the existing safety systems and additional severe accident countermeasures.

In such way, a layered protection system can be prepared by adding severe accident countermeasures to the existing safety components and to the accident management components. We consider this will become an effective countermeasure for preventing the accident from progressing.

- Power Supply

The power supply shall be secured surely against an earthquake and tsunami by layered countermeasures.

- The power is supplied by an external power supply during a blackout in the conventional design. However, the power supply is supplied by an emergency DG when external power supply is also lost. This power supply protects these functions.
- Assuming a case where these functions are lost, the power supply is supplied by an alternative means such as a power supply vehicle.
- Valves and such like are individually operated by deploying a storage battery or such like.

- Heat sink (coolant injection and cooling)

Layered countermeasures shall ensure the core is cooled without fail when an accident occurs.

- The seawater system and the ECCS component that are expected to prevent an accident from escalating in the conventional design shall be protected.
- Spares for the seawater system are deployed as countermeasures when the protection is breached. These are protected by the facility of severe accident countermeasures (accident management) against the loss of the function of the ECCS.
- Considering a case where these do not function effectively, a pump that can separately inject water is deployed and the water source is secured. Countermeasures shall be taken for reducing the RPV pressure to secure the injection of water.
- Furthermore, countermeasures shall be taken in the BWR for certainly performing a container vent that is a final cooling means when an accident escalates.

- Countermeasures for a hydrogen explosion

An explosion shall be prevented by countermeasures for each stage of the event such as prevention of hydrogen generation, prevention of leakage, and reduction of discharge.

- The generation of hydrogen due to damage to the fuel is prevented in the conventional design by securing the cooling of the core. Also, an explosion is prevented in the BWR by confining the generated hydrogen in a container

having a nitrogen atmosphere. Therefore, the countermeasures of the water injection and cooling are effective also as countermeasures for hydrogen.

- Hydrogen is generated when the core is damaged. However, countermeasures are taken for discharging or reducing hydrogen so that it does not stay in the building by considering that hydrogen leaks from the container because hydrogen easily leaks.
- Countermeasures are taken to prevent the leaked hydrogen from wraparound other units from a vent line.

Specifically for investigating (adapting and combining) other layered countermeasures, it is effective to consider issues such that:

- an appropriate balance shall be taken among the prevention of core damage, the prevention of container damage, and the degree of prevention,
- we shall not be biased toward administrative measures,
- protection against possible common causal factors shall not be decreased and new common causal factors shall not be induced,
- independency of barriers shall not be decreased,
- preparation for human error shall be maintained, and
- functions that are planned in a plant's design standard shall be secured.

In order to determine priority among individual countermeasures, the following criteria shall be used.

- Means such as the UHS and the power supply which have an effect and influence on a larger number of functions are more important.
- The means and the measures having a larger contribution to the "thickness" of layers have higher priority.
- Qualitatively, an individual step is considered to become more important as the number of steps decreases.

For example, a step that is added to one existing step is more important than a step that is added to two existing steps.

The layers of the countermeasures that are prepared are determined depending on the extent of possible internal and external hazards and failures.

By combining various countermeasures at this time with the countermeasures that have been considered at the stage of designing and constructing, the layered countermeasures shall be taken that are sufficiently effective for securing safety and for effectively preventing an accident where a large amount of radioactive material is discharged to the environment even when the prepared functions are lost one by one.

As a result of outlining the points as described above, countermeasures that are considered to have high priority from the viewpoint of preventing reoccurrence of the accident among the 80 countermeasures exemplified in the present investigative commission are identified in a table. We suggest that these items be adopted when each company implements countermeasures.

- Power supply

- Establishment of a tide embankment and breakwater for a facility that is important for safety
 - Prevention of inundation of the area where components that are important for safety are provided
 - Prevention of inundation, including improving sealing capability at openings and penetration of an air supply port, depending on the inundation height
 - Water tightening of the sites where the transformer for receiving and the switchyard are arranged, or countermeasures for inundation of the components
 - Water tightening of the sites where the D.C. power supply system is arranged, or countermeasures for inundation of the components
 - Deployment of a power supply vehicle or a power supply having a large capacity (a gas turbine or a diesel generator) and preparation of its emergency procedure
 - Preparation of a DC power supply charging route by the backup power supply
 - Improvement of reliability by countermeasures for inundation of the facility that accommodates a power supply between the Units (severe accident countermeasures)
- Heat sink (water injection and cooling)
- Measures for preventing inundation of a bulkhead and such like around the seawater pump
 - Disposition of spares for the seawater pump
 - Prevention of inundation of areas where safety components such as the emergency core cooling system are installed
 - Prevention of inundation of the facility for severe accident countermeasures
 - Disposition of a movable coolant injection pump
 - Preparation of the backup power supply for driving the SRV, spare air cylinders, etc. (BWR)
 - Security of the core cooling through the SG by an Atmospheric Dump Valve (PWR)
 - Disposition of a backup power source for operating a vent and a driving source (BWR)
 - Improvement of reliability of the existing coolant injection system by deployment of a backup power supply vehicle and a power supply having a large capacity
 - A portable power pump, hose, and such like that do not depend on the existing facility
 - Security of the water source
 - Releasing heat to the air by the container vent (BWR)
- Hydrogen
- Discharge and decrease of remaining hydrogen
 - Prevention of wraparound of hydrogen from a pressure resistant strengthened vent line

- Prevention of wraparound of hydrogen between the Units sharing an exhaust pipe

Further, countermeasures are combined by considering the safety of the plant as a whole and selecting countermeasures for implementation. Various combinations of countermeasures can be considered corresponding to the condition of each power station and the strategy for securing safety, and they are not limited to the above-described countermeasures. All countermeasures that were identified are summarized and shown in Fig. 4.12-1.

Table 4.12-1 Checklist gathered together from the standpoint of defense in depth

			Preventing the occurrence of accidents / Reducing the accident impact				
Level of defense in depth			First layer (Preventing the occurrence of abnormalities)	Second layer (Preventing the expansion of abnormalities and prevention of leading to accidents)	Third layer (Preventing the abnormal release of radioactive materials)	Fourth layer (Preventing the occurrence of severe accidents)	Fifth layer (Reducing the severe accident impact)
Purpose			Preventing abnormal operations and faults	Controlling abnormal operations and detecting faults	Controlling accidents within design criteria	Preventing the progression of accidents	Reducing the SA impact
Essential means			Conservative design and construction High quality in operation	Control, limitation and protection system	ECCS and emergency operating procedures	Supplementary measures and severe accident management	Supplementary measures and severe accident management including PCV protection
Reactor core	Power sources	Before earthquake disaster	<ul style="list-style-type: none"> Set the seismic class on the assumption of a sufficiently conservative design based on records of the past and designed the ground height providing about a double margin. Did not consider the possibility of entry of water through openings such as the building's air supply/exhaust ports due to tsunami. Distribute power from external power source when the plant stops power generation. Installed an emergency DG with redundancy and back up with the emergency DG if the external power source is lost. Assumed that power will be restored in a short time even if a power failure occurs. Deployed multiple systems of varied power sources by the external power source system, emergency DG, and DC batteries to secure the diversity and redundancy of power sources. 	<ul style="list-style-type: none"> Upon detecting a voltage low signal of the high-voltage power bus, the emergency DG will automatically start. Upon the automatic start of the emergency DG, the related equipment will start sequentially. 	<ul style="list-style-type: none"> Upon receipt of an automatic start signal of the ECCS pump, the emergency DG will automatically start regardless of the supply of external power source. Secure power source by the emergency DG with redundancy and DC batteries. 	<ul style="list-style-type: none"> Expect to restore AC power supply early (in about 8 hours), not assuming a long period of power failure. After the AC power supply is lost, carry out core cooling by DC-driven equipment and expect to restore AC power supply. Preparation of restoration procedures 	<ul style="list-style-type: none"> Prepare power sharing between units for severe accident management. However, simultaneous loss of power at multiple units is not assumed.
		Proposed measures	<ul style="list-style-type: none"> Construct a coastal levee or breakwater for equipment important to safety. Prevention of inundation of sections where equipment important to safety is installed Prevention of inundation by improving sealing performance for the openings such as air supply opening and penetrations according to the inundation height Making watertight places where the power receiving transformer and switchyard are allocated or anti-inundation measures for equipment Making watertight the section where the DC power supply system is allocated or preventing inundation of equipment 			<ul style="list-style-type: none"> Deployment of power-supply vehicles or high-capacity power supplies (gas turbine and diesel generator) and preparation of emergency procedures Preparation of a DC power supply charging route by a backup power supply Deployment of portable drain pumps, and such like 	<ul style="list-style-type: none"> Reliability improvement by anti-inundation measures for power sharing equipment between units (severe accident management)
	Heat sink (Water injection, cooling)	Before earthquake disaster	<ul style="list-style-type: none"> Set the seismic class and ground height on the assumption of a sufficiently conservative design based on records of the past Installed the heat removal system with redundancy. Secured redundancy or diversity and independence of the heat removal system. 	<ul style="list-style-type: none"> Operation makes it possible to deal with transients without expecting safety system equipment such as ECCS. Did not assume simultaneous loss of all functions of the seawater pump and power panel due to inundation. If the seawater pump trips, a spare pump will automatically start. Detectors relating to the safety of the reactor have been designed to be tested even during operation of the reactor so that maintenance of integrity and redundancy can be checked 	<ul style="list-style-type: none"> Installed multiple safety system lines such as ECCS. Power is supplied through the emergency DG even if external power source is not available. Installed systems (IC, HPCI, RCIC) that can function by power supplied from DC batteries even if the AC power supply is lost for a short time. Secured diversity for driving source by installing steam-driven equipment. Although there are HPCI and RCIC that do not require the seawater cooling system for cooling oil and bearings, their functions will be lost once DC power supply has become unavailable. 	<ul style="list-style-type: none"> Maintain severe accident management. Use existing equipment as alternative water injection equipment as required. Did not assume a long period of loss of power and inundation. No alternative driving sources for valves 	<ul style="list-style-type: none"> Arrangement of connecting ports to fire protection system piping
		Proposed measures	<ul style="list-style-type: none"> Take measures to prevent inundation around the seawater pumps by waterproof barriers, and such like. Prevention of inundation for sections where safety equipment such as the core standby cooling system, and such like is allocated 		<ul style="list-style-type: none"> Improving reliability of the existing injection system by deploying a backup power-supply vehicle or high-capacity power supply Preparation of a backup power supply for driving the SRV, spare air cylinders, and such like (BWR) 	<ul style="list-style-type: none"> Deployment of spare seawater pump motors Deployment of washing and drying materials for seawater pump motors Deployment of mobile (immersion-type, etc.) seawater pumps Prevention of inundation of equipment for severe accident management Portable power pumps, hoses, and such like without depending on the existing power supply Securing water sources Deployment of a backup power supply and driving source for vent operation (BWR) Securing core cooling by the main steam relief valve through the SG (PWR) 	<ul style="list-style-type: none"> Releasing heat into the air by containment venting (BWR)
	Hydrogen	Before earthquake disaster			<ul style="list-style-type: none"> Installed the flammable gas control system to control the density of hydrogen generated at the time of loss of coolant accident and oxygen. Prevention of the generation of hydrogen by core cooling with ECCS, and such like Inject nitrogen into the PCV to create an inert environment, thereby controlling the density of hydrogen and oxygen in the containment in an accident environment, below the inflammable limit. 	<ul style="list-style-type: none"> Did not consider the wraparound of gas between units. 	<ul style="list-style-type: none"> If the reactor core is damaged, hydrogen could leak from the containment.
		Proposed measures				<ul style="list-style-type: none"> Release and reduction of retained hydrogen Prevention of wraparound from the enhanced pressure resistant vent line Prevention of hydrogen wraparound between units sharing the stack 	<ul style="list-style-type: none"> Release and reduction of retained hydrogen
SFP	Injection/cooling, power source, water level	Before earthquake disaster	<ul style="list-style-type: none"> Installed equipment sufficiently capable of cooling for decay heat of the maximum storage capacity. 	<ul style="list-style-type: none"> Designed the piping takeoff height to be above the required water level so that the required water level will be maintained even when piping leaks due to a siphon break, and such like. Have a supply function from the seismic class S water source. Water is supplied from the water supply system to maintain the water level. 	<ul style="list-style-type: none"> Did not assume loss of means of cooling. 		
		Proposed measures			<ul style="list-style-type: none"> Securing a water injection route by fire trucks, and such like and securing a water source 	<ul style="list-style-type: none"> Securing an alternative cooling function (or early recovery of the component cooling system) 	

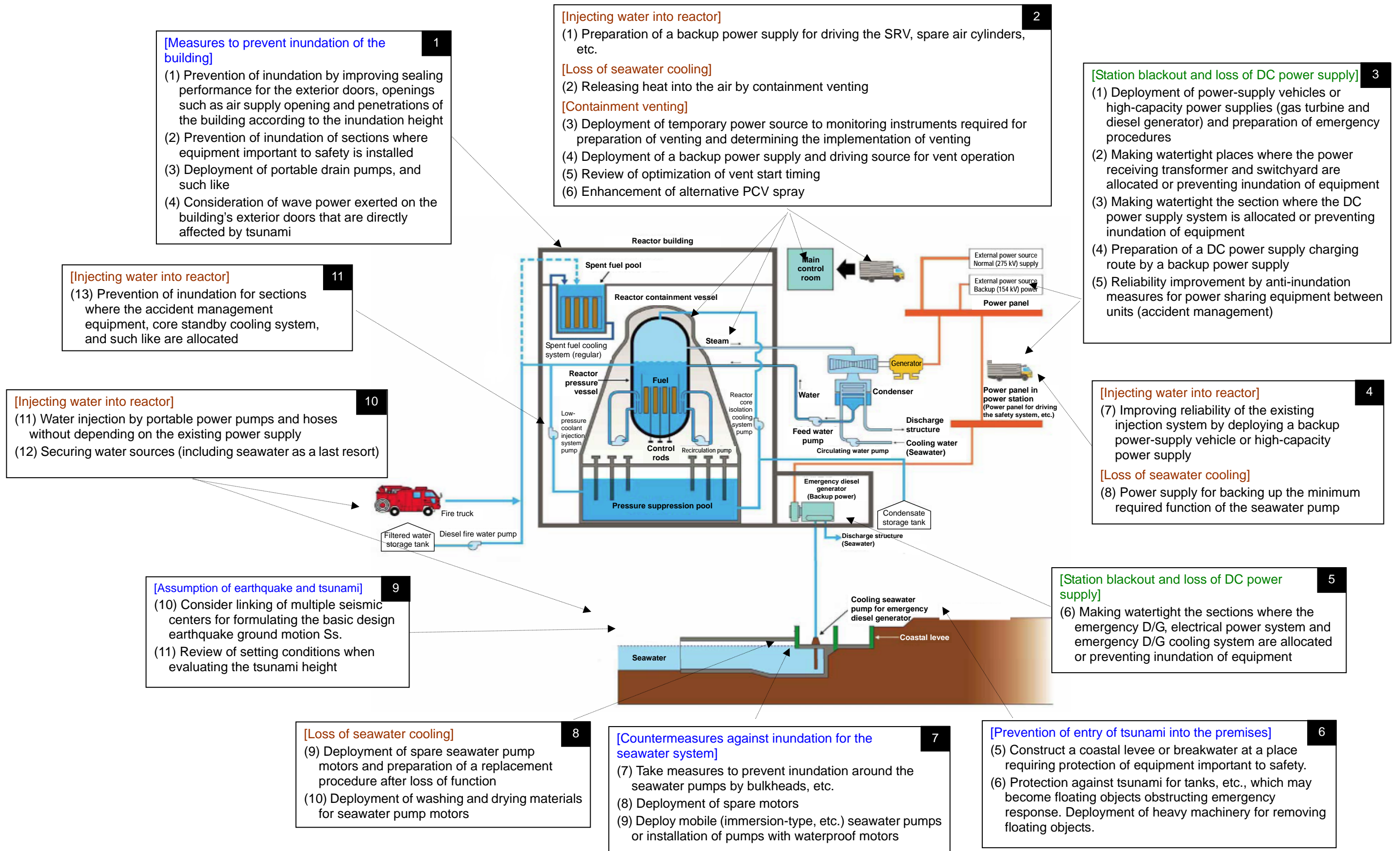

Fig. 4.12-1 Countermeasure example 1/3

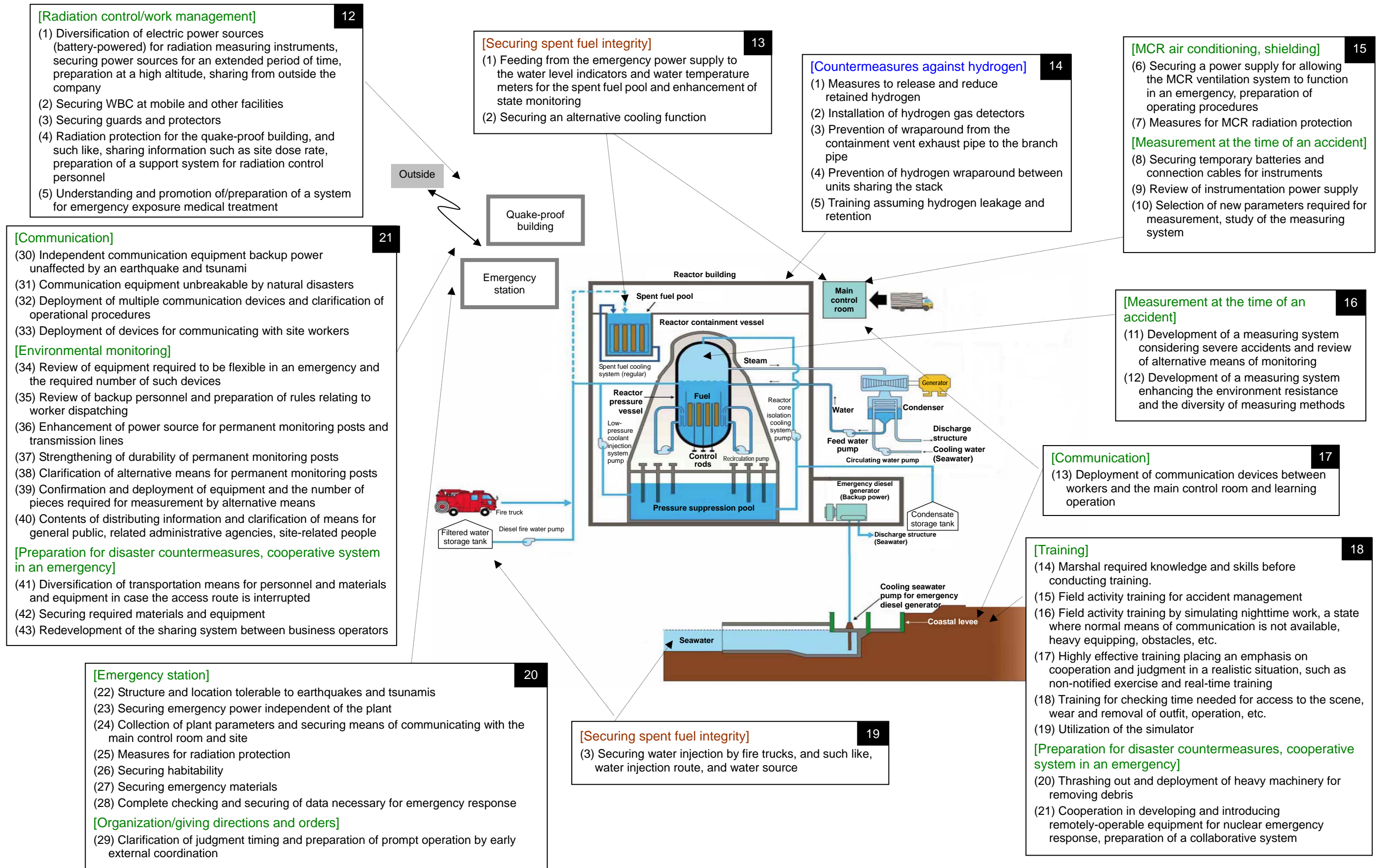

Fig. 4.12-1 Countermeasure example 2/3

Other countermeasures (preparation for earthquakes and tsunamis, preparation of power sources, countermeasures against hydrogen, etc.) are the same as for the BWR.

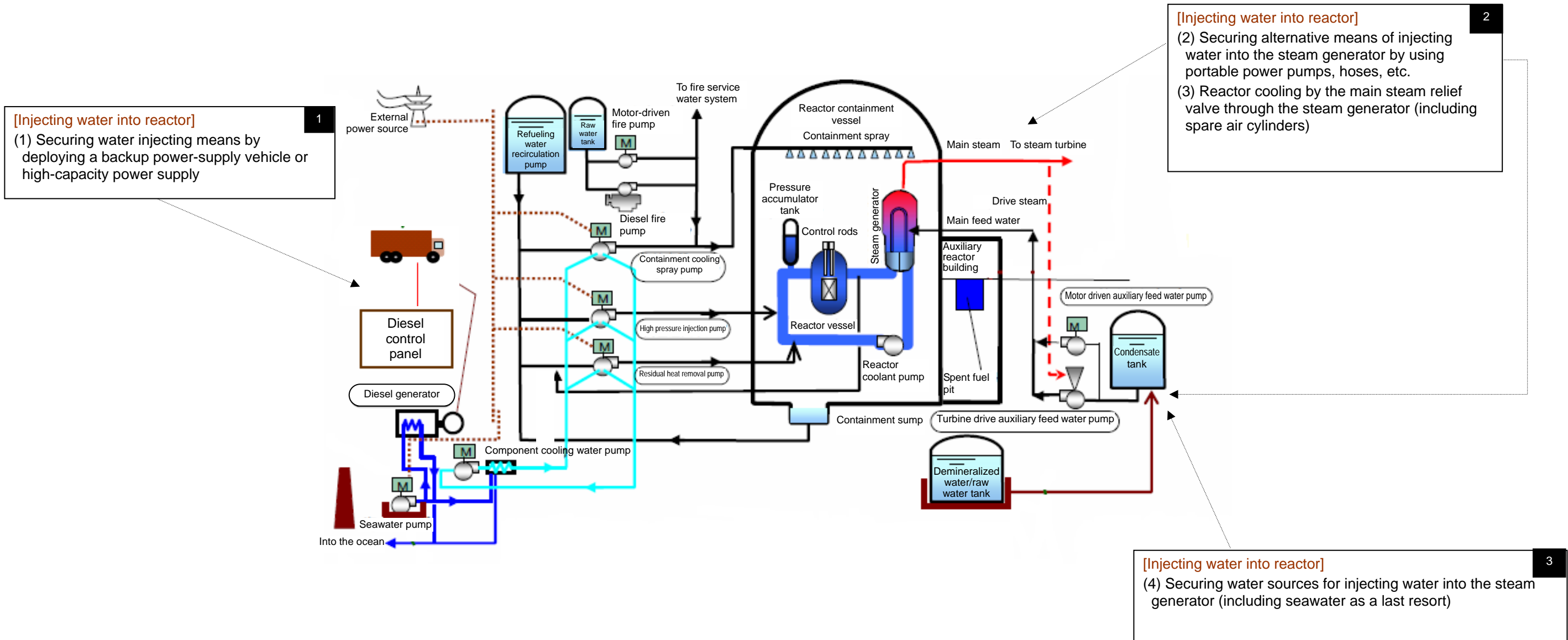

Fig. 4.12-1 Countermeasure example 3/3

Chapter 5 Timeline of Accident to the Present

The Great East Japan Earthquake which occurred at 14:46 on March 11, 2011 struck the Fukushima Daiichi and Daini Nuclear Power Stations, a long-term nuclear accident of an unprecedented scale.

In Units 1 to 3 of the Fukushima Daiichi Nuclear Power Station, workers remained unable to inject water into the RPV for a period, exposing the fuel in the cores and leading to a core meltdown. A portion of the melted fuel pooled below the RPV.

A large quantity of hydrogen was produced from a chemical reaction between zirconium in the cladding and other fuel rod parts and steam, the fuel rod cladding was damaged, radioactive materials in the fuel rods were released into the RPV, and hydrogen and radioactive materials were released into the storage container during the RPV decompression process.

The internal pressure in the RPV that lost core cooling functionality rose and leaked into the storage container through the safety valve, raising the pressure inside the storage container. To prevent damage to the containment buildings of Units 1 to 3, they were vented to the wet wells several times.

After the wet well venting of the Units 1 and 3, an explosion thought to be caused by hydrogen leaking from the containment building occurred in the upper part of the reactor building and the operation floor collapsed.

An explosion which appears to have been caused by hydrogen occurred in the reactor building of the Unit 4, destroying the upper portion of the building. Around 6:00 on March 15, the sound of a large impact was confirmed, but at this time, it is not clear whether this was due to a hydrogen explosion, or the location where it occurred. Nearly simultaneously, the S/C pressure indicated 0 MPa (abs), and the reason for that is unclear.

Cooling of the spent fuel pools for Units 1 to 4 was shut down due to the loss of power, and the evaporation of water due to heat from the spent fuel caused the water level to continue to drop. To address the water level, helicopters and spray vehicles were used to inject water into the spent fuel pools, though ultimately a concrete pump truck was secured, which pumped seawater, followed by freshwater.

On March 11, the government declared a nuclear emergency situation and established a Nuclear Emergency Response Headquarters and a Local Nuclear Emergency Response Headquarters, with the prime minister serving as the director-general. Further, on March 15, the Accident Measures Integration Headquarters was established to integrate efforts of the government and nuclear workers.

On March 11, the Nuclear Emergency Response Headquarters set the area within a 3 kilometer radius from Fukushima Daiichi as an evacuation zone and the area within a 3 to 10 kilometer radius as an indoor evacuation zone. On March 12, with subsequent development of the accident, the area within a 20 kilometer radius was established as an evacuation zone and on March 15, the area within a 20 to 30 kilometer radius as an indoor evacuation zone. On April 21, the area within a 20 kilometer radius was established as a no-entry zone, with only restricted entry allowed.

Although the Local Nuclear Emergency Response Headquarters was initially established off-site, it was subsequently moved to the Fukushima Prefectural Office

when the location subsequently became a high-radiation environment, causing communication interruptions and impeding logistics.

The provisional assessment of the accident according to the INES was initially a level 3 due to the Station's determination that there was insufficient water in the emergency core cooling system on March 11. On March 12, this was raised to level 4 due to the state of radioactive material emissions, and on March 18, it was raised to level 5 in response to an increase in the quantity of radioactive material being emitted. On April 12, the total quantity of emitted radioactive material was determined to be roughly one-tenth of that of Chernobyl, and the level was raised to level 7.

As a result of the station blackout at Fukushima Daiichi, the internal Personal Handy-phone System (PHS) and Safety Parameter Display System (SPDS) for ascertaining station status became non-functional.

The Emergency Response Support System (ERSS) for predicting nuclear core status and developments during a nuclear accident was unable to obtain the required station information and was otherwise unable to perform its primary functions. Further, the System for Prediction of Environmental Emergency Dose Information (SPEEDI) could not acquire emission source data or otherwise perform its primary function of making quantitative predictions, including how the concentration of radioactive materials in the atmosphere would change.

Towards restoration of the power facilities, power supply vehicles from all branches were dispatched to Fukushima Daiichi; however, progress was impeded by road damage and traffic congestion. Air transport of the power supply vehicles could not be provided by the Self-Defense Forces because the power supply vehicles were beyond their weight capacity. Before daybreak on March 12, power supply vehicles that had been secured were used and cables laid with the aim of restoring power. On March 15, external power was restored to the internal switchyards for Units 1 and 2, and on March 24, MCR lighting was restored for Unit 1, and on March 26 for Unit 2. Further, on March 18, external power was restored to the mobile M/C installed on the Unit 3 premises, and on March 22, MCR lighting was restored for Unit 3.

Taking into account the records collected from MCR and other locations as well as the operating status of equipment, a Modular Accident Analysis Program (MAAP) composed of severe accident analysis code was used to assess the status of the reactor core, and found that in the most rapid scenario, fuel exposure began approximately two hours after the tsunami struck and approximately three hours after the earthquake struck, with core damage occurring about one hour after that. As no water was being injected into the nuclear core at that time, melting of the fuel progressed, and when water injection commenced around 06:00 on March 12, the melted fuel had already migrated to the lower part of the RPV, and apparently leaked to the containment vessel.

At Unit 2, fuel exposure apparently began approximately four hours after 13:25 on March 14, when it was determined that the RCIC shut down, approximately 75 hours after the earthquake struck, followed by damage to the core approximately two hours later. At Unit 3, fuel exposure apparently began approximately four hours after 02:42 on March 13 when it was determined that the HPCI shut down, approximately 40 minutes after the earthquake struck, followed by damage to the core approximately two hours later.

With regards to stable cooling of the nuclear reactors, before carrying out the flooding operation (filling the containment vessel with water up to the upper fuel

region) initially planned, a review was made and it was decided to establish a “recycled water injection cooling” to process contaminated water that had been accumulated in the reactor building for reuse as nuclear reactor injection. Additionally, the reliability of the injection water was ensured (with measures to address abnormalities and multiple water injection methods), a hydrogen explosion was avoided through filling the containment vessel with nitrogen, and “stable cooling,” the second step of the road map, was reached.

Currently, the temperature of each part of the RPV has been stably shifting, and the temperature of the bottom portion of the RPVs at Units 1 and 3 is stable at no greater than 100°C. The quantity of injection water was experimentally varied at Unit 2, and a stable temperature of no greater than 100°C was confirmed for the bottom portion to the RPV.

Concerning cooling of the spent fuel pools, a heat exchanger was used for circulating cooling at all Units, 1 to 4, and by August 10, “more stable cooling,” step 2 of the road map, was achieved.

Seawater and underground water from the tsunami, as well as water injected into the nuclear reactor and spent fuel pools leaked, resulting in an accumulation of highly radioactive water in the reactor building, which leaked to the cable trenches outside and then to the ocean from cracks in the concrete frame. Measures were taken to prevent leakage to the ocean, including capping the trenches and stopping the water; additionally, treatment equipment was installed to treat the accumulated water so that the water level would not overflow. To carry out treatment of the accumulated water and inject it into the nuclear reactor in a stable, efficient manner, a liquid waste concentrate system was put into service on August 7 as a second line of treatment equipment to increase the desalting capacity, and the operation moved forward smoothly. On October 9, the augmentation of the salt treatment equipment with a liquid waste concentrate system was completed, making nuclear reactor water injection more stable.

Currently, progress is at the second step of the road map, and work on measures to control the release of radioactive materials is progressing.

Chapter 6 Conclusion

The accident at the Fukushima Daiichi Nuclear Power Station has caused distrust in nuclear power not only in Japan but around the world as well.

Cause analysis and recommendations for action have been provided by a variety of agencies, including a national accident measure commission. In this report, electrical workers having the primary responsibility for construction and operation of nuclear power stations have worked with electrical engineers directly involved with the design and construction of Power Stations, voluntarily summarizing the results of their impartial analysis of the causes of the accident, their deductions of the most significant lessons to be learned, and countermeasures they have considered.

Japan Nuclear Technology Institute (JANTI) is composed of many companies involved in the nuclear power industry as well as electrical workers, and through this association, power engineers and Plant engineers have been able to come together to hold discussions. The positions of power production and Plant construction were separated, and the abilities of experienced specialists were employed to objectively study the issues from an engineering perspective to further delve into the results that were assembled by the power and Plant specialists. These efforts were also reflected in this report.

Furthermore, specialists of the technical analysis subcommittee of the Atomic Energy Society of Japan (AESJ) have provided a review of this report, providing additional perspectives.

Central to this investigation have been the cause analysis into why it was not possible to avoid a core meltdown at the Fukushima Daiichi Nuclear Power Station after the tsunami struck and proposals for countermeasures. In short, the factors may be summarized as being that due to the tsunami, the cooling, control and monitoring functions of the internal electrical equipment, particularly the emergency AC and DC electrical panels were lost due to incoming water, and that due to the time required to establish a reactor core cooling means as an alternative to the regular power supply, flooding of the reactor core could not be maintained. At Power Stations around Japan, emergency safety measures have already been implemented for the present to prevent incidents caused by tsunamis, and through this investigation, multilayered countermeasures have been deduced, including those already implemented in Power Stations throughout Japan and those planned for implementation.

In this investigation, however, it was not possible to directly interview the workers working at the time of the accident. By conducting an investigation with the focus on finding room for improvement, if only to alleviate the burden on the Station workers, the experience of operating during such an emergency situation could likely be used to acquire knowledge useful in further improving measures against other incidents.

Recommendations in this investigation on alleviating the effects of post-meltdown radioactive materials on the environment, estimates and criteria of the quantity of radioactivity that people in the vicinity were exposed to, measures for resident evacuation facilities, and disaster-related matters such as information dissemination and disclosure, and a system for instructions and orders were based solely on information obtained from the industry. In relation to these matters, however, there are likely to be many issues that ought to be reconsidered and many lessons to be learned when the perspectives of people in the local communities and others are taken into consideration, and those issues should be the focus of investigations going forward.

When engineers design facilities, they must ensure that certain conditions, including regulations, are satisfied. The thinking of the people who set those conditions is susceptible to various influences, and phenomena may occur that exceed those conditions. Given this premise, it may be that the most important lesson that nuclear power engineers should learn from this accident is that they should appreciate anew the importance of continuing the search for rational means to solve engineering issues. Particularly when your adversary is a natural phenomenon such as a tsunami, it is critical to take yet another look at whether any of a variety of methods are needed to minimize the effects of a phenomenon should it exceed expectations. Deep consideration should also be given to the import of the words, "The prime responsibility for safety must rest with the organization" in the IAEA's Fundamental Safety Principals. Moreover, it is surely the responsibility of the engineer to continuously and repeatedly question safety without being under the illusion that satisfying regulatory requirements is an adequate discharge of one's duties, and we should demand that nuclear engineers recall what their purpose is as an engineer.

Whether such investigations will be conducted with due seriousness and without getting caught up in the past, and whether the results of those investigations will be reflected in Stations to improve safety is truly something to be decided by the ability of the nuclear power industry and each and every nuclear engineer. It is hoped that the industry and engineers will return to the roots of their calling as engineers and move forward in making on-going improvements.

The investigation described in this report was conducted based on information currently available, as described above, and was carried out with our best efforts. When others view the report from their various perspectives, they will likely notice many oversights and consider measures superior to those offered here. We hope that the reader will subject this report to the strictest of scrutiny and point out all such shortcomings.

In closing, as members of the Examination Committee on Accident at Fukushima Daiichi Nuclear Power Station, we would like to express our deep gratitude to all of those who earnestly participated in the long, frequent discussions despite the heavy workload that dealing with the accident entailed for all concerned.

Appendix 1 Countermeasure implementation situation at present nuclear power stations

So far, each utility company has implemented various countermeasures according to the government's instructions described below and further implemented additional countermeasures on their own. The implementation situation is described below.

Government's instructions

- March 30, 2011 "Implementation of emergency safety measures at other nuclear power stations in the light of Fukushima Daiichi/Daini Nuclear Power Station's accident"
 - Securing alternative power sources, preparation of recovery measures for an agile heat removal function, and such like
- April 15, 2011 "Assuring reliability of the external power supply for nuclear power stations and reprocessing facilities"
 - Connection of each unit to all power lines
 - Strengthening of the transmission tower
 - Anti-inundation measures for the switchyard
- June 7, 2011 "Implementation of measures to handle an severe accident at other nuclear power stations in the light of Fukushima Daiichi Nuclear Power Station's accident in 2011 (instructions)"
 - Securing the working environment of the main control room, securing the means of communication in on site of the power station in an emergency, securing the materials and equipment such as high-dose protective suits, arrangement of a system for radiation control, measures to prevent hydrogen explosion, deployment of heavy machinery for removing debris

Using the confirmation table in 4.12-1 where countermeasures are gathered together in "4.12 Summary of countermeasures," the implementation situation of each countermeasure at a representative plant is shown in Appendix 1-1. Many of the items have already been implemented and the remaining items are in implementation or being planned. In this way, each firm has already been steadily implementing various countermeasures.

Short-time countermeasures taken by each utility firm are summarized in Table Appendix 1-2. They are implementing their countermeasures ahead of time.

Table Appendix 1-1 Confirmation table gathered together from the standpoint of defense in depth

Level of defense in depth		Preventing the occurrence of accidents / Reducing the accident impact					
		First layer (Preventing the occurrence of abnormalities)	Second layer (Preventing the expansion of abnormalities and prevention of leading to accidents)	Third layer (Preventing the abnormal release of radioactive materials)	Fourth layer (Preventing the occurrence of severe accidents)	Fifth layer (Reducing the severe accident impact)	
Purpose		Preventing abnormal operations and faults	Controlling abnormal operations and detecting faults	Controlling accidents within design criteria	Preventing the progression of accidents	Reducing the SA impact	
Essential means		Conservative design and construction High quality in operation	Control, limitation and protection system	ECCS and emergency operating procedures	Supplementary measures and severe accident management	Supplementary measures and severe accident management including PCV protection	
Reactor core	Power sources	Before earthquake disaster	- Set the seismic class on the assumption of a sufficiently conservative design based on records of the past and designed the ground height providing about a double margin. - Did not consider the possibility of entry of water through openings such as the building's air supply/exhaust ports due to tsunami. - Distribute power from external power source when the plant stops power generation. - Installed an emergency DG with redundancy and back up with the emergency DG if the external power source is lost. - Assumed that power will be restored in a short time even if a power failure occurs. - Deployed multiple systems of varied power sources by the external power source system, emergency DG, and DC batteries to secure the diversity and redundancy of power sources.	- Upon detecting a voltage low signal of the high-voltage power bus, the emergency DG will automatically start. - Upon the automatic start of the emergency DG, the related equipment will start sequentially.	- Upon receipt of an automatic start signal of the ECCS pump, the emergency DG will automatically start regardless of the supply of external power source. - Secure power source by the emergency DG with redundancy and DC batteries.	- Expect to restore AC power supply early (in about 8 hours), not assuming a long period of power failure. - After the AC power supply is lost, carry out core cooling by DC-driven equipment and expect to restore AC power supply. - Preparation of restoration procedures	- Prepare power sharing between units for severe accident management. However, simultaneous loss of power at multiple units is not assumed.
		Proposed measures	○ Construct a coastal levee or breakwater for equipment important to safety. ● Prevention of inundation of sections where equipment important to safety is installed ○ Prevention of inundation by improving sealing performance for the openings such as air supply opening and penetrations according to the inundation height ● Making watertight places where the power receiving transformer and switchyard are allocated or anti-inundation measures for equipment ● Making watertight the section where the DC power supply system is allocated or preventing inundation of equipment			● Deployment of power-supply vehicles or high-capacity power supplies (gas turbine and diesel generator) and preparation of emergency procedures ● Preparation of a DC power supply charging route by a backup power supply ● Deployment of portable drain pumps, and such like	○ Reliability improvement by anti-inundation measures for power sharing equipment between units (severe accident management)
	Heat sink (Water injection, cooling)	Before earthquake disaster	- Set the seismic class and ground height on the assumption of a sufficiently conservative design based on records of the past - Installed the heat removal system with redundancy. - Secured redundancy or diversity and independence of the heat removal system.	- Operation makes it possible to deal with transients without expecting safety system equipment such as ECCS. - Did not assume simultaneous loss of all functions of the seawater pump and power panel due to inundation. - If the seawater pump trips, a spare pump will automatically start. - Detectors relating to the safety of the reactor have been designed to be tested even during operation of the reactor so that maintenance of integrity and redundancy can be checked.	- Installed multiple safety system lines such as ECCS. - Power is supplied through the emergency DG even if external power source is not available. - Installed systems (IC, HPCI, RCIC) that can function by power supplied from DC batteries even if the AC power supply is lost for a short time. - Secured diversity for driving source by installing steam-driven equipment. - Although there are HPCI and RCIC that do not require the seawater cooling system for cooling oil and bearings, their functions will be lost once DC power supply has become unavailable.	- Maintain severe accident management. Use existing equipment as alternative water injection equipment as required and already arranged the containment enhanced pressure resistant venting. - Did not assume a long period of loss of power and inundation. - No alternative driving sources for valves	- Arrangement of connecting ports to fire protection system piping
		Proposed measures	○ Take measures to prevent inundation around the seawater pumps by waterproof barriers, and such like. ● Prevention of inundation for sections where safety equipment such as the core standby cooling system, and such like is allocated		● Improving reliability of the existing injection system by deploying a backup power-supply vehicle or high-capacity power supply ● Preparation of a backup power supply for driving the SRV, spare air cylinders, and such like (BWR)	○ Deployment of spare seawater pump motors ● Deployment of washing and drying materials for seawater pump motors ● Deployment of mobile seawater pumps ○ Prevention of inundation of equipment for severe accident management ● Portable power pumps, hoses, and such like without depending on the existing power supply ● Securing water sources (including seawater as a last resort) ○ Deployment of a backup power supply and driving source for vent operation (BWR) ● Securing core cooling by the main steam relief valve through the SG (PWR)	● Releasing heat into the air by containment venting (BWR)
	Hydrogen	Before earthquake disaster			- Installed the flammable gas control system to control the density of hydrogen generated at the time of loss of coolant accident and oxygen. - Prevention of the generation of hydrogen by core cooling with ECCS, and such like - Inject nitrogen into the PCV to create an inert environment, thereby controlling the density of hydrogen and oxygen in the containment in an accident environment, below the inflammable limit.	- Did not consider the wraparound of gas between units.	- If the reactor core is damaged, hydrogen could leak from the containment.
		Proposed measures				● Release and reduction of retained hydrogen ● Prevention of wraparound from the enhanced pressure resistant vent line ● Prevention of hydrogen wraparound between units sharing the stack	● Release and reduction of retained hydrogen

<< Explanation of countermeasure situation at representative plant >>

Explanatory note in measure example column: ● → Item completed or considered from beginning due to a factor peculiar to the site
○ → Item being implemented or planned to be addressed

Table Appendix 1-2 Activity Situation for Safety Improvement at Nuclear Power Stations

To date, the following countermeasures have been taken or are being taken at each company. Of the countermeasures proposed as examples, most of those which can be implemented in short periods have been undertaken.

	Examples at PWR plant	Examples at BWR plant
Preparation of power sources If no power source can be secured due to loss of the on-site power in case of emergency, secure alternate power sources which will quickly supply the required power.	<ul style="list-style-type: none"> • Already set up power-supply vehicles and power cables. • Already prepared emergency procedures concerning power supply (fuel procurement, power connection). • Already prepared the battery charging route by the backup power. • Already taken anti-inundation measures for power sharing equipment between units. • Already taken anti-inundation measures for power supply systems. • Expected to set up generator alternative equipment for emergency and air-cooled mobile power generation devices which will stably supply power required for the state supervisory instrumentation of reactors and maintaining cooling of reactors. • Expected to lay permanently installed cables from the power source system in the station to the outside connection. • Expected to set up portable engine-driven pumps for supplying seawater in order to cool diesel generators. • Expected to enhance transmission lines. 	<ul style="list-style-type: none"> • Already set up power-supply vehicles and power cables to satisfy the power capacity for stably cooling reactors and monitoring the state of reactors, in locations unaffected by tsunami. • Already set up alternative equipment for emergency generators. • Already prepared emergency procedures concerning power supply (fuel procurement, power connection). • Already prepared the battery charging route by the backup power. • Already taken anti-inundation measures for power sharing equipment between units. • Already taken anti-inundation measures for power supply systems. • Expected to erect a coastal levee for transformers (start up transformer, house transformer). • Expected to set up feed lines from the emergency transformer on the height of an adjacent plant.
Handling of loss of heat sink Assuming that the seawater system facility or its function is lost, prepare measures for restoring a flexible cooling function.	<ul style="list-style-type: none"> • To supply water for cooling by turbine drive auxiliary feed water pumps, already set up pumps and hoses for supplying water to the condensate tank as a water source from the water tank, seawater, and such like. • Already secured portable power pumps, hoses, and such like for injecting water into the steam generator. • Already built a containment spray system by extinguishing pumps using the filtered water tank as a water source. • Already deployed washing and drying materials for seawater pump motors. • Already prepared power supply to seawater pumps by air-cooled mobile generators. • Already made arrangements for spare seawater pump motors. • Expected to make modifications such as installation of a hose tie-in nozzle on piping between the condensate tank and the raw water tank. • Expected to erect protective barriers against tsunami around the water tank and raw water tank installed at a low level. 	<ul style="list-style-type: none"> • Store fire pumps and fire hoses for supplying water in the raw water tank and seawater to the condensate storage tank in a place unaffected by tsunami. • Already deployed washing and drying materials for seawater pump motors. • Already deployed materials and equipment for injecting water into reactors, including portable power pumps and hoses. • Already secured water sources by means of taking the water from the filtered water tank, neighboring water source, and such like. • Already built an alternative containment spray system by fire trucks. • Expected to deploy portable power pumps equipped with a self-power generator. • To enhance the feedwater function to reactors, expected to install new piping enabling direct supply of water from fire trucks, and such like. • As a policy of implementing cold shutdown, expected to deploy alternative seawater pumps to secure the final cooling function in case seawater pumps, and such like become unusable due to tsunami. • Expected to have spare seawater pump motors. • Expected to deploy alternative mobile backup heat exchangers and pumps in place of permanent seawater pumps.
Countermeasures against hydrogen	<ul style="list-style-type: none"> • Already prepared the procedure for releasing hydrogen leaking from the containment vessel to the annulus by the annulus exhaust system. • Expected to install a static catalytic hydrogen recombiner package for processing hydrogen in the containment vessel. • Expected to install hydrogen sensors. 	<ul style="list-style-type: none"> • Already prepared tools and established procedures for providing openings (hole making) in the roof of the reactor building. • Expected to install hydrogen venting equipment in the top (operating floor) of the reactor building as countermeasures against retention of hydrogen. • Expected to install hydrogen sensors.
Measures of cooling the spent fuel storage pool and quickly feeding cooling water	<ul style="list-style-type: none"> • Already deployed fire pumps and fire hoses for supplying water from water sources such as fire service water and seawater. • Already secured portable power pumps, hoses, and such like for injecting water into the spent fuel pit. • Already installed ITV's for monitoring the spent fuel storage pool. • As a measure to enhance the spent fuel pit cooling function, expected to lay piping for injecting fire service water, and such like into the spent fuel pit from the outside in order to diversify makeup water methods. • Implemented power supply from the emergency bus. 	<ul style="list-style-type: none"> • Already deployed portable power pumps, hoses, and such like for injecting water into the spent fuel pool. • Already stored fire pumps and fire hoses for feeding water in the raw water tank and seawater in a place unaffected by tsunami. • Secure the power source for spent fuel water cleanup system pumps by power-supply vehicles and gas turbine generators. • Provide cooling sources by replacing seawater pump motors and washing and drying. • To enhance the feedwater function to the spent fuel storage pool, expected to lay piping enabling direct supply of water from fire trucks, and such like.
Preparation for tsunami Implement countermeasures required at the moment, based on the structure, and such like at each site.	<ul style="list-style-type: none"> • To prevent equipment important to safety (the power receiving transformer, core standby cooling system, DC power supply system, etc.) from being flooded by tsunami, already took measures to enhance the watertightness of existing doors and hatches, and building penetrations. • As a measure for early restoration after the buildings' inundation, already installed portable drain pumps. • Already deployed heavy machinery required for removing debris, such as wheel loader, bulldozer, hydraulic shovel, and crawler carrier. • Expected to erect a coastal levee as a measure to reduce the impact power of tsunami. 	<ul style="list-style-type: none"> • To prevent equipment important to safety (the power receiving transformer, core standby cooling system, DC power supply system, etc.) from being flooded by tsunami, already took measures to enhance the watertightness of existing doors and hatches, and building penetrations. • As a measure for early restoration after the buildings' inundation, already installed portable drain pumps. • Already deployed heavy machinery required for removing debris, such as wheel loader, bulldozer, hydraulic shovel, and crawler carrier. • Expected to erect a coastal levee as a measure to reduce the impact power of tsunami.

Table Appendix 1-2 Activity Situation for Safety Improvement at Nuclear Power Stations

	Examples at PWR plant	Examples at BWR plant
	<ul style="list-style-type: none"> • Expected to replace existing doors with watertight doors as a measure to prevent equipment important to safety from being flooded by tsunami. • Expected to enhance protective barriers for the seawater pump area. • Expected to erect protective barriers around the water tank installed at a low height. 	<ul style="list-style-type: none"> • Expected to replace existing doors with watertight doors as a measure to prevent equipment important to safety from being flooded. • Expected to enhance protective barriers for the seawater pump area. • Expected to change the shape of the air supply/exhaust port to the snorkel type depending on the height of inundation.
Conducting emergency checkups on devices and equipment for emergency response due to tsunami	Checked the materials and machinery and the equipment of the facility required for implementing the three response scenarios ((1) emergency power restoration by power-supply vehicles, (2) securing water feed to the steam generator, (3) securing water feed to the spent fuel pool) in case the three functions (the function of all equipment to supply AC source, function of all equipment to cool the reactor facility using seawater, function of all equipment to cool the spent fuel storage pool) are lost. Expected to check equipment, which can be inspected only when starting the plant and at the time of periodic inspection, in the future.	Checked the materials and equipment required for implementing the three response scenarios ((1) emergency power restoration by power-supply vehicles, (2) securing water injection to the reactor, (3) securing make-up water to the spent fuel storage pool) in case the three functions (the function of all equipment to supply AC source, function of all equipment to cool the reactor facility using seawater, function of all equipment to cool the spent fuel storage pool, and such like) are lost.
Implementation of inspection and training of the emergency response plan, assuming station blackout, loss of the seawater cooling function, and loss of the cooling function for the spent fuel storage pool	<ul style="list-style-type: none"> • Assuming loss of the three functions, conducted training for (1) emergency power restoration by power-supply vehicles, (2) securing water feed to the steam generator, and (3) securing water feed to the spent fuel pool. • For the emergency response plan, drawn up the “Response for safety of the reactor facility in case of loss of power supply functions” stipulating the organization, duty allocation, personnel assignment, procedures, training, materials and equipment, and such like, revised related operational procedures, and conducted training for them. 	Established company rules stipulating the organization, duty allocation, personnel assignment, procedures, training, and materials and equipment as the emergency response plan for implementing the three response scenarios ((1) emergency power restoration by power-supply vehicles, (2) securing water injection to the reactor, (3) securing make-up water to the spent fuel storage pool). In drawing up these company rules, conducted training and picked up those which need to be improved for feedback.
Emergency response training	<ul style="list-style-type: none"> • Already conducted training for distribution of electric energy by power-supply vehicles, training for emergency water delivery by fire trucks, and such like (Conducted continuously) • Already conducted field training by simulating station blackout. (Conducted continuously) • Already conducted active training wearing protectors, and such like (Conducted continuously) 	<ul style="list-style-type: none"> • Already conducted training for distribution of electric energy by power-supply vehicles, training for emergency water delivery by fire trucks, and such like (Conducted continuously) • Already conducted field training by simulating station blackout. (Conducted continuously) • Already conducted active training wearing protectors. (Conducted continuously) • Already conducted training coordinating with actual working by using a simulator for initial response. (Conducted continuously) • Conduct work training for providing openings (hole making) in the roof of the reactor building in order to release hydrogen. (Continue to conduct training) • Emergency response personnel already obtained the qualification of operating heavy machinery.

Appendix 2 Comments from members of the technical analysis subcommittee, Atomic Energy Society and responses

In compiling the report at this time, we requested members of the technical analysis subcommittee, the “nuclear safety” investigation committee of Atomic Energy Society of Japan to see if there are any factors omitted and any unreasonable points concerning countermeasures.

We received comments as shown in the table below and reviewed the report based on them.

We also show responses from the Examination Committee to the comments received.

Academic Meeting's Comment (Including reasons)	Examination Committee's Response
<p>We think that the biggest lesson we learned from the accident this time was the lack of defense in depth for a sequence of events caused by massive tidal waves. Its specific contents are as described throughout the report. However, this report should play an important role in helping people understand the relation between the cause of this accident and the emergency countermeasures (described in "Introduction"). But, isn't there any description from that standpoint? It is also desirable to know how many examples of a large number of countermeasures described in the report are covered by the emergency countermeasures. If it is not possible to do so this time, wouldn't it be better to evaluate in some kind of form and describe them later?</p>	<p>Emergency countermeasures implemented by each company are summarized and described in Appendix 1.</p>
<p>The biggest lesson we learned from the accident this time was the problem of AM. Specifically, it is how accurately you will grasp the reactor core status at the time of an accident. The press release by TEPCO on the day is shown in Separate Attached Table 1. It is apparent that the reactor core status grasped was significantly different from the analysis result obtained later. The lessons learned from this fact and countermeasures for it should be presented.</p>	<p>For Unit 1, this stemmed from the fact that TEPCO judged that the reactor core was functioning by observing steam from the IC vent pipe and the reactor water level was maintained according to the instrument indication. While it is important to ensure the reliability of instruments, the lessons learned and countermeasures are stated in "4.10.3 Measurement at the time of an accident."</p>
<p>Simply "tsunami"</p>	<p>In effect, various scales of tsunami waves repeatedly surge accompanying an earthquake. We classified waves having affected the site as the first wave and second wave and expressed them as "otsunami" (massive tidal waves).</p>
<p>It is said that this report is a study limited to about the first five days after this accident occurred. But, it seems unclear how much the lessons were learned "deductively" and "deeply." For example, this report simply derived lessons but did not derive lessons deductively. Supposing this to be a future issue, it is desirable to clearly state this fact as a prerequisite.</p>	<p>RCA is not in a state where a hearing investigation is possible and so we have not done it. We have described that fact. The concept is gathered together and described in Chapter 4.</p>
<p>For instance, the measurement of the reactor liquid level is divided into the A system and B system. There are multiple levels of water level indicators for each system and multiple water level indicators of the same level are also installed. They are monitored or recorded by the safety protection system, the monitoring invariant of the control room, the monitoring panel (pen recorder), and such like. It is desirable to add descriptions about what issued signals after the arrival of tsunami and whether they could be judged to be reliable.</p>	<p>After the power for instruments was lost, portable batteries were connected to the instrument board, and such like in the main control room, and indicated values were checked. Details are unknown from the data published by TEPCO. We additionally stated that the value indicated when the reactor water level of Unit 1 was checked might not have been accurate. We also added a discussion about the reliability of instruments in "4.10.3 Measurement at the time of an accident."</p>

Separate Attached 1 Comparison of grasping situation of reactor core state on the day of accident occurrence and its subsequent analysis results

Date and Hour	Press Release by TEPCO (http://www.tepco.co.jp/nu/f1-np/press_f1/2010/2010-j.html)	Recognition for cooling of each unit on left column			Cooling of each unit according to the government report for the IAEA cabinet board meeting		
		Unit 1	Unit 2	Unit 3	Unit 1	Unit 2	Unit 3
March 11, 2011, around 17:00	After that, we could not confirm the flow rate of injection water for the emergency core cooling devices of Units 1 and 2. Then, we judged that a specific event based on the provision in Clause 1, Article 15 of the Special Law of Emergency Preparedness for Nuclear Disaster had occurred at 16:36, as a precautionary measure. According to the same clause, we notified the Minister of Economy, Trade and Industry, the governor of Fukushima Prefecture, the mayor of Okuma Town, the mayor of Futaba Town, and the related administrative agencies of the event. After that, since the water level monitoring was recovered for Unit 1, we determined that the Station had recovered from the event specified under Article 15 lifted Clause 1, Article 15 of the Special Law of Emergency Preparedness for Nuclear Disaster. But, we again determined that the Station had experienced a specific event based on the provision in Clause 1, Article 15 of the Special Law of Emergency Preparedness for Nuclear Disaster for Unit 1 at 17:07.	Unknown ↓ Unknown	Unknown	No description	No cooling	Being cooled	Being cooled
March 11, 2011, 19:00	Steam in the reactor is being cooled by the emergency condenser at Unit 1 and water is being injected into the reactors by the reactor core isolation cooling system at Units 2 and 3. We are securing the reactor water levels without any safety hazard at Units 4, 5 and 6.	Being cooled	Being cooled	Being cooled	No cooling	Being cooled	Being cooled
March 11, 2011, 21:00	The reactor of Unit 1 has been shut down and reactor steam is being cooled by the emergency condenser. At this time, we think there is no leakage of coolant in the reactor containment vessel. The reactor of Unit 2 has been shut down and cooling water has been injected into the reactor by the reactor core isolation cooling system. But, the operating condition is unknown at present and therefore, we cannot confirm the reactor water level. The reactor of Unit 3 has been shut down and cooling water is being injected into the reactor by the reactor core isolation cooling system. At this time, we think there is no leakage of coolant in the reactor containment vessel.	Being cooled	Unknown	Being cooled	No cooling	Being cooled	Being cooled
March 11, 2011, 0:00	Unit 1 (Being shut down) • The reactor has been shut down and reactor steam is being cooled by the emergency condenser. • At the present moment, radioactive material may be released due to a drop in the water level in the reactor. The government has instructed local residents living within a radius of 3 km from the power station to evacuate, and those living within a radius of over 3 km to 10 km to stay indoors. Unit 2 (Being shut down) • The reactor has been shut down and water has been injected into the reactor by the reactor core isolation cooling system. Although the operating condition is unknown at present, we could confirm the reactor water level by using a temporary power source and the water level is stable. • At the present moment, radioactive material may be released due to a drop in the water level in the reactor. The government has instructed local residents living within a radius of 3 km from the power station to evacuate, and those living within a radius of over 3 km to 10 km to stay indoors. Unit 3 (Being shut down) • The reactor has been shut down and water is being injected into the reactor by the reactor core isolation cooling system. • At this time, we think there is no leakage of coolant in the reactor containment vessel.	Being cooled	Unknown	Being cooled	No cooling	Being cooled	Being cooled

Academic Meeting's Comment (including reasons)	Examination Committee's Response
One unit is a dedicated DG for improving the reliability of the high-pressure core injection system and has a smaller load capacity as compared with the other two units. It is not designed to drive the RHR system (main pump, seawater pump, and such like) and therefore, we think that it should not be treated in the same way as them.	One unit is the DG for HPCS as you pointed out. However, in explaining the progress of accident events, we judged that there was no particular problem even if we included it in the functional aspect as an emergency DG.
Is it possible to determine whether the DG is "sound" only by observing the fact that it is operated? (What is the definition of "integrity"?)	There is a list of devices which functioned in the material of TEPCO. The list showed that all the devices functioned. Since no abnormal conditions were described before the tsunami arrived and there was no description saying that parameters were unanticipated, either, we judged that all the devices were sound.
What was the situation with regards to the D/D pumps of Unit 2?	They were not operated. The details are not known.
Water is fed by MUWC for Units 5 and 6. Couldn't MUWC pumps be used at any of the units? Was that at part of the plant?	They could not be used at Units 1 through 4. We will add a description of that fact. The extent of damage is unknown (whether simply flooding or burned), they say.
Did a loss of function occur at all of Units 1 through 6?	They could not be used at Units 1 through 4. We will add a description of that fact. The extent of damage is unknown (whether simply flooding or burned), they say.
Concerning the loss of function, is it correct to say that seawater entered the reactor building, which is expected to be the fifth multiple barrier. In other words, can we judge that the fifth multiple barrier is not functioning at the lower part of the reactor building? Unable to judge from this table; how did the seawater enter the reactor buildings for Units 1 through 5?	For Unit 6, while some areas were flooded in the R/B, the DG installed area and the DG body were not inundated. But, the loss of function occurred since the DG seawater pump failed to function because of the tsunami and the power panel (installed in the T/B) was inundated. Investigation could not be performed in the R/B's for Units 1 through 4 and consequently, whether or not there was inundation due to tsunami is unknown. In the R/B for Unit 5, flooding was confirmed in the first basement; it is suspected that the flooding occurred not due to the tsunami but due to the entry of groundwater containing seawater.
Wasn't the NSIV closed due to a low-voltage signal of the emergency AC bus? According to the description of the "protection system power source," it is judged that the DC power supply, which is the support system of the protection system, was lost. For designs for occurrence of abnormalities, you should properly write that loss of external power supply (not station blackout) will result in closing of the MSIV. Same for the descriptions of Units 2 and 3. Since the description (3) a. on pages 3 to 25 is considered more accurate, it is desirable to standardize them. If possible, it is advisable to additionally write that the MSIV closing sequence is different from that of other BWR's (2F, Tokai Daini, Onagawa).	TEPCO's report says that upon transmission of the "reactor protection system blackout" signal, the electromagnetic valve will be deenergized causing the main steam isolation valve (MSIV) to be closed. In the illustration for the MSIV interlock, there is no other information concerning the power source. In the event progress explanation, it is stated that the MSIV was automatically closed as the power of the emergency bus was lost. For its flow, it is deemed that loss of external power supply, loss of emergency bus power supply, reactor protection system blackout, and closing of the MSIV take place in this order.
It is difficult for us to know what the facts were. Some of the events observed at the time of the accident contained improper indications. To compile the events this time, not immediately after the accident, misinformation should be clarified by adding notes to inaccurate information. Information leading directly to a meltdown is particularly important when reviewing future countermeasures for AM. Therefore, such information should be described very carefully. For example, pages 2 to 21 "At 21:19 on March 11, it turned out that the reactor water level (active fuel) was the instrument indication of +200 mm from TAF. Pages 2 to 27 "21:19 Reactor water level found, TAF + 200 mm"	The instrument's error indication suspected at the present moment is the reactor water level of Unit 1. We will add a description to the effect that the indication is doubtful. (The indication is suspected of being improper because it was not consistent with TEPCO's analysis results of the reactor core status and there was a difference as a result of calibrating the water level indicator.)
Was the reason for the closure known?	The operation only was described in TEPCO's report so that no reason has been explained. After that, open operation was performed again at 21:30 on the same day. The additional report (second report) submitted by the government to the IAEA gave a description to the effect that "close operation was performed because they no longer were able to confirm the generation of steam immediately after that."
Was this the effect of "manually opened the valves of CS, and such like" (described on pages 2 to 20)? Or, should we judge that reduction in pressure occurred because of the fact that RPV and CV were already leaking as a white haze was observed when the dual-structured door was opened?	No details are known. The valve open operation of CS (reactor core spray system) is performed for a water injection line lineup for MUWC and FP of AM. It is difficult to identify the cause at the present moment because the effect of IC is unknown, and such like. (RPV was damaged, assuming that IC was inoperative, about 15 hours after the occurrence of the earthquake according to TEPCO's analysis result of the reactor core status, which means it was not yet damaged at 02:45 on March 12.)
It is desirable to add a description of the effectiveness of 80,000L. SP: 1750m ³ (Reference-2)	According to TEPCO's analysis result of the reactor core status, the reactor core began to be damaged four hours after the earthquake and RPV was damaged 15 hours after the earthquake, assuming that IC was inoperative. It is suspected that water was injected after the reactor core was damaged because injection of water began 15 hours after the earthquake. Its effectiveness is unknown at the present moment.
Isn't it impossible to perform containment spraying in an SBO state?	It is said that D/W spraying was performed with the D/D extinguishing pump using the AM line. We will add a description of that fact.
It is also suspected that falling debris at the time of the hydrogen explosion caused the water level of the spent fuel pool to drop significantly. Is it appropriate to conclude that the water level was maintained only by judging from the description of the amount of water injected?	In the evaluation of TEPCO's report, the amount of evaporation was calculated from fuel energy deposition to indicate that the water level was maintained even if sloshing is taken into consideration.

Academic Meeting's Comment (including reasons)	Examination Committee's Response
It is suspected that a particularly large amount of radioactive material was released on March 15 and March 16. Isn't it necessary to conduct analysis while considering which event led to the release of radioactive material?	Such release can only be presumed at present time and therefore, its analysis was passed on. However, we think that W/W venting will not affect the environment much.
It is better to clarify criteria for determining the success or failure of PCV venting. PCV venting is regarded as "success" at Unit 3. However, hydrogen may have leaked into the building due to leakage from the containment, and the cause is suspected of being excessive temperature or excessive pressure.	We deemed a case to be a success where it is judged that the pressure dropped due to the actuation of the rupture disk according to the system configuration.
It is better to clarify criteria for determining the success or failure of water injection. For example, is it treated as success even if the flow rate of water injection is very low?	Although it is a matter of degree, we basically deem a case to be a "success" if water is injected even if the flow rate is low.
It is better to clarify criteria for determining the success or failure of depressurization. For example, for Unit 2, wasn't the reactor core suspected of being damaged before depressurization was carried out? Isn't this regarded as "failure to depressurize" from the aspect of incident response even if depressurization is successful?	Although a factor of time required for depressurization should be taken into consideration, we made a judgment here only depending on whether depressurization was carried out or not. Timing should be considered together with water injection and therefore, we decided to pick up the factor of time on that side.
Isn't it also necessary to describe the failure of the DC power supply? (It should have a meaning different from restoration of AC power supply in terms of safety.)	We described, it judging loss of AC power supply to be a major factor in the progress of the accident. We also extracted issues for DC power supply and described countermeasures.
It seems that loss of DC power supply, including the measurement power supply, also has a considerable impact on the progress of the accident.	We described, it judging loss of AC power supply to be a major factor in the progress of the accident. We also extracted issues for DC power supply and described countermeasures.
Shouldn't loss of DC power supply for instrumentation and control be regarded as the main cause? It is described in Tables 3.3-1 – 3.	Although loss of DC power supply is also a relatively large issue, we described the result of narrowing down the major factors. We extracted DC power supply as an issue and also described countermeasures.
Is "early power recovery" here assumed to be only one by power-supply vehicles? Aren't factors, which are directly related to "deployment" of power-supply vehicles, only damage to roads, traffic jams, access to roads on the premises, and communication means? Isn't it better to list other factors as at the same level as for difficulty of deployment of power-supply vehicles, because they become obstacles for early external power source recovery?	Since the external power source function is lost, emergency DG function is lost and furthermore, interchange between units is not available, only the one left is power supply by power-supply vehicles. Consequently, we described factors for power-supply vehicles. While the factors you pointed out are common obstacles during recovery operation, it is necessary to describe them somewhere and we listed them as subjects here.
An additional description to show whether the fuel storage tank and supply piping were sound.	There is no such description and its details are unknown.
If early external power source recovery means utilizing power-supply vehicles, shouldn't no deployment of power-supply vehicles at the site be listed as an issue?	We positioned deployment of power-supply vehicles as a countermeasure for the issue of the fact that "we suffered a wreck because no power source was available."
On page 3, it says that depressurization of the reactor was successful. It also says that PCV venting was successful. These descriptions are inconsistent.	Although the objective was finally achieved, there is a discrepancy because it took time and such operations were impossible in the initial stage. We will correct it.
Is it possible to assert that HPCI became inoperable because of exhaustion of DC power supply?	TEPCO's report states "due to exhaustion of battery power" and we followed it.
We understand that rapid depressurization by the SR valve under SBO is performed when water injection operated by the DC power supply such as of RCIC fails to operate. Considering a state where DC power supply has already been exhausted, isn't it necessary to figure out countermeasures?	Depressurization is necessary for alternative water injection. Therefore, we gathered together the problems that occurred this time and described it as an issue.
Were spare seawater pumps prepared for all the units?	Not for all the units, they were spare pumps that were kept for replacement during periodic inspection. Since no cranes could be used for recovery, makeshift pumps were used for Units 5 and 6.
Wraparound for the reactor building from the venting line has not been analyzed but it is only described as an issue. Isn't it better to describe a reason for having listed the wraparound from the venting line as a reason? As indicated on pages 3 to 14 and pages 3 to 27, leakage from the CV is also regarded as a passage route to the reactor building. Shouldn't this also be listed as an issue?	We will consider an additional description. It has been conjectured from the radiation dose of the filter and piping. The issue of direct leakage from the containment is picked up on the confinement function side and assumed to be sealing performance of the penetration and flange. For sealing performance of the penetration, it is not realistic to require sealing performance for hydrogen exceeding the designed condition. We decided to address the issue on condition that leakage could occur without drawing up special countermeasures.
The description is about a situation and analysis of its cause rather than an "issue." It is easier to understand if the matter was described in the progress of the accident in Chapter 2 than described in Chapter 3.	While Chapter 2 gathers together the declared facts without using subjective views and conjectures as much as possible, Chapter 3 conducts analysis based on such facts.
What grounds are there to say that the rupture disk did not operate under a condition where it should have operated?	For the rupture disk's non-operation listed as an issue here, the fact that the rupture disk did not operate because the pressure was low at Unit 2 was described as an issue. We will correct it.
Isn't it necessary to list collapse of the steel tower as a subject of future investigation?	For the steel tower, each company evaluates its earthquake-resistance according to the instructions of the government and that fact is described in the section on countermeasures. Furthermore, each company has already begun to review redundancy of the transmission system for external power source. Therefore, we did not describe this matter as an issue but we will list it as an issue.
At Unit 6, the function of RHR must have been lost temporarily. (Wasn't the recovery of the RHR function successful?)	We will correct it.
The tsunami entered the premises at Fukushima Daini.	We will correct it.
It is first necessary to prevent tsunami from entering the premises from the standpoint of defense in depth. Therefore, a breakwater will be necessary. Similarly, measures to prevent inundation will also be required for major components.	Considering that there may be a plant where it is not necessary to protect the entire premises by a breakwater, we made a description seeking protection for necessary places.
How about gathering together issues in a form catching up with defense in depth (or progress of events)?	We will include the concept of defense in depth in the countermeasures system. We will gather together issues in line with the progress of events as much as possible.

Academic Meeting's Comment (including reasons)	Examination Committee's Response
Issues and countermeasures are mixed in the five items in the table.	For issues, we consciously described what the problems were and made consideration to avoid taking in advance recommendations of countermeasures to be discussed in Chapter 4. However, we included descriptions of the countermeasures system to some extent for accurate communication.
Pertaining to the review of pressure-resisting design of the containment including CV venting, the pressure-resisting enhancement of the seal portion may not be effective. (Was there any problem with sealing performance at about the designed pressure in the accident this time?)	Since hydrogen may have leaked directly from the containment, the enhancement of sealing is listed as an issue. However, it is technically difficult to suppress the leakage of hydrogen, assuming an accident exceeding the design conditions, as a countermeasure, we decided to recommend taking countermeasures on condition that hydrogen could leak.
"Reliability of power source for tsunami" is an abstract expression, and we do not understand its real meaning. Is it unnecessary to list the diversity of power sources as an issue?	We will correct it. Considering that securing diversity is included in the countermeasures system, we do not mention it here.
How about gathering together issues in a form catching up with defense in depth (or progress of events)?	We will include the concept of defense in depth in the countermeasures system. We will gather together issues in line with the progress of events as much as possible.
How about gathering together issues in a form catching up with defense in depth (or progress of events)?	We will include the concept of defense in depth in the countermeasures system. We will gather together issues in line with the progress of events as much as possible.
Descriptions are made in terms of defense in depth in 4.6.1 through 4.6.3. Isn't it possible to additionally describe countermeasures in case of inundation in 4.6.4? Examples include improvement of the centralized arrangement of multiplexed systems and installation of partitions.	Countermeasures considering entry of water into buildings are compiled in each of the items such as power source and heat sink. (Example: Described "making allocated places watertight as necessary," and such like)
It is also necessary to add mention of fire as caused by tsunami. Not recognizing it when compiling the lessons learned of the Nuclear Society, we spoke to experts on tsunami and found out that fire occurred at a significant frequency during the tsunami resulting in a secondary disaster. At a power station, fuel storage tanks or cars may be swept away and leaking fuel may ignite. Therefore, we think it is necessary to take such fire into consideration.	Since countermeasures for "occurrence of fire due to tsunami" are not directly required from accident analysis this time, we will cover this matter in Appendix 2 "Subjects of future investigation."
For failure to consider linking to multiple areas, isn't it necessary to conduct analysis in more detail (deeply) and draw out more universal lessons without limiting them to tsunamis and earthquake ground motions?	It is also said at the Central Disaster Prevention Council of the government that "the earthquake this time extensively exceeded the expected level of disaster that could occur." Therefore, we would like to extensively study the lessons learned through analysis and evaluation by academic meetings for earthquake and tsunami. Note that the necessity of preparation for the entire natural hazard is compiled as lessons in 4.1.
The cause analysis of "early power source recovery" on pages 3 to 5 is not consistent with the description here.	Of the early power source recovery, the issues relating to the factors restricting operations are also common to other incident response. Therefore, we compiled them in "4.10 Preparedness for emergency." We will additionally state that fact.
Isn't it necessary to establish operating procedures in view of the operating range with RCIC, describing in which stage depressurization by the SR valve is carried out? Isn't it also necessary to study the amount of water injected to prevent damage to the reactor core due to a drop in water level by depressurization boiling during rapid depressurization?	For the operation using regular equipment such as the water makeup system, we have already reflected the appropriate depressurization timing in the procedures depending on the available water injection means, reactor water level, and other plant parameter indications. From this time, we will reflect equipment and means, such as fire trucks, added to the emergency safety measures in the procedures.
Also relating to the assumption of the maximum pressure in PCV and the countermeasure by PCV venting, is "increasing the injection pump pressure" (injection possible at about 10 atm (abs)) unnecessary?	As a result of reviewing the effectiveness of alternative water injection using high-pressure injection pumps, we mentioned the deployment of movable power pumps as a countermeasure and let each power company determine their specifications.
More widely interpreting the lesson learned from failure to use the seawater system, isn't it necessary to study multiplying the water intake route by considering damage to the intake, and such like?	There is no information on blocking of or damage to the intake at the present moment. We would like to study it if there will be a fact seeking its necessity in the future.
After the reactor core is damaged, containment venting may raise the surrounding air dose, making it difficult to take subsequent action for items including other units. For this reason, it is necessary to study countermeasures for further reducing the amount of radioactive materials released by containment venting.	At the present time, we think that there was no situation in which the dose rose significantly by PCV venting and the effectiveness of W/W venting is unclear. Therefore, we decided to treat filter venting as a subject of future investigation.
Necessity of filter venting: After measures to prepare a power source and such like, and measures to secure the depressurization and water injection functions are taken, recovery of the cooling (RHRS) function of the S/C is the key to this matter. To prepare for a case where recovery cannot be readily achieved due to failure of function for mechanical/electrical reasons and heat removal fails due to lack of diversity by natural circulation and such like (as was the case this time), we agree with the last measure of releasing decay heat into the air by containment venting as an alternative solution. In fact, this was the only measure that could be taken this time. We thought that only the measure to be taken was to depressurize and repeat (alternative) injecting water and removing heat by evaporation or continue it if it could not be repeated before the reactor core was exposed until the function of the RHRS such as the seawater pump was recovered. In this way, in a case where containment venting is required to provide the functions of preventing the occurrence and expansion of damage to the reactor core, doesn't it become necessary to frequently perform venting as soon as the S/C loses the pressure suppression function as the conventional meaning of venting, i.e., protection of the containment and effect mitigation of the accident is expanded? For this reason, we think the concept of filtered venting will become more and more important.	If the state in the containment exceeds the designed conditions with the decay heat removal function lost (before the reactor core is damaged), it will be necessary to perform a venting operation by which decay heat is released in a form of steam as alternative heat removal means. If the decay heat removal function cannot be recovered for long hours, water injection into the reactor and steam discharge (so-called feed and bleed) will be continued as you pointed out. However, in this state, FP is hardly contained in discharged steam and therefore, this matter is not related to filter venting. On the other hand, if a venting operation is performed after the reactor core is damaged, the conventional procedure requires scrubbing through a suppression pool to be conducted as much as possible. But, in the accident this time, the emission of radiation could not be sufficiently suppressed because the integrity of the containment could not be maintained due to failure to perform sufficient alternative water injection. Therefore, we think that reliability improvement of the cooling means and securing integrity of the containment should be primarily given top priority. However, since it is important to thoroughly avoid environmental contamination, we decided to treat filter venting as a subject of future investigation.

Academic Meeting's Comment (including reasons)	Examination Committee's Response
<p>We think that the relation with time that can be secured before prevention of damage to the reactor core by built-in equipment (including additionally installed items after the accident this time) is important. How about adding a further review in two ways (time that can be secured for resistance characteristics on the equipment side and time required for emergency response)?</p>	<p>We would like to judge its necessity by reviewing the results of stress tests being conducted at present.</p>
<p>Although the descriptions in this section may not be appropriate, we would also like you to study the following working conditions.</p> <ul style="list-style-type: none"> • Temporary lighting • Temporary air conditioning • Temporary drainage equipment 	<p>We will add a description of arrangement of materials and equipment relating the items you pointed out, in "4.10.9 Preparation for disaster countermeasures."</p>
<p>Isn't it necessary for us, including the local government bodies and the state, to make clear who is responsible for judgment as well as the timing of judgment?</p>	<p>We decided to treat the items that need to be adjusted with the state and local government bodies as subjects of future investigation.</p>
<p>Enhancement of the monitoring posts including the transmission system and power source system was also pointed out when the Kashiwazaki Kariwa Nuclear Power Station was damaged by the Chuetsu Offshore Earthquake. Isn't it necessary to review why this lesson could not be understood (or understood but could not be addressed)?</p>	<p>This is because the large factor in the accident this time, which is different from the case of Kashiwazaki, is tsunami and furthermore, the accident spread to loss of power source, loss of the transmission system, loss of the communication function, and such like. We described factors in the section on countermeasures.</p>
<p>Isn't the measure for reducing the number of storage fuel pieces in the spent fuel pool (example: utilization of the dry cask) subject to review?</p>	<p>This means how to deal with decay heat depending on the number of fuel pieces stored at that point and time after the fuel is taken out. We described this matter judging that basically maintaining the water level is sufficient.</p>
<p>We understand that prevention of occurrence and expansion and effect mitigation of an accident in the table mean prevention of occurrence and expansion and effect mitigation of an accident against events beyond the assumed designed standard events. In this case, the question is whether this matter has been further studied in terms of BDBE requiring equipment installation or whether the one previously regarded as BDBE will be changed to DBE because the previously assumed design standard against tsunami was not strict enough. Isn't it better to make a proposal showing how this matter should be?</p> <p>Countermeasure examples for the present situation are outside the third layer called in defense in depth or the fourth layer. It may be described that they may be seen as an extension of defense in depth for DBE referring to prevention of occurrence and expansion and effect mitigation for BDBE.</p> <p>We agree with Mr. Morokuzu's statement that countermeasures for safety design and SA countermeasures should be described by clearly separating them.</p>	<p>We added the fact that we gathered together this matter based on the concept of defense in depth in Table 4.12-1 summarizing countermeasures and gathered together that concept as the conventional design base, accident management and severe accident countermeasures to be added this time in "4.12 Summary of countermeasures." However, whether severe accident countermeasures will be regarded as DBE or not is limited to a description to the extent that temporary installation is acceptable.</p>
<p>Descriptions of respective layers of safety design and SA countermeasures should be clearly separated.</p> <p>The most important thing in the design concept of defense in depth is to provide complete accident countermeasures for each layer. Defense "in depth" comes to have a meaning by independently taking accident countermeasures in the first layer "prevention of occurrence," second layer "suppression of expansion," and third layer "effect mitigation." A countermeasure, which cannot be realized unless multiple layers are combined, cannot be said to be "in depth." Countermeasures for safety design and SA countermeasures should be described by clearly separating them.</p> <p>The horizontal axes in Table 4.12-1 are the first layer, second layer and third layer for the present safety design. How about adding "SA countermeasures for the fourth layer" as a horizontal axis and describing SA countermeasures there?</p>	<p>We added the fact that we gathered together this matter based on the concept of defense in depth in Table 4.12-1 summarizing countermeasures and gathered together that concept as the conventional design base, accident management and severe accident countermeasures to be added this time in "4.12 Summary of countermeasures."</p>

Appendix 3 Comparison of the Development of the Accident at the Fukushima Daiichi Nuclear Power Station and at Other Stations (Detailed Version)

Section 3.6 “Comparison of course of accidents at Fukushima Daiichi Nuclear Power Station with other Stations” summarizes a comparison of Fukushima Daiichi Units 1 to 3 and Fukushima Daini, Onagawa and Tokai Daini. Details for each Station are provided below.

Summary of the events at the Fukushima Daini Nuclear Power Station

Although the functionality of the seawater cooling systems was lost at the Fukushima Daini Units 1, 2 and 4 due to the tsunami, RCIC operation ensured the capability of reactor core cooling. Subsequently, a make-up water system was used to provide an alternative means for injecting water into the nuclear reactors and containment vessels. As a result, cooling of the reactor cores and SFP fuel was maintained for roughly three days without venting the containment vessels. Meanwhile, the workers restored the seawater system, and finally restored the residual heat removal functionality when the RHR equipment began working again. The workers shifted to a cold shutdown. Because they secured the power supply, it was possible to secure extra time by utilizing safety equipment for severe accidents even without the functionality of the seawater system, and it was possible to shift the Station into a safe state.

At Unit 3, reactor core cooling was ensured with RCIC operation, followed by injection of water from an alternate source. The workers used the B system to secure the residual heat removal (RHR) function.

The course of events at Fukushima Daini is shown in an event tree in Appendix 3-1.

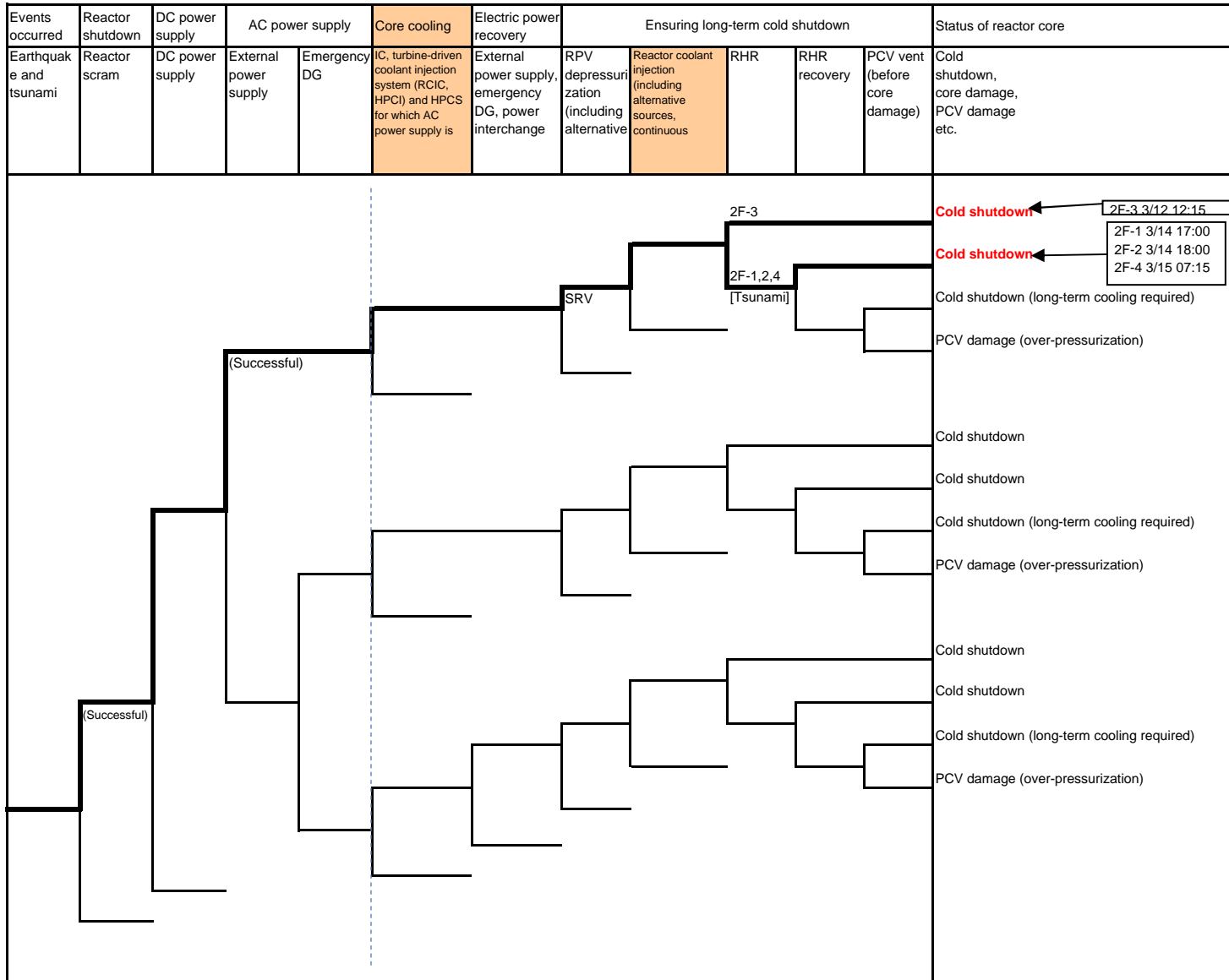

Figure Appendix 3-1 Fukushima Daini Nuclear Power Station disaster identification events tree

(1) Effects of the earthquake and tsunami

a. Effects of the earthquake

The maximum acceleration rate obtained in the reactor building base mat (the bottommost underground floor) due to the earthquake was confirmed to be less than the maximum response acceleration for basic earthquake ground motion S_s, formulated to include the revised guidelines for seismic design review.

Also, although the response spectrum of the seismological record exceeded the response spectrum for basic earthquake ground motion S_s during a portion of the periodic band, the Station confirmed as generally being equivalent or lower.

The Station used the seismological record to analyze the seismological response of the critical safety equipment, and it is believed that the Station secured the safety functions during and subsequent to the earthquake.

b. Effects of the tsunami

A study on the tsunami caused by the Great East Japan Earthquake that struck on March 11 showed that the inundation height and inundation areas on the ocean side and primary reactor building areas were as follows (ground movement due to the earthquake is not included):

1) Inundation height

(a) Ocean side area (site O.P. +4 m)

- Approximately +7 m* (inundation depth, approximately 3 m)

* There were local levels that were higher such as on the south side of the Unit 1 heat exchanger building.

(b) Primary reactor building area (site O.P. +12 m)

- Approximately +12 to 14.5 m* (inundation depth, approximately 2.5 meters or lower)

* Locally, O.P. + approximately 15 to 16 m from the south side of the Unit 1 building to the base-isolation structure
(Inundation depth: approximately 3 to 4 m)

2) Inundation areas

(a) Although the entire ocean side area was affected, flooding was not found in the primary building area beyond the slope of the ocean side area

(b) Inundation concentrated on the roads from the southeast side of the primary building area to the base-isolation structure, and the building environments of Units 1 and 2 as well as the south side of the building of Unit 3 were inundated (there was no flooding near the building of Unit 4)

(2) Unit 1

a. Station behavior upon occurrence of the earthquake

During the constant operation at the rated thermal output, Unit 1 automatically shut down at 14:48 on March 11, 2011 due to the “high seismic acceleration trip” caused by the earthquake occurred at 14:46 on the same day (the epicenter was Sanriku-oki). The maximum acceleration observed at the power

station was 305 gal at the second floor of the basement of the Unit 1 reactor building. All reactors automatically shut down because their protection system activated properly as designed. Immediately after the automatic shutdown of the reactor, the following facts were confirmed: the reactor was subcritical; all control rods were fully inserted; and all the facilities required for cold shutdown of the reactor and cooling of SFP were in normal and stable conditions.

However, such facilities required for cold shutdown of the reactor and cooling of SFP became inundated and disabled by the tsunami which occurred after the earthquake (the first wave of the tsunami was visually confirmed at 15:22 on the same day, March 11).

In addition, due to loss of the reactor's heat removal function, S/C could not be cooled down. Therefore, the S/C water temperature gradually increased to over 100°C.

Subsequently, in order to partially restore the facilities required for cold shutdown of the reactor and cooling of SFP to their usable states, the workers inspected and repaired the flooded facilities, and power was supplied from a temporary power supply. After recovering the heat removal function of the reactor, the workers cooled the S/C water to a temperature lower than 100°C. From then until 17:00 on March 14, the reactor's water temperature was maintained at a temperature lower than 100°C (i.e., in a cold shutdown state) through the RHR1 system, while at the same time the SFP system was continuously cooling down. Currently, the Station is in a stable condition.

b. State of the “Stopping” function

Upon the occurrence of the “high seismic acceleration trip” at 14:48 caused by the earthquake (at the second floor of the basement of the reactor building, set point for operation in a vertical direction: 100 gal), all control rods were fully inserted immediately. The reactor automatically shut down as designed, and the reactor became subcritical at 15:00 on the same day.

At 05:58 on March 12, the alarm went off, detecting the abnormality in the Position Indicate Probe (hereafter called “PIP”) of the control rod 10-51. Although the alarm condition was cleared once at 10:30 on the same day, this situation was repeated several times. There are two ways to indicate the control rod position. One is to indicate the “full insertion” state. The other is to indicate the position of the rod itself. When the alarm went off, while the PIP's “full insertion” indicator lamp was not on, the position indicator lamp was indicating that the control rods were fully inserted. When the alarm condition was cleared, the “full insertion” indicator lamp was on.

Furthermore, when the alarm went off, no significant change was observed in the indication of the Start-up Range Neutron Monitor (hereafter called “SRNM”) and the reactor's subcritical state remained unchanged. Although the alarm condition was cleared at 12:02 on March 13, the control rods were isolated (bulb-out) at 15:18 on the same day to avoid activation. Since then, no significant change has been observed in the SRNM indication and the reactor's subcritical state has been maintained.

c. State of the “Cooling” function

Immediately after the automatic shutdown of the reactor, the reactor output rapidly declined, thus decreasing the void in the reactor core. As a result, the

reactor water level dropped to the “reactor water level low (L-3).” Subsequently, the reactor water level returned to the automatic-initiation water levels^{*2} of the ECCS pumps^{*1} and the RCIC system without any fall due to the water supply from the reactor feed water system.

*1 ECCS pumps (common among Units 1 to 4 of this Power Station)

- HPCS pump
- Low Pressure Core Spray (hereafter called “LPCS”) pump
- RHR pumps (A, B, C) Low Pressure Coolant Injection (hereafter called “LPCI”) mode

*2 Automatic-initiation water levels (common among Units 1 to 4 of this Power Station)

- HPCS and RCIC.....L-2
- LPCS and RHR (LPCI)L-1

MSIV was completely closed manually at 15:36 on March 11 and the reactor pressure was controlled through SRV in preparation for the following situations: the circulating water pump (hereafter called “CWP”) may shut down due to a tsunami, and may thus cause malfunction of the main steam condenser; and the turbine gland sealing steam may become lost due to the auxiliary boiler shutdown caused by earthquakes. Furthermore, upon full closure of the MSIV, the RCIC system was manually activated at 15:36 on the same day in order to pour water onto the reactor. After the RCIC system automatically shut down at 15:40 on the same day due to the “reactor water level high (L-8)” the reactor water level was adjusted via the manual activation and automatic shutdown of the RCIC system.

It was decided that none of the pumps for the emergency equipment cooling system^{*3} was activatable (the workers later confirmed at the scene that some motors and emergency power supplies (P/C 1C-2, 1D-2) were unusable due to submersion) because the seawater heat exchanger building was flooded by the tsunami and the operation/shut down indication lamp indicated that these pumps shut down. All the ECCS pumps therefore became unactivatable, thus causing loss of the reactor’s residual heat removal function. Moreover, the emergency power supplies (M/C 1C and 1HPCS) became unusable because the annex of the reactor building was submerged by the tsunami, thus making the LPCS pump, RHR pump (A) and HPCS pump unusable.

*3 Pumps for the emergency equipment cooling system:

- Residual Heat Removal Cooling System (hereafter called “RHRC pumps”) pumps (A, B, C, D)
- Residual Heat Removal Cooling Sea Water System (hereafter called “RHRS”) pumps (A, B, C, D)
- Emergency Equipment Cooling Water (hereafter called “EECW”) pumps A, B)
- HPCS Cooling Water System (hereafter called “HPCSC”) pump
- HPCS Cooling Sea Water System (hereafter called “HPCSS”) pump

Initially, the workers poured water onto the reactor using the RCIC system. However, they introduced the alternative method using MUWC at 00:00 on March 12 as a countermeasure for severe accidents and implemented this

along with the RCIC system for injecting water. Furthermore, rapid reactor depressurization was initiated at 03:50 on the same day because the relationship between the reactor pressure and the S/C water temperature turned the situation into the operation prohibition status because of the heat capacity limitation. The workers manually shut down the RCIC system at 04:58 on the same day due to the decrease in the pressure of the steam to drive the RCIC turbine caused by the rapid depressurization of the reactor. Subsequently, they adjusted the reactor water level through the alternative water injection method using MUWC.

At 17:35 on March 11 the alarm went off after detecting the state of "D/W pressure high" (set point: 13.7 kPa [gage]). There was an entry (system A) describing the state of "MSIV reactor water level low (L-2)" in the alarm typer that was recorded at 15:37 of the same day.

It was later discovered that the state of "MSIV reactor water level low (L-2)" (system A) was caused by loss of the MSIV trip logic circuit power supply due to shutdown of the 120 V AC Station vital panel board 1A that was caused by the tsunami. Although the automatic activation signals of all the ECCS pumps properly worked upon detection of the "D/W pressure high" state, of those ECCS pumps, the LPCS pump, the RHR pump (A) and the HPCS pump did not automatically activate because of the unavailable emergency power supplies (M/C1C, 1HPCS). Also, after the automatic activation, the workers manually shut down the RHR pumps (B, C) because the RHRC pumps (B, D), the RHRS pumps (B, D) and the EECW pump (B) were unusable. After this incident, the workers undertook a preventive measure for automatic activation (the control switch is maintained at the "pull" position).

Subsequently, the S/C water temperature increased to over 100°C at 05:22 on March 12. It further increased up to approximately 130°C (at 11:30 on March 13). At 06:20 on March 12 in order to cool down the S/C, the workers injected the coolant (MUWC) into the S/C from the cooler of the Flammability (Gas) Control Diagram (hereafter called "FCS") via the coolant drainage line. At 07:10 on the same day the workers began using the alternative method using MUWC. D/W spraying was initiated at 07:10 and the cooling method was switched to the S/C spraying at 07:37. Thus the workers used PCV alternative cooling by alternating these two methods according to the situation.

Furthermore, along with the implementation of the alternative water injection method using MUWC, the PCV alternative cooling method and the S/C cooling method using the FCS coolant (MUWC), the workers inspected and repaired the following pumps: the RHRC pump (D); the RHRS pump (B); and the EECW pump (B). (Motors were replaced for the RHRC pump (D) and the EECW pump (B).) Additionally, because the seawater heat exchanger building was submerged and the emergency power supplies (P/C 1C-2, 1D-2) were flooded, the workers restored the RHRC pump (D), the RHRS pump (B) and the EECW pump (B) to an activatable state by supplying power from the temporarily installed cable, which received electricity from the power supply (P/C 1WB-1) in the radioactive waste treatment building. This in turn received electricity from an external power supply system and a high voltage power supply vehicle, which had been urgently procured outside the Power Station. These pumps were activated one by one at 20:17 on March 13.

Subsequently, the RHR pump (B) was activated at 1:24 on March 14. Also, as a result of S/C cooling using the RHR pump (B), the S/C water temperature

gradually dropped to a temperature lower than 100°C at 10:15 on the same day.

Furthermore, in order to cool down the reactor water as well as the S/C water at an early stage, the Station created implementation procedures based on the predetermined emergency operation procedures. At 10:05 on the same day the workers began the procedure to inject the S/C water into the reactor via the LPCI line using the RHR pump (B). At the same time, they temporarily cooled the reactor via the circulation line, through which the reactor water was allowed to flow into the S/C through the SRV, and the S/C water was cooled using the RHR heat exchanger (B), then again injected back into the reactor via the LPCI line (S/C → RHR pump (B) → RHR heat exchanger (B) → LPCI line → reactor → SRV → S/C). Through this operation, the Station confirmed that the reactor water temperature dropped to a temperature lower than 100°C at 17:00 on the same day, and thus a cold shutdown was confirmed.

As described above, although the reactor's cooling function was temporarily lost, water was continuously injected into the reactor. As a result of the reactor water sampling conducted after the incident, the level of iodine-131 was lower than the detection threshold. Therefore, it did not damage the fuel.

d. State of the “Confining” function

When the alarm went off detecting the state of “reactor water level low (L-3)” when the reactor automatically shut down, the Primary Containment Isolation System (hereafter called “PCIS”) and the SGTS properly worked. Therefore, the PCV was isolated, and the negative pressure in the reactor building was maintained. Although the PCV pressure increased up to approximately 282 kPa [gage] (at the S/C side), it did not reach the PCV maximum allowable working pressure of 310 kPa [gage].

In addition, no abnormal change was observed in the stack radiation monitor or the MP value. The Station therefore confirmed that no radiation affected the environment outside the building.

Moreover, assuming that the PCV pressure was going to increase and that it would take a while to recover the reactor heat removal function, the workers created a PCV pressure-resistant vent line (the state in which one action for operating the outlet valve at the S/C side was left undone).

e. State of the spent fuel pool cooling system

With regard to systems required for cooling the SFP, the SFP water level was maintained higher than the overflow through the FPC system, and the SFP water temperature was maintained at approximately 38°C before the earthquake. However, the SFP cooling through the FPC could not be continued because the coolant could not be supplied to the FPC heat exchanger due to the disability of some pumps for the following reasons: the FPC pump tripped (“skimmer surge tank water level low” or “pump suction pressure low”) due to the earthquake; the sea water system (hereafter called “SW”) pump (A, B, C) of the closed cooling water system located near the outside intake was flooded by the tsunami; and the Reactor Auxiliary Cooling Water System (hereafter called “RCW”) pump (A, B, C) located at the lower

ground floor in the seawater heat exchanger building was submerged by the tsunami.

Consequently, the SFP water temperature increased up to approximately 62°C. Therefore, the workers injected water into SFP using the Fuel Pool Make-Up Water System (hereafter called “FPMUW”) at 16:30 on March 14, and the water circulation operation using the FPC pump (B) was initiated at 20:26 on the same day to cool the SFP. Subsequently, at 0:42 on March 16 the SFP cooling operation was conducted using the RHR pump (B). By 10:30 on the same day, the SFP water temperature returned to approximately 38°C, which was the temperature prior to the earthquake.

As a result of the above countermeasures, although the SFP system temporarily lost its cooling function, it satisfied the operational limits (SFP water level: near overflow water level, water temperature: 65°C or lower) stipulated by the Safety Preservation Rules of Nuclear Facilities.

f. State of the “Power Supply” function

All the power supplies in the Station were in usable conditions immediately after the automatic shutdown of the reactor. However, because the annex of the reactor building was submerged by the tsunami, the emergency power supplies (M/C 1C and 1HPCS) became disabled. Moreover, because the seawater heat exchanger building was flooded by the tsunami, the emergency power supplies (P/C 1C-2 and 1D-2) became disabled.

At that time, the power supply was cut off from MCC 1C-1-8 because the emergency power supply (M/C 1C) was disabled, thereby shutting down the 120 V AC Station vital panel board 1A, which was its load, thus causing disability to some recorders in the MCR.

In addition, all the emergency DG systems (systems A, B and HPCS) were in usable conditions immediately after the automatic shutdown of the reactor. However, after being flooded by the tsunami, all emergency machinery cooling system pumps became unactivatable. Furthermore, because the annex of the reactor building was also flooded by the tsunami, the DG main unit and its accessory equipment (including pumps, a control panel and MCC) were also flooded, thus disabling all the DG units.

During the subsequent restoration the 120 V AC Station vital panel board 1A was restored to a usable state by receiving electricity from the cable temporarily installed on the temporary supply panel board of Unit 2 (conducted on March 12). Furthermore, with regard to the disabled emergency power supply (P/C 1D-2), the RHRC pump (D) and the RHRS pump (B), all of which were required for cooling the reactor and the SFP, received electricity from the power supply (P/C 1WB-1) of the Radioactive Waste Disposal Building via the temporarily installed cable. Also, the EECW pump (B) received electricity from a high voltage power supply vehicle (conducted on March 13 and 14).

Subsequently, the workers switched the temporary power supply for the EECW pump (B) from the high voltage power supply vehicle to the emergency power supply (P/C 1D-1) (switched on March 30). In addition, expecting to lose the external power supply system, the Station devised procedures to receive electricity from the emergency power supplies of Units 2 and 3 (M/C

2D and M/C 3D, respectively) as a backup power supply system for the DG (B) of the usable emergency power supply (M/C 1D) (conducted on April 21).

In addition, even if the external power supply systems fail, the emergency power supplies (M/C 2D and 3D) can receive electricity from DGs (B) of Units 2 and 3 because they are in a usable condition.

Moreover, Unit 1's DG (B) was also restored on July 15. Thus all the emergency power supplies required for cooling the reactor and the SFP have been secured.

Table Appendix 3-1 Fukushima Daini Nuclear Power Station Unit 1 Situation in Chronological Order After the Earthquake

Friday, March 11, 2011

- 14:46 Great East Japan Earthquake occurs.
- 14:48 The reactor automatically shuts down. (The alarm goes off detecting the state of “high seismic acceleration trip.”) All control rods are fully inserted.
- 14:48 One of the Tomioka circuits shuts down (number 2 trips, the system continues to receive electricity from number 1).
- 15:00 The subcriticality of the reactor is confirmed.
- 15:22 The first tsunami wave is confirmed. (From then the tsunami is continuously confirmed until 17:14.)
- 15:33 The CWP (C) is manually shut down.
- 15:34 DGs (A), (B) and (H) are automatically activated. Immediately after the activation, they shut down due to the tsunami.
- 15:36 The MSIV is fully closed manually.
- 15:36 The RCIC system is manually activated. (Subsequently, the system starts and stops randomly.)
- 15:50 All Iwaido circuits shut down.
(Number 2 shuts down. Number 1 was not operated before the earthquake because it was undergoing an inspection.)
- 15:55 The reactor depressurization is initiated (the SRV automatically opens). (Subsequently, reactor pressure is controlled through automatic and manual switches.)
- 15:57 The CWPs (A) and (B) automatically shut down.
- 17:35 The alarm goes off detecting the state of “D/W pressure high.” There is an entry describing the state of “MSIV reactor water level low (L-2)” in the alarm typer at 15:37 of the same day. Based on these facts, we cannot deny the possibility that the cause of the pressure increase could be a leakage of reactor coolant in the PCV. The Station therefore determines that the specified events (leakage of reactor coolant) stipulated in Article 10, Paragraph 1 of the Special Law for Nuclear Emergency have occurred. (As a result of the inspection on the relevant parameters subsequently conducted, no reactor coolant leakage is observed. Therefore, at around 18:33 on the same day, the Station determined that the situation does not fall under the above event.)
- 17:53 The D/W cooling system is manually activated.
- 18:33 Based on the fact that the activation of the seawater pump that has the function to remove heat from a reactor cannot be confirmed, the Station determines that the specified event (loss of the function to remove heat from a reactor) stipulated in Article 10, Paragraph 1 of the Special Law for Nuclear Emergency has occurred.

Saturday, March 12, 2011

- 00:00 MUWC alternative water injection is initiated.
- 03:50 Rapid depressurization of the reactor is initiated.
(This is because the situation has turned into the operation prohibition status regarding thermal capacity limit.)
- 04:56 Rapid depressurization of the reactor is complete.

- 04:58 The RCIC is manually shut down (operation prohibition due to the reactor pressure decrease).
- 05:22 Because the S/C temperature has exceeded 100°C, the Station determines that the specified event (loss of the pressure suppression function) stipulated in Article 15, Paragraph 1 of the Special Law for Nuclear Emergency has occurred.
- 05:58 The alarm goes off detecting the abnormality in control rod 10-51 PIP
- 06:20 The S/C cooling operation using the FCS coolant (MUWC) is conducted.
- 07:10 The D/W spraying operation using MUWC is conducted. (From this point forward, it has been conducted according to the situation.)
- 07:37 The S/C spraying operation using MUWC is conducted. (From this point forward, it has been conducted according to the situation.)
- 07:45 The S/C cooling operation using the FCS coolant (MUWC) is terminated.
- 10:21 Creation of the PCV pressure-resistant vent line is initiated.
- 10:30 The alarm for the abnormality in control rod 10-51 PIP is cleared. (Subsequently, it repeatedly goes off and becomes cleared several times.)
- Around 13:38 One of Iwaido circuits begins receiving electricity. (The restoration of Unit 2 has been completed.)
- 18:30 Creation of the PCV pressure-resistant vent line is complete.

Sunday, March 13, 2011

- 05:15 (approx.) Two Iwaido circuits begin receiving electricity. (The restoration of Unit 1 has been completed.)
- 20:17 The RHRS pump (B) is manually activated. (Electricity is received from P/C 1WB-1 through the temporarily installed cable.)
- 21:03 The RHRC pump (D) is manually activated. (Motor replacement/receiving electricity from P/C 1WB-1 through the temporarily installed cable.)

Monday, March 14, 2011

- 01:24 Due to the manual activation of the RHR (B) pump (the initiation of the S/C cooling mode) and the activation of the RHR (B) pump, the Station determines that the situation does not fall under the specified event (loss of the function to remove heat from a reactor) stipulated in Article 10, Paragraph 1 of the Special Law for Nuclear Emergency.
- 01:44 The EECW (B) is manually activated. (motor replacement/receiving electricity from the high voltage power supply vehicle)
- 03:39 The RHR (B) S/C spray mode is initiated.
- 10:05 The water pouring operation onto the reactor is conducted under the RHR (B) LPCI mode.
- 10:15 Because the S/C water temperature has dropped to lower than 100°C, the Station determines that the situation has recovered from the specified event (loss of the pressure suppression function) stipulated in Article 15, Paragraph 1 of the Special Law for Nuclear Emergency.

- 16:30 The water pouring operation through the FPMUW system is initiated to cool down the SFP.
- 17:00 Because the reactor water temperature has dropped to lower than 100°C, the reactor cooling operation is terminated.
- 20:26 Circulation operation of the FPC (B) is initiated.
- 22:07 Because the radiation level that exceeds 5 µGy/h is measured at the MP (No. 1), the Station determines that the specified event (increase in the site boundary radiation dose) stipulated in Article 10, Paragraph 1 of the Special Law for Nuclear Emergency has occurred. (It can be surmised that the increase in the radiation dose was caused by radioactive materials discharged into the atmosphere upon the occurrence of the accident at Fukushima Daiichi.)

Tuesday, March 15, 2011

- 00:12 Because a radiation level exceeding 5 µGy/h is measured at the MP (No. 3), the Station determines that the specified event (increase in the site boundary radiation dose) stipulated in Article 10, Paragraph 1 of the Special Law for Nuclear Emergency has occurred. (It can be surmised that the increase in the radiation dose was caused by radioactive materials discharged into the atmosphere upon accident at Fukushima Daiichi.)

Wednesday, March 16, 2011

- 00:42 The RHR (B) SFP cooling operation is initiated.
- 10:30 The SFP water temperature of approximately 38°C is confirmed. (It returned to the temperature before the earthquake.)

(3) Unit 2

a. Station behavior upon occurrence of the earthquake

The reactor was running at normal rated heat output when an earthquake centered on the Sanriku-coast occurred at 14:46 on March 11, 2011. The reactor automatically shut down its operation at 14:48 on the same day with a “high seismic acceleration trip” alert. Immediately thereafter, full-insertion of all control rods (CR) and the reactor’s subcriticality were confirmed. The Station also confirmed that equipment necessary for the reactor’s cold shutdown and cooling of SFP were in a sound and stable condition.

However, due to the tsunami after the earthquake (1st tsunami was visually confirmed at 15:22, on the same day), these pieces of equipment, which are necessary for cold shutdown of the reactor and SFP cooling, became disabled because of water intrusion and such like. Also, S/C cooling was not possible due to loss of the reactor heat removal function, and S/C water temperature gradually rose up to over 100°C.

Later, to enable part of the equipment for reactor cold shutdown and SFP cooling, the workers inspected and repaired the submerged equipment. Also, power supply was obtained from a temporary power supply. After recovery of the reactor’s heat removal function, S/C cooling was performed, and the S/C water temperature fell below 100°C. Thereafter, by RHR1 system, the reactor maintained its cold shutdown with the water temperature below 100°C until 18:00 on March 14. At the same time, SFP was being continuously cooled down, and the Station has currently been maintaining its stable condition.

b. State of the “Stopping” function

The earthquake triggered a “high seismic acceleration trip” alert at 14:48 (operational set point in vertical direction in reactor building underground 2nd floor: 100 gal), which immediately led to full-insertion of all control rods. The reactor automatically shut down as designed and became subcritical at 15:01.

c. State of the “Cooling” function

Shortly after automatic shutdown of the reactor, a void (coefficient) in the core of the reactor decreased due to the sharp decline of the reactor output. The water level of the reactor dropped down to “reactor vessel low water level (L3).” After that, with the water supply from the reactor’s feedwater system, the water level was recovered and did not drop to the point at which the ECCS pump and RCIC would automatically start.

At 15:34 on March 11, the Main Steam Isolation Valve (MSIV) was fully closed manually, and the reactor’s pressure control was implemented by SRV. The workers took this measure to prepare for the situation where the condenser fails to condense main steam, following CWP shutdown due to the tsunami, and in the case of losing turbine ground seal steam, following shutdown of the auxiliary boiler due to impact of the earthquake.

With MSIV fully-closed, RCIC was manually activated at 15:43, and the workers injected water into the reactor. After RCIC’s automatic shutdown at 15:46 on the same day by “reactor vessel low water level (L8),” the reactor’s water level was adjusted by manual start-up and automatic shutdown of RCIC.

Based on indication of the operation and shut off lamp displays and the fact that seawater heat exchanger was flooded by the tsunami, the Station determined that RHRC pump (A, B, C, D), RHRS pump (A, B, C, D), EECW pump (A, B) and HPCSC pump could not be started (the Station confirmed later that pumps were inoperable due to water exposure on a part of the monitors and emergency power supply (P/C 2C-2, 2D-2). Thus, all ECCS pumps became unusable, and the function of removing residual heat from the reactor was lost.

Initially, the workers injected water into the reactor by RCIC. However, with the opening of SRV, the reactor pressure lowered. Accordingly, at 04:50 on March 12, the workers began to inject water by MUWC based on the operation procedure manual. This was implemented as a severe accident countermeasure. RCIC automatically shut down at 04:53 on the same day, due to lower steam pressure for the RCIC turbine caused by depressurization of the reactor. Subsequently, the workers adjusted the reactor's water level by conducting an alternative water injection with MUWC.

With the operation of RCIC and opening of SRV, the temperature and pressure inside PCV increased. However, as cooling with RHR pump (A,B) was not possible, an alarm signal was triggered at 18:50 on March 11, indicating "high D/W pressure" (design value: 13.7 kPa [gage]).

As a result, all ECCS pump's auto-start signals were issued. However, as RHRC pump (A, B, C, D), RHRS pump (A, B, C, D), EECW pump (A, B) and HPCSC pump were disabled, workers conducted a manual shutdown after startup. After this, the auto-start prevention measure (hold pull of control switch) was implemented.

Later on at 05:32 on March 12, the S/C water temperature rose to over 100°C. The temperature rose up to approximately 139°C at 07:00 on March 14.

To cool down the S/C, from 06:30 on March 12, the workers injected MUWP, which is cooling water, into the S/C using the cooling water drain line from the FCS's cooler to the S/C. Alternative injection into the reactor by MUWC was changed into D/W spray from 07:11 on the same day, and changed into S/C spray from 07:35 as necessary to perform alternative cooling of PCV.

The workers inspected and repaired the RHRC pump (B), RHRS pump (B) and EECW pump (B) along with conducting an alternative injection into the reactor by MUWC, PCV alternative cooling and S/C cooling by FCS cooling water (MUWP). The seawater heat exchanger building and emergency power supply unit (P/C 2C-2, 2D-2) were submerged in water. Therefore, temporary cables that had been obtained offsite were used to feed emergency power. Power was supplied from the Radioactive Waste Disposal Building (P/C 1WB-1) receiving power from the external power system. Power was also received from the Unit 3 heat exchanger building emergency power (P/C3D-2) by installation of temporary cables. By reception of this power, RHRC pump (B), RHRS pump (B) and EECW pump (B) recovered their function and started sequentially from 03:20 on March 14.

Later on, RHR pump (B) started from 07:13 on March 14. Also, S/C cooling performed by RHR pump (B) resulted in a gradual decline in the S/C water temperature. By 15:52 on the same day, the S/C water temperature had fallen to below 100°C.

To promptly cool down the reactor water as well as S/C water, the Station created an implementing procedure manual using a previously formulated

accident operation manual as reference. From 10:48 on the same day, the workers injected S/C water into the reactor by RHR pump (B) via LPCI line. At the same time, the reactor water flowed into S/C via SRV, and the S/C water was cooled by RHR heat exchanger (B) to re-inject into the reactor via LPCI line again. Such circulation line (S/C → RHR pump (B) → RHR heat exchanger (B) → LPCI line → Reactor → SRV → S/C) was implemented as an emergency cooling measure. The Station confirmed that this measure cooled down the reactor temperature to below 100°C at 18:00 on the same day.

The above indicates that despite a temporary loss of the reactor's cooling function, water injection into the reactor was continued. Later sampling of the reactor water showed that iodine 131 was below detection limit. Thus, no fuel damage occurred.

d. State of the “Confining” function

With “reactor vessel low water level (L3)” alert triggered at the reactor's automatic shutdown, PCIS and SGTS operated normally, and PCV was isolated, and reactor building subatmospheric pressure was maintained. The PCV pressure increased up to approximately 279 kPa [gage] (on S/C), but it did not reach the maximum operating pressure of 310 kPa [gage].

The Station confirmed that there was no abnormal change in the stack radiation monitor or MP values, or radiation impact to the outside.

Assuming PCV pressure's tendency to increase and the long recovery time for the reactor's heat removal function, the workers used a line configuration for PCV pressure vent (one action remained to be done for an operation to open the outlet valve on S/C).

e. State of the spent fuel pool cooling system

As for the equipment necessary for cooling of SFP, FPC had maintained the SFP water temperature at about 32.5°C and the water level higher than the level of overflow water prior to the earthquake. Due to the impact of the earthquake, the FPC pump tripped (“low water level of skimmer surge tank” or “low pump pressure”). The tsunami flooded the SW pump (A, B, C) in the non-safety service water system near the outside water intake. The RCW pump on the first basement level of the seawater heat exchanger building was also under water and unusable. For these reasons, cooling water was not supplied to the FPC heat exchanger, and SFP cooling by FPC was not possible.

This raised the SFP water temperature up to about 56°C, but workers started cooling the SFP by RHP pump (B) from 01:28 on March 16, and by 10:30 on the same day, the temperature was down to about 32.5°C, the same level as that before the earthquake.

The above indicates that while cooling function was also temporarily lost on SFP, operational limits (SFP water level; near the level of overflow; water temperature; 65°C or lower) specified under the Safety Preservation Rules of Nuclear Facilities were met.

f. State of the “Power Supply” function

Immediately after automatic shutdown of the reactor, the facility’s power system was usable. However, as the seawater heat exchanger building was submerged due to the tsunami, the emergency power supply (P/C 2C-2 and 2D-2) became unusable.

Emergency DGs (Systems A, B and HPCS) were all usable right after the reactor’s automatic shutdown, but after the tsunami reached the facility, it was not possible to start RHRS pump (A, B, C, D), EECW pump (A, B) and HPCSC. As a result, all emergency DGs became unusable.

Through the recovery afterwards, out of the power loads of disabled emergency power (P/C 2D-2), the following secured power by temporary cable installation (performed on March 14): Power for RHRC pump (B) and RHRS pump (B) necessary for cooling the reactor and SFP was supplied from the power supply (P/C 1WB-1) of the Radioactive Waste Disposal Building. EECW pump (B) received power from the emergency power supply (P/C 3D-2) of the Unit 3 heat exchanger building.

As the above measure enabled use of RHRC pump (B), RHRS pump (B) and EECW pump (B), emergency power (M/C 2D) became available via DG (B) even if external power supply was lost. From April 2, DG (HPCS) became usable, thus emergency power supply for cooling of the reactor and SFP has been secured.

Table Appendix 3-2 Fukushima Daini Nuclear Power Station Unit 2 Situation in Chronological Order After the Occurrence of the Earthquake

Friday, March, 11, 2011

- 14:46 Great East Japan Earthquake occurred.
- 14:48 Automatic shutdown of reactor (“high seismic acceleration trip” alert was triggered and all control rods were fully inserted.)
- 14:48 Tomioka line No. 1 shutdown (No. 2 was tripped, power continued to be received from No. 1.)
- 15:01 Reactor’s subcritical status confirmed
- 15:22 The first tsunami was confirmed (thereafter, tsunami waves were confirmed intermittently until 17:14)
- 15:34 DG (H) automatically started / immediately thereafter it shut down due to tsunami impact
- 15:34 MSIV fully closed manually
- 15:35 RHR (B) manually started (shut down at 15:38)
- 15:35 CWP (C) manually shut down, CWP (A) (B) automatically shut down
- 15:41 DG (A) (B) automatically started / immediately thereafter shut down due to tsunami impact
- 15:41 Depressurization of the reactor commenced (SRV automatically opened) (thereafter, valve was repeatedly opened and closed to control reactor pressure)
- 15:43 RCIC manually started (thereafter, starts-stops occurred as the circumstances demand)
- 15:50 Iwaido line fully shut down (No. 2 shutdown, No. 1 had been shut down for checkup before earthquake)
- 18:33 Because startup of a seawater pump for equipment having capability to remove heat from the reactor could not be confirmed, the Station determined that an event specified under Article 10, Paragraph 1 of Special Law for Nuclear Emergency had occurred (loss of reactor heat removal capability).
- 18:50 “High D/W pressure” alert was issued.
- 20:02 Drywell cooling system manually startup

Saturday, March 12, 2011

- 04:50 Alternative water injection started using the make-up water condensate system (MUWC)
- 04:53 RCIC automatically shut down (due to lower reactor pressure)
- 05:32 Because S/C temperature had risen above 100°C, the Station determined that an event specified under Article 15, Paragraph 1 of Special Law for Nuclear Emergency had taken place (loss of pressure suppression capability)
- 06:30 S/C cooling implemented using coolant (MUWP) from flammable control system (FCS).
- 07:11 D/W spraying implemented using MUWC (thereafter implemented as circumstances demanded)
- 07:35 S/C spraying implemented using MUWC (thereafter implemented as circumstances demanded)
- 07:52 S/C cooling using FCS coolant (MUWP) shut down
- 10:33 Configuration of PCV hardened venting line commenced
- 10:58 Configuration of PCV hardened venting line completed

13:38 (approx.)

Power received from Iwaido line No. 1 (No. 2 restored)

Sunday, March 13, 2011

05:15 (approx.)

Power received from Iwaid line No. 2 (No. 1 restored)

Monday, March 14 2011

03:20 EECW (B) manually started up

(Power received from P/C 3D-2 via temporary cable)

03:51 RHRS (B) manually started up

(Power received from P/C 1WB-1 via temporary cable)

05:52 RHRC (B) manually started up

(Power received from P/C 1WB-1 via temporary cable)

07:13 RHR (B) manually started up (S/C cooling mode commenced)

With startup of RHR (B), it was determined to cancel the occurrence of a special event (loss of capability to remove heat from reactor) under the provision of Article 10, Paragraph 1 of Special Law for Nuclear Emergency.

07:50 RHR (B) S/C spraying mode commenced

10:48 Coolant injection into reactor was started in RHR (B) low pressure coolant injection (LPCI) mode

15:52 Because S/C temperature had fallen below 100°C, the Station determined that the Station had recovered from the event specified under Article 15, Paragraph 1 of Special Law for Nuclear Emergency (loss of pressure suppression capability)

18:00 Reactor water temperature had fallen below 100°C, and cold shutdown of reactor achieved.

22:07 As radiation dose measured exceeded 5 µGy/h at MP (No. 1), the Station determined that a special event (increase in radiation dose in site boundary) under the provision of Article 10, Paragraph 1 of Special Law for Nuclear Emergency took place (the cause of the dose increase is surmised to be due to the effects of radioactive material released into the atmosphere, following the accident at Fukushima Daiichi Nuclear Power Station).

Tuesday, March 15, 2011

00:12 As radiation dose measured exceeded 5 µGy/h at MP (No. 3), the Station determined that a special event (increase in radiation dose in site boundary) under the provision of Article 10, Paragraph 1 of Special Law for Nuclear Emergency had taken place (the cause of the dose increase is surmised to be due to the effects of radioactive material released into the atmosphere, following the accident at Fukushima Daiichi Nuclear Power Station).

Wednesday, March 16, 2011

01:28 RHR (B) commenced cooling of SFP

10:30 SFP water temperature was confirmed to be about 32.5°C (recovered to the temperature before the earthquake)

(4) Unit 3

a. Station behavior upon occurrence of the earthquake

The Station was in operation at a constant rate thermal power when the earthquake occurred at 14:46 on March 11, 2011. The earthquake's epicenter was offshore of Sanriku. At 14:48 on the same day, the reactor automatically shut down due to "high seismic acceleration trip" alert. Immediately thereafter, all control rods were fully inserted, and the reactor's subcriticality was confirmed. The Station also confirmed that equipment necessary for the reactor's cold shutdown and cooling of SFP were steadily operating in sound condition.

While equipment for the reactor's cold shutdown and cooling of SFP became partially disabled, cooling of the reactor was implemented from March 12, using RHR1 system which was operatable without impacts of the tsunami. A cold shutdown of the reactor was confirmed on the same day.

b. State of the "Stopping" function

Due to the earthquake, "high seismic acceleration trip" alert (reactor building underground 2nd floor, operational set point value in horizontal direction: 135 gal) was issued at 14:48. Immediately thereafter, all control rods were fully inserted. The reactor automatically shut down as designed, and it was in subcritical state at 15:05 on the same day.

c. State of the "Cooling" function

Immediately after the reactor's automatic shutdown, the void in the reactor core decreased, following drastic decline of reactor output. The water level of the reactor decreased to "reactor vessel low water level (L3)." With water supply from the reactor's feedwater system, the water level of the reactor was later recovered and did not drop to the point at which the ECCS pump and RCIC would automatically start. On March 11, at 15:37, the Main Steam Isolation Valve (MSIV) was fully closed manually, and the reactor's pressure control was implemented by SRV. The workers took this measure to prepare for the situation where the condenser fails to condense main steam, following CWP shutdown due to the tsunami, and loss of turbine ground seal steam, following shutdown of auxiliary boiler due to earthquake impact.

With full opening of MSIV, Reactor Core Isolation Cooling (RCIC) was manually started at 16:06 on the same day, and water was injected into the reactor.

Due to the fact that the seawater heat exchanger building was flooded by the tsunami along with indication by operation on/off lamp, the Station determined that RHRC pump (A, C), RHRS pump (A, C) and EECW pump (A) could not be started (the Station confirmed later at the Station site that these pumps were not usable because the motors and emergency power supply (P/C 3C-2) were partially flooded). For this reason, it was not possible to start LPCS pump and RHR pump (A).

As for the emergency power supply (P/C 3D-2) and its load, RHRC pump (B, D), RHRS pump (B, D) and EECW pump (B) as well as HPCSC pump and HPCSS pump, the amount of seawater exposure to the seawater heat

exchanger building was smaller compared with other units. Based on this reason, these pumps were presumed to be usable as there was little impact of inundation on this equipment.

Also, RHR pump (B, C) and HPCS pump were usable because there was no water intrusion caused by the tsunami in the 2nd underground floor of the reactor ward of reactor building.

Water injection into the reactor was initially performed by RCIC. However, from 22:53 on March 11, alternative water injection by MUWC introduced as a severe accident countermeasure, was also implemented. Later, lower reactor pressure due to SRV opening reduced steam pressure for RCIC turbine operation. This led to manual shutdown of RCIC at 23:11 on the same day. Thereafter, alternative water injection using MUWC had been performed. However, at 00:06, on the same day, workers implemented water injection and cooling by the usable RHR pump (B). At 12:15 on March 12, the reactor's water temperature fell below 100°C, and its cold shutdown was confirmed.

At 19:46 on March 11, "high D/W pressure (design value: 13.7 kPa [gage]) alert was issued due to temperature and pressure rise inside PCV, following RCIC operation and SRV opening. This was followed by the automatic start-up signal for all ECCS pumps. However, HPCS pump, LPCS pump and RHR pump (A,C) were not automatically started because the automatic start prevention measure was in place (hold pulling control switch) due to the disabled cooling system (RHRC (A, C), RHRS (A, C) and EECW(A)). RHR pump (B) was in operation for cooling of S/C at "high D/W pressure" alert (started at 15:36 on March 11).

Based on the above, we found that fuel was not damaged as the reactor's cooling function was maintained. Later sampling of the reactor water confirmed that iodine-131 was below detection limits.

d. State of the "Confining" function

With "reactor vessel low water level (L3)" alert issued at automatic shutdown of the reactor, Primary Containment Isolation System (PCIS) and Standby Gas Treatment System (SGTS) were operating normally, and PVC isolation and maintenance of the reactor's subatmospheric pressure were conducted. PCV pressure rose up to about 38 kPa [gage] at D/W, but it did not reach PCV's maximum operating pressure, 310 kPa [gage].

Also, the Station confirmed that there was no abnormal change in stack radiation monitor and MP values, or radiation impact to the outside.

To prevent rising PCV pressure, the workers implemented a line configuration of PCV hardened venting line (one action remained for an operation to open the outlet valve on the S/C).

e. State of the spent fuel pool cooling system

The following describes the condition of equipment necessary for cooling of Spent Fuel Pit (SFP). Before the earthquake, Fuel Pool Cooling & Filtering System (FPC) had maintained SFP's water level above the overflow level and kept SFP's water temperature at about 34°C. Yet, with the impact of the earthquake, FPC pump tripped ("low water level of skimmer surge" tank or

“low pump pressure”). At the same time, due to the tsunami impact, SW pump (A, B, C) in Non-safety Service Water System placed near water intake outside was flooded and became unusable. Also, RCW pumps (A, B, C) in the first basement level of the seawater heat exchanger building were submerged and disabled. For these reasons, cooling water was not supplied to the FPC heat exchanger, thereby disabling SFP cooling by FPC.

These events raised the SFP water temperature to about 51°C. However, from 17:42 on March 15, the workers switched the cooling water of FPC heat exchanger from RCW to RHRC. By this measure, SFP cooling by FPC was implemented. At 22:30 on March 16, SFP’s water temperature was restored back to about 34.0°C, the same level prior to the earthquake.

Based on the above, we found that while SFP suffered a temporary loss of cooling capability, it met operational limits (SFP water level: about overflow level, water temperature; below 65°C) specified under the Safety Preservation Rules of Nuclear Facilities.

f. State of the “Power Supply” function

Immediately after the reactor’s automatic shutdown, all power systems in the facility were usable. However, as the seawater heat exchanger building was flooded by the tsunami, emergency power (P/C 3C-2) became unusable.

Also, emergency diesel generators (DG) were all (A system, B system and HPCS system) usable right after reactor’s automatic shutdown. However, after the tsunami reached the facility, it was not possible to start RHRS (A, C) pump and EECW (A) pump. As a result, DG (A) became unusable.

Since DG (B) and DG (HPCS) were usable, emergency power (M/C 3D and 3HPCS) were receivable by DG (B, HPCS) even in the event of losing external power supply.

Based on the above, we found that emergency power necessary for cooling of the reactor and SFP were secured.

Table Appendix 3-3 Fukushima Daini Nuclear Power Station Unit 3 Situation in Chronological Order After the Occurrence of the Earthquake

Friday, March 11, 2011

- 14:46 Great East Japan Earthquake occurred
- 14:48 Automatic shutdown of the reactor (“high seismic acceleration trip” alert was issued), and all control rods were fully inserted
- 14:48 Tomioka line No. 1 shutdown (No. 2 tripped, power continued to be received by No. 1)
- 15:05 Reactor’s subcriticality confirmed
- 15:22 The first tsunami was confirmed (thereafter, tsunami waves were confirmed intermittently until 17:14)
- 15:34 CWP (C) Manual shutdown
- 15:35 DG (A) (B) (H) automatic startup/Immediately after that DG (A) shutdown due to tsunami impact
- 15:36 RHR (B) Manual startup (S/C cooling mode commenced)
- 15:37 MSIV fully closed manually
- 15:38 CWP (B) Manual shutdown
- 15:46 Depressurization of the reactor commenced (SRV automatically opened) (thereafter, valve was opened and closed both automatically and manually to control reactor pressure)
- 15:50 Iwaido line fully shutdown (No. 2 shutdown, No. 1 had been shut down for checkup before the earthquake)
- 16:06 RCIC manually started (thereafter, starts-stops occurred as the circumstances demand)
- 16:48 CWP (A) Manual shutdown
- 19:46 “High D/W pressure” alert was issued (RHR (B) automatically switched from S/C cooling mode to LPCI mode)
- 20:07 RHR (B) switched from LPCI mode to S/C cooling mode
- 20:12 D/W cooling system manually started
- 22:53 Alternative water injection using MUWC commenced
- 23:11 RCIC manual shutdown (due to lower reactor pressure)

Saturday, March 12, 2011

- 00:06 RHR (B) Commenced preparation for SHC mode configuration
- 01:23 RHR (B) manual shutdown (to prepare for SHC mode)
- 02:39 RHR (B) Manual startup (S/C cooling mode commenced)
- 02:41 RHR (B) S/C spraying mode commenced
- 07:59 RHR (B) Manual shutdown (S/C cooling mode and S/C spraying mode shutdown)
- 09:37 RHR (B) Manual startup (SHC mode operation commenced)
- 12:08 Configuration of PCV hardened venting line commenced
- 12:13 Configuration of PCV hardened venting line completed
- 12:15 Water temperature of the reactor fell below 100°C, and reactor cold shutdown achieved
- 13:38 (approx.)
Power received by Iwaido line No. 1 (No. 2 restored)

Sunday, March 13, 2011

- 05:15 (approx.)
Power received by Iwaido line No. 2 (No. 1 restored)

Monday, March 14, 2011

22:07 As the radiation dose exceeded 5 $\mu\text{Gy/h}$ at MP (No. 1), the Station determined that a special event (increase in radiation dose in site boundary) under the provision of Article 10, Paragraph 1 of Special Law for Nuclear Emergency had occurred (the cause of the dose increase is surmised to be due to the effects of radioactive material released into the atmosphere, following the accident at Fukushima Daiichi Nuclear Power Station).

Tuesday, March 15, 2011

00:12 As the radiation dose exceeded 5 $\mu\text{Gy/h}$ at MP (No. 3), the Station determined that a special event (increase in radiation dose in site boundary) under the provision of Article 10, Paragraph 1 of Special Law for Nuclear Emergency had occurred (the cause of the dose increase is surmised to be due to the effects of radioactive material released into the atmosphere, following the accident at Fukushima Daiichi Nuclear Power Station).

17:42 FPC heat exchanger cooling water was switched (RCW \rightarrow RHRC)

Wednesday, March 16, 2011

22:30 SFP water temperature was confirmed to be about 34°C (recovered to the temperature of that before the earthquake)

(5) Unit 4

a. Station behavior upon occurrence of the earthquake

During the constant thermal output rated operation, due to the Great East Japan Earthquake that occurred at 14:46 on March 11, 2011 with its epicenter off the coast of the Sanriku region, the reactor automatically shut down by “high seismic acceleration trip” at 14:48 on the same day. Right after the event, ensuring that all control rods were fully inserted and the reactor was subcritical, all facilities necessary for cold shutdown of the reactor and SFP cooling were confirmed to have integrity and be in a stable condition.

However, because of the tsunami after the quake (the first wave was visually observed to reach at 15:22 on the same day) the facilities necessary for cold shutdown and SFP cooling were submerged in water and unavailable.

In addition, S/C cooling was unavailable due to the loss of heat removal function of the reactor, and then the S/C water temperature gradually rose and exceeded 100°C.

After those events, in order to recover part of the facilities for cold shutdown of the reactor and SFP cooling, the workers checked and repaired the submerged facilities, and power supply from the temporary source was started. By cooling S/C after the recovery of heat removal function of the reactor, the S/C water temperature dropped under 100°C. From that time on, by using RHR1 system the water temperature of the reactor was lowered to less than 100°C and kept in a cold shutdown state by 07:15 on March 15, SFP has been continuously cooled down, and the Station is currently kept stable.

b. State of the “Stopping” function

The earthquake caused “high seismic acceleration trip” (on the second floor of the reactor building, the horizontal trip value setting: 150 gal) to be issued at 14:48, and then all of the control rods were fully inserted immediately.

The reactor automatically shut down as designed, and it became subcritical at 15:05 on the same day.

A drift alarm on control rods 10 to 19 was issued at 12:43 on March 13, which was cleared at 20:19 on March 14 but was issued again at 21:07 on March 14. The control rod position was readable both with the indicator of “fully inserted” and the display of position itself. When the alarm was issued, the control rod status was presented as “fully inserted” with the indicator lit while the position display was unlit.

When the alarm was issued, no significant change was observed in SRNM indication and the reactor remained subcritical. The control rod status was presented as fully inserted. The drift alarm was continuously issued, and in order to stop it the countermeasure was taken by isolating the control rod (valve out) at 16:56 on March 15. From that time on, no significant change has been observed in SRNM and the reactor remains subcritical.

c. State of “Cooling” function

Just after the reactor automatically shut down, the reactor water level dropped to “reactor vessel low water level (L-3)” as voids inside the core decreased due to the steep drop of reactor output. Later, the reactor water level recovered by

supply from the reactor feedwater system without dropping to the level to automatically start ECCS pump and RCIC.

For the possibility of stop of CWP and subsequent outage of main steam condensation by the condenser due to damage from tsunami, and for the possibility of loss of steam in the turbine gland seal caused by stop of auxiliary boiler due to the quake, MSIV was fully closed by manual operation at 15:36 on March 11 to control the pressure of the reactor by SRV.

Along with a full close of MSIV, RCIC was manually started at 15:54 on the same day to inject water to the reactor. And then, after the automatic stop of RCIC due to "reactor vessel high water level (L-8)" at 16:11 on the same day, the reactor water level was controlled by manual start and automatic stop of RCIC.

Judging from the fact that the seawater heat exchanger was submerged in water due to the tsunami and from the lamps to indicate operating/halt, RHRC pumps (A, B, C, D), RHRS pumps (A, B, C, D) and EECW pumps (A, B) were estimated as inoperable (some of the motors and power supplies (P/C 4C-2, 4D-2) were confirmed at the site on the later day as being inoperable because of submersion). In that situation, LPCS pumps and RHR pumps (A, B, C) were inoperable, and therefore the function to remove the residual heat of the reactor was lost.

The Station estimated that HPCSC pumps and HPCSS pumps were available because they suffered less damage from water submersion as there was less amount of seawater in the pump area inside the seawater heat exchanger building in comparison to other pumps. In addition, as there was no inundation on the second basement floor of the reactor building, HPCS pumps were in an operable condition.

Workers initially injected water to the reactor by RCIC, but because the steam pressure to drive RCIC turbine decreased due to the reactor pressure drop caused by the opened SRV, after the automatic stop of RCIC at 00:16 on March 12, alternative water injection was started according to the operation manual by MUWC. The Station had created this manual as a countermeasure to severe accidents. From that time on, the reactor water level was adjusted by starting and stopping the HPCS pumps which were operable without damage from the tsunami.

The temperature and pressure inside the PCV increased along with the operation of RCIC and opening of SRV. Because the cooling by RHR pumps (A, B) was not available, "high D/W pressure" (setting: 13.7 kPa [gage]) was issued on 19:02 on March 11.

The signal to automatically start all of the ECCS pumps was generated along with that alarm, but the workers injected the water into the reactor by RCIC and the automatic start was prevented (the control switch was pulled and hold) because the cooling system (RHRC, RHRS and EECW) was not operable, each ECCS pump was not automatically started.

After those events, S/C water temperature exceeded 100°C at 06:07 on March 12. The S/C water temperature has reached a maximum of 137°C (12:30 on March 14).

In order to cool down S/C, the workers started to inject cooling water (MUWP) to S/C at 07:23 on March 12 by using cooling water drain lines from FCS

cooler to S/C. In addition, they performed alternative cooling of PCV at 07:35 by switching over to S/C spray from alternative water injection by MUWC.

In conjunction with the alternative water injection to the reactor by MUWC, the alternative cooling of PCV and the cooling of S/C by FCS cooling water (MUWP), RHRC pump (B), RHRS pump (D) and EECW pump (B) (the motor was replaced for RHRC pump (B)) were checked and repaired. Because the seawater heat exchanger building was submerged and its emergency power supplies (PC 4C-2, 4D-2) were inundated, high voltage power supply vehicles and temporary power cords were urgently prepared from outside the site and used. By installing temporary power cords and receiving power from the emergency power supply (P/C 3D-2) of the heat exchanger building of Unit 3 whose power was supplied from the electric system outside and by receiving power from the high voltage power supply vehicles, RHRC pump (B), RHRS pump (D) and EECW pump (B) were recovered to operable conditions, and then they were started one by one from 11:00 on March 14.

After that, RHR pump (B) was started at 15:42 on March 14.

As a result of S/C cooling by RHR pump (B), the S/C water temperature started gradually dropping and fell under 100°C at 07:15 on March 15.

Furthermore, in order to quickly cool down the reactor water in addition to the cooling of S/C water, the Station improvised an implementation procedure by referring to the predefined emergency operation manual. Along with the start of S/C water injection to the reactor by RHR pump (B) from LPCI line at 18:58 on the same day, the emergency cooling procedure with the circulating line was performed by flowing the reactor water into S/C via SRV, cooling S/C water by RHR heat exchanger (B), and injecting the water to the reactor from LPCI line again (S/C → RHR pump (B) → RHR heat exchanger (B) → LPCI line → the reactor → SRV → S/C). With this configuration the reactor water temperature dropped under 100°C and the reactor was confirmed to be in a cold shutdown state at 07:15 on March 15.

The mentioned above suggests that the water injection to the reactor was successfully continued although the cooling functions of the reactor were temporarily lost, and no fuel damage occurred because the level of iodine-131 was found to be lower than the detection limit in the reactor water sampled in a later investigation.

d. State of the “Confining” function

In accordance with the issuance of “reactor vessel low water level (L-3)” on the automatic shutdown of the reactor, PCIS and SGTS operated correctly to isolate PCV and maintain reactor building subatmospheric pressure. The pressure of PCV has reached a maximum value of about 245 kPa [gage] (S/C side), but not reached its maximum operating pressure of 310 kPa [gage].

No unusual changes in the stack radiation monitor or MP values were observed and no outside radioactive influence was confirmed.

Because there was a rising trend in the pressure of PCV and it could possibly take a long time to recover the heat removal function of the reactor, the line for PCV pressure control vent was configured (so that it could vent by opening the outlet valve in S/C side).

e. State of the spent fuel pool cooling system

The facilities for SFP cooling maintained the water level of SFP at more than its overflow level by FPC, and the water temperature of SFP at around 35°C before the earthquake occurred. However, because of the trip of FPC pumps due to the influence of the quake (“skimmer surge tank water level very low” or “pump suction pressure low”), the inundation of SW pumps (A, B, C) of the Non-safety Service Water System near the water intake outside the building and the submersion of RCW pumps (A, B, C) on the first basement of the seawater heat exchanger building, all of them became inoperable and unable to supply water to FPC heat exchanger, and therefore SFP cooling by FPC became unavailable.

As a result, the water temperature of SFP has reached the maximum of 62°C, but by switching cooling water of FPC heat exchanger from RCW to RHRC for SFP cooling at 16:35 on March 15, the water temperature of SFP dropped to around 35°C at 17:00 on March 16, as low as it was before the earthquake.

The items mentioned above suggest that although SFP temporarily lost its cooling function, it successfully satisfied the operation limits and conditions (SFP water level; close to the overflow level, water temperature; 65°C or less) defined by the Safety Preservation Rules of Nuclear Facilities.

f. State of the “Power Supply” function

The distribution systems were all available just after the automatic shutdown of the reactor, but the emergency power supply (P/C 4C-2, 4D-2) became unavailable because the seawater heat exchanger building was submerged due to the tsunami.

Just after the automatic shutdown of the reactor all of the emergency DGs (A system, B system and HPCS system) were operable, but after the tsunami arrived, because RHRS pumps (A, B, C, D) and EECW pumps (A, B) became unable to start, the emergency DGs (A, B) became also unavailable.

In a later recovery procedure, among the loads of the unavailable emergency power supply (P/C 4D-2), RHRC pump (B) and RHRS pump (D) were allocated power to cool down the reactor and SFP, by the installment of temporary cords and the power supply from the emergency power supply (P/C 3D-2) of the seawater heat exchanger of Unit 3, and to EECW pump (B) by the high voltage power supply vehicle promptly prepared from outside the site (performed on March 14).

By this procedure, the emergency DG (B) was in operable condition, and the emergency power supply (M/C 4D) became ready to receive power from the emergency DG (B) even if the external power supply was lost.

Later, the temporary power supply for the EECW pump (B) was switched from the high voltage power supply vehicle to the emergency power supply (P/C 4D-1) (switched on March 29).

The emergency DG (HPCS) was in operable condition from the time of the automatic shutdown of the reactor, and therefore sufficient emergency power supplies to cool down the reactor and SFP had been secured.

Table Appendix 3-4 Fukushima Daini Nuclear Power Station Unit 4 Situation in Chronological Order After the Occurrence of the Earthquake

Friday, March 11, 2011

- 14:46 Great East Japan Earthquake occurred.
- 14:48 Reactor automatically shut down (“high seismic acceleration trip” was issued), all of the control rods were fully inserted.
- 14:48 One of Tomioka line was shut down (line 2 tripped and continued receiving power from line 1)
- 15:05 Confirmed that the reactor was subcritical.
- 15:22 The first tsunami arrives (tsunami waves were observed intermittently from this time to 17:14).
- 15:33 CWP (C) was stopped by manual operation.
- 15:34 (approx.)
Emergency DGs (A) (B) (H) automatically started. / DG (A) (B) stopped right away due to damage from the tsunami.
- 15:35 CWP (A) (B) automatically stopped.
- 15:36 MSIV was fully opened by manual operation.
- 15:36 RHR (B) was manually started (automatically stopped at 15:41).
- 15:37 RHR (A) was manually started (automatically stopped at 15:38).
- 15:46 Started depressurizing the reactor (SRV was automatically opened) (from this time on, the reactor pressure was controlled by automatic and manual open/close operations).
- 15:50 All of Iwaido line shut down. (Line 2 shut down. Line 1 had been shut down for checkout before the earthquake occurred.)
- 15:54 RCIC was started by manual operation (from this time on, RCIC was started or stopped as required).
- 18:33 Because the start of seawater pump of the facility for heat removal of the reactor was not confirmed, the Station judged that a particular event (loss of the heat removal function of the reactor) defined by Article 10, Paragraph 1 of Special Law for Nuclear Emergency had occurred.
- 19:02 “D/W pressure high” alert was issued.
- 19:14 D/W cooling system was started by manual operation.

Saturday, March 12, 2011

- 00:16 RCIC automatically stopped (due to the drop of the reactor pressure).
- 00:16 Alternative water injection by MUWC was started.
- 06:07 Because the temperature of S/C exceeds 100°C, the Station judged that a particular event (loss of the function to control pressure) as defined by Article 15, Paragraph 1 of Special Law for Nuclear Emergency had occurred.
- 07:23 Cooling down of S/C was performed by use of FCS cooling water (MUWP).
- 07:35 S/C spray was performed by use of MUWC.
- 11:17 Water injection to the reactor was switched from MUWC (alternative injection) to HPCS.
- 11:44 Started configuration of PCV pressure control vent line.
- 11:52 Completed configuration of PCV pressure control vent line.
- 13:38 (approx.)
Received power from one of Iwaido lines (Line 2 was recovered).
- 13:48 Water injection to the reactor by HPCS was stopped (from this time on,

this procedure was done as required).

Sunday, March 13, 2011

05:15 (approx.)

Received power from two lines of Iwaido lines (Line 1 was recovered).

12:43 Drift alert was issued on control rod 10-19.

Monday, March 14, 2011

11:00 EECW (B) was started by manual operation (receiving power from the high voltage power vehicle).

13:07 RHRS (D) was started by manual operation (receiving power via temporary cords from P/C 3D-2).

14:56 RHRC (B) was started by manual operation (the motor was replaced/receiving power via temporary cords from P/C 3D-2)

15:42 RHR (B) was started by manual operation (started S/C cooling mode). Because RHR (B) started, the Station decided to cancel the occurrence of particular event (loss of the heat removal function of the reactor) defined by Article 10, Paragraph 1 of Special Law for Nuclear Emergency.

16:02 RHR (B) S/C spray mode was started.

18:58 RHR (B) started water injection to the reactor in LPCI mode (stopped at 19:20) (from this time on, it was started/stopped as required).

20:19 Drift alert on control rod 10-19 was cleared.

21:07 Drift alert on control rod 10-19 was issued (from this time on, the alert was continuously issued).

22:07 Because radiation dose greater than 5 $\mu\text{Gy/h}$ was detected at MP (No. 1), the Station judged that a particular event (rise of radiation dose at site boundary) as defined by Article 10, Paragraph 1 of Special Law for Nuclear Emergency had occurred. (The rise in radiation dose was estimated to be due to the radioactive release to the air caused by the accident in the Fukushima Daiichi Nuclear Power Station.)

Tuesday, March 15, 2011

00:12 Because a radiation dose greater than 5 $\mu\text{Gy/h}$ was detected at MP (No. 3), the Station judged that a particular event (rise of radiation dose at site boundary) as defined by Article 10, Paragraph 1 of Special Law for Nuclear Emergency had occurred. (The rise in radiation dose was estimated to be due to the radioactive release to the air caused by the accident in Fukushima Daiichi Nuclear Power Station.)

07:15 Because the temperature of S/C dropped under 100°C, the Station decided that it recovered from the particular event (loss of the function to control pressure) defined by Article 15, Paragraph 1 of Special Law for Nuclear Emergency.

07:15 The water temperature of the reactor dropped under 100°C, and the reactor was in cold shutdown.

16:35 Cooling water of FPC heat exchanger was switched (from RCW to RHRC).

Wednesday, March 16, 2011

17:00 SGF water temperature was confirmed as around 35°C (recovered to the water temperature before the earthquake occurred).

Summary of the events on Onagawa Nuclear Power Station

(1) Influence of the earthquake and tsunami

All of Onagawa's reactors from Units 1 to 3 automatically shut down due to the Great East Japan Earthquake. Some damage was found to part of the facilities due to the influence of the quake and tsunami. But there was no influence to the cooling function of the reactors and spent fuel pools because the external power and the emergency power supply were secured and the multiplicity and redundancy of the cooling facilities effectively worked, and all of the units quickly halted and entered a cold shutdown state.

The series of events on Onagawa are shown in Figure Appendix 3-2 with the event tree.

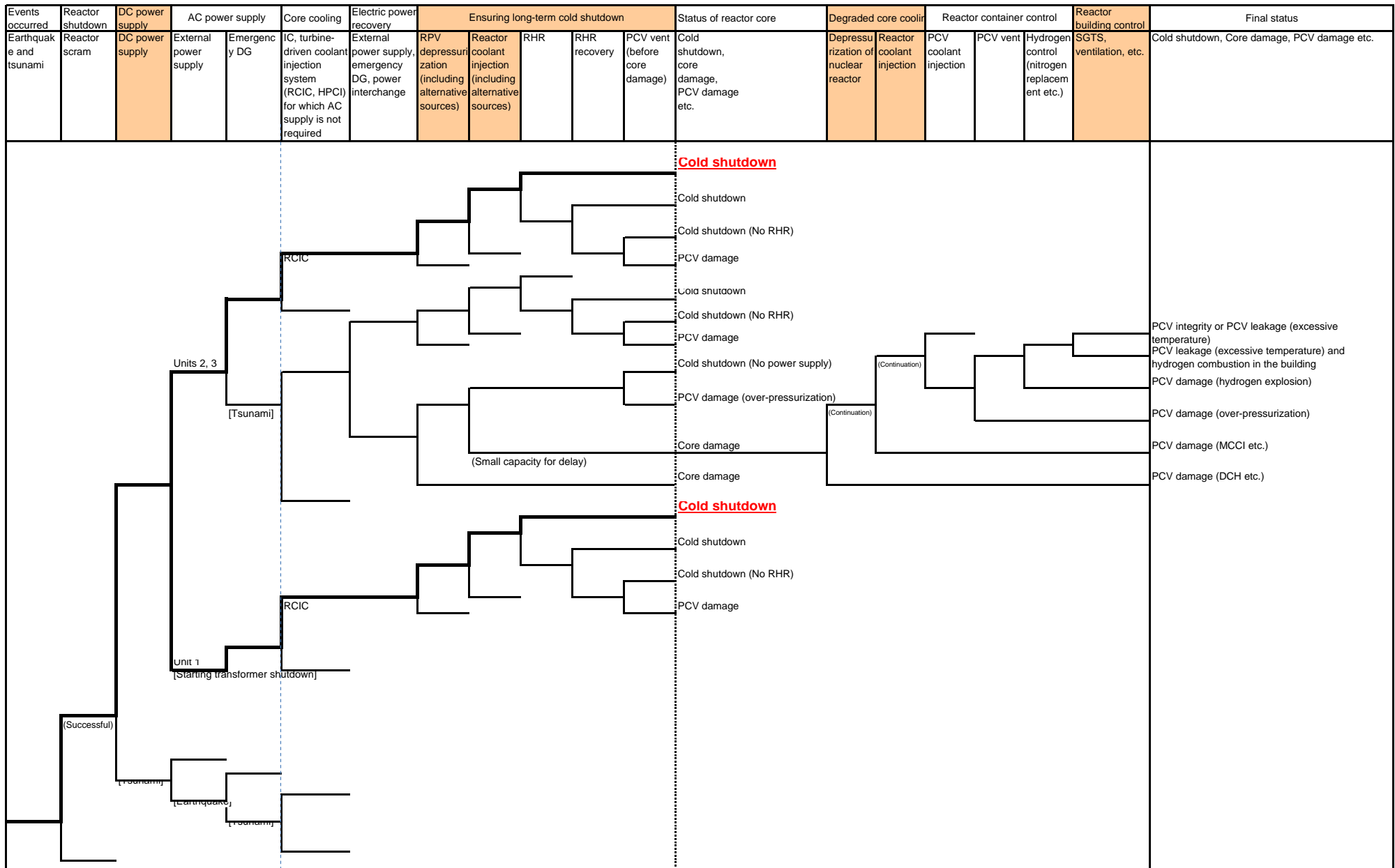

Diagram Appendix 3-2 Onagawa Nuclear Power Station disaster identification events tree

a. Impacts of earthquake

The seismic intensity observed at the site of the Station during the Great East Japan Earthquake was slightly lower than Level 6. Even on a seismograph arranged for safety purposes on the 2nd basement level in the Unit 1 reactor building, 567.5 gal was observed.

The maximum acceleration observed on each level of the Onagawa Units 1 to 3 reactor buildings was almost equivalent, while some levels indicated a maximum acceleration that exceeded the maximum response acceleration for basic design earthquake ground motion S_s based on the Examination Guide for Seismic Design of Nuclear Power Reactor Facilities (as revised in September 2006).

With regard to the response spectrum for site ground recorded in the instrumental earthquake data, every location indicated an almost equivalent response spectrum, while some values exceeded the response spectrum for basic design earthquake ground motion S_s (reflecting the impact of ground status above the seismograph).

As a result of earthquake response analysis based on the current instrumental earthquake data and the evaluations of deformation of earthquake resisting wall in Onagawa Units 1 to 3 reactor buildings as well as the shear force applied on the earthquake resisting wall of each level, maintenance of the functions of reactor buildings was confirmed.

Five circuits supply power to Onagawa Power Station as external power supplies (No. 1 and No. 2 lines of Ojika Main Line [275 kV system], No. 1 and No. 2 lines of the Matsushima Main Line [275 kV system], and Tsukahama Branch Line [66 kV system]). Only the No. 2 line of the Matsushima Main Line was available immediately after the earthquake due to the actuation of the system protection circuit accompanying the accident in the power transmission line in the jurisdiction area of TEPCO. However, the No. 1 line of the Ojika Main Line was recovered at 20:12 on March 12, and then the No. 2 line of the Ojika Main Line at 20:15 on the same day. This was followed by the No. 1 line of the Matsushima Main Line at 10:47 on March 17 and Tsukahama Branch Line on 15:41 on March 26.

b. Impacts of tsunami

The maximum height of the tsunami confirmed on a current meter immediately after the earthquake was O.P. + approx. 13 m* (at 15:29 on March 11) at the maximum. This height did not exceed the altitude of the Onagawa site (O.P.+ approx. 13.8 m*) (before the earthquake: O.P.+ approx. 14.8 m).

While a trace of seawater intrusion was observed due to runoff in part of plant site along the coastline, the waves did not reach the main buildings.

* This value reflects the diastrophism (approx. -1 m: based on the value of top line report) in the vicinity of Onagawa announced by the Geospatial Information Authority of Japan after the earthquake.

(2) Unit 1

a. Station behavior after the earthquake

The earthquake occurred at 14:46 on March 11 during the constant rated thermal power operation, and a seismic acceleration high signal was transmitted and immediately control rods were fully inserted, which resulted in an automatic shutdown of the reactor.

The starting transformers were shut down due to a short-circuit or earth fault inside non-essential metal clad switchgear 6 – 1A that occurred during the earthquake, which led to a temporary loss of non-essential on-site power. While this caused a shutdown of entire pump units in the Condensate and Feed Water System, prompt actuation of RCIC enabled water to be fed to the reactor.

Because the on-site non-essential power was lost temporarily through the starting transformer shutdown, control of the reactor pressure was achieved via SRVs instead of condensers by fully closing MSIVs. After reactor depressurization via SRVs, RCIC was shut down and water was fed to the reactor by using the control rod drive hydraulic control system (hereafter called “CRD”).

The workers cooled the reactor without any problem by RHR and a cold shutdown was achieved at 00:58 on March 12.

b. Status of “Stopping” function

Under the impact of the earthquake, a seismic acceleration high signal (“O.P. 15.00 m vertical direction seismic sensor motion trip”: Set point 100 gal) was transmitted and immediately after that all control rods were fully inserted (at 14:46 on March 11, 2011). Then the reactors were shutdown automatically as designed and subcriticality was confirmed at 15:05 on the same day.

c. Status of “Cooling” function

The starting transformers were shut down due to a short-circuit or earth fault inside non-essential metal clad switchgear 6 – 1A that occurred in the earthquake, which led to temporary loss of non-essential on-site power. While this caused a shutdown of entire pump units in the Condensate and Feed Water System, prompt actuation of RCIC enabled water feed to the reactor.

Because the on-site non-essential power was lost temporarily through the starting transformer shutdown, control of the reactor pressure was achieved via SRVs instead of condensers by fully closing MSIVs.

After reactor depressurization via SRVs, RCIC was shut down and water was fed to the reactor by using the CRD.

The workers cooled the reactor without any problem by RHR and a cold shutdown was achieved at 00:58 on March 12.

d. Status of “Confining” function

PCIS motions accompanying the reactor vessel low water level (L – 3) signal were normal and no abnormal value was observed on the stack monitor, radioactive waste discharge water monitor and MP. There was no radioactive impact on the external environments.

e. Status of spent fuel storage pool

While the earthquake caused FPC shutdown at 14:47 on March 11, it was restarted at 19:30 on the same day upon confirming that there was no abnormality in the equipment. During the shutdown, no significant elevation was seen in the temperature of the spent fuel storage pool. The cause of the FPC shutdown seems to be the actuation of level switch for “skimmer surge tank level low-low” due to the seismic vibration, or the drop of FPC pump suction pressure through a temporary drop of the spent fuel storage pool level due to the seismic vibration.

f. Status of “Power Supply” function

With regard to the power supply, the Station was receiving external power from the No. 2 line of the Matsushima Main Line via starting transformers. However, at 14:55 on March 11, on-site power was lost due to shutdown of the starting transformers. Accordingly, power was supplied to emergency bus by DG (A) and DG (B) based on the design.

The cause of the starting transformer shutdown was the earth fault or short-circuit that occurred inside the non-essential metal clad switchgear 6 – 1A (this resulted in a fire later), which actuated the overcurrent relay of the starting transformers.

Thereafter, the workers confirmed the integrity of the starting transformers based on an appearance inspection and a measurement of the insulation resistance and they restored the starting transformers at 02:05 on March 12. After the starting transformers were restored, power supply of non-essential bus was recovered one by one excluding the non-essential metal clad switchgear 6 – 1A.

The emergency power supply that was needed to cool down the reactor and the spent fuel storage pool until the restoration of the starting transformers was secured.

Table Appendix 3-5: Chronological report for Onagawa Unit 1 after the earthquake

Before the earthquake: Constant rated thermal power operation

March 11, 2011 (Friday)

- 14:46 Great East Japan Earthquake occurred
(Seismic intensity observed on site: Slightly lower than Level 6)
Vertical direction seismic acceleration high; Reactor automatic shutdown
- 14:47 Full insertion of all control rods was confirmed
DGs (A), (B) automatic startup
FPC pump (A) automatic shutdown
- 14:55 DGs (A), (B) load operation started
- 14:59 RCIC manual startup
- 15:00 RHR pump (A) manual startup (For S/P cooling operation)
- 15:01 RHR pump (C) manual startup (For S/P cooling operation)
- 15:05 Reactor subcriticality was confirmed
- 15:05 RHR pump (B) manual startup (For S/P cooling operation)
- 15:12 RHR pump (D) manual startup (For S/P cooling operation)
- 15:55 RHR pump (A), (C) automatic shutdown
- 16:15 RHR pump (A) manual restart (For S/P cooling operation)
- Approx. 17:10
Reactor depressurization started (SRV was used)
- 18:29 RCIC turbine automatic shutdown (via L-8)
- Approx. 19:30
FPC pump (A) manual startup (Fuel pool cooling)
- 20:20 CRD pump (A) manual startup (Water feed to reactor)
- 21:56 RHR pump (A) manual shutdown (SHC preparation [for flushing])
- 23:46 RHR pump (A) manual startup (SHC mode)

March 12, 2011 (Saturday)

- 00:57 Reactor coolant temperature reached 100°C
- 00:58 Reactor status "Cold shutdown"
- 02:05 After the power supply (restoration) of starting transformers, non-essential buses were recovered excluding M/C6-1A which was damaged by fire.

(3) Unit 2

a. Station behavior after the earthquake

The reactor was in start-up operation from 14:00 on March 11 for the 11th periodical inspection. After the earthquake occurred at 14:46 on the same day, a seismic acceleration high signal was transmitted. Then, all control rods were fully inserted immediately and the reactor was shut down.

Because Unit 2 was in the status immediately after starting reactor operation and the status immediately before the earthquake was of subcriticality with the reactor water temperature lower than 100°C, a cold shutdown was implemented at 14:49 on March 11 by operating the reactor mode switch “Shutdown.”

b. Status of “Stopping” function

The reactor was in start-up operation from 14:00 on March 11 for the 11th periodical inspection. After the earthquake occurred at 14:46 on the same day, a seismic acceleration high signal (“R/B bottom horizontal direction high seismic acceleration trip”: set point 200 gal) was transmitted. Then, all control rods were fully inserted immediately and the reactor was automatically shut down as designed. The status of subcriticality was maintained.

c. Status of “Cooling” function

Because Unit 2 was in the status immediately after starting reactor operation for the 11th periodical inspection and the status immediately before the earthquake was of subcriticality with reactor water temperature lower than 100°C, a cold shutdown was implemented at 14:49 on March 11 by operating the reactor mode switch “Shutdown.”

Under the impact of tsunami accompanying the earthquake, the seawater intruded from the cooling water intake canal of the seawater pump area and entered part of the reactor building via an underground trench, which resulted in the functional loss of 2 systems (RCW-B and HPCW). However, because the RCWA system was sound, there was no negative impact on the cooling function of the reactors by RHR.

d. Confining

No abnormal value was observed on the stack monitor, radioactive waste discharge water monitor and MP. There was no radioactive impact on the external environments.

e. Status of spent fuel storage pool

While the earthquake caused FPC shutdown at 14:47 on March 11, it was restarted at 20:29 of the same day upon confirming that there was no abnormality in the equipment. During the shutdown, no significant elevation was seen in the temperature of spent fuel storage pool.

The cause of FPC shutdown seems to be the actuation of level switch for “skimmer surge tank level low” due to the seismic vibration, or the drop of FPC

pump suction pressure through a temporary drop in the spent fuel storage pool level due to the seismic vibration.

Under the impact of tsunami accompanying the earthquake, the seawater intruded from the cooling water intake canal of the seawater pump area and entered part of the reactor building via an underground trench, which resulted in the functional loss of 2 systems (RCW-B and HPCW). However, because the RCW-A system was sound, there was no negative impact on the cooling function of spent fuel storage pool by FPC similar to the case with reactor cooling function by RHR.

f. Status of “Power Supply” function

With regard to the power supply, the Station was receiving external power from the No. 2 line of the Matsushima Main Line via starting transformers and on-site power has been secured constantly.

Under the impact of vibration caused by the earthquake, a generator loss of field signal was transmitted, which resulted in the automatic start-up of DGs (A) / (B) and the high pressure core spray system DG (hereafter called “DG(H)”) followed by a standby status with no load operation. Thereafter, the seawater intruded from the cooling water intake canal of the seawater pump area and entered part of the reactor building via an underground trench, which resulted in the functional loss of 2 systems (RCW-B and HPCW). While this event triggered the automatic shutdown of DG(B) and DG(H), DG(A) was sound and, even if the external power was lost, the emergency power supply that was needed to cool down the reactor and the spent fuel storage pool could be secured.

g. Loss of function in RCW-B, RSW-B and HPCW systems

Under the impact of vibration caused by the earthquake, a generator loss of field signal was transmitted, which resulted in the automatic start-up of DGs (A) / (B) / (H) followed by no load operation. Then, at 15:34, RCW pump (B) shut down automatically and the RCW pump (D) that was started up as a back-up immediately also shut down automatically. This led to the loss of cooling water supply for emergency DG (B) and it was shut down automatically at 15:35. Further at 15:41, HPCW pump shut down automatically, which resulted in the loss of cooling water supply for emergency DG (H) and it was shut down automatically at 15:42.

Inspection of the site revealed that the seawater entered the RCW heat exchanger (B) area, HPCW heat exchanger area and the staircase that accessed the elevator in the uncontrolled area on the 3rd basement level of the reactor building (submergence depth: approx. 2.5 m), and that the RCW pumps (B) / (D) and HPCW pump were submerged and the seawater intruded also into the RCW heat exchanger (A) area (submergence depth: approx. 0.5 m). Therefore, the workers began to drain seawater in the submerged area outside the building at 20:25 by using temporary pumps. The draining process was completed at 10:30 on March 16.

Further, a patrol after the earthquake revealed that the seawater system (hereafter called “RSW”) pump (B) area in the outdoor seawater pump area was submerged and the RSW pumps (B) / (D) installed in this area might have been submerged, too.

We inspected the motors of RCW pumps (B) / (D), RSW pumps (B) / (D) and HPCW pump affected by seawater intrusion (or suspected seawater intrusion) as well as the submerged actuator of the motor operated valves in the factory. As a result of an overhaul inspection, rust was observed on all the components, while the insulation resistance value of some components satisfied the criteria. Accordingly, these pumps were judged as being unable to operate sufficiently to secure the safety of the reactor facility.

This event belongs to a type of event for which reporting is mandatory based on the Rules for the Installation, Operation, etc. of Commercial Power Reactors, Article 19-17, Item 1, and No. 3.

To protect the area against a back wave of a tsunami, level instrumentation for CWP automatic shutdown (hereafter called "this level instrumentation") was installed additionally in the RSW pump (B) section of the seawater pump area (in 2002). However, the Station did not make sufficient consideration in selecting the location for installation or water shielding measures to protect the area from the impacts of the waves that push forward.

Therefore, we estimate the following process occurred: Under the impact of the tsunami accompanying the earthquake, the seawater intruded from the cooling water intake canal and entered the seawater pump area via this level instrumentation box, submerging the RSW pump (B) area and entering part of the reactor building via an underground trench. This event resulted in the functional loss of RCW-B system, RSW-B system and HPCW system.

While this type of level instrumentation is installed also in Units 1 and 3, there was no damage to the RCW system and such like because they are installed in a different area (dust extractor area).

Although there was a trace of seawater intrusion also into the dust extractor area, the cover of this level instrumentation was not detached. Therefore, we estimate that the seawater must have entered from the opening of the dust extractor installed in front of this level instrumentation.

The following countermeasures were implemented to prevent recurrence of the loss of function in RCW (B), RSW (B) and HPCW systems:

- This level instrumentation was detached and water shielding work was carried out on its opening.
The location to install this level instrumentation is to be changed to an area less susceptible to seawater intrusion.
- Repair work was conducted on the section from the seawater pump area to the pipe penetration to trench and the cable tray penetration.
- As mid-term and long-term countermeasures, we will improve the water sealing performance of the building doors and the installation of tide embankment and tide wall as part of countermeasures to prevent submergence by tsunami. These measures are implemented within the framework of emergency safety countermeasures for the Onagawa Nuclear Power Station complied based on the instructions of the Minister of Economy, Trade and Industry dated March 30, 2011, "On the Implementation of Emergency Safety Measures at Other Power Stations drawn from the 2011 Accident at Fukushima Daiichi and Daini Nuclear Power Stations (Minister's Instructions)"

With regard to the submerged pump motors and motor operated valve actuators, repair work (cleaning, maintenance etc.) was conducted based on the result of an overhaul inspection.

Table Appendix 3-6: Chronological report for Onagawa Unit 2 after the earthquake

Before the earthquake: "start-up" immediately before the earthquake for the 11th periodical inspection

March 11, 2011 (Friday)

14:00 Reactor mode switch "Refueling" → "Start-up" (Reactor status "Start-up")
Control rod withdrawal started

14:46 Great East Japan Earthquake occurred
(Seismic intensity observed on site: Slightly lower than Level 6)
R/B bottom horizontal direction seismic acceleration high; Reactor automatic shutdown

14:47 Full insertion of all control rods was confirmed
Emergency DGs (A), (B) and (H) automatic startup
* Based on generator loss of field signal
FPC pump (B) automatic shutdown

14:49 Reactor mode switch "Start-up" → "Shutdown"
(Reactor status "Cold shutdown")

15:34 RCW pumps (B) and (D) automatic shutdown (due to pump submergence)

15:35 Emergency DG (B) automatic shutdown (due to RCWs (B) and (D) shutdown)

15:41 HPCW pump automatic shutdown (due to pump submergence)

15:42 Emergency DG (H) automatic shutdown (due to HPCW shutdown)

20:29 FPC pump (A) manual startup (Fuel pool cooling)

March 12, 2011 (Saturday)

12:12 RHR pump (A) manual startup (SHC mode)

Table Appendix 3-7: Chronological report on RCW-B system, RSW-B system and HPCW for Onagawa Unit 2

March 11, 2011 (Friday)

- 14:00 Reactor start-up
- 14:46 Great East Japan Earthquake occurred (seismic intensity observed on site: Slightly lower than Level 6)
Reactor automatic shutdown
Emergency DGs (A), (B), (H) automatic startup (no-load operation)
- 14:49 Issue of great tsunami alarm
- Approx. 15:21 The first tsunami arrives (an operator confirms the time visually)
- 15:34 RCW pump (B) automatic shutdown
RCW pump (D) automatic shutdown (shutdown immediately after started up as back-up)
- 15:35 Emergency DG (B) shut down automatically by “RCW differential pressure low” signal
- 15:41 HPCW pump automatic shutdown
- 15:42 Emergency DG (H) shut down automatically by “HPCW differential pressure low” signal
- Approx. 16:00 The operator who inspected the reactor building confirmed intrusion of water in the RCW heat exchanger (B) area on the lowest basement level, stairs (2 points) on the 3rd basement level to access the HPCW heat exchanger area and in the RCW heat exchanger (A) area (uncontrolled area).
- 16:01 RSW pump (B) manual shutdown (due to submergence of RCW B system)
- 16:06 HPSW pump manual shutdown (due to submergence of HPCW system)
- Approx. 20:12 As a result of analysis of the intruded water, no radioactivity was detected and the water was found as the seawater.
- 20:25 Temporary pumps were installed and work to drain the seawater that flew into the 3rd basement level of the reactor building (uncontrolled area) to outside the building was started.

March 16, 2011

- 10:30 Draining of the seawater from the building was completed.

(4) Unit 3

a. Station behavior after the earthquake

Upon the earthquake that occurred at 14:46 on March 11 during the constant rated thermal power operation, the seismic acceleration high signal was transmitted and all control rods were fully inserted, which resulted in the automatic shutdown of the reactor.

Under the impact of the tsunami, a “seawater pump area level low” signal was transmitted, which resulted in the shutdown of CWP. At the same time, submergence under the seawater that entered the seawater pump area of the heat exchanger building caused the shutdown of the turbine auxiliary sea water system (hereafter called “TSW”) pumps. Due to the loss of cooling water supply caused in this event, all the reactor feed water pumps were manually shut down. Then, RCIC was started up to feed water to the reactor, and reactor pressure control was carried out by SRVs upon fully closing MSIVs, because the condensation of main steam by using condenser failed.

After the shutdown of RCIC accompanying the reactor depressurization, water was supplied to the reactor by CRD. Thereafter, the workers cooled the reactor by RHR without any problem and a cold shutdown of the unit was achieved at 01:17 on March 12.

b. Status of “Stopping” function

Upon the earthquake that occurred at 14:46 on March 11 during the constant rated thermal power operation, the seismic acceleration high signal (“R/B bottom vertical direction high seismic acceleration trip”: Setpoint 100 gal) was transmitted and all control rods were fully inserted, which resulted in the automatic shutdown of the reactor as designed. Status of subcriticality was confirmed at 14:57 on the same day.

c. Status of “Cooling” function

Under the impact of a back wave of the tsunami, a “seawater pump area level low” signal was transmitted, which resulted in the shutdown of CWP as designed. At the same time, submergence under the seawater that entered the seawater pump area of the heat exchanger building due to the tsunami caused the shutdown of TSW pumps. Due to the loss of cooling water supply caused by this event, all the reactor feed water pumps were manually shut down. Then, RCIC was started up to feed water to the reactor, and reactor pressure control was carried out by SRVs upon fully closing MSIVs, because the condensation of main steam by using condenser failed.

To feed water to the reactor after the shutdown of RCIC accompanying the reactor depressurization, multiple options could be considered; i.e. the ECCS by using suppression pool water as water source, the MUWC by using condensate storage tank as water source and so on. We selected MUWC using condensate storage tank as water source to feed water to the reactor with giving consideration to the decrease of decay heat through plant shutdown and the maintenance of reactor water quality.

The workers cooled the reactor without any problem by RHR and a cold shutdown was achieved at 01:17 on March 12.

d. Status of “Confining” function

No abnormal value was observed on the stack monitor, radioactive waste discharge water monitor and MP. There was no radioactive impact on the external environments.

e. Status of spent fuel storage pool

While the earthquake caused FPC shutdown at 14:47 on March 11, it was restarted at 15:23 on the same day upon confirming that there was no abnormality in the equipment. During the shutdown, no significant elevation was seen in the temperature of spent fuel storage pool.

The cause of FPC shutdown seems to be the actuation of level switch for “skimmer surge tank level low” due to the seismic vibration, or the drop in FPC pump suction pressure through a temporary drop in the spent fuel storage pool level due to the seismic vibration.

f. Status of “Power Supply” function

With regard to the power supply, the Station was receiving external power from the No. 2 line of the Matsushima Main Line via starting transformer, and on-site power has been secured constantly. Further, all of the emergency DGs were sound and, even if the external power was lost, the emergency power supply that was needed to cool down the reactor and the spent fuel storage pool could be secured.

Table Appendix 3-8: Chronological report for Onagawa Unit 3 after the earthquake

Before the earthquake: constant rated thermal power operation

March 11, 2011 (Friday)

- 14:46 Great East Japan Earthquake occurred
(Seismic intensity observed on site: Slightly lower than Level 6)
R/B bottom vertical direction seismic acceleration high; Reactor automatic shutdown
- 14:47 Full insertion of all control rods was confirmed
- 14:57 Reactor subcriticality was confirmed
- 15:26 RCIC manual startup (Water feed to reactor)
- 15:28 RSW pump (D) manual startup (S/P cooling operation)
- 15:30 RCW pump (B) manual startup (S/P cooling operation)
- 15:30 RHR (B) manual startup (S/P cooling operation)
- 15:43 RSW pump (C) manual startup (S/P cooling operation)
- 15:44 RHR (A) manual startup (S/P cooling operation)
- 15:45 RCW pump (A) manual startup (S/P cooling operation)
- 16:40 Reactor depressurization started (by using SRV)
RCIC turbine shutdown (by L-8)
- 16:57 RCIC manual startup (Water feed to reactor)
- 21:44 RHR pump (A) manual shutdown (SHC preparation)
- 21:45 RCIC turbine manual shutdown
- 21:54 Water feeding by MUWC (Water feed to reactor)
- 23:51 RHR pump (A) manual startup (SHC mode)

March 12, 2011 (Saturday)

- 01:17 Reactor coolant temperature lower than 100°C (Reactor status "Cold shutdown")

Summary of Events in Tokai Daini Nuclear Power Station

(1) Impacts of earthquake and tsunami

The earthquake struck the Tokai Daini Nuclear Power Station during its constant rated thermal power operation. At 14:48 on March 11, the reactor shut down automatically due to a turbine trip caused by a large vibration of the turbine bearing under the impact of the earthquake. Immediately after the earthquake, all three circuits for external power were lost. However, the power supply for emergency components was secured because of the start-up of 3 emergency DG units. Immediately after the automatic shutdown of the reactor, its water level was kept normal by RCIC and HPCS and the reactor pressure was controlled by SRV. Decay heat after the reactor shutdown was removed through cooling of RHR suppression pool.

Thereafter, under the impact of tsunami, seawater pumps for cooling Emergency DG2C were automatically shut down, which resulted in the Emergency DG2C becoming unusable. Nevertheless, emergency power could be secured by operating the remaining 2 emergency DGs without causing any disturbance to the cooling function for the reactor and SFP. At 00:40 on March 15, the cold shutdown of the reactor was achieved.

The course of events in the Tokai Daini Nuclear Power Station is illustrated as an event tree in Figure Appendix 3-3.

Events occurred	Reactor shutdown	Direct power supply	AC supply		Core cooling	Electric power recovery	Ensuring long-term cold shutdown					Status of reactor core
			External power supply	Emergency DG			RPV depressurization (including alternative sources)	Reactor coolant injection (including alternative sources)	RHR	RHR recovery	PCV vent (before core damage)	
Earthquake and tsunami	Reactor scram	DC power supply	External power supply	Emergency DG	High pressure core cooling system (RCIC, HPCS)	External power supply, emergency DG, power interchange	RPV depressurization (including alternative sources)	Reactor coolant injection (including alternative sources)	RHR	RHR recovery	PCV vent (before core damage)	Cold shutdown, core damage, PCV damage etc.
												<p>Cold shutdown</p> <p>Cold shutdown</p> <p>Cold shutdown (No RHR)</p> <p>PCV damage (over-</p>

Figure Appendix 1-3 Toukai Daini Nuclear Power Station disaster identification events tree

a. Impacts of earthquake

Seismic intensity observed on site (Tokai in Tokai Village) was slightly lower than Level 6, and the maximum accelerations recorded on a seismograph arranged on the 2nd basement level of the reactor building was 214 gal in the North-South direction, 225 gal in the East-West direction and 189 gal in the vertical direction.

The Station confirmed that the maximum acceleration observed on each level of the reactor building was maintained below the maximum acceleration for the basic design earthquake ground motion S_s based on the Examination Guide for Seismic Design of Nuclear Power Reactor Facilities (as revised in September 2006). With regard to the response spectrum for the instrumental earthquake data, while some records indicated that they locally exceeded the response spectrum for the basic design earthquake ground motion S_s , the analysis result revealed that the data maintained the level below the response spectrum for the basic design earthquake ground motion S_s in most frequency bands including those where natural frequencies for the important components in terms of seismic design centered upon.

Immediately after the earthquake, 3 external power circuits (275 kV systems and 154 kV system) were lost. Thereafter, 154 kV system was restored on March 13 and one circuit of 275 kV systems was restored on March 17. Another 275 kV system was recovered on April 27. With this, all circuits of the external power were recovered.

b. Impacts of tsunami

The status of the flood caused by the tsunami during the earthquake was inspected at the intake area. As a result, the Station confirmed that, at around 15:35, the intake area located at altitude* +3.3 m (approx.) (altitude before the earthquake) suffered flooding with approx. 1 m depth (depth of submergence is estimated based on images from monitor cameras in every case).

Further, the Station confirmed that the submergence of approx. 2 m occurred in the intake area also at around 16:51. This was followed by submergence that occurred several times (depth \leq 1 m) in the intake area.

Based on the results of on-site investigation including the investigation of flood traces, the height of tsunami in the Tokai Daini Nuclear Power Station is estimated as altitude* +5.3 m (approx.) (altitude after the diastrophism investigation). Because this height did not exceed the height of the Tokai Daini Nuclear Power Station site (altitude* +8.0 m (altitude before the earthquake)), the tsunami did not reach the main buildings of the Station.

The tsunami reached the point around the seawater pump area in the plant site along the coastline (altitude* +3.3 m (altitude before the earthquake)). While there was no water intrusion from above the North-South side walls of the seawater pump area because they had altitude * +6.1 m height (altitude before the earthquake) as a countermeasure against tsunami, some water intrusion from penetration hole was observed in the north pump area, since the area was under construction for sealing the side wall penetrations.

* This altitude is based on Tokyo Peil (T.P.) (i.e., it does not reflect the ground subsidence caused by diastrophism).

(2) Status of “Stopping” function

Under the impact of the earthquake, vibration of the turbine bearing increased and a “turbine bearing vibration high” signal was transmitted, which resulted in a turbine trip and, as a consequence, an automatic shutdown of the reactor.

All control rods were fully inserted normally (at 14:48 on March 11) and the reactor core was maintained in a subcriticality status.

(3) Status of “Power Supply” function

While 3 external power circuits were lost upon occurrence of the earthquake, 3 emergency DG units (2C, 2D and HPCS) started up automatically and the power supply to the emergency power bus was started.

The Emergency DG seawater pump (2C) shut down due to the intrusion of seawater into the north pump tank under the impact of tsunami. This event caused the Emergency DG2C to become unusable, which led to the power loss of the Emergency AC Power Bus 2C.

Because the power on the Emergency AC Power Bus 2D and HPCS Bus could be ensured continuously, power supply to emergency components could be maintained.

With regard to emergency DC power, the workers supplied power to the batteries and to the DC power load from the emergency power bus. While the Emergency AC Power Bus 2C had lost power, the DC power supply connected to this bus was switched to the power supply from the sound emergency AD power bus and the power was fed to the batteries without any problem. Therefore, the site did not lose DC power.

(4) Status of “Cooling” function

Due to the water level fluctuation immediately after the reactor shutdown, an automatic start-up of HPCS and RCIC as a part of ECCS occurred. This secured the function to inject coolant to the reactor in a high pressure status, which helped keep a normal water level in the reactor. Thereafter, the reactor water level was maintained by RCIC (at first CST, and then the suppression pool was used as the water source) and the pressure control for the reactor was implemented by SRVs.

To remove decay heat after the reactor scram, RHR was started up manually and the cooling of suppression pool was started.

Excluding the emergency diesel generator seawater pump (2C) installed in the north pump tank, no negative impact on the function was observed on the RHR seawater pumps (A) / (C) and the seawater pumps (A) / (C), although they were submerged up to the bottom level of the generators.

(5) Status of “Confining” function

The water level fluctuation (level drop) that occurred immediately after the reactor scram caused normal actuation of the containment isolation system, leading to isolation of reactor containment.

Similarly, the water level fluctuation (level drop) that occurred immediately after the reactor scram caused automatic isolation of the reactor building and the normal

switching of the reactor building ventilation system from normal ventilation system to the Standby Gas Treatment System (SGTS).

(6) Status of spent fuel pool cooling

Sloshing of water by the earthquake actuated an alarm for the spent fuel pool level ("FUEL POOL LEVEL HI/LO"). At the same time, the water level decreased by approx. 20 cm from the normal level, because flooding from the pool occurred.

To address this event, water was filled in the spent fuel pool by using CST water.

While the water level dropped, spent fuel stored in the spent fuel pool were sufficiently covered by water continuously (fuel top + approx. 7 m).

While the Fuel Pool Cooling System was shut down due to loss of external power, cooling was resumed by using a power supply from the sound Emergency DG2D.

(7) Cause of seawater intrusion into north pump tank under the impact of tsunami and countermeasures

With regard to the emergency seawater pump tanks, separation walls of altitude* +6.1 m height (altitude before the earthquake) had been installed to protect the area against tsunami of altitude* +5.7 m height (approx.) (altitude before the earthquake). At this time on March 11, construction work for water sealing the pump tanks was going on.

The height of the tsunami observed in the current disaster was altitude* + approx. 4.8 to 5.3 m (altitude after the diastrophism investigation). While this height did not exceed the height of the separation walls of altitude* +6.1 m (altitude before the earthquake), seawater entered the north pump tank from the following 2 points during the water sealing work.

The water sealing work on the south pump tank had been completed then.

- i) Opening between the north pump tank and ASW strainer area (discharge channel)
- ii) Unsealed structure of the cable pit

Therefore, these 2 points were blocked by placing concrete over them.

* This altitude is based on Tokyo Peil (T.P.).

Table Appendix 3-9: Chronological report for Tokai Daini Nuclear Power Station after the earthquake

Before the earthquake: Constant rated thermal power operation

March 11, 2011 (Friday)

- 14:46 Great East Japan Earthquake occurred (Seismic intensity observed on site: Slightly lower than Level 6)
- 14:48 The reactor shut down automatically with turbine stop valve closure due to automatic shutdown of turbines caused by large vibration of turbine bearing.
- 14:48 Full insertion of all control rods was confirmed
- 14:48 PCIS actuation
- 14:48 HPCS automatic startup
- 14:49 RCIC automatic startup
- 14:52 HPCS injection valve automatic closure and RCIC automatic shutdown (by Reactor Water Level High (L-8))
- 15:01 Suppression pool cooling operation started by Residual Heat Removal A System (Manual)
- 15:10 Reactor subcriticality was confirmed
- 15:36 RCIC manual startup (Water feed to reactor)
- 16:40 Suppression pool cooling operation started by Residual Heat Removal B System (Manual)
- 19:01 Emergency diesel generator seawater pump 2C automatic shutdown
- 19:21 Suppression pool cooling operation by Residual Heat Removal A System shut down (Manual)
- 19:22 Emergency DG2C manual shutdown
- 21:52 Reactor depressurization started (by using SRV intermittently)

March 12, 2011 (Saturday)

- 11:37 Control of reactor water level was switched from RCIC to HPCS
- 13:11 RCIC manual shutdown (as a result of reactor pressure drop)

March 13, 2011 (Sunday)

- 19:41 Power supply from external back-up power (154 kV) to the on-site power supplies one after another

March 14, 2011 (Monday)

- 23:43 Shutdown cooling mode operation started by Residual Heat Removal A System

March 15, 2011 (Tuesday)

- 00:40 Reactor coolant temperature lower than 100°C (Reactor status "Cold shutdown")

March 17, 2011 (Thursday)

- 15:47 Tokai Nuclear Power Station Line No. 1 (275 kV) was charged

March 22, 2011 (Tuesday)

- 22:10 Emergency DG2C standby (Inspection of Sea Water Pump 2C completed)

April 27, 2011 (Wednesday)

- 16:29 Tokai Nuclear Power Station Line No. 2 (275 kV) was charged

Appendix 4 Agenda for Future Review

In this report, we summarized the results of investigating the initial phase of the accident at the Fukushima Daiichi Nuclear Power Station, the analysis of the accident causes and the countermeasures considered effective based on the lessons we learned from the accident.

However, because there are many aspects that require further collection and analysis of information regarding the international approaches for improving safety, further approaches to control the impacts of this accident, and consultations with national and local governments, we still have a series of agenda that are not included in the scope of the current review. Therefore, we would like to identify the items requiring examination in future by the nuclear industry community so as to further improve safety in nuclear power plants.

In the current review, we did not cover the analysis of the root cause of the accident including the organization factors, because it was impossible for TEPCO workers in charge of each area to share their time for interviews that may last a long time due to their intensive efforts and the time pressure they are under in controlling this accident. If additional information that is not accessible to us at this moment becomes unveiled in future, we want to proceed with our examination by integrating the new information.

Agenda for future review are shown below:

- Countermeasure against the fire associated with earthquake
Industry-wide examinations have been made and various countermeasures have been implemented to secure plant-specific safety against fires so far. However, we want to proceed with our examination on items, if any, that need to be addressed based on the findings from the current earthquake.
- Countermeasure against the flood associated with earthquake
With regard to the flood, assessments of impacts on safety-related components have been made and protection measures have been examined since the the Chuetsu Offshore Earthquake in Niigata Prefecture. However, we want to proceed with our examination on items, if any, that need to be addressed based on the findings from the current earthquake.
- Countermeasure against the facility destruction by terrorist attacks
Since 9/11, 2001, the United States has promoted diverse commitments to prevent terrorist attacks on nuclear power plants. It is necessary for Japan to promote examinations on how to secure functions of nuclear power plants (“stopping,” “cooling” and “confining”) to address the large-scale destruction of facilities by terrorist attacks.
- Reinforcement of disaster preparedness measures
In the current accident at the Fukushima Daiichi Nuclear Power Station, the extent of discharge and diffusion of radioactive materials exceeded the scope of impacts estimated in the conventional disaster preparedness plans. A radical review of the disaster preparedness plans is needed while reflecting in them the

findings of the current disaster. Elaborate countermeasures should be sought from the standpoint of nuclear power plant owners while reflecting them in the contents to be reviewed.

- **Reconsideration of approaches for safety culture**
Industry-wide serious reconsideration is needed on the cause of the Station's inability to prevent this accident including the aspects such as "Why was preventive measure not implemented in anticipation of tsunami in the scale far beyond the estimation?" and "Why was countermeasure not taken in anticipation of long time power loss?" The results of the reconsideration should be reflected in the approaches to nurture the safety culture with the purpose to prevent recurrence of the accident.
- **Approaches to PSA**
While industry-wide arguments have been accumulated on the seismic probabilistic safety assessment (PSA) so far, the current accident calls an enhanced attention to the importance of PSA-based approaches to natural phenomena. Accelerated review and establishment of various types of PSA evaluation methods are necessary to implement appropriate evaluation of each nuclear power plant facility. Further, identification of the points to be reinforced and the countermeasures to address the points are desired.
- **Approaches to human resources development**
It is impossible for the industry to learn lessons directly from this accident as to "what kind of strategy should be in place to develop appropriate human resources." From the standpoints of improving the safety of nuclear power plants and the nuclear disaster preparedness, it is necessary for the industry to examine possible policies for development of human resources in future so as to establish a system to enable a systematic human resource recruitment and education with a wide outreach. Further, at least education to hand down the lessons from this accident and the learning of the new countermeasures are essential and it is imperative to establish a mechanism to keep this cycle running on a continuous basis.
- **Approaches to the agenda related to multiple-reactor siting**
At present, the scope of impact and problems associated with specific measures against the accident in a multiple-reactor site are yet to be identified except the hydrogen explosion that occurred in Unit 4 caused by the hydrogen that was generated in Unit 3 and migrated to Unit 4 via an exhaust line. Based on the experience of the explosion in Unit 4, we plan to screen out similar types of systems from the standpoint of ensuring independency as one of the lessons learned from this accident.
If further information concerning the multiple-reactor siting is obtained in the process of the accident investigation in future, we want to proceed with our approach to extract the lessons on the multiple-reactor siting and examination on specific countermeasures.
We consider that the manpower deployment should be reviewed depending on the necessity through the training based on the assumption of simultaneous accidents in multiple units.

- Approaches to the findings related to accident handling
While many kinds of work are going on currently to terminate the accident, we have learned various lessons from each of them. For instance, with regard to the handling of retained water, there are various lessons in a series of processes including the generation of polluted water, prevention of its leakage to the environment, management and disposal. Approaches to issues related to the accident handling should be continued on a mid-term and long-term basis.
- Containment filter vent
Based on the experience of this accident, necessity and importance of containment ventilation are recognized to prevent damage of the containment through pressurization. However, with regard to the containment ventilation particularly under severe accident conditions, the impact of discharged radioactive materials on the surrounding environments is a concern.
To address this issue, some overseas countries (in Europe) install containment filter vents to suppress any discharge of a large amount of radioactive materials to the atmosphere as one of the countermeasures for severe accidents. This practice has yet to be introduced to Japan.
In the current accident, the discharge route of radioactive materials has not been identified yet. Therefore, it is unknown at present whether or not the installation of a containment filter vent could have prevented discharge of the large amount of radioactive materials. Nevertheless, the appropriateness of installing a containment filter vent should be examined as part of a countermeasure to mitigate impacts on the surrounding environment.

Appendix 5 Comparison with Government Report and NRC Task Team Report

In conducting the current review, we, as the industry, extracted the items that need to be addressed from the wide range of issues to prevent recurrence of the accident in terms of both direct factors and indirect factors based on the clearly defined facts at this stage without eliminating guesswork as much as possible. Further, we manifested our continued commitment to the review by identifying the agenda requiring further examination in future besides the lessons perceived from the course of the accident at the Fukushima Daiichi Nuclear Power Station.

Meanwhile, in the report of the Japanese Government to the IAEA Ministerial Conference on Nuclear Safety held in June 2011, 28 lessons were compiled that require commitments by workers, national government and local authorities. To clarify the industry's attitude to these 28 items, a comparison between these items and the lessons compiled by the industry is indicated in Appendix 3.1.

Further, in "Recommendation for Enhancing Reactor Safety in the 21st Century" compiled by the US NRC task force as a report of investigation and review on the accident at the Fukushima Daiichi Nuclear Power Station, 12 recommendations are listed including the requests to regulatory bodies. We also made a comparison with these recommendations and listed the comparison result in Appendix 3.2 to identify any additional issues to be addressed.

Appendix-5.1 Comparison with the training of 28 items of Government Report to IAEA and the measure against this report on the accident of Fukushima Daiichi Nuclear Power Station

Group name	Items	Contents	Additional requirements in attachment data	Comparison with the measures of this report
Measure to prevent a severe accident	(1) Measure to mitigate an earthquake and tsunami	<p>This earthquake was a very large-scale earthquake due to the interlocking of multiple epicenters. As a result, in the Fukushima Daiichi Nuclear Power Station, the acceleration response spectrum of the earthquake motion observed on the reactor building basic board exceeded some periodic belts as compared with the acceleration response spectrum of the basic earthquake ground motion of its design. Due to the earthquake, damage was observed in the external power supply.</p> <p>Although the major damage to the reactor facilities caused by the earthquake has not been confirmed in terms of important safety-related system and equipment. The detailed situation is still not known and further investigation about it is required.</p> <p>The height of the tsunami that struck the Fukushima Daiichi Nuclear Power Station was 14 to 15 m, exceeding well over the assumed height of the construction permit design and valuation. As a result of this tsunami there was major damage to seawater pumps and such like, making it impossible for Station to ensure and reserve an emergency diesel power supply and reactor cooling function. In the manual, the intrusion of a tsunami was not assumed but only the measures against an undertow were defined. Thus, the Station failed to assume the frequency of the tsunami occurrence and its height sufficiently, the measures were not good enough for handling an extensive tsunami.</p> <p>From the viewpoint of design, in the seismic design of the nuclear power plant the time range of an active fault is considered to be between 120,000 and 130,000 years (in the old guidelines it is 50,000 years). The recurrence cycle of a big earthquake and residual risk should be considered. On the other hand, the Station is designed to handle tsunami based on past traditions and clear traces of tsunami. To attain safety objectives, the Station made no efforts that considered an appropriate recurrence cycle.</p> <p>Due to this, while assuming an earthquake would occur, multiple epicenters interlocking should be considered and at the same time the external power supply's resistance to disasters should be improved. The suitable generating frequency of the tsunami in consideration of a sufficient recurrence cycle for achieving safety and sufficient height are assumed from the viewpoint of preventing a severe accident. For the tsunami having an appropriate height, safety design of construction which prevents water from flooding the site should be executed with consideration given to the destructive force of that tsunami. From the viewpoint of defense in depth, risks should be fully recognized by observing the exceeded tsunami's coverage on site as against the planned design for a tsunami. Countermeasures should be taken so that important safety functions can be preserved even with consideration given to the site flood or destruction force of waves.</p>	<p>From the viewpoint of improving the Station's reliability to ensure an external power supply, countermeasures such as connecting each unit</p>	<p>The following evaluation conditions to evaluate an earthquake and tsunami are added based on the knowledge acquired from this data.</p> <ul style="list-style-type: none"> In the present view, Ss measures for basic design earthquake ground motion are considered to be almost satisfactory. But in order to be assured of further safety, interlocking of two or more epicenters should be considered. When evaluating the height of tsunami caused by an earthquake, consideration should be given to the interlocking of multiple epicenters as a wave source at a plate barrier and, the necessity of assuming the epicenter fault has a sliding quantity on a large scale should be examined. <p>Related to the external power supply, on the basis of NISA direction document [About reliability reservation of the external power supply of a nuclear power plant and a reprocessing facility], the measures (circuit connection, strengthening of a steel tower, measure against inundation of switchyard) for reliability reservation is performed.</p> <p>The assumed tsunami height is estimated and, prevention measures should be taken to prevent the tsunami from entering the site. Moreover, the following multi-level countermeasures should be performed to ensure functions of safety equipment.</p> <p>Countermeasures should be used to prevent the tsunami from entering the site. Examples are as follows.</p> <ul style="list-style-type: none"> Care should be taken for arranging the safety-related power supply system. While preparing for a flood from a tsunami, a coastal levee (storm surge barrier) or breakwater should be installed, or from the viewpoint of multilevel security, a protection barrier should be installed for important systems. There should be protection against tsunami for items such as tanks which may become flotsam and interfere with emergency responses (protective barrier etc.). Heavy industrial machines should be used to remove flotsam. <p>Moreover, countermeasures should be taken to prevent seawater from entering the building. Illustrative examples are as follows.</p> <ul style="list-style-type: none"> For tsunamis which exceed the site height, tsunami preventive measures such as improvement of the external gate of the building or the sealing of air supply opening and penetration should be executed according to the inundation height. For tsunamis which exceed the site height, safety-related facilities should be protected from inundation by countermeasures for improving watertightness of the ground stage gate and the gate which passes through the main ground stage. Thus, the impact of inundation should be minimized. To promptly restore the station, portable water discharging pumps should be deployed in the building for discharging the seawater that has entered. Regarding the impact of the wave power of a tsunami, attention should be paid to places where a direct impact of tsunami is observed such as external gates facing the sea. <p>Moreover, tsunami countermeasures should be taken against seawater pumps.</p> <ul style="list-style-type: none"> Items mentioned in this report is 4.6 Preparation against earthquake and tsunami Countermeasure Examples Preparation against earthquake and tsunami (1) to (9) <p>From the viewpoint of ensuring a power supply, an external power supply should be assured, and when it is not possible, equipment should be installed for supplying power from emergency DG.</p>
	(2) Assurance of power supply	<p>The major factor of this accident is that the required power supply was not assured. This cause indicated that there was an insufficient variety of power supplies to overcome the Station's vulnerability to a common cause failure due to external events.</p>	<p>From the viewpoint of ensuring a power supply, an external power supply should be assured, and when it is not possible, equipment should be installed for supplying power from emergency DG.</p>	

Group name	Items	Contents	Additional requirements in attachment data	Comparison with the measures of this report
		<p>Setting up a power board or such like was not sufficient to withstand a severe environment. Moreover, the battery life ended before the AC power supply came back; this indicates that the objective of having a battery is not clear. The Station did not know the time needed for the external power supply to be restored.</p> <p>For this, a power supply should be able to be assured for a long time in a severe situation by installing various emergency power supply such as air cooled diesel generators and gas turbine generators, diversifying types of power supply by deploying a power supply vehicle, distributing a switchboard having high environmental tolerance, or installing a battery charging generator.</p>	<p>and all power lines, Strengthening a transmission tower (power lines) and avoiding the switchyard from being soaked were indicated.</p> <ul style="list-style-type: none"> Entrepreneurs were asked about the measure required for the power supply reservation in an emergency. These measures include ensurance of high capacity of a rechargeable battery or battery charging from the existing backup power supply, safety-related equipment or power supply boards having a higher evaluation so that all functions will not be lost in a flood and decentralized geometry such as installing on high ground, earthquake-proof tempering of switchyard facilities, maintenance of the system to procure fuel oil, which is required for securing emergency power supply. <p>[September 11, 2011, attached Government Report] As a future measure, rechargeable battery having a high capacity or earthquake-proof strengthening of the fuel tank of emergency power supply, etc. are planned.</p>	<p>However, these preparations did not work this time. Therefore, the reliability of an external power supply should be improved.</p> <p>(1) External power supply is based on the NISA directions [About reliability reservation of the external power supply of a nuclear power plant and a reprocessing facility]. It corresponds to the measures (circuit connection, strengthening of a steel tower, measure against inundation of switchyard) to ensure a reliable power supply. The following details are based on the assumption that emergency DG functioning has failed.</p> <p>(2) As a backup power supply of an emergency DG, various types of power supplies should be secured by deploying a power supply vehicle or high capacity power supply (including necessary fuel). Regarding power panels, preparations must be made for a tsunami by taking inundation countermeasures. Moreover, the power supply vehicle is installed on high ground which is not affected by a tsunami. Separately, measures for the loss of DC power supply must be given .</p> <p>(3) A rechargeable battery ensures a power route from a power supply vehicle and it must have inundation measures to combat a tsunami.</p> <p>Secure power supply reservation is achieved by these multilevel measures.</p> <ul style="list-style-type: none"> Items mentioned in this report 4.7.1 Station blackout and loss of DC power supply Counter-measure examples Preparation of power supply (1) to (6)
(3) Assurance of secured cooling function of reactor and containment		<p>In this accident, there was a functional loss of a seawater pump, which resulted the loss of the ultimate heat escaping place. Although the nuclear reactor cooling function was operated by injection, depletion of the water source for injection or the loss of power supply made it impossible to prevent core damage. The Station's container cooling function was not operated sufficiently. After that, reactor depressurization also took time. After depressurization, the reactor injection by heavy machines such as fire engines was not set as an accident management countermeasure, which made the situation very difficult. Thus, the reactor and container lost their cooling functionality and, the accident escalated.</p> <p>Due to this, alternate cooling function of reactor and container should be assured by having various alternative injection functions, various water sources for injection and increasing the capacity of such injection, introducing an air cooling system, and ensuring an alternative ultimate heat sink that lasts for a long time.</p>	<ul style="list-style-type: none"> Entrepreneurs were asked about the necessary measures required to ensure a means of water injection. Necessary countermeasures includes the following; ensuring a water source for injection to the reactor and container, such as seismic retrofit for an intake pit or large fresh water tank; intensifying an inspection of components of a containment spray ring; installing a suction pump to a reservoir, seawater pit or pump which can perform external injection to the reactor and steam generator without a power supply; maintenance of injection equipment such as DG drive pump, high-pressure piping. The entrepreneurs were also asked about the necessary measures required to ensure the heat sink used for removing decay heat and waste heat from auxiliary equipment. These measures include an intake pit installation for cooling by seawater, deployment of intake pump spare parts, diversification of intake parts, and development and maintenance of an air- cooled system. <p>[September 11, 2011 attached government report] As a future measure, seismic retrofit of a large-scale fresh water tank etc. are planned.</p>	<p>In this accident, the external power supply was lost due to the earthquake, and the seawater pump was flooded by the tsunami. This resulted in a station blackout and loss of seawater cooling function. Regarding RCIC, HPCI, and IC, the reactor core cooling system can be used even at the time of a station blackout, but this function was lost due to the loss or depletion of a DC power supply. For this reason, the following measures are considered necessary. These measure examples can be considered as multilevel measures by combining them with the conventional equipment.</p> <p>(1) Injection cooling function of reactor is secured as follows; ensuring means of injecting water into the reactor by a portable power pump which is independent from the existing power supply; ensuring a water source for injection including seawater; ensuring a backup power supply necessary for SRV operations because it is imperative to securely depressurize the reactor by SRV during injection.</p> <p>(2) The ultimate heat sink must be ensured by promptly restoring a seawater pump and seawater system by arranging spare parts.</p> <p>(3) An alternative ultimate heat sink must be ensured to prevent heat from escaping to the atmosphere through containment vent.</p> <ul style="list-style-type: none"> Items mentioned in this report 4.8.1 Injection to reactor 4.8.2 Seawater cooling loss Counter-measures example Heat sink loss correspondence (1), (2), (8) to (11)
(4) Securing cooling function of spent fuel pool without a fail		<p>This time, the cooling of the spent fuel pool became impossible because there was a loss of power supply. Such cooling could have prevented a severe accident so it is necessary to have a method to cool the spent fuel pool while dealing with the accident at the nuclear reactor. Until now, the risk of major accident at the spent fuel pool was considered minor compared with the risk of a reactor accident. Because of this, measures like alternate injection were not considered.</p> <p>For this reason, even when the power supply is lost, cooling must be secured by introducing an alternative cooling function of a natural circulation cooling system or air</p>	<p>The plant operators were asked to have the measures required to ensure a cooling function of a spent fuel pool. This includes seismic retrofit of the cooling system piping of a spent fuel storage pool; ensuring the power supply from an emergency power supply to the water gauge and thermometer of a spent fuel pool; strengthening checks on the cooling pump of a spent fuel pool; strengthening the monitoring of a spent fuel pool (ITV etc.);</p>	<p>To secure the cooling function of a spent fuel pool, it is extremely important to maintain water level so that the spent fuel is not exposed even at the loss of cooling function. For that purpose, an alternative injection means must be secured. For example, ensure a means of injection with fire engines or pump cars and ensure there is a corresponding injection route and water source.</p> <p>Moreover, in order to check the validity of an alternative injection measure, the Station must enhance the monitoring function of the</p>

Group name	Items	Contents	Additional requirements in attachment data	Comparison with the measures of this report
		cooling system, and having an alternative injection function so that cooling of a spent fuel pool can be maintained.	introducing dry cask storage. [September 11, 2011 attached government report] As a future measure, seismic retrofit of cooling piping of a spent fuel pool, etc. are planned.	pool water level and pool water temperature. For example, a power supply to level instrumentation and thermometer from emergency power source, or status monitoring enhancement of pool using ITV of battery drive measures can be considered. Thus, there is possibility of securing integrity of the spent fuel by performing injection to the spent fuel pool and maintaining the pool water level. For further reliability, an example of a measure is one which maintains the Station's cooling function. ■ Items mentioned in this report 4.11 Ensuring integrity of spent fuel ■ Measure example Ensuring integrity of spent fuel (1) to (3)
	(5) Accident management (AM) measures compliance	This accident was severe. To minimize the possibility of a severe accident or mitigate the influence of a severe accident, the accident management measures were introduced also in the Fukushima Nuclear Power Station. From the viewpoint of this accident, part of the alternate injection system for the reactor from the Fire Service Water System was working, but various power supplies or reactor cooling functions failed and accident management measures were insufficient. Moreover, these are fundamentally considered to be a Station operator's independent measure, and there was no demand for laws and regulations but maintenance was lacking. Furthermore, since accident management guidelines were designed in 1992, they had not been reexamined, improved and reinforced. For this reason, accident management measures should be performed for preventing severe accidents effectively and efficiently. These measures are, self-control safety precautions re-modified by a plant operator. This should be done at the demand of laws and regulations. Probabilistic valuation techniques need to be applied while re-modifying design requirement items.		Power plant regulations are the jurisdiction of the country and a subject are not raised in this report made by the industrial world. However, the validity of using PSA would be recognized from this accident, and here onward the use of PSA will be considered. Measures are examined in multiple ways. Valid measures for severe accidents such as preventing the outbreak of an accident are strongly recommended in [4.5 chapter measures collection].
	(6) Handling problems of multiple furnace locations	This time, accidents occurred simultaneously at multiple furnaces, and the resources required for handling the accidents were distributed thinly. Moreover, the two nuclear reactors shared equipment and the physical gap between them was very small, so emergency response to at the adjoining reactor was affected by the progress of the other reactor accident For this reason, when multiple nuclear reactors are located in one plant, and if an accident occurs in one reactor, the operations of the other reactor should be separated and executed independently. Also, the engineering independency of each nuclear reactor should be ensured and care should be taken so that the impact of the reactor where the accident occurred should not extend to the adjoining reactor. Moreover, it is recommended that a chief person should be assigned for each unit to ensure reactor safety, and he or she should handle multiple accidents independently.	Plant operators were asked about the necessary measures for accidents that occurred in the same site, to ensure the period necessary for safety, thoroughly isolate the building period, ensure the engineering independency in the location of multiple units etc (rationalization of arrangement of a reactor building and a turbine building). [September 11, 2011 attached government report] Hereafter the verification of the policy for making engineering independency of each nuclear reactor in multiple furnace locations in a more secure way, is scheduled.	At present, the level or problem of influence on specifically handling accidents in multiple furnace locations is not clear, other than the influence on the adjacent unit work in which the hydrogen that occurred at Unit 3 started an explosion when it leaked from the exhaust line to Unit 4. If more information on multiple furnace locations comes to light in the process of accident investigation here onward, we will consider examining concrete measures. For the time being, training will be conducted by considering the occurrence of simultaneous accidents at two or more furnaces. In it, we will reexamine the procedures and the necessity for reexamination of staff disposition.
	(7) Consideration on basic designs of nuclear power station arrangement	This time, it was hard to handle the accident as the spent fuel pool was located high up in the reactor building. Moreover, the Station could not stop the contaminated water of the reactor building from going between the turbine building and another building. For this reason, regarding basic designs of nuclear power station arrangement, the facilities and buildings should be suitably arranged from now on, which will make it possible to carry out secure cooling even when a serious accident is occurred and prevent expansion of an accident. In that case, the additional measure for having an equivalent function is taken for the existing facilities.	Plant operators were asked for rationalization of arrangement of a reactor building and a turbine building, etc. [September 11, 2011 attached government report] Materialization of examination is planned by considering suitable arrangement of facilities of the nuclear power stations and buildings, etc. in the basic design for nuclear reactor establishment etc.	In a newly constructed plant, about arrangement of apparatus, designs should be made in such a way that they reflect this accident perception. For the existing plant, concrete examples of measures must be followed to fill in the gap between the ideal situation and the present reality. When examining an injection route to a spent fuel pool, it is necessary to consider countermeasures if the pool is located at high altitude. • Injection of water by fire engines, pump trucks and such like, as well as water injection route and water source should be ensured. Countermeasures must be taken such as watertightening of a breakwater and compartment, or sealing the penetration area, with respect to the installation location or installation conditions. • Build a sea wall or breakwater and also build a protective wall for important installations. • Evaluate the impact of tsunami that exceeds the site height. , buildings outdoors, air supply opening aperture & penetration with respect to flood height. For external gates of the building and air supply openings and penetration area, implement flood

Group name	Items	Contents	Additional requirements in attachment data	Comparison with the measures of this report
				<p>prevention countermeasures, such as sealing improvement.</p> <ul style="list-style-type: none"> • Evaluate the impact of tsunami that exceeds the site height, and improve watertightening for basement gates and gates that lead to the basement floors, where there are safety-related equipment that require flood prevention measures. This way flooding impact can be minimized. • Deploy portable drainage pumps to drain seawater inside the building for early restoration. • Give consideration to the impact of tsunami wave when external gates facing the sea could be exposed to direct impact of a tsunami. • Take flood prevention measures like a water prevention wall around a seawater pump. • Deploy motor spare parts for early restoration • Deploy movable seawater pumps or waterproof pumps. <ul style="list-style-type: none"> ■ Items mentioned in this report <ul style="list-style-type: none"> 4.6.2 Tsunami flood prevention within the premises 4.6.3 (1) Watertightening of important facilities 4.6.3 (2) Flood countermeasures of seawater system 4.11 Ensure integrity of spent fuel ■ Counter-measures <ul style="list-style-type: none"> Provisions against earthquake and tsunami (1) – (9) Ensure integrity of spent fuel (1) – (2)
	(8) Ensuring watertightening of important facilities	<p>One of the reasons this accident occurred was that a lot of important equipment facilities, such as seawater pumps for auxiliary cooling, Emergency Diesel Generator and switchboard, were flooded in the tsunami. As a result there were difficulties in ensuring an electricity supply and cooling system.</p> <p>From the viewpoint of achieving the desired level of safety, assume that a tsunami that exceeds the design comes. Ensure the important safety even if there is a flood that exceeds the design assumptions for sites adjacent to rivers. Specifically, install gates that can handle the destructive force of a tsunami or flood, put blocks in the piping or flood pathway, use waste water pumps, and ensure the watertightening of important equipment.</p>	<p>Move and distribute safety-related control devices to upper floors or high ground, order the workers to take countermeasures to ensure water tightening of important facilities.</p>	<p>First, make scientifically reasonable assumptions to evaluate the tsunami height. For that 1) “ensuring the necessary sight height” is the top priority countermeasure. But from a multi-layered protection viewpoint, assume a tsunami that exceeds the site height, and according to the pushing and pulling force of a tsunami, investigate how to prevent important safety facilities from being destroyed. Carry out 2) “defense of a breakwater or such like.” Moreover, assuming a tsunami that is exceedingly large, 3) Countermeasures such as “installing watertightening gates” or “improving sealing of the openings” should be taken for places where seawater intrusion can cause the functional loss of safety-related facilities. Those places, such as openings of the building, can become pathways for seawater to infiltrate. Assume that the Station cannot prevent a tsunami from entering the building even after all those measures were taken, and ensure safety functions by performing 4 “water tightening of each compartment,” ensure the safety functions. Also assume that the water may still enter the water tightening compartments. Have countermeasures such as 5) “deployment of a drainage pump” to remove the flood water as early as possible.</p> <p>For temporary power supply system, 6) “move and deploy at upland where tsunami cannot reach.” In the situation where possibilities of tsunami impact are totally eliminated, a back-up system is expected to work even when the existing power supply fails.</p> <p>Like this, multi-layered countermeasures must be developed for tsunami. Assuming these countermeasures, the loss of function that may cause a power supply failure, heat sink failure and other common-factor failures can be prevented and the accident can also be prevented from escalating.</p> <ul style="list-style-type: none"> ■ Items mentioned in this report <ul style="list-style-type: none"> 4.6.2 Flood prevention from tsunami within the premises 4.6.3 Flood prevention measures for building 4.7.1 Station blackout and loss of DC power supply ■ Countermeasures <ul style="list-style-type: none"> Provisions for earthquake and tsunami (1)-(3), (5) Power supply preparation (1)-(3), (5), (6) Heat sink failure measures (12)
Responding to incidents in severe	(9) Reinforce the countermeasures for prevention of hydrogen	<p>In the present accident, there was a hydrogen explosion in the Unit 1 of reactor building at 15:36 on March 12, and in Unit 3 of the reactor building at 11:01 on March 14. Moreover, there was an explosion which seemed to be due to hydrogen in Unit 4 at</p>	<ul style="list-style-type: none"> • With respect to BWR, decisions must be made and measures taken with the objective of preventing a hydrogen explosion and hydrogen 	<p>Based on the design standards up till now, with respect to the hydrogen which can be generated due to acid reaction of nuclear reactor coolant with fuel cladding tube, hydrogen is prevented from</p>

Group name	Items	Contents	Additional requirements in attachment data	Comparison with the measures of this report
accident	explosion	<p>15:06 on March 15. That is, no help was received from the initial explosion of Unit 1 and the conditions were such that the explosions occurred in continuation, and that was a major factor that made the present accident worse. In order to maintain the integrity of the containment vessel in a boiling water reactor, as per the design standards, the inner part of the containment vessel was inactivated, and a flammable gas control system is setup. However, it was not assumed that there would be a leakage of hydrogen gas in the nuclear reactor building that would lead to conditions that can create an explosion. Hence, hydrogen countermeasures were not implemented in the nuclear reactor building.</p> <p>In order to precisely reduce or release generated hydrogen, along with the hydrogen-related countermeasures for the containment vessel, it is necessary to reinforce the hydrogen explosion prevention countermeasures for the flammable gas control system setup in the nuclear reactor, which is used in the event of severe accidents and completion of facilities in order to let the hydrogen escape outside.</p>	<p>outlet should be ensured by securing means of blowout panel opening.</p> <p>For BWR, measures must be taken to prevent hydrogen from accumulating in the flammable gas control system in the nuclear reactor building. Based on the analysis of the conditions in Fukushima Daiichi (leakage), important hydrogen explosion countermeasures include having a hydrogen detector device within the building, or setup in the nuclear reactor building for hydrogen vent to release hydrogen.</p> <ul style="list-style-type: none"> For PWR, the power supply for the annulus exhaust system by a power supply vehicle to let hydrogen escape at the time of leakage, power supply for the igniter for the power supply vehicle (hydrogen ignition device) should be ensured. Important countermeasures against hydrogen explosion include installing a Passive Auto-Catalytic Recombiner on a containment vessel. <p>[Refer September 11, 2011 government report] About the medium- to long-term efforts hereafter</p> <ul style="list-style-type: none"> For BWR, it is planned that the hydrogen vent device should be installed at the top of the nuclear reactor building. A hydrogen detector should be set up inside the nuclear reactor building. For PWR, it is planned to set up a device which will reduce the concentration of hydrogen inside the containment vessel of Passive Auto-Catalytic Recombiner, which does not use a power supply. 	<p>being generated by cooling the reactor with an emergency reactor cooling system or in the case of boiling water reactor (BWR), the deactivation is done by including nitrogen in the nuclear reactor containment vessel and hence even if hydrogen leaks by some chance, the atmosphere inside the nuclear reactor containment vessel remains below combustible limits.</p> <p>However, in the case of a BWR, due to circumstances which were outside the design scope, there was hydrogen leakage from the same container to the inside of the nuclear reactor building. For this, following countermeasures:</p> <p>(1) "Countermeasures for releasing the hydrogen stagnated in the nuclear reactor building or reducing its concentration," (2) "Based on the analysis of the path where hydrogen leakage had occurred, setting up of the hydrogen gas detector system, which will carefully monitor the accumulation of hydrogen gas inside the nuclear reactor building" are proposed.</p> <p>Moreover, in order to prevent the collection of hydrogen inside the nuclear reactor building, at the time of containment vessel venting corresponding to severe accident, the following countermeasures:</p> <p>(3) "In case junction is present in the containment vessel vent line, prevention of circulation of hydrogen from that exhaust pipe," (4) "Prevention of circulation of hydrogen in the other units sharing the exhaust pipes" are proposed and the prevention of accumulation of hydrogen inside the reactor building is done.</p> <p>Thus, for the hydrogen which may be generated in the reactor core, the explosion due to hydrogen accumulation in the reactor building is prevented by securely implementing these countermeasures, and the severity of the accident can be prevented.</p> <p>Furthermore, if the countermeasures for prevention of generation and release of hydrogen are certainly implemented, it is possible to prevent hydrogen explosion, and the setup of flammable gas control system inside the reactor building for BWR is not considered essential.</p> <ul style="list-style-type: none"> Items mentioned in this report 4.9 hydrogen countermeasures Examples of countermeasures Hydrogen countermeasures (1) to (4)
	(10) Reinforce containment vessel vent system	<p>In this accident, there were problems in operating the containment vessel vent system when the severe accident occurred. Also the containment vessel vent system could not remove radioactive materials sufficiently. Hence accident management could not make effective use of countermeasures. Also the vent line could not be isolated and so the connecting possibly had a bad impact on other areas.</p> <p>Hence hereafter, the Station must improve operability of containment vessel vent system and secure its independency, reinforce the radioactive material removal management and hence reinforce the containment vessel vent system.</p>	<ul style="list-style-type: none"> Operators will be asked to take necessary countermeasures at reinforce of containment vessel vent, such as installation of filter at vent, design of rupture disk, evaluation of operating condition or review, installation of accumulator at vent AO valve, independence of vent exhaust line which was assumed at accident, and reinforcing leakage prevention at adjacent Unit. <p>[September 11, 2011 Government Report] By doing a broader study of domestic technical knowledge, reinforce radioactive material and work out reinforcement of containment vessel vent system</p>	<p>Containment vessel vent has post-accident over pressure prevention and heat release functionality as severe accident countermeasures. To ensure the actual vent functionality, the following is proposed as line configuration countermeasure;</p> <p>1) Prepare for existing source failure, ensuring necessary backup driving source (electricity / pump) for operation of containment vessel vent valve.</p> <p>Considering the possibility of damage due to excessive temperature, procedure for vent operation should also be reviewed.</p> <p>2) "Optimization of operating conditions for vent," Investigation about "leakage (wraparound) prevention to adjacent unit through exhaust line."</p> <p>3) Moreover, cooling by containment vessel alternative spray after the core damage should be investigated as a countermeasure.</p> <ul style="list-style-type: none"> Items mentioned in this report 4.8.3 Containment vessel vent 4.9 Hydrogen countermeasures Countermeasures Measures for heat sink failure (3) – (5) Hydrogen countermeasures (3)
	(11) Strengthening the environment to handle the accident	<p>At the time of this accident, the radiation dose of the central control room was increased, once the conditions were such that the workers could not even enter and it was difficult to do work for a long time. Hence, habitability of the central control room decreased. Moreover, there was a radiation dose increase even in a nuclear power plant emergency support facility, which became a central location for emergency countermeasures implementation. It became more and more difficult to perform the activities to handle this accident due to worsening of communication environment or</p>	<ul style="list-style-type: none"> Ensure that the emergency power supply is available for in campus PHS communication system, ensure communication tools such as transceivers, ensure portable lighting devices, maintain radiation shielding function of central control room corresponding to ventilation and air conditioning system installation for emergency 	<p>To ensure habitability inside the central control room, set up a central control room ventilation system containing charcoal filter for removing iodine while designing shielding, ensuring that the conditions are livable for workers even at the time of an accident.</p> <p>However, due to the station blackout, the central control room ventilation system containing charcoal filter for removing iodine could not function and hence the following countermeasures are required:</p>

Group name	Items	Contents	Additional requirements in attachment data	Comparison with the measures of this report
		<p>lighting conditions.</p> <p>Hence, the protection of central control room or emergency support facility from the radiation, exclusive ventilation and air conditioning system on the site should be reinforced. The communication which will not depend on AC power supply, setup of lighting-related systems should be reinforced. Even if a severe accident occurs, the activities to handle the accident should be able to be continued and such an environment should be reinforced.</p>	<p>power supply vehicle and completion of such infrastructure of the environment corresponding to the accident situation is demanded.</p> <ul style="list-style-type: none"> Reinforcement of communication system (diversification of electric supply) and reinforce the functions of emergency room (ensure isolation, shielding, important personnel skills). The aseismic reinforce for administration building, countermeasures to reinforce the environment corresponding to accident should be implemented by operators. <p>[Refer September 11, 2011 government report] Along with shifting the PHS etc. devices within the site, to higher elevation, reinforcing the functions of emergency room or aseismic reinforce of administration building is planned.</p>	<p>(1) "Ensure the availability of power supply to the central control room ventilation system so as to perform functions in case of emergency. Moreover, complete the operation procedures for this." Also, (2) "Investigate the main cause for rise of radiation dose in the central control room, reinforce the countermeasures for radiation protection of the central control room" are proposed.</p> <p>Hence it is possible to improve the environment corresponding to the accident, by implementing the countermeasures for improving the habitability of the central control room at the time of accident.</p> <p>Regarding communication system, which is an important device for support in unusual conditions of class 3 importance classification, it is ensured that the authenticity is maintained at least equal or above the general industry facility.</p> <p>However, if natural phenomenon much beyond the assumptions occur, similar to this time, it is feared that such communication systems become unusable and hence regarding communication facility within the power plant as well as with the outside, the following countermeasures are proposed.:</p> <ol style="list-style-type: none"> Ensure a self-reliant backup supply system which is not affected by earthquake, tsunami etc. Implement the facilities such that they are not cut off easily due to earthquake, tsunami etc. Deploy multiple means of communication <p>Also, from a viewpoint that the information sharing with the actual site should take place smoothly without a fail at the time of accident</p> <ol style="list-style-type: none"> Necessary number of communication devices should be set up in the places including the actual site. It is proposed that the countermeasures such as mastering the operation by conveying the definition of the method of practical use and practice etc. <p>Such important countermeasures for maintaining the communication environment at the time of accident have been proposed and because of these countermeasures, the communication within the power plant as well as with the outside is maintained even if unusual natural phenomenon exceeding all the assumptions occur. This makes it possible to conduct incident response activities more smoothly and securely.</p> <p>In case of severe natural phenomenon, such as earthquake or tsunami, station blackout for a long duration, and severe conditions such as release of large amounts of radioactive material in the environment, the functions of emergency support facility become important. Hence arrangements should be made such that these functions should be served even when assuming these conditions.</p> <ol style="list-style-type: none"> The structure should be resistant to the assumed earthquake or tsunami. Ensure an emergency power supply which is independent from the plant. Ensure monitoring important plant parameters and means for communication with the central control room and actual site. Radiation protection countermeasures. Taking into consideration the things such as ensuring habitability of necessary person corresponding to emergency conditions and securing important materials and equipment, complete the emergency plant. <p>Regarding the emergency support facility, all the aspects are extensively considered, if the environment corresponding to the accident is reinforced by implementing these countermeasures, the incident response activities can be carried out more smoothly and security.</p> <p>■ Items mentioned in this report 4.10.2 Central control room air conditioning, shielding 4.10.7 Communication</p>

Group name	Items	Contents	Additional requirements in attachment data	Comparison with the measures of this report
				<p>4.10.4 Emergency support facility</p> <ul style="list-style-type: none"> ■ Example of countermeasures Arrangements for emergency situations. (6), (7),(13), (22) to (28),(30) to (33)
	(12) Reinforcement of radiation exposure administration system at the time of accident	<p>In this accident, many individual dosimeters or radiation reading devices were immersed in seawater due to the tsunami and become unusable. Hence adequate radiation measurement control was difficult; personnel engaged in radiation work were forced to get involved in field works. Also air radioactive material measurement was delayed, increasing the risk of internal exposure.</p> <p>Hence, at the time of accident, individual dosimeter or radiation protection equipment should be kept in abundance. Make a system that allows expansion of radiation control personnel at the time of accident. Develop a system and facility to promptly measure radiation workers' exposure, and reinforce radiation exposure control system at the time of accident.</p>	<ul style="list-style-type: none"> • Ensure seeking of more individual dosimeter based on number of people at emergency work at the time of accident • Seek system completion for expandable radiation control personnel at the time of accident. 	<p>Based on this accident, when a severe accident occurs, incident response activities in high radiation environment become necessary. Besides, there could be a situation in which radiation control may become essential in areas where in normal times radiation control is not required. Furthermore, severity of natural phenomena and power failure of power plant can be considered as the factors of the severe accident. They can lead to considerable confusion.</p> <p>To perform adequate radiation control and prevent workers from excess exposure in such a situation, the following countermeasures are under proposal.</p> <p>(1) Ensure materials and equipment necessary for radiation control. (2) Ensure adequate radiation control personnel. (3) Measures to avoid unwanted radiation exposure.</p> <p>Specifically about (1), considering station blackout, preparation of radiation measurement instrument, accommodating the radiation measurement instrument for alternate power supply, reviewing the number of protection equipment based on the accident, (2) is about deployment of radiation control support system, (3) is about information sharing on radiation etc.</p> <p>Apart from these countermeasures, deployment of emergency support facility, which has taken measures for radioactive protection as a completion of support environment at the time of accident, is demanded. Also, it is pursued to take measures to prevent each type of accident and furthermore, considering occurrence of accident and then taking countermeasures to reduce radiation exposure</p> <ul style="list-style-type: none"> ■ Items mentioned in this report 4.10.5 Radiation control / Work management ■ Example of countermeasures Preparations corresponding to emergency (1) to (5)
	(13) Reinforce practice for dealing with a severe accident	<p>In case of severe accidents, to deal with nuclear power plant accidents, effective practice for implementing convergence of related facilities was not much in place till now. In this accident, for instance, time was needed to establish cooperation between the emergency support facility, Nuclear Emergency Response Headquarters and Local Nuclear Emergency Response Headquarters inside the power plant, cooperation between the Self-Defense Forces, police, fire department which played an important role in dealing with an accident. This could have been also prevented by implementing precise practice.</p> <p>Hence, when a severe accident occurs, smoothly carry out incident response activities, grasp the situations of both inside and outside of the power plant, conduct emergency assembling of skilled persons who are necessary for ensuring the safety of local residents. Practice for severe accidents must be reinforced so that related administrative agencies can work in cooperation.</p>	<ul style="list-style-type: none"> • It is pursued that workers should carry out the practice to deal with emergency conditions with assumptions of occurrence of severe accident due to breaking of primary coolant etc., as well as its prolonged duration and severe conditions. • Important countermeasures are demanded from the workers regarding practice for dealing with terrorism. <p>[Refer September 11, 2011 Government Report] The country will ask workers to carry out the practice to deal with emergency conditions with assumptions of occurrence of severe accident due to breaking of primary coolant etc., as well as its prolonged duration and severe conditions.</p>	<p>It is assumed that, when a severe accident takes place, then the incident response activities are mainly focused on field works. Also the field works are assumed to be executed under severe working conditions and hence, take the following countermeasures:</p> <p>(1) The knowledge and abilities required from each necessary person should be sorted out and practice should be done based on this. (2) Execute practice of activities on actual site related to accident management. (3) It is proposed to execute counter-measurescountermeasures by carrying out practice in modeled severe conditions such as night time work, heavy equipments etc.</p> <p>Also, in order to be able to properly deal with events as they progress, it is proposed that the countermeasures as below should be executed:</p> <p>(4) High level executions such as blind practice, real time practice etc. is carried out. (5) Accessing the actual site or prior confirmation of the required time for the actual work (6) Practical usage of simulator etc.,</p> <p>Thus, without forgetting the lessons learned this time, accident management practice at the time of occurrence of a severe accident should be completed and carried out continuously; due to which it is thought that it is possible to perform incident response activities much more smoothly to deal with accident.</p> <p>Moreover, there is a plan to conduct investigation afterwards regarding the nuclear reactor emergency practice to be executed by the country as well as self-governing organizations, but the workers should deal appropriately on the basis of this analysis result and should cooperate positively.</p>

Group name	Items	Contents	Additional requirements in attachment data	Comparison with the measures of this report
	(14) Reinforce the instrumentation system of nuclear reactor as well as containment vessel	<p>It was difficult to ensure important information such as water level or pressure of nuclear reactor, source of release of radioactive material, release quantity quickly and accurately, because the instrumentation system of nuclear reactor and containment vessel did not work under severe accident conditions.</p> <p>Hence, reinforce the instrumentation system of the nuclear reactor and containment vessel which performs sufficient functions at the time of severe accident.</p>	<ul style="list-style-type: none"> It is demanded that the business workers should reinforce development as well as completion of instrumentation system of pressure vessel and containment vessel, which performs sufficient functions at the time of severe accident, and that of spent fuel pool and the instrumentation system for understanding the situation. <p>[Refer September 11, 2011 Government Report] Planning the preparation and development of the instrumentation system of the nuclear reactor and containment vessel which performs sufficient functions at the time of severe accident as well as instrumentation system of spent fuel pool.</p>	<ul style="list-style-type: none"> Items mentioned in this report 4.10.1 Practice Examples of countermeasures Arrangements related to emergency (14) to (19) <p>Regarding the instrumentation system of the nuclear reactor and containment vessel, monitoring within the estimated scope for fluctuations was possible at the normal operation/operation when there was abnormal change till now; To take measures at the time of accident after knowing about the accident, the design is capable of monitoring important parameters by distributing over a sufficient scope using proper methods.</p> <p>However, the supply of the meter is lost due to loss of functionality of DC power supply system and station blackout for long duration, the important parameters, the measurement or recording of important parameters was not possible and hence, the following measures are proposed:</p> <ol style="list-style-type: none"> "Install temporary storage battery or connection cable in the vicinity of central control room for electricity backup." "Reconsider conservation of electric power of the meter or non-failure of electricity as per requirement." <p>Also, under the conditions at the time of occurrence of severe accident, it was not assumed that there will be circumstances which lower the range of measurement of the water level meter and hence, the following measure is proposed.</p> <ol style="list-style-type: none"> "Consider the occurrence of severe accident, development of the meter system with wide range of measurement of reactor water level or investigate the means to understand the condition of the nuclear reactor from containment vessel meter, even if the reactor meter became nonfunctional." <p>Also, there was no measurement requirement till now, for the things such that hydrogen concentration of the nuclear reactor building and hence, support cannot be given to those items which were other than the requirements for measurements. Considering this, the following action is proposed.</p> <ol style="list-style-type: none"> "Establish a measurement system for the parameters such as concentration of hydrogen inside the nuclear reactor building." <p>Furthermore, the means for confirming authenticity of measurement system for important parameters such as nuclear reactor water level etc., under the circumstances of occurrence of severe accident and hence the following action is proposed</p> <ol style="list-style-type: none"> "Considering the occurrence of severe accident, development of measurement system to reinforce diverse environmental qualifications, measurement methods etc." <ul style="list-style-type: none"> Items mentioned in this report 4.10.3 Measurement at the time of accident Examples of countermeasures Preparations to deal with emergency (8) to (12)
	(15) Focused management of equipment for emergency operations and deployment of rescue team forces.	<p>In this accident, around the J village, all the concerned persons handling the accident or disaster victim concentrated the materials and equipment and are providing earnest support from behind. Initially, though people were there in the surrounding area, the mobilization of the part of rescue team forces, supporting the activities of accident management and emergency support materials and equipment, could not be carried out fast as earthquake or tsunami disaster had occurred. Therefore incident response on the site was not sufficient.</p> <p>For this, the completion of the rescue team supporting the management of emergency support materials and equipment and their practical use, is promoted so that the emergency operations can be smoothly carried out even in case of severe conditions.</p>	<ul style="list-style-type: none"> In order to carry out restoration rapidly at the time of accident, sufficient heavy equipment to process rubble should be deployed. Ensure sufficient protection clothes, protection mask under high radiation dose, the procedures for doing transactions between the enterprises during a period of dealing with accident, should be defined. Complete the management system of collection of all the materials and equipment for emergency operations including robots or unmanned helicopters. Complete one part of the rescue team forces having high level of skills of supporting emergency conditions by practically using these pieces of equipment, and reinforce the tie with related administrative agencies. 	<p>To have various means of transport by assuming conditions such as blocking of access route or simultaneous occurrence of accident in multiple units, and about the preparation of materials and equipment, the lessons from the accident this time, are:</p> <ol style="list-style-type: none"> Bringing of necessary heavy equipment and materials and their deployment Establish the means of air transport as well as transport through sea, instead of land transport, completion of its setup Reconfirm and arrange the means of a flexible system between enterprises. Establish equipment or devices (robots, unmanned helicopters etc.) for remote operation under high radiation conditions as nuclear disaster countermeasures. Cooperation for the investigation committee concerning the development and practical use of such equipment, as well as, for actual bringing in of the equipment, perform setup of cooperation between the enterprises and related administrative agencies.

Group name	Items	Contents	Additional requirements in attachment data	Comparison with the measures of this report
				<p>Investigation is done in corporation to promote completion of one part of the rescue forces, while using the existing resources from the country or self-governing body. Also, it is considered that there can be conditions when transportation by normal means is not possible. The cooperation is planned beforehand such that requests for cooperation of Self-Defense Forces etc. is possible.</p> <ul style="list-style-type: none"> ■ Items mentioned in this report <ul style="list-style-type: none"> 4.10.9 Provision for emergency countermeasures (heavy equipment, rescue), cooperation set-up in case of emergency ■ Examples of countermeasures <ul style="list-style-type: none"> Preparations to deal with emergency (20), (21),(41) to (43)
Support for nuclear hazard	(16) Support for complex circumstances of nuclear reactor disaster and large scale natural calamity	<p>This time, along with a large-scale natural calamity, there was a nuclear reactor accident leading to extreme difficulties with respect to contact, communication, assembling of people, provision of goods. Also, due to prolonged period of reactor accident the measures for evacuation of local residents have been forced to prolong though it was initially assumed to be for a short duration.</p> <p>For this, support for the conditions when a large-scale natural calamity as well as nuclear reactor accident simultaneously occurred, the system and environment should be established which will ensure appropriate means of communication and method of supply of materials. Also, it should be assumed that the nuclear reactor accident can occur for a long time and reinforce the support for mobilization of important persons from every field related to support for accident or disaster.</p>		<p>Presently, it is being investigated how a country and self-governing bodies will support basic disaster prevention plan, and also how enterprises will support the plan in response. Corresponding to the complex conditions, it is necessary to review this basic disaster prevention plan. Afterwards, enterprises will need to review their support corresponding to the nation's investigation. However, this report proposes to carry out the reinforcement of arrangement of communication devices and materials and equipment. Hereafter, we aim to support investigation of added countermeasures and ensure means of communication with the country, in wider investigations carried out with the nation.</p> <ul style="list-style-type: none"> • Backup power supply such as battery which is independent of the nuclear reactor facility and does not have any impact of earthquake, tsunami etc., is allowed. • The facility should be done such that the communication setup for server and converter etc. which are used in case of emergency, cable communication circuit and wireless relay base, should not cut off easily due to natural calamities such as earthquake, tsunami etc. • Deploying various communication equipment such as exclusive circuit, satellite phone and, wireless devices etc., and clarify the method of use of these devices. <p>Assuming the conditions such that, due to natural calamity (earthquake, tsunami), when the access route inside the power plant from outside is blocked, the consolidation of heavy equipment to remove rubble should be done. The diversification of methods of transportation of people and materials and equipment is essential, hence considering the cooperation with the related administrative agencies, basically, the following support is thought of :</p> <ul style="list-style-type: none"> • Identifying and deploying essential heavy equipment other than foil holder which is deployed for severe accident countermeasures. • Completion of establishment and setup of means of air transport, sea transport which can replace the current land transport • Based on the support for this accident, identification and deployment of essential materials and equipment as well as reconfirmation of necessary quantity of them. • Reconfirm the flexible system between enterprises for emergency operations and deploy its means • Establish equipment and devices (robots, unmanned helicopters etc.) for remote operation under high radiation conditions, of the reactor in case of emergency. Cooperation for the investigation committee concerning the development and practical use of such equipment, as well as, for actual bringing in of the equipment, perform setup of cooperation between the enterprises and related administrative agencies. <ul style="list-style-type: none"> ■ Items mentioned in this report <ul style="list-style-type: none"> 4.10.7 Communication 4.10.9 Preparation of emergency countermeasures (heavy equipment, rescue), cooperation setup for emergency

Group name	Items	Contents	Additional requirements in attachment data	Comparison with the measures of this report
	(17) Reinforcing environment monitoring	<p>Currently, emergency environment monitoring is the duty of local government. However, as the environment monitoring equipment and facilities were damaged by earthquake and tsunami, and forced to evacuate from base facility for emergency response and countermeasures, it was not possible to perform adequate environment monitoring initially. To compensate this, Ministry of Education, Culture, Sports, Science and Technology have had corporation from related administrative agencies to perform monitoring activity.</p> <p>Hence, in the case of emergency, it is the nation's responsibility to build up the system to perform environment monitoring both securely and systematically.</p>		<p>■ Examples of countermeasures Preparation with respect to emergency (13), (30) to (33), (20), (21), (41) to (43)</p> <p>According to the Basic Plan for Emergency Preparedness, environment monitoring in case of nuclear power disaster is to be implemented as follows: site boundary and its internal is monitored by operator and outside the site boundary is monitored mainly by local government.</p> <p>Due to the nuclear power disaster, cooperation support for environment monitoring of site boundary and within premises of power plant, which was supposed to be implemented by business operator, and similarly, environment monitoring outside the site boundary, which was supposed to be carried out by local government, was proposed as feasible countermeasures taken by business operator.</p> <p>It is essential to redeploy the industry's cooperation and support system for environment monitoring implemented by local government, and similarly, support structure between business operators. The contents were thought to be as below.</p> <ul style="list-style-type: none"> • Monitoring equipment necessary to accommodate in emergency, reconfirmation of instrument and deploying necessary numbers of them. • Review of necessary person for support for emergency operations, completion of rules related with that dispatch <p>Essential utility needs to be reinforced on constant set monitoring post, which is based on this natural disaster (earthquake, tsunami). The contents of reinforcement are thought as below</p> <ul style="list-style-type: none"> • Reinforce electric and communication line. • Tolerance reinforce against earthquake, tsunami <p>It is necessary to define alternative monitoring procedure when constant set monitoring post is not usable. The contents are considered as below</p> <ul style="list-style-type: none"> • Review of alternate measurement procedure such as constant set monitoring instrument • Deploy equipment and facilities that are required for measurement by alternative means and confirm how many they are. <p>■ Items mentioned in this report 4.10.8 Environment monitoring</p> <p>■ Examples of countermeasures Preparation for emergency operations (34)-(39)</p>
	(18) Definition of roles of local and central administrative agencies	<p>During the initial period of the accident, ensuring means of communication was difficult. From this it is seen that, starting from local and central agencies, the communication and cooperation between the related administrative agencies were not sufficient, also the sharing of roles as well as responsibility relationship was not always clear. Specifically speaking, regarding the relationship between Nuclear Emergency Response Headquarters and Local Nuclear Emergency Response Headquarters, relationship between government and TEPCO, relationship between TEPCO and the actual nuclear power plant site, sharing of roles among the internal departments of the government etc., the structure of rights and responsibilities had some uncertain things. Particularly, the mutual understanding between the government and TEPCO was not sufficient during the initial period of the accident.</p> <p>Hence, for this, the following are promoted: reviewing and defining responsibility relationship and sharing of roles among the related administrative agencies such as Nuclear Emergency Response Headquarters; defining responsibilities, roles and means of information contact; system deployment.</p>	<p>[Refer September 11, 2011 Government Report] Regarding the television conference used at the time of nuclear reactor disaster, the plan is to promote consolidation of the government administrative agencies and all the electric supply enterprises so that emergency instructions as well as information collection can be carried out clearly and rapidly, by connecting with the nuclear power plant.</p>	<p>As for the items necessary to be investigated by enterprises, considering the organization / command, order within the enterprises, instructions were given for the following countermeasures.</p> <p>Among the support operations in case of emergency, one is to define the time for doing judgment regarding the things which exert bad impact for the convergence of the accident if judgment delays. Preparations should be made such that analysis is done fast and operations can be carried out rapidly.</p> <p>About the basic conditions at the time of accident or the judgment, they can be clarified by interview of the concerned people made by the committee on Fukushima Daiichi Nuclear Power Station accident investigation and review. If new facts are identified, investigation should be done to decide whether the countermeasures and lessons should be added or not.</p> <p>Furthermore, regarding nuclear reactor disaster prevention countermeasures, country, local self-governing body, related administrative agencies and enterprises should implement as one body, for relation between the other agencies, enterprises should</p>

Group name	Items	Contents	Additional requirements in attachment data	Comparison with the measures of this report
				<p>take measures based on result of analysis made by the committee on accident investigation and review.</p> <ul style="list-style-type: none"> ■ Items mentioned in this report 4.10.6 Organization / command, order ■ Examples of countermeasures Arrangements corresponding to emergency (29)
	(19) Reinforce the communication related to the accident	<p>Regarding sharing of information with the local residents, in the initial period when accident has occurred, difficulties came due to damage of means of communication owing to the occurrence of large scale earthquake disaster. After this, even information communication with the local residents or with the self-governing bodies could not be achieved at proper timing. Moreover, there was no sufficient, easy-to-understand explanation regarding thinking of International Commission on Radiological Protection (ICRP) related to radiation protection, or health impact of radiation or radioactive materials for the local residents. Also, regarding official announcement of information to the nationals, the precise facts have always been announced to the public till now but the forecast of risks etc. have never been described in details and hence, there was anxiety regarding future happenings.</p> <p>Hence, we strengthen sharing of accurate information on the accident situation/response it with the local residents, giving proper explanation regarding impact of radiation. Regarding the information announcement when accident was progressing, attention should be given to the point that information should include the description of future risks etc.</p>		<p>In this large-scale accident, it was under the jurisdiction to give instructions regarding evacuation of local residents, hence this topic is not raised in this report which is for the industry.</p> <p>However, press was carried out on enterprise side also, and lessons should be extracted from the press conditions this time. The examples of countermeasures related to official announcement of environment monitoring data etc., are specified.</p> <p>It is required to define the means of communication or the contents of the necessary information to be communicated to general people, related administrative agencies, persons related to the actual site actual site. Following things are thought regarding this.</p> <ul style="list-style-type: none"> • Contents of information to be conveyed, the method of deciding this, sorting out necessary persons • Means for transmission (press, HP etc.) and study of official announcement timing <ul style="list-style-type: none"> ■ Items mentioned in this report 4.10.8 Environment monitoring ■ Examples of countermeasures Arrangements related to emergency (40)
	(20) Strengthening of dealing with aid from each nation and information sharing with the global community	<p>After the occurrence of this accident, the proposals regarding aid of materials and equipment from each nation could not be dealt sufficiently as there was no system in place within the government which will associate this with the needs in the country. Also the communication was not done beforehand with the neighboring countries and with the community about the release of water contaminated with low radiation levels. Thus there was no sufficient information sharing with the international community.</p> <p>Hence, an inventory list of materials and equipment should be prepared beforehand for international cooperation. In case of accident, the contact points of each nation should be clearly kept in advance. Strengthen the setup of information sharing by improving the international reporting system. Provide information that enables scientifically-sound response more rapidly and accurately. A proper structure should be formed for effective dealing with international world.</p>		<p>There is no topic raised regarding the government support offered by each country and information sharing with them in this industrial report. However, from now on, the investigation should be made regarding the cooperation between nuclear power industries of other countries such as WANO and INPO, and the national nuclear reactor related administrative agencies.</p>
	(21) Accurate understanding and prediction of impact caused by release of radioactive materials	<p>System for Prediction of Environmental Emergency Dose Information network system (SPEEDI) could not obtain information about the source of release of radiation. Hence impact of radiation based on the information about the release source could not be predicted eventhough that was the originally what SPEEDI should have done. Even under such constraints, certain assumptions should have been made, and the spreading tendency of the radioactive material should have been guessed using SPEEDI for reference for evacuation implementation. The calculation results of SPEEDI have currently been officially announced, but they should have been announced from initial stage.</p> <p>Hence, strengthen the measuring equipment which will clearly obtain the information about the source of release at the time of accident. Also, while making a plan to effectively utilize SPEEDI in various situations, the result of actions should also be officially announced from initial stage.</p>		<p>Effective use of SPEEDI is under the jurisdiction of government and hence no topic is raised in this industrial report.</p> <p>Countermeasures of strengthening the environment monitoring utilities of the nuclear power plant site boundary implemented by the enterprises are specified. They are not information about the source of release at the time of accident, but used to understand the impact of radioactive material release.</p> <p>It is necessary to strengthen important utilities for constant set monitoring post, based on this natural disaster (earthquake, tsunami). The contents to be strengthened are thought as below:</p> <ul style="list-style-type: none"> • Strengthening of electric supply and transmission line. • Strengthening the tolerance with respect to earthquake, tsunami <p>Also, to strengthen the means of communication with the outside, following countermeasures are specified.</p> <ul style="list-style-type: none"> • The facility should be done such that the communication setup for server and converter etc. which are used in case of emergency, cable communication circuit and wireless relay base, should not cut off easily due to natural calamities such as earthquake, tsunami etc.

Group name	Items	Contents	Additional requirements in attachment data	Comparison with the measures of this report
				<ul style="list-style-type: none"> ■ Items mentioned in this report <ul style="list-style-type: none"> 4.10.8 Environment monitoring 4.10.7 Communication ■ Examples of countermeasures <ul style="list-style-type: none"> Arrangements related to emergency (37),(38),(31)
	(22) Define the wide area evacuation and radiation protection standards at the time of nuclear reactor disaster	<p>In case of this accident, from the start of accident occurrence, evacuation zone and the sheltering zone were set. With the cooperation from all the related people such as police as well as local residents and local self-governing bodies etc., the evacuation and sheltering were carried out rapidly. On the other hand, due to the prolonged duration of the accident, the evacuation and sheltering were also prolonged. After that, to set the planned evacuation zone and emergency evacuation preparation zone, a decision to utilize the guidance of ICRP and IAEA was made quickly. Furthermore, the scope of the protection area set at this accident was considered as the area which should be improved as per the protection countermeasures and exceeded well over 8 to 10 km.</p> <p>For this, based on the experience of this accident, a structure should be set up to define the scope of wide area of evacuation at the time of nuclear disaster and guidance for radiological protection standards.</p>		<p>About the way of having a complete system for disaster prevention, it is under the jurisdiction of the government and hence no topic is raised in this industrial report.</p> <p>However, accompanying the review of plan of disaster prevention, the review of incident response program at the TEPCO side is to be considered as next investigation topic. Also, for, we would like to investigate how to handle those items which need adjustment with the government as well as self-governing bodies, and how to cooperate with them as enterprises, while checking the related points.</p>
Ensure basic safety	(23) Reinforce safety regulation administration system	<p>Since the administrative organizations, which are involved in nuclear safety assurance, are divided, it was difficult to identify those who had the primary responsibility to ensure sufficient safety work for the public to prevent disaster. Such safety operations include safety regulations as the primary regulatory body by the Nuclear and Industrial Safety Agency (NISA) of the Ministry of Economy, Trade and Industry, monitoring regulation of the primary administrative agencies by the Nuclear Safety Commission of the Cabinet Office, and the implementation of environmental monitoring by each Ministry and local governments involved in emergency operations. In addition, we must admit that the current system had a problem on swiftly responding a large-scale nuclear accident like this in a cooperative manner.</p> <p>For this, Nuclear and Industrial Safety Agency should be made independent of Ministry of Economy, Trade and Industry, and we should start the investigation of systems to implement environment monitoring and nuclear safety regulation administration with Nuclear Safety Commission and all the ministries.</p>		<p>Regulatory framework with respect to safety is under the jurisdiction of the government and hence no topic is raised in this industrial report.</p> <p>However, if there is a chance, we would like to participate in a discussion about the method for the desirable regulation, based on the lessons from this accident.</p> <p>About the way of having an organization on TEPCO side, for the incident response, the following countermeasures are specified.</p> <ul style="list-style-type: none"> • For some of the incident response operations of which judgment delay exert bad impact on the convergence of the accident, preparations should be made such as clarifying when to make judgment. This makes it possible to perform adjustment promptly with those outside the company and carry out operations rapidly. <ul style="list-style-type: none"> ■ Items mentioned in this report <ul style="list-style-type: none"> 4.10.6 organization/command, order ■ Examples of countermeasures <ul style="list-style-type: none"> Preparation related to emergency (29)
	(24) Maintaining and reinforcing the legal system, standards and guidelines	<p>The current accident raised many issues regarding the legal system and the related standards and guidelines for nuclear reactor safety and nuclear reactor disaster prevention. Moreover, based on the experiences of the current accident, the IAEA was expected to reflect these experiences in the standards and guidelines.</p> <p>Therefore, the review and maintenance of the legal system concerning the nuclear reactor safety and nuclear reactor disaster prevention and the related standards and guidelines is under progress. In this case, the countermeasures for high ageing of the existing facilities will have to be re-examined not only from the viewpoint of structural authenticity, but also from the viewpoint of the latest findings that include the advancements in system concepts. Furthermore, the orientation of regulation system backfitting, i.e., technical demands based on latest laws and new findings related to existing authorized facilities should become clear. Also, maximum contributions have to be made by providing related data so that the IAEA can reinforce its standards and guidelines.</p>		<p>Discussion on the reviewing guidelines is a basically regulator's task and hence no topic is raised in this industrial report. However, he or she should participate in discussing the guideline review by making positive recommendations of the items which needs to be reflected in industrial field. Also, going a step ahead of discussion, he or she should independently make feedbacks for those items that require measures. Furthermore, the establishment of industry guidelines is expected in the future, to ensure a constant level of voluntary support by the private sector.</p>
	(25) Ensuring well-qualified personnel for nuclear reactor safety and nuclear reactor disaster prevention	<p>In case of an accident along the lines that happened this time, along with experts who can respond to severe accidents, it is also necessary to have experts in the fields of nuclear reactor safety, nuclear reactor disaster prevention, crisis-management, and radiation medical treatment, etc. and to handle such events using the latest and best knowledge. Moreover, it is also necessary to not only focus on the current accident, but it is also extremely important to develop and promote personnel who are competent and well-qualified in nuclear reactor safety and nuclear reactor disaster prevention in order to ensure long and mid-term nuclear reactor safety work.</p> <p>Therefore, in addition to reinforcing the development of qualified personnel in educational establishments in the fields of nuclear reactor safety, nuclear reactor disaster prevention, crisis management, radiation medical treatment, etc., the talent development activities of nuclear reactor enterprises and regulatory bodies also need to be reinforced.</p>	<ul style="list-style-type: none"> • Aim for reinforcing the cooperation within the country as well as with educational establishments in order to build up a network of nuclear reactor experts. Reinforce the development of qualified personnel in regulatory agencies and specialized agencies, arrange for active employment of experts including public-private exchange, etc., and regularize the methods of experts in on-site and off-site response. 	<p>Until now, each company was engaged in ensuring the talent for its own company and the work of the entire industry as a whole was limited to some activities related to operating in-charge systems that were implemented by the Nuclear Power Technical Society. On the basis of the response conditions in the current accident and from the viewpoint of improving the nuclear power plant safety and nuclear reactor disaster prevention, it is necessary to study the important measures for developing qualified personnel for the entire industry and to build a systematic and broad-range talent development system.</p>
	(26) Ensuring impartiality	For ensuring the authenticity of safety system, multiplicity was been pursued so far, but	[Refer September 11, 2011 Government Report]	Based on the lessons learned from this accident, countermeasures

Group name	Items	Contents	Additional requirements in attachment data	Comparison with the measures of this report
	and diversity of safety system	<p>there was lack of response to avoid common cause failure, and sufficient impartiality and diversity could not be ensured.</p> <p>Therefore, for accurate handling of the common cause failure and further improvement of authenticity of safety functions, ensuring impartiality and diversity of safety system is reinforced.</p>	<p>For ensuring impartiality and diversity in the types and installation sites of emergency generators and seawater cooling systems, the plan is to reinforce ensuring impartiality and diversity of safety system in addition to the accurate handling of the common cause multifailure and further improvement of authenticity.</p>	<p>are examined from the point of multilayered protection, and concrete countermeasures are presented by taking into account impartiality and diversity.</p> <p>Loss of power and loss of heat sink are considered to be the common factors for failure. Although examples of concrete countermeasures against such factors are given, they are the countermeasures that have taken multiplicity and diversity into consideration.</p> <p>To be more specific, the countermeasures are described in '4.12 Summary of Countermeasures' as follows.</p> <ul style="list-style-type: none"> - Injection and Cooling <ul style="list-style-type: none"> • Flood prevention measures such as bulkhead etc. around the seawater pump • Deployment of seawater pump motor spare parts • Flood prevention countermeasures such as core spray system etc. of the establishment area related to the safety system • Deployment of movable seawater pump • Preparation of backup power for SRV drive and extra air container • Deployment of backup power for vent operation and driving source • Improvement in the authenticity of existing injection system by deployment of backup power supply vehicle or mass power supply • Flood prevention countermeasures of severe accident countermeasures system • Improvement in the authenticity with the flood countermeasures of severe accident countermeasures system • Portable power pump and hose etc. that are independent of existing systems • Ensuring water supply • Heat escape in air through containment vessel vent - Power supply <ul style="list-style-type: none"> • Install sea wall and breakwater in important safety equipment. • Flood prevention countermeasures of the important safety equipment in the establishment area • Flood prevention countermeasures such as improvement in the sealing of the opening such as air supply opening and penetration corresponding to the flood height • Water-tightness of the placement location of receiving transformer and switchyard or flood countermeasures of the equipment • Water-tightness of the installation area of the direct current power supply system or flood countermeasures of the equipment • Deployment of backup power supply vehicle or mass power supply, and improvement in the emergency procedures • Deployment of the direct power supply charging route with the backup power <p>■ Items mentioned in this report 4.12 Summary of countermeasures</p> <p>■ Examples of countermeasures Provisions against earthquake and tsunami (1)(2)(5)(7)(9) Corresponding to the loss of heat sink (1) to (3),(6),(8),(10) to (12) Power supply preparations (1) to (4)</p>
	(27) Effective utilization of the Probabilistic Safety Assessment Methodology (PAS) in the risk management	<p>It was found after systematic examination of the efforts taken to reduce the risks of the nuclear reactor power generation facility that PSA has not always been effectively used. In addition, quantitative evaluation of risks of the unusual events such as massive tsunami are very difficult also by using PSA, but with more uncertainty. The efforts that increases the authenticity has not been taken sufficiently by clearly specifying the uncertainty of such risks.</p> <p>Hereafter, apply the PSA again actively and promptly based on the opinion related to</p>		<p>Till now the deterministic plan and operations have been conducted, and it has been concluded that the accident will not occur by confirming that the accident will not occur with sufficient conservative conditions. As for this review, it is necessary to evaluate by the PSA though the probability is very low and it is also necessary to improve safety by checking for any event that can come to the cliff edge. One of them is the stress tests conducted under the guidelines of the</p>

Group name	Items	Contents	Additional requirements in attachment data	Comparison with the measures of this report
		the uncertainty and develop the safety improvement measures including effective accident management countermeasures based on that.		country, and as a result, upcoming new challenges are also taken into consideration. Regarding the efforts to PSA, it is necessary to work on the agenda for the future.
Bring about a culture of safety	(28) Bringing about a culture of safety	<p>All those involved in nuclear power generation should inculcate a safety culture. According to IAEA, 'Nuclear Safety Culture' means, 'The organization and individual should be prepared with the attitude of an integrated recognition, temperament and attitude to give priority according to the importance of nuclear safety issues.' According to our terms, it is a starting point, duty and responsibility of those involved in nuclear power generation. There is no constant improvement in nuclear reactor safety, if safety culture is not adopted.</p> <p>However, when compared with this accident, as nuclear operators of our country are those who bear the primary responsibility to ensure the safety along with the organizations and individuals, they have to look through all the new opinions, which confirms that whether it means vulnerability of own plant. When it was found to be affecting the hope of reducing the risk related to public safety of our plant, it is necessary to review if the sincere efforts had been taken to improve the safety measures.</p> <p>Similarly, as personnel who have the responsibility for ensuring nuclear safety for both organizations as well as individuals, the people involved in setting the nuclear power regulations for the country must show sensitivity and agility towards latest findings and opinions, without downplaying even the smallest of doubts related to ensuring safety. Therefore, it is essential to put the basic focus back on the absolute necessity for pursuing defense in depth for ensuring nuclear reactor safety in the future. The personnel involved in nuclear reactor safety must never neglect learning and gaining expert knowledge related to safety, and must work towards building a complete safety culture by always working to find out any weak points in the nuclear reactor safety and to find room for improving the safety.</p>	<ul style="list-style-type: none"> The country and enterprises need to work on establishing safety objectives of the organizations, and promotion, evaluation, improvement of activities for building a safety culture in individuals and organizations, reinforcing the cooperation with educational establishments and working towards developing qualified personnel for regulatory bodies. <p>[Government Report dated September 11, 2011] Both organizations and individuals involved in nuclear reactor enterprises and safety regulations are sincerely working on restructuring the professional attitude towards understanding and gaining new knowledge. Steadfast acquisition of a nuclear reactor safety culture by all organizations and individuals is the starting point for personnel involved in nuclear reactor safety and is their obligation and responsibility. Constant improvement in nuclear reactor safety in places where there is no safety culture is the starting point for ensuring future safety of our country and it needs to be reconfirmed and implemented through various formats.</p>	Following the JCO accident and concealment of troubles by Tokyo Electric Power Company, the nuclear power industry has been working honestly towards reinforcing the activities for developing a safety culture. The industry needs to reflect sincerely on why the accident at Fukushima Daiichi Nuclear Power Station could not be prevented and to review the methods related to safety culture. The industry should work on the future problems in having an ideal safety culture.

Appendix 5.2 Comparison of Recommendation of 12 items of NRC Japan Task Force with the countermeasures of this report

Item	Recommendation	Detailed requirements for electric power	Comparison with the countermeasures of this report
Clarification of regulatory framework	(1) A logical, systematic and consistent regulatory framework should be established to coordinate the defense in depth and risk consideration in a right way for adequate protection.	-	This is related to the concept of regulations and it is not raised as an issue in this report for industry.
Guarantee of protection	(2) NRC should re-evaluate the protection of each active reactor's SSC for earthquake and flood of design standards, and ask business operators to raise the standards if needed.	<p>○ According to the existing requirements and guidelines of NRC, earthquake and flood hazards on the premises should be re-evaluated and whenever required, the important security design standards and SSC which must be protected from updated hazards should be updated.</p> <p>○ A walk down preventive measure for earthquake and flood should be implemented, along with the specification and improvement in the plant specific vulnerability, the appropriateness of monitoring and preservation of the protection function such as temporary waterproof barrier and sheet should be verified until the long-term activity to update the design standards for outside events is completed.</p>	<p>For the evaluation of earthquake and tsunami, the following evaluation conditions are added based on the knowledge acquired from this data.</p> <ul style="list-style-type: none"> • Standard earthquake motion Ss design is considered as almost satisfactory as per the present way of thinking, but working of multiple earthquake centers is considered for further safety ensure. • At the time of evaluation of tsunami height which arrives along with the earthquake, hereafter the working of multiple earthquake centers is considered as a wave source at plate boundary and the necessity of setting the slip amount of earthquake source fault to a larger value is also verified at the same time. <p style="padding-left: 40px;">A possible tsunami height is evaluated, and protection is provided for the intrusion of tsunami on the premises. Further, the following multilayered measures are taken and security for the functions of safety equipment is provided.</p> <p style="padding-left: 40px;">Measures are taken for the intrusion on the premises due to invasion of tsunami. The concrete example is as follows.</p> <ul style="list-style-type: none"> • Attention is ensured for the arrangement of power-supply system important to safety, and provided with the intrusion due to tsunami, the storm surge barrier (flood barrier) or breakwater should be set or the protection barrier should be set on important equipment from the viewpoint of multi-tiered protection. • Protection against tsunami such as tank responsible for problem like a sea wrack at emergency response (protection barrier etc.). Deployment of heavy equipment to remove a sea wreck. <p>Further, measures are taken for the protection against intrusion in the building. The concrete example is as follows.</p> <ul style="list-style-type: none"> • For a tsunami which exceeds the assumption, intrusion prevention measure such as improvement in the sealing of opening and penetration area of the outside door or air supply opening of a building as per tsunami height is implemented. • For a tsunami which exceeds the assumption, measures are taken such as improvement in water-tightness of the door necessary to prevent the intrusion in equipment important to safety, and the impact of instruction is determined. • For the early restoration, a portable drainage pump is

Item	Recommendation	Detailed requirements for electric power	Comparison with the countermeasures of this report
			<p>arranged to pump out the seawater entered in the building.</p> <ul style="list-style-type: none"> • About the impact of wave power of tsunami, places where there is a direct impact of tsunami at the outside door facing the sea are considered. <p>Also, measures for flooding from tsunami are taken for the seawater pump.</p> <ul style="list-style-type: none"> ■ Relevant section in this report 4.6 Preparation for earthquake or tsunami ■ Example of countermeasure Preparation for earthquake tsunami (1) to (5), (7), (10), (11)
	(3) As a part of long-term re-examination, a possibility of capacity building to prevent or mitigate the earthquake fire and overflow stream must be evaluated.	-	Fire protection measures have already been implemented for the fire. And for the internal overflow stream, investigation is in progress as a part of earthquake response of Kashiwazaki Kariwa. But, combining with the earthquake, hereafter it is necessary to continue working on the investigation of measures for composite events.
Strengthening mitigative capacity	(4) For the design standards and non-design standards outside events, SBO mitigative capacity of all the active reactors and new reactors should be strengthened.	<p>○ Rulemaking to revise 10 CFR 50.63 should be started, and for the business operators of active reactors as well as new reactor, (1) Response time of minimum 8 hours should be verified for the station blackout, (2) The equipment, procedure and training required to implement the response time of 72 hours during "Station blackout extension" for the reactor core and cooling of spent fuel pool, or integrity of reactor cooling system and primary containment as required, should be established, and (3) External traffic infrastructure function related to the large-scale natural disasters should include the capacity to acquire equipment in the given time for response capacity building under significantly reduced conditions, and persistent cooling capability of the reactor core and spent fuel pool on the premises or the external resource to support the integrity of reactor cooling system and primary containment system as required, should be planned and prepared in advance.</p> <p>○ According to 10 CFR 50.54(h)(2), currently provided equipment should be rationally protected from outside events in terms of design standards which together with other requirements are to be revised and implemented. In this way, the Station shall handle events at multiple reactors by adding equipment as required.</p>	<p>From a power supply security viewpoint, first when the secured external power supply was not good, the equipment was already installed to supply the power by emergency DG. However, this time the equipment did not work due to the loss of function.</p> <p>Therefore, first it is necessary to improve the reliability of the external power supply.</p> <p>[1] The external power supply is based on NISA instructions document "About ensuring reliability of external power supply for nuclear power plant and reprocessing plant," and corresponds to the measures to ensure the reliability of power supply (circuit connection, steel tower strengthening, switchyard intrusion measure).</p> <p>Next, preparation is done for DC power supply by assuming the loss of function of emergency DG.</p> <p>[2] As a backup power supply of emergency D/G, diversification of power supply is provided by deploying the power supply vehicle or power supply with large capacity (including the required fuel). The power panel is prepared for a tsunami invasion by taking intrusion countermeasures. Further, a power supply vehicle is placed in an elevated location where there is no tsunami impact.</p> <p>And for DC power supply, countermeasures are taken separately to avoid any loss of power.</p> <p>[3] Battery secures the charging route from backup power supply and also is ready for a tsunami invasion by intrusion countermeasures.</p> <p>Good power supply security is achieved by taking these multilayered countermeasures.</p> <p>The following countermeasures are taken to secure the functions of cooling system.</p> <p>[1] Security of measures to inject water into the reactor with a portable power pump independent of the existing power supply, security of water source for injection including seawater, and depressurization of a good reactor by SRV is necessary for injection. In this way, the Station secures a good injection cooling function to the reactor by securing the backup drive force necessary for SRV operation.</p> <p>[2] Security of alternate ultimate heat sink to handle heat escape to the air by container vent.</p> <p>[3] Early restoration of seawater pump or arrangement of spare parts makes it possible to secure ultimate heat sink by restoration of seawater system.</p> <p>It is not necessary to set a time by which to take these countermeasures. Training is conducted by considering the time from functional loss of equipment of safety system to the core damage. And the countermeasures are deemed to be acceptable by confirming whether an alternative measure is ready before the core is damaged.</p> <p>Further, basically all the necessary equipment are placed inside the power plant.</p>

Item	Recommendation	Detailed requirements for electric power	Comparison with the countermeasures of this report
			<p>Refer to item (7) for cooling of spent fuel pool.</p> <ul style="list-style-type: none"> ■ Relevant section in this report <ul style="list-style-type: none"> 4.7 Preparation for power supply 4.8 Heat sink loss response ■ Recommended example of countermeasure Preparation for power supply [1] to [6] Heat sink loss response [1], [2], [8] to [11]
	(5) Pressure vent design should be used for a BWR provided with Mark type I and Mark type II containers.	○ A reliable pressure vent should be installed in a BWR provided with Mark I type and Mark II type containers.	<p>Not only for the installation of a pressure vent, but also to secure a good vent function, following can be suggested as an example of a countermeasure for line configuration.</p> <p>[1] In case of loss of the existing drive source, it is advised to secure a backup drive source (power supply or pump) which is required to operate the container vent valve.</p> <p>And the vent operating procedure will be considered hereafter, by taking into consideration the possibility of overtemperature failure.</p> <p>[2] Investigation will proceed for “Optimization of operating conditions of vent” and “Preventive measures for the leakage (wraparound) to neighboring unit from vent exhaust line.”</p> <p>[3] Further, investigation is carried out as a countermeasure for cooling by container alternate spray after core damage.</p> <ul style="list-style-type: none"> ■ Relevant section in this report <ul style="list-style-type: none"> 4.8.3 Container vent 4.9 Hydrogen measure ■ Example of countermeasure <ul style="list-style-type: none"> Heat sink loss response [1], [3] to [5] Hydrogen measure [3]
	(6) Hereafter with the disclosure of additional information by future investigation of an accident occurred in Fukushima Daiichi Nuclear Power Station, a vision should be determined for mitigation and hydrogen control in the container and in the building as a part of long-term re-examination.	-	<p>Hydrogen may be generated due to the oxidizing reaction between the reactor coolant and fuel cladding. So, based on the past design basis events, the atmosphere in the reactor containment is made below the fuel limit by preventing the hydrogen generation by core cooling such as emergency core cooling system or by creating inert gas environment by nitrogen sealing to reactor containment in the boiling water reactor (BWR) even though the hydrogen is generated suddenly. However, when hydrogen is generated in the same container of BWR and design conditions are exceeded, the hydrogen will leak inside the reactor building. Hence, [1] “Countermeasure to release or reduce the hydrogen retained inside the reactor building” and [2] “Installation of hydrogen gas detector to properly monitor the retention of hydrogen in the reactor building, along with the investigation of a channel where the hydrogen leaked inside the reactor building” are recommended. Moreover, during container vent in severe accident management response, [3] “Prevention of hydrogen wraparound from the ventilation pipe when a branch pipe is placed in the container vent line” and [4] “Prevention of hydrogen wraparound to other units sharing the vent stack” are recommended to prevent the wraparound of hydrogen inside the reactor building, and we are trying to prevent the accumulation of hydrogen inside the reactor building.</p> <p>In this way, for hydrogen which may be generated in the reactor core, an explosion in the reactor building due to the accumulation of hydrogen can be prevented, stopping extension of the accident, by taking the above countermeasures.</p> <p>Further, a hydrogen explosion can be prevented by ensuring the Station takes action to prevent hydrogen generation and takes release countermeasures without fail. Hence it is not necessary to install a flammable gas control system in the reactor building in BWR.</p> <ul style="list-style-type: none"> ■ Relevant section in this report <ul style="list-style-type: none"> 4.9 Hydrogen countermeasure ■ Example of countermeasure <ul style="list-style-type: none"> Hydrogen countermeasure [1] to [4]
	(7) Condenser capacity and instrumentation of	○ Enough safety system instrumentation which can withstand natural	In the security of a reliable cooling function of a spent fuel pool, it is extremely

Item	Recommendation	Detailed requirements for electric power	Comparison with the countermeasures of this report
	spent fuel pool should be strengthened.	<p>phenomenon of design standards, and can be monitored from the control room of important parameters (water level, temperature and area radiation level) of spent fuel pool should be provided.</p> <p>○ Safety system AC power supply should be provided to the makeup system of spent fuel pool.</p> <p>○ Technical specifications should be revised so that the demand to provide operable one house emergency power supply train for the makeup and instrumentation of spent fuel pool is fulfilled, irrespective of the operation mode of a reactor, when there is irradiated fuel in the spent fuel pool.</p> <p>○ Already installed equipment to spray the water on the spent fuel pool which is confirmed after considering the earthquake should be provided including the connection where the access to water supply is easy on the same plane as external building (by using the portable pump or pump train).</p>	<p>important that the water level in the pool is maintained even if the cooling function is lost and the spent fuel is not exposed. For that, securing an alternative injection measure is important. For example, countermeasures such as injection by fire engines or pump cars and together the security of injection route and water source can be considered.</p> <p>Moreover, it is necessary to intensify the monitoring function of pool water level and pool water temperature to check the validity of alternate injection measure. For example, a power supply to the level instrumentation and thermometer from emergency power supply or monitoring enhancement of pool using battery drive ITV can be considered as countermeasures.</p> <p>In this way, the integrity of the spent fuel can be secured by maintaining the pool water level by injection to the spent fuel pool, but this can also be raised as an example of a countermeasure to further improve reliability or a measure to maintain the cooling function.</p> <p>In the Fukushima Daiichi Nuclear Power Station, where all the power supply is lost, it is thought good enough from the viewpoint of fuel damage prevention, if water can certainly supplied by temporary equipment, rather than making a power supply of a permanent makeup water system as safety system. (Therefore, it is not necessary to revise the technical specifications.)</p> <ul style="list-style-type: none"> ■ Relevant section in this report 4.11 Integrity security of spent fuel ■ Example of countermeasure Integrity security of spent fuel [1] to [3]
	(8) The ability to respond during emergency in the facilities such as plant Emergency Operation Procedure (EOP), Severe Accident Management Guideline (SAMG) and EDMG must be strengthened and integrated.	<p>○ Technical guidelines (supplement 1 “Requirements for emergency response ability” for NUREG-0737 in GL 82-33) for plant emergency operation procedure must be revised so as to (1) include the plant emergency operation procedure, severe accident management guidance and EDMG in an integrated format, (2) specify precise command and control strategy related to the implementation and (3) grant itable qualifications and provide training to the staff who make a decision during emergency.</p> <p>○ Section 5.0 “Administrative control” of standard technical specifications to refer to technical guidelines for plant emergency operation procedure approved for plant in each reactor operation design must be revised, and the technical specifications of each plant must be revised so as to comply with those changes.</p>	<ul style="list-style-type: none"> • Countermeasure is taken such as installation of equipment by considering all power supply loss or heat sink loss, and measures are also raised for making the procedure for that. • As a countermeasure related to the organization/command or order, for items that are badly affected by accident convergence due to delay in the judgment, the timing of judgment is clarified, and external adjustment is carried so that the operation can be done quickly. And a countermeasure to build up a communication facility is also raised. In the emergency station, securing a means to collect the plant parameters required for command is also raised as a countermeasure. <p>Qualifications are not demanded officially, but Station workers should seek to secure aknowledge and techniques as a part of their training.</p> <ul style="list-style-type: none"> ■ Relevant section in this report 4.7 Preparation for power supply 4.8 Heat sink loss response 4.10.1 Training 4.10.4 Emergency Station 4.10.6 Organization/command or order 4.10.7 Communication ■ Example of countermeasure Preparation for power supply [1], [4] Heat sink loss response [1], [3], [4], [6], [8] to [10] Preparation for emergency [14] to [19], [24], [28], [29], [31] to [33]
Strengthening emergency response	(9) NRC should request the summary to respond to long-term station blackout (SBO) and multiple unit events in facility emergency countermeasures.	<p>○ The following points should be implemented until rule making activity is completed.</p> <ul style="list-style-type: none"> • Determination of workers to fulfill all the positions required to respond to multiple unit events and its implementation. 	<ul style="list-style-type: none"> • Countermeasure is taken such as installation of equipment by considering all power supply loss or heat sink loss, and measures are also raised for making the procedure for that. • Countermeasures are raised for strengthening of communication equipment or emergency response for

Item	Recommendation	Detailed requirements for electric power	Comparison with the countermeasures of this report
		<ul style="list-style-type: none"> • Addition of guidelines in the documented emergency plan for the implementation method of multiple unit dose evaluation (including the discharge from spent fuel pool) using the dose evaluation software and approach specialized for the facility given by business operator. • Implementation of periodical training and practice for multiple units and long-term SBO scenario. Exercise related to the identification and acquisition of non-institutional resources within the possible range (simulate). • Assurance about the fact that facilities and equipment for emergency response will properly deal with the scenario of multiple units and long-term SBO. • Power supply measures to communication equipment required for the communication within the plant (wireless communication between the response team and the plant etc.) as well as outside the plant (cellular phone, satellite phone etc.) during long-term SBO. • Maintenance of capacity of emergency response data system throughout the accident occurrence period. <p>○ To secure the monitoring capability of multiple units, initiative to bring the emergency response data system to the latest state needs to be completed before June 2012.</p>	<p>system, instrument and monitoring. Its validity will be checked through training.</p> <ul style="list-style-type: none"> • Implementation of training is raised as a countermeasure. Whether the preparation to respond to multiple units is done will be checked through training, and as a result, re-examination such as strengthening of system will be carried out if required. • Provision of disaster control measures and building a cooperative system during emergencies are taken as measures for resources. <ul style="list-style-type: none"> ■ Relevant section in this report <ul style="list-style-type: none"> 4.7 Preparation for power supply 4.8 Heat sink loss response 4.10.1 Training 4.10.7 Communication 4.10.8 Environmental monitoring ■ Example of countermeasure <ul style="list-style-type: none"> Preparation for power supply [1], [4] Heat sink loss response [1], [3], [4], [6], [8] to [10] <p>Preparation for emergency [13] to [20], [30] to [43]</p>
	<p>(10) As a part of long-term review, NRC should search for additional themes to emergency response, which are related to multiple unit events and long-term SBO.</p>	<p>○ <i>Based on the insights taken from Fukushima Daiichi Nuclear Power Station accident, analysis should be carried out for emergency responder about the requirements and guidelines related to the current security equipment.</i></p> <p>○ <i>About long-term SBO or multiple unit events or both, to secure the existence of proper level authority and monitoring system in a proper plant, evaluation should be carried out for command and control formulation as well as qualifications of the decision-maker.</i></p> <p>○ <i>Emergency Response Data System (ERDS) is evaluated by using the following methods.</i></p> <ul style="list-style-type: none"> • Alternative methods (such as satellite connection) are determined to send the data of emergency response data system, which is independent of the fixed-line infrastructure which may not be useful during large scale natural disaster. • Currently received data set in various locations determines whether the conditions necessary in the updated evaluation are fulfilled. • During emergency, whether the emergency response data system should continuously send the data so that the operator need not perform it is determined. 	<ul style="list-style-type: none"> • As a countermeasure related to the organization/command or order, for items that are badly affected by accident convergence due to delay in the judgment, the timing of judgment is clarified, and external adjustment is carried in an early stage so that the operation can be done quickly. And a countermeasure to build up a communication facility is also raised. In the emergency station, securing a means to collect the plant parameters required for command is also raised as a countermeasure. • Qualifications are not demanded officially, but Station workers should seek to secure a knowledge and techniques as a part of their training. <ul style="list-style-type: none"> ■ Relevant section in this report <ul style="list-style-type: none"> 4.10.1 Training 4.10.7 Communication ■ Example of countermeasure <ul style="list-style-type: none"> Preparation for emergency [14] to [19], [24], [28], [29], [31] to [33]
	<p>(11) As a part of long-term review, NRC should search for emergency response related to decision-making, radiation monitoring and promotion of citizens.</p>	<p>○ <i>Investigation should be carried out by emergency response resources within the plant about whether it is necessary to effectively implement the emergency response such as capacity to transport equipment to the site, when there is no support from outside the plant or the support is delayed since the infrastructure outside the plant is destroyed due to the extensive natural disaster or there are other priorities for response resource.</i></p> <p>○ <i>Insights obtained from the implementation of emergency response in</i></p>	<p>Country and the local government have carried out the monitoring at the time of accident and publicized the results, and power companies will cooperate with that system. In response to this accident, investigation for accident response such as monitoring is proceeding in the country, but voluntary measures are taken regarding cooperation for the power companies.</p> <p>Specifically, countermeasures are implemented for the following items.</p>

Item	Recommendation	Detailed requirements for electric power	Comparison with the countermeasures of this report
		<p><i>Fukushima should be evaluated.</i></p> <p><i>○ Validity (including consideration about independence from AC power supply, availability of real-time internet) of radiation monitoring within the plant and in the range of emergency planning zone in real-time should be investigated.</i></p> <p><i>○ Training about radioactivity, its safety and correct dose method of KI should be implemented in a local community around each nuclear power plant.</i></p>	<ul style="list-style-type: none"> - Monitoring equipment required in advance for emergency, reconfirmation of equipment and their deployment as required - Re-examination of the supporting staff necessary during emergency and upgrading the rules related to their dispatch - Strengthening of power supply and transmission line - Buildup resistance for earthquake and tsunami - Re-examination of the test procedure by alternative measures such as temporary monitoring equipment - Information to send, its compilation method and arrangement of the required staff - Review of means of communication (press, HP etc.) or announcement timing <ul style="list-style-type: none"> ■ Relevant section in this report 4.10.8 Environmental monitoring ■ Example of countermeasure Preparation for emergency time [34] to [40]
Efficiency improvement of NRC program	(12) NRC should strengthen the regulatory monitoring for a safety record (that is, reactor oversight process) of a business operator, by keeping the focus on requirements to defense in depth which conform to the recommended defense in depth framework.	<i>○ To include the consideration of defense in depth completely, annual self-assessment of reactor oversight process and reorganization of reactor oversight process every 2 years should be implemented.</i>	This is not raised as an issue in this report for industry as it is a regulator's approach. Further, hereafter in the peer review carried out by WANO or JANTI, EP or SAM will also be tackled as review items.

(Note) Text written in italic is the countermeasure which may relate to both regulations as well as business operator.

Appendix 6 MARK-I Containment

Various arguments have been raised concerning the MARK-I Containment. We will summarize the industry's opinions on the MARK-I Containment as below.

With regard to the details of the arguments, please access General Electric Co. website (http://www.ge.com/jp/docs/1307504328207_NEI_Report.pdf) to read the explanations.

Primarily, MARK-I containment has been designed to have sufficient strength by being compliant to various design requirements including the seismic resistance. Further, the recent engineering findings have been integrated in the facilities at each stage. Accordingly, the safety performance of the MARK-I containment is judged as equivalent at least to the other containment models.

The points raised as targets of arguments are the four items as below:

1. The containment is vulnerable to earthquakes
2. Because of small containment capacity, the capacity for absorbing the energy discharged from the core in the event of accident is low.
3. The containment is likely to be damaged when dynamic load is applied to the inner wall of its suppression chamber in the event of disasters such as an earthquake.
4. Containment Failure Probability is high when a severe accident is assumed.

Our opinions on these points are indicated below.

1. Earthquake-resistant performance of MARK-I Containment

MARK-I Containment has following characteristics:

- A suppression chamber is arranged on the side of RPV.
- Its center of gravity is low, because low containment can be made.
- Its center of gravity is low, because the position to arrange RPV in the containment is low.

In MARK-I Containment, height of the facility can be made low by arranging the suppression chamber on the side of PRV. At the same time, it contacts the ground with a wider area.

Accordingly, the MARK-I is considered as an advantageous containment type in terms of aseismic design.

A comparison of MARK-I Containment and MARK-II Containment is indicated in Figure Appendix 6-1.

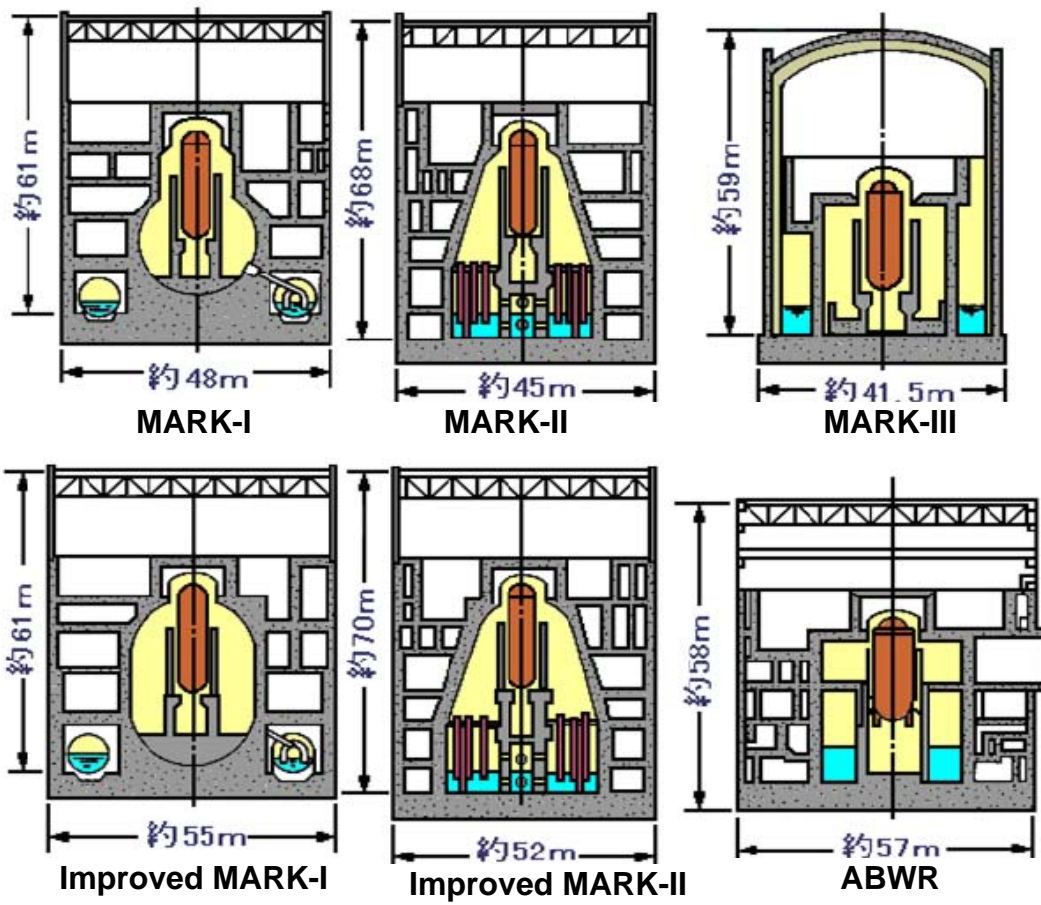

Figure Appendix 6-1

2. Capacity of MARK-I Containment

The energy discharged in the event of an accident is proportional to the thermal output of the reactor. Comparing the proportion of reactor containment capacities that absorb the energy, the proportion of MARK-I Containment is higher than those of MARK-II containment or RCCV. While the capacity of the MARK-I Containment is smaller, it shows an equivalent level of energy absorption to the energy absorption in other models in terms of absorption of energies discharged from the core in the event of an accident.

Table Appendix 6-1 indicates the average containment space volume and the average reactor thermal output in MARK-I Containment and the other types of containments.

Table Appendix 6-1 Containment space volume versus thermal output

Containment type	Average containment space volume [m ³]	Average reactor thermal output [MW]	Containment space volume ÷ thermal output [m ³ /MW]
MARK-I	6,558	1,681.8	4.10
Improved MARK-I	12,500	2,581.2	4.95
MARK-II	9,775	3,293	2.96
Improved MARK-II	14,406	3,293	4.37
RCCV	13,355	3,926	3.40

3. Dynamic load to suppression chamber pool

Following two conditions are considered to generate pressure on internal wall of the suppression chamber in the arguments.

- (1) Earthquake
- (2) Steam discharge from SRVs

(i) Earthquake

As indicated below, dynamic load by an earthquake is not a MARK-I Containment-specific problem.

Following two items are the key points in the arguments:

- Sloshing of pool water caused by an earthquake generates a dynamic load on the internal wall of suppression chamber.
- Sloshing of pool water caused by an earthquake results in exposure of steam exhaust pipes from SRVs to the suppression chamber space. If this event occurs concurrently with a loss of reactor coolant accident, steam from RPVs is discharged directly to the suppression chamber space. This may elevate the pressure inside the suppression chamber.

The dynamic load generated by sloshing of pool water under the impact of an earthquake has been confirmed to have no negative impact based on the structural analysis. With regard to the SRV exhaust pipes, the exhaust pipes should not come above the water level, even if the water level of the suppression pool is the lowest and considering the point where amplitude of

the pool water sloshing is the maximum. Therefore, it is confirmed that the event which may be raised in the arguments never occurs.

(ii) Impact of steam discharge from SRVs

A countermeasure has been implemented against the dynamic load through the SRV steam applied on internal wall of the suppression chamber. Therefore, it does not constitute a problem specific to MARK-I Containment.

When an internal pressure of RPV elevates, SRVs are actuated to discharge RPV steam into the water of suppression chamber pool with the purpose to prevent damage on the RPV.

In this occasion, the possibility of applying a local dynamic load on internal walls of suppression chamber has been pointed out due to local discharge of the steam.

To address this issue, an improvement was conducted so that the steam exhaust pipe should be located on the cross-type nozzle instead of a straight nozzle. In this configuration, the steam is distributed and discharged into the water (quencher type). Based on this modification local pressure can be avoided.

4. Security of containment integrity based on the assumption of a severe accident

Each operator carried out the probabilistic safety assessment (PSA), identified and implemented valid countermeasures against the severe accidents. Integrity of the containment in the event of severe accident is secured based on this process.

Following two factors are identified as causes of the containment damage:

- Pressure that exceeds maximum operating pressure of the containment
- Temperature that exceeds maximum operating temperature of the containment

Following four countermeasures have been examined and implemented to maintain integrity of the containment by eliminating the aforementioned damage factors.

1. Containment vent
2. Alternative coolant injection
3. Containment spray
4. Alternative cooling

Reference 1 Station Overview

Station overviews for the Units 1 to 3 of Fukushima Daiichi Nuclear Power Station are indicated in Table Reference 1, Figure Reference 1-1 and Figure Reference 1-2. Further, the outlines of severe accident countermeasures already implemented in the Units 1 to 3 are indicated in Table Reference 2 and from Figure References 1-3 through Figure Reference 1-8.

Table Reference 1-1 Station overview

Station	Unit 1	Unit 2	Unit 3
Reactor type	BWR3	BWR4	BWR4
Containment type	Mark-I	Mark-I	Mark-I
Thermal output (MWt)	1,380	2,381	2,381
Power output (MWe)	460	784	784
Fuel assembly #	400	548	548
Control rod #	97	137	137
Safety relief valve	4	8	8
Safety valve	3	3	3
Emergency condenser (Heat exchanger #)	2	—	—
Cooling system at isolation (Pump #)	—	1	1
Emergency core cooling system (Pump #)	HPCI:1 CS:4 ADS	HPCI:1 CS:2 LPCI:4 ADS	HPCI:1 CS:2 LPCI:4 ADS
Containment cooling system / Residual heat removal system	—	2	2
Containment cooling system (Pump #)	4	—	—
Shutdown cooling system (Pump #)	2	—	—
Emergency DG (Unit #)	2	2	2
Containment capacity	DW: 3,410 m ³ WW: 2,620 m ³ SP: 1,750 m ³	DW: 4,240 m ³ WW: 3,160 m ³ SP: 2,980 m ³	DW: 4,240 m ³ WW: 3,160 m ³ SP: 2,980 m ³

Table Reference 1-2 Countermeasures implemented for severe accident

Function	Countermeasure for severe accident	Unit 1	Units 2 and 3
Reactor shutdown function	Recirculation pump trip (RPT)	○	○
	Alternative control rod insertion (ARI)	○	○
Coolant injection to reactor and containment	Alternative coolant injection (Coolant injection to reactor and containment by using condensate water makeup system and fire extinguishing pump etc.)	○	○
	Automatic actuation of reactor depressurization (Addition of ADS interlock)	—	○
Function to remove heat from containment	Alternative heat removal (Positive use of DW cooler and reactor coolant cleanup system)	○	○
	Restoration of failed component of residual heat removal system (Procedure)	○	○
	Pressure resistant reinforced vent	○	○
Function to support safety features	Additional installation of emergency D/Gs (2 dedicated DGs for each plant)	○	○
	Interchange of power supply (480 V is made available by adjacent plant)	○	○
	Restoration of failed component of emergency D/Gs (Procedure)	○	○

What is the countermeasure against severe accident (i.e., accident management)?

A countermeasure against severe accident (i.e., accident management) means a countermeasure to prevent development of an event that may lead to a severe accident (i.e., a large scale accident that may result in a serious damage of reactor fuels) as well as a countermeasure to mitigate the impacts of a severe accident even if the event should develop into a severe accident.

In May 1992, the Nuclear Safety Commission made recommendations on the accident management for severe accidents, and in July, the government requested each electric utility to implement an accident management. In these recommendations, electric utilities are requested to make voluntary commitments to reduce accident risks and to enhance safety, although it is admitted that no additional safety regulations are necessary because the safety in the domestic nuclear power plants has been sufficiently guaranteed by currently available safety measures.

Upon receiving these recommendations, electric utilities have implemented their own accident management measures and a report summarizing the contents of these measures was submitted to the government in May 2002. The Nuclear Safety Commission reviewed the report and evaluated that the countermeasures developed by electric utilities were appropriate.

In the accident management, a situation is assumed where abnormality (or abnormalities) occurred and the entire emergency core cooling system (ECCS) failed. In such a situation, some special countermeasures are taken such as pumps normally used for fire extinguishing are used to inject coolant to the core for cooling the fuels. In the accident management, it is necessary to make most of the components originally used for some other functions to address an abnormal situation so as to prevent development of the event and to mitigate its impacts.

Accident management is also a requirement in IAEA standards.

IAEA NS-G-2.15 SEVERE ACCIDENT MANAGEMENT PROGRAMMES FOR NUCLEAR POWER STATIONS

1.4. Accident management is the taking of a set of actions during the evolution of a beyond design basis accident:

- (a) To prevent the escalation of the event into a severe accident;
- (b) To mitigate the consequences of a severe accident;
- (c) To achieve a long term safe stable state [4].

The second aspect of accident management (to mitigate the consequences of a severe accident) is also termed severe accident management. Accident management is essential to ensure effective defense in depth at the fourth level

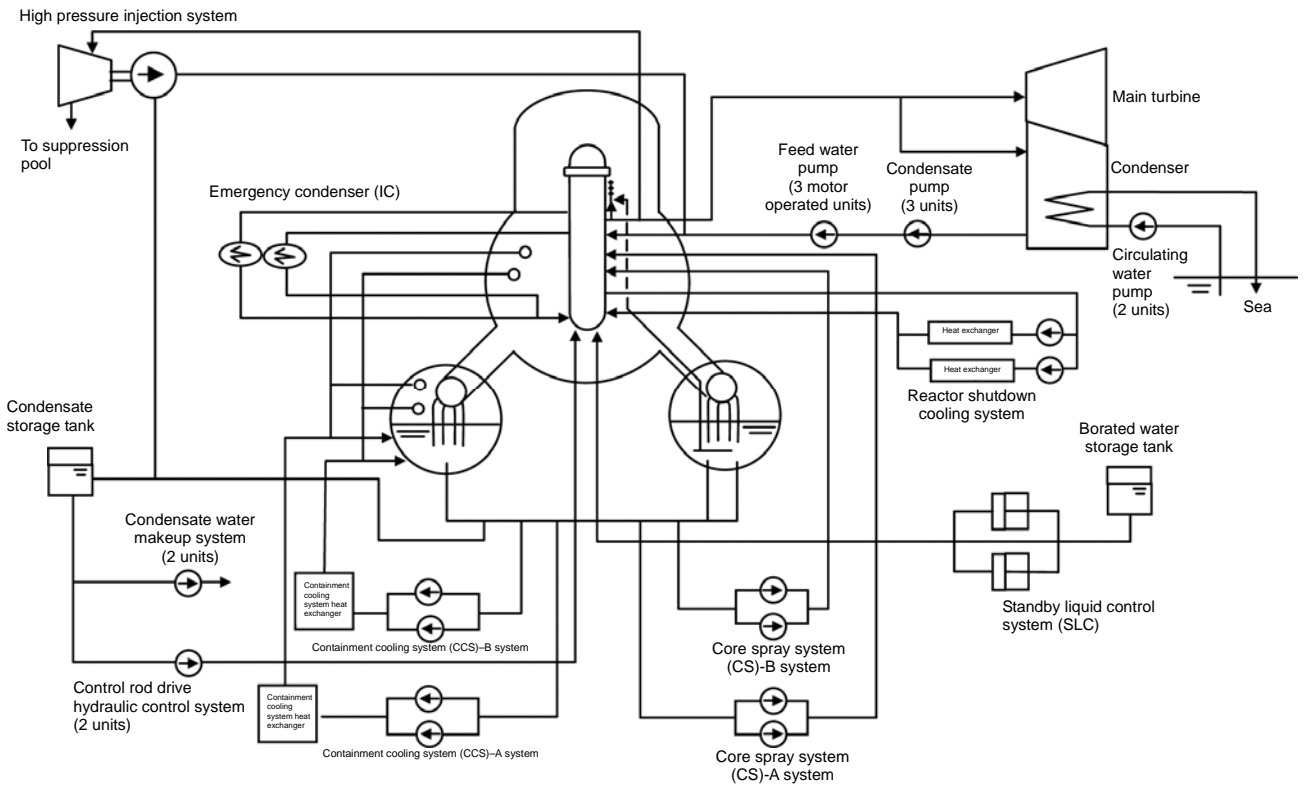

Figure Reference 1-1 Station overview (Unit 1)

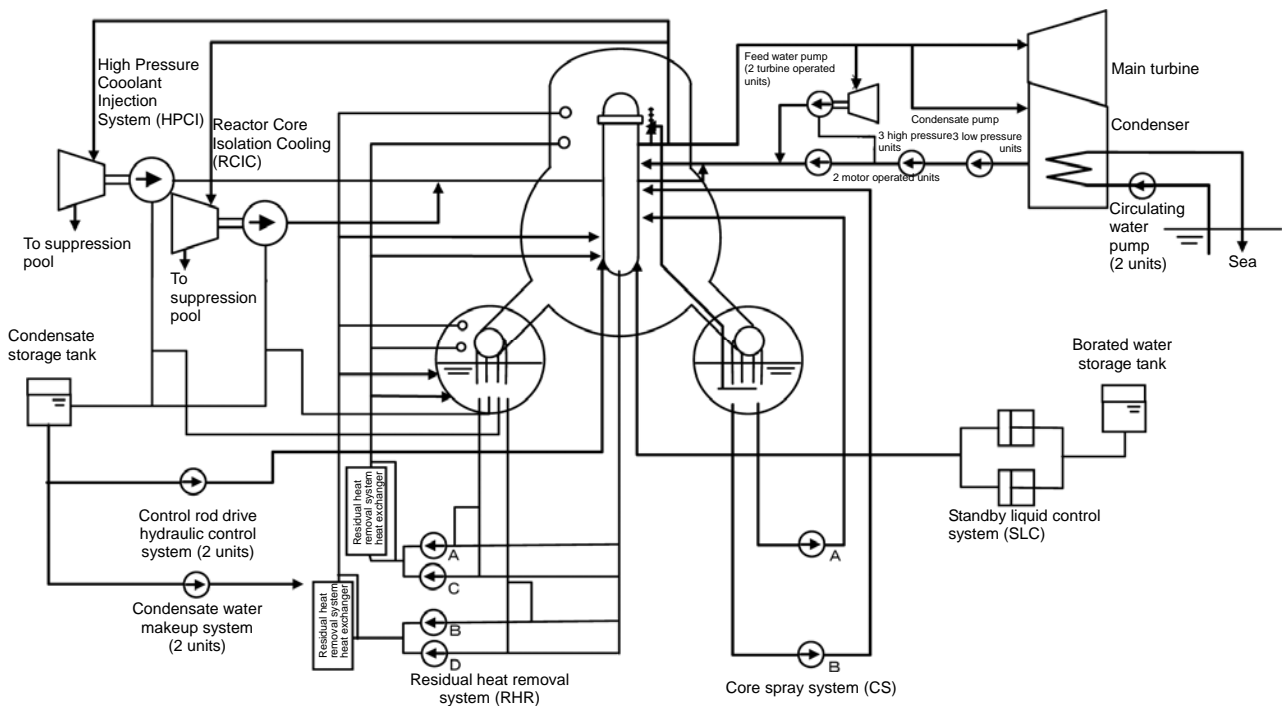

Figure Reference 1-2 Station overview (Units 2 and 3)

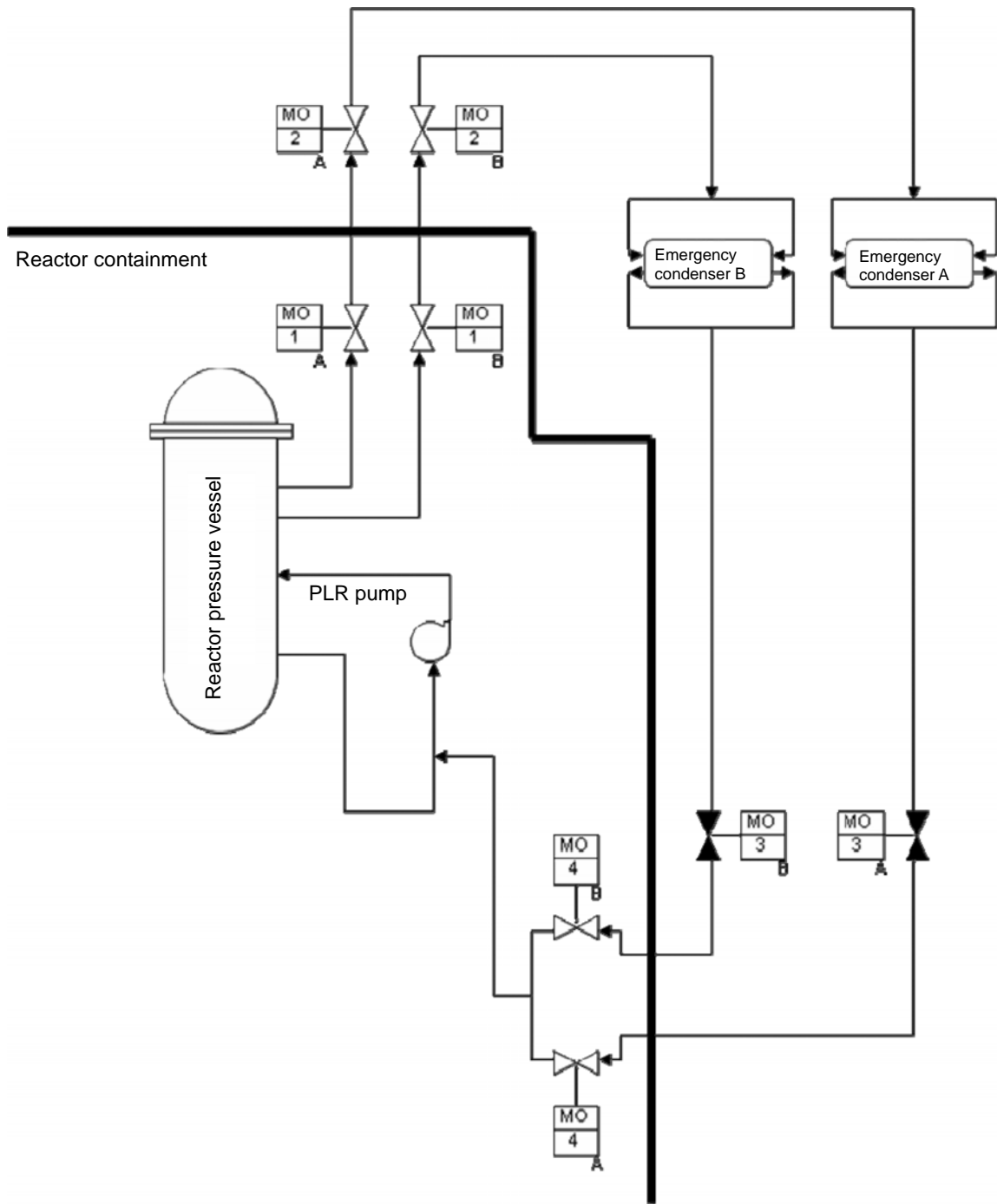

Figure Reference1-3 Emergency condenser

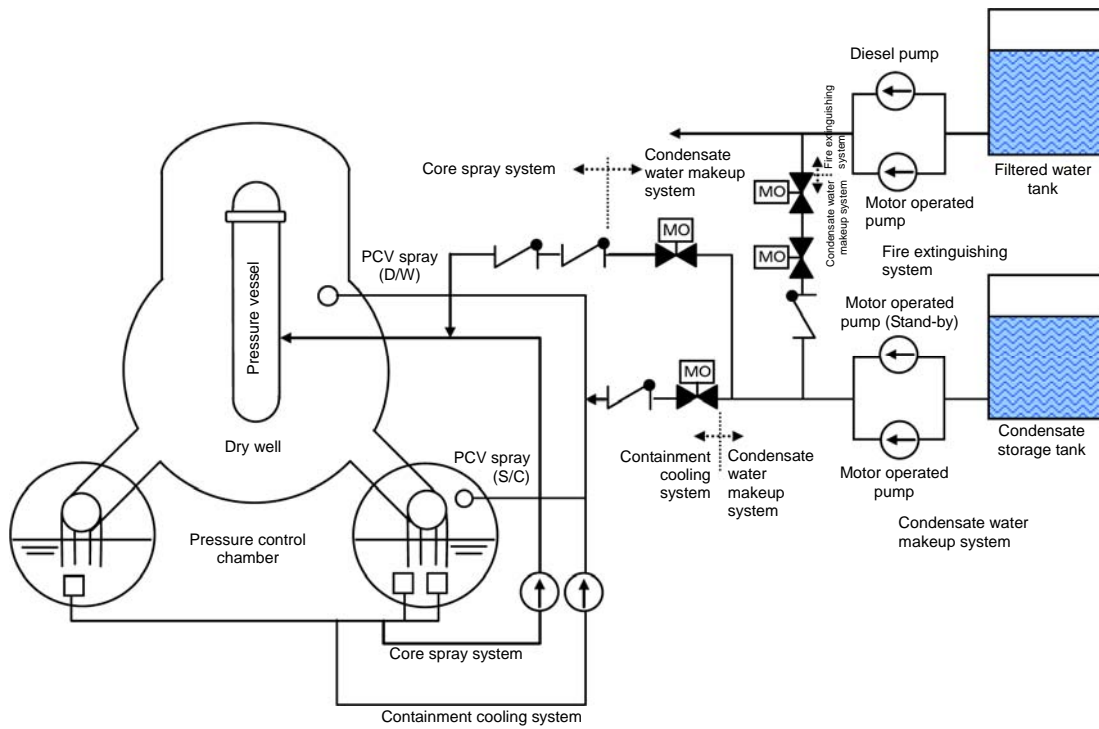

Figure Reference 1-4 Alternative coolant injection system (Unit 1)

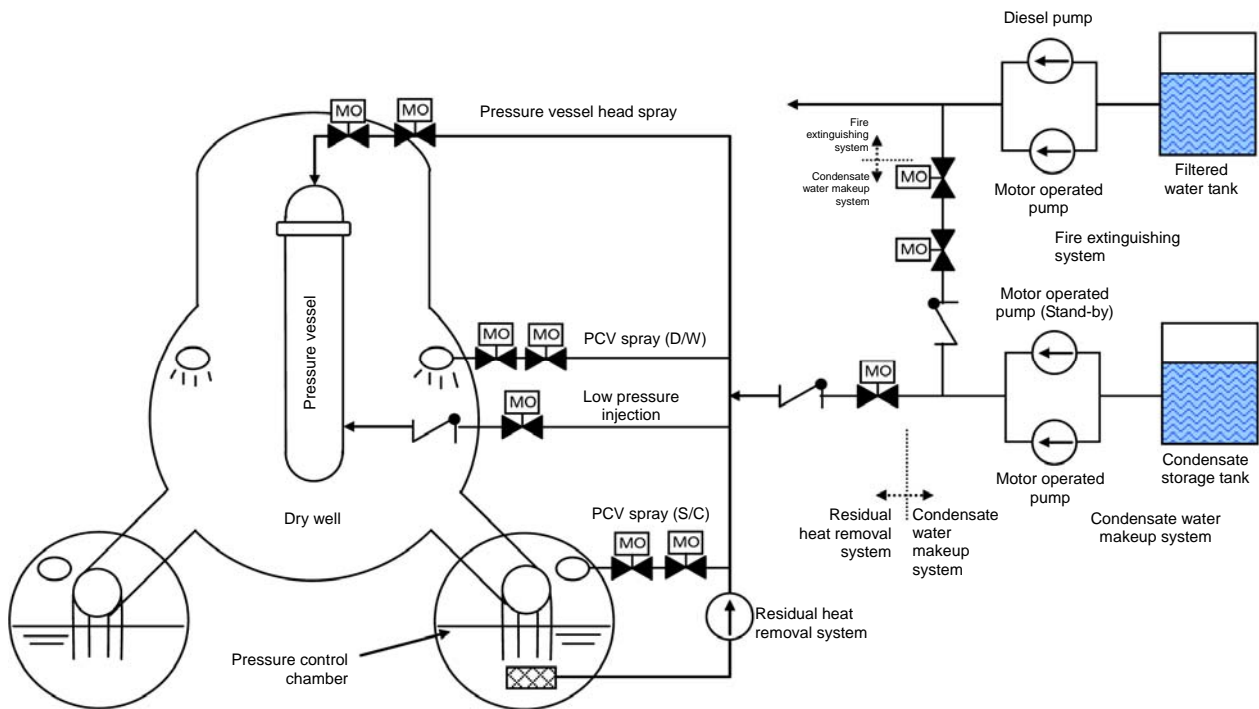

Figure Reference 1-5 Alternative coolant injection system (Units 2 and 3)

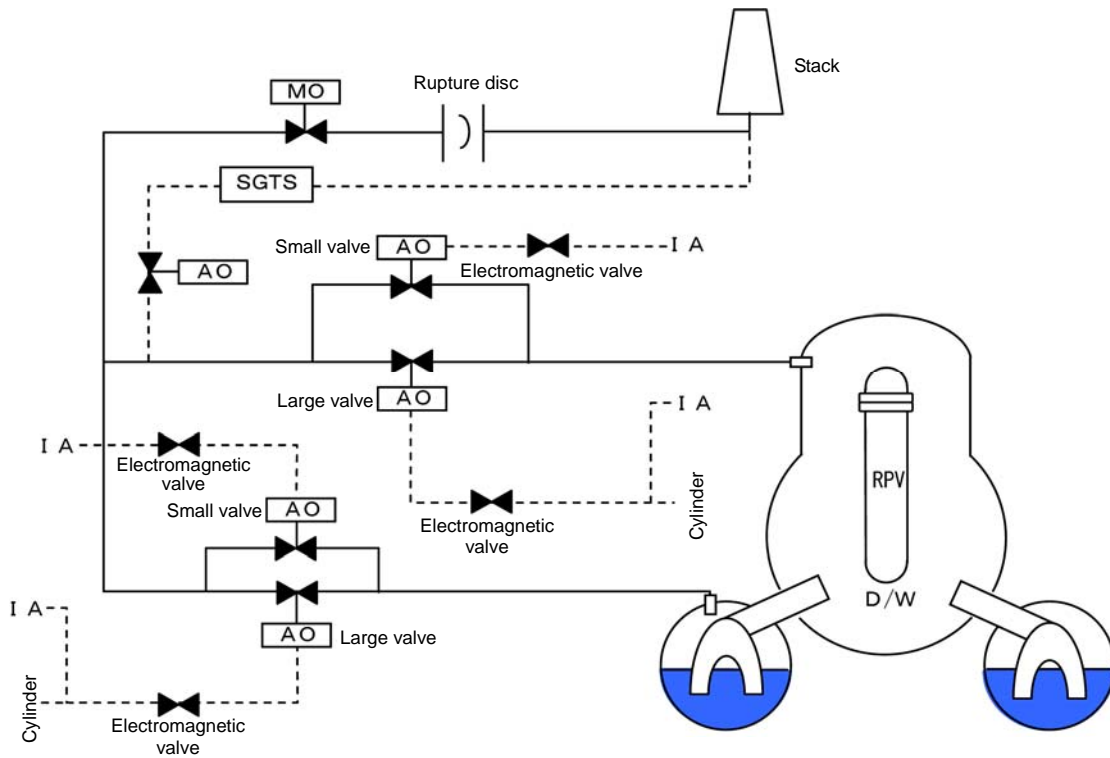

Figure Reference1-6 Pressure resistant reinforced vent system (Unit 1)

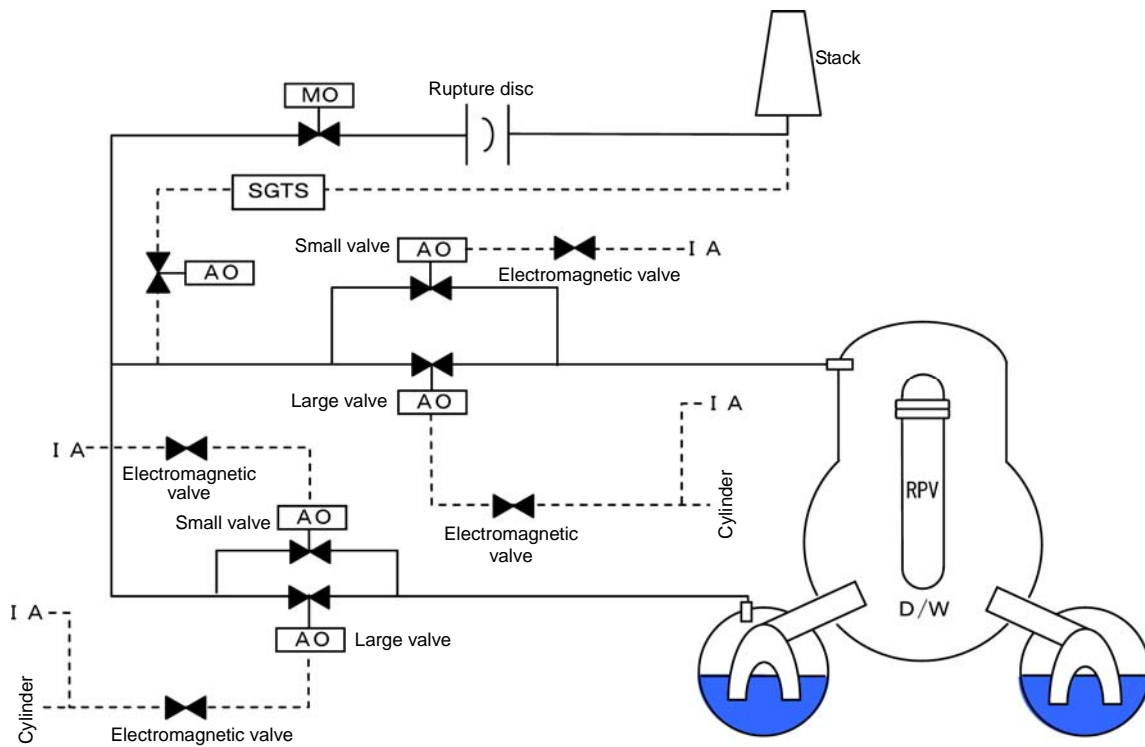
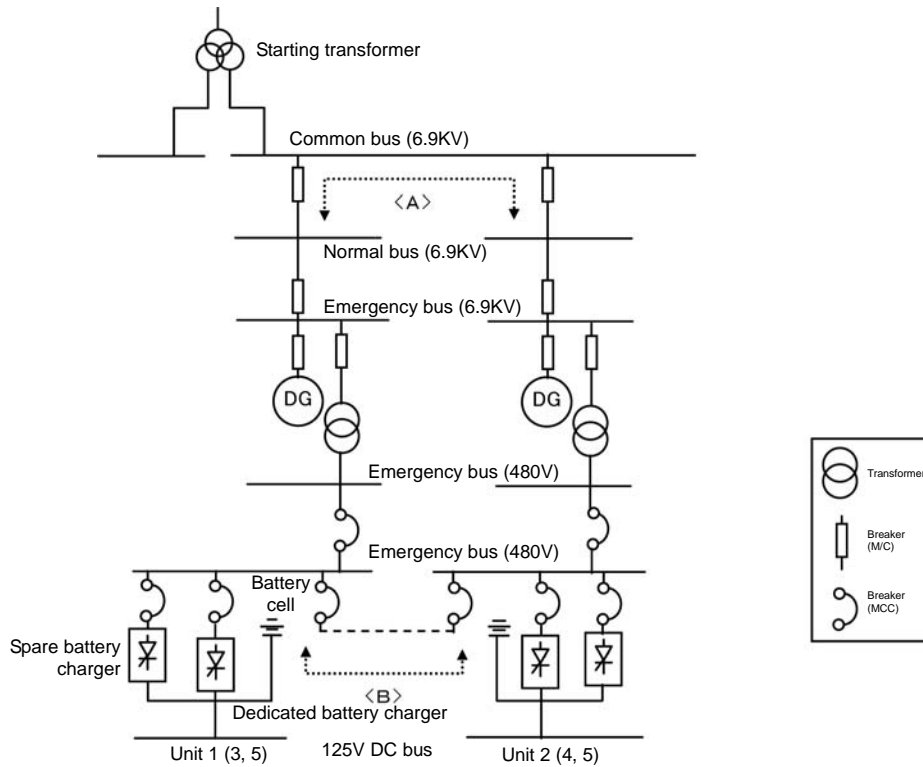

Figure Reference1-7 Pressure resistant reinforced vent system (Units 2 and 3)



- <A> Route: Interchanges 6.9KV AC power supply.
(Operation at M/C is possible only if DC power is available)
- Route: Interchanges 480V AC power supply.
(MCC is manually operated. MCC is normally open and its access is controlled by key lock.)

Figure Reference 1-8 Power supply interchange